

Indian Maritime University
(A Central University, Govt of India)
September/October 2024 – Supplementary Examinations

Programme Name: B Tech (Marine Engineering)

Semester: I

Subject Code: UG11T4102

Subject Name: PHYSICS

Date: 03.09.2024

Max Marks: 70

Duration: 03 Hrs

Pass Marks: 35

General Instructions

- (i) All Sections (A, B & C) are to be attempted.
- (ii) Options, if any, are specified in respective section.

Section A

Ten MCQs/Fill in the Blanks of 01 Mark each – Choose the correct answer as applicable.

1. Faraday's law is valid for
 - (a) Only point charge
 - (b) for both point charge and distributed charge
 - (c) Only distributed charges
 - (d) Neither distributed nor point charge
2. Appliances based on heating effect of electric current work on
 - (a) DC only
 - (b) AC only
 - (c) Both AC & DC
 - (d) None of the above
3. For any medium , electric flux density D is related to electric intensity E by the equation
 - (a) $D = \epsilon_0 E$
 - (b) $D = \epsilon_0 \epsilon_r E$
 - (c) $D = E / \epsilon_0 \epsilon_r$
 - (d) $D = \epsilon_0 E / \epsilon_r$
4. The direction of induced e.m.f can be found by

- (a) Laplace law
 - (b) Lenz law
 - (c) Fleming's right hand rule
 - (d) Kirchhoff's voltage law
5. An electric fan and a heater are marked 100 W, 220 V and 1000 W, 220 V respectively. The resistance of the heater is
- (a) zero
 - (b) greater than that of fan
 - (c) less than that of fan
 - (d) equal to that of fan
6. A free-body diagram is
- (a) It's a sketch of a moving body that shows internal forces of the body and reaction forces
 - (b) It's a sketch of an undisturbed body that shows external forces of the body
 - (c) It's a sketch of an isolated body that shows external forces of the body and reaction forces
 - (d) It's a sketch of a body in motion that shows bending forces of the body
7. According to law of triangle of forces
- (a) Three forces acting at a point will be in equilibrium
 - (b) Three forces acting at a point can be represented by a triangle, each side being proportional to respective force
 - (c) If three forces acting at a point are in equilibrium, each force is proportional to the sine of the angle between the other two
 - (d) If three forces acting upon a particle are represented in magnitude and direction by the sides of a triangle, taken in order, they will be in equilibrium
8. Couple is formed due to two _____
- (a) like, parallel and non-collinear forces of same magnitude
 - (b) like, perpendicular and collinear forces of different magnitude
 - (c) unlike, parallel and non-collinear forces of same magnitude
 - (d) unlike, perpendicular and non-collinear forces of different magnitude
9. The force of friction between two bodies in contact

- (a) Is always normal to the surface of their contact
 - (b) Depends upon the relative velocity between them
 - (c) Depends upon the area of their contact
 - (d) All of the above
10. If a body is in equilibrium. We may conclude that
- (a) No force is acting on the body
 - (b) The resultant of all the forces acting on it is zero
 - (c) The moments of the forces about any point is zero
 - (d) Both (b) and (c)

Section B

Five Questions of 02 Marks each

11. Two forces of 100 N and 150 N are acting simultaneously at a point. What is the resultant of these two forces, if the angle between them is 45° ?
12. What are magnetic field lines? Justify the following statements:
- (i) Two magnetic field lines never intersect each other.
 - (ii) Magnetic fields are closed curves.
13. Write a short note on electron drift velocity
14. State and explain Coulomb's law in electrostatics
15. Explain skin effect. List the factors that affect skin effect.

Section C

Seven Questions of 10 Marks each of which any 05 questions to be answered.

16. a) Define coefficient of friction and angle of friction. Establish relation between them. Also show that angle of friction and angle of repose are equal. (06 marks)
- b) A mass of 4 kg rests on a horizontal plane. The plane is gradually inclined until at an angle $\theta = 15^\circ$ with the horizontal, the mass just begins to slide. What is the coefficient of static friction between the block and the surface? (04 marks)

17. (a) Draw and explain B-H curve of a ferromagnetic material.
 (b) Write the difference between self-inductance & mutual inductance.
 (05 marks + 05 marks)
18. a) State & prove Law of parallelogram of forces (05 marks)
 b) Two forces of 100 N and 150 N are acting simultaneously at a point.
 Find the resultant if the angle between them is 45° (05 marks)
19. a) State and Explain Kirchhoff's Law. (04 marks)
 b) Find the unknown circuit parameters and power delivered by a 10 V battery for the simple parallel circuit shown below: (06 marks)

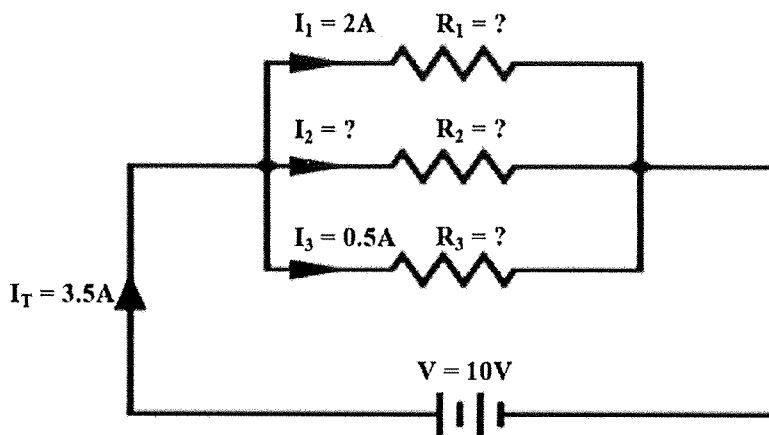

20. a) With necessary waveform explain lead and lag associated with an alternating quantity (05 marks)
 b) An alternating current of frequency 60 Hz has a maximum value of 12 A.
 (i) Write down the equation for instantaneous values.
 (ii) Find the value of the current after $1/360$ seconds.
 (iii) Find the time taken to reach 9.6 A for the first time.
 (05 marks)
21. Derive an expression for electric potential due to a point charge (10 Marks)
22. a) State and prove Lami's theorem (06 marks)
 b) What is Free body diagram? How to draw a free-body diagram?
 (04 marks)