

Indian Maritime University
(A Central University, Govt of India)
End Semester Examinations – June 2023

Programme Name: B Tech (ME)

Semester: IV

Subject Code: UG11T3407

Subject Name: APPLIED MARINE CONTROL AND AUTOMATION

Date: 31.05.2023

Max Marks: 70

Duration: 03 Hrs

Pass Marks: 35

- (i) All Sections (A, B & C) are to be attempted.
(ii) Options, if any, are specified in respective section.

Section A

Ten MCQs/Fill in the Blanks of 01 Mark each – Choose the correct answer as applicable.

1. Negative feedback is widely used in control system since _____
 - a) Accuracy in tracking steady state value
 - b) Rejection of disturbance signal.
 - c) Low sensitivity to parameter variation.
 - d) All the above

2. Actuator is also known as
 - (a) Sensor
 - (b) Final Control Element
 - (c) Transducer
 - (d) Controller

3. Two-step Control is same as
 - (a) On-Off Control
 - (b) PI Control
 - (c) PD Control
 - (d) PID Control

4. Orifice meter is suitable to measure the flow in _____
 - a) Vertical position
 - b) Horizontal position
 - c) Inclined position
 - d) All the above

5. flapper nozzle arrangement is a basic _____

- a) I-P converter
 - b) I-V converter
 - c) V-I converter
 - d) All the above
6. LVDT expands_____
- a) Linear variable differential transformer
 - b) Linear variable diaphragm transformer
 - c) Linear variable differential transducer
 - d) None of the above.
7. Ratio control system is a special type _____
- a) Closed loop control system
 - b) Open loop control system
 - c) Both a and b
 - d) None of the above
8. Thermistor is a negative temperature co-efficient device_____
- a) False
 - b) True
9. A well planned combustion control system will give the _____
- a) Better fuel efficiency.
 - b) Good steam output
 - c) Good feed water control
 - d) All the above
10. Strain gauge is a _____
- a) Pressure sensor
 - b) Temperature sensor
 - c) Actuating device
 - d) Control device.

Section B

Five Questions of 02 Marks each

11. List out the methods used for representation of mathematical modelling.
12. Explain the working of hydraulic servomotor.
13. How to identify the type number of the system with given transfer function.
14. Why the derivative controller is not been used individually in control applications.
15. How does the photo voltaic cell work?

Section C

Seven Questions of 10 Marks each of which any 05 questions to be answered.

16. Explain the oil mist detector for main engine using suitable sketch (10)

17. A) determine the overall transfer function ($C(s)/R(s)$) using mason's gain formula. (5)

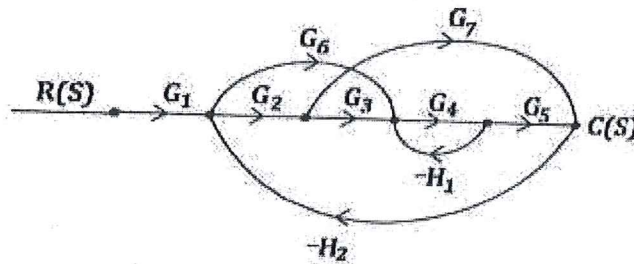

B) Derive the Transfer function of negative feedback closed loop gain having forward gain $G(s)$ and feedback gain $H(s)$ while output is $C(s)$ and input is $R(s)$. (5)

18. A) Define delay time, rise time, peak time related to the second order underdamped system. (3)

B) For the mechanical system shown in figure obtain differential expressions and draw the force-voltage and force-current electrical analogous circuit. (7)

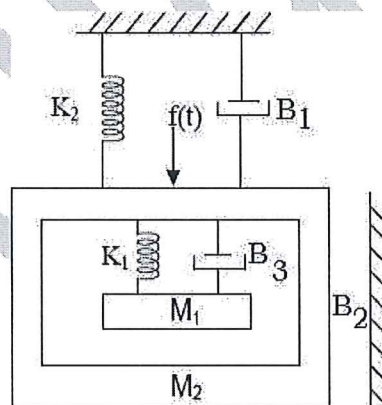

19. Draw and explain the spring and Diaphragm actuators (10)

20. A) Explain the on-off controller with necessary diagram. (5)

B) Write a short note on PID controller (5)

21 A) Explain Single point positioning combustion control system & sketch (5)

B) Draw a simple structure of Pitot tube (5)

22. A) write short note on cascaded controller with relevant sketch. (6)

B) Explain the inherent characteristics of control valve. (4)

