



**Tolani Maritime Institute**

# TRANSTECH'22

24<sup>th</sup> to 26<sup>th</sup> March 2021

Theme

**FUTURE TRENDS IN SHIPPING INDUSTRY**

Sub-Themes

## Blue Economy

Industry 4.0 in Maritime Sector

Alternative Propulsion Systems

New Techniques and  
Advancements in Firefighting

IMO's GHG Strategy:  
How to Meet 2030 and 2050 Goals

Innovative Solutions  
for Ship-Shore Data Link for Real Time Monitoring

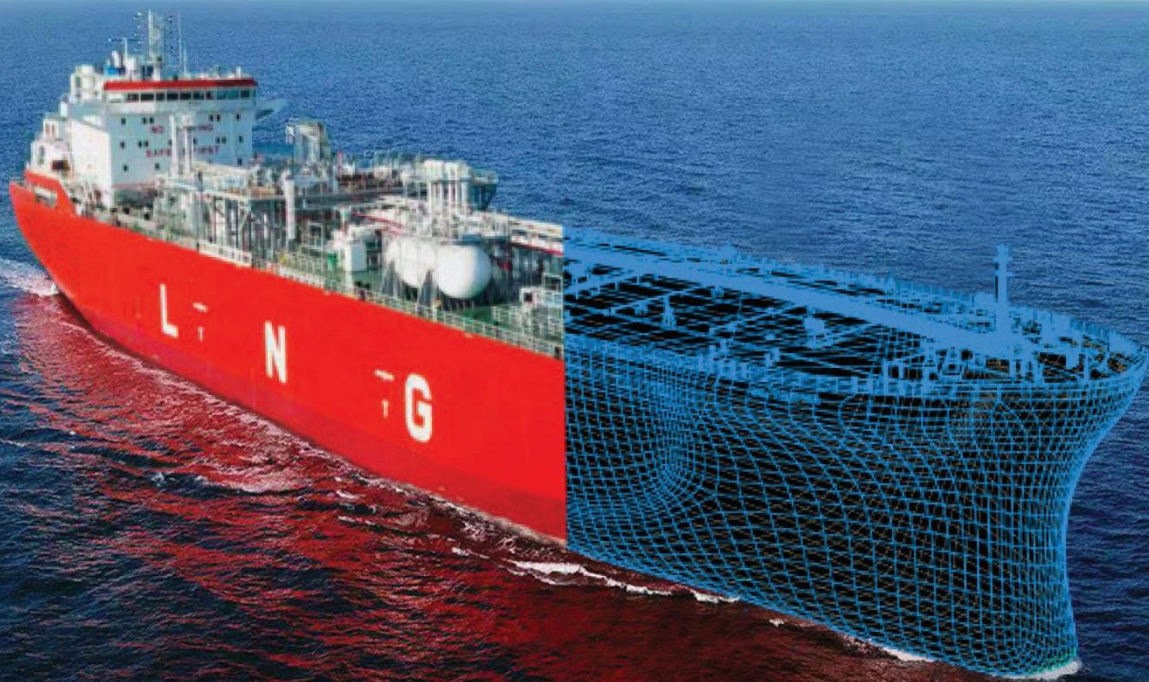
Maritime Education & Training  
Framework for Autonomous Vessel Operations

Technological Advancements in Navigation Communication  
and Search & Rescue in Maritime Industry







# LEADING THE WAY IN SHIP MANAGEMENT SERVICES



Synergy Marine Pte. Ltd.  
1 Kim Seng Promenade  
#10-11/12 Great World City West Tower  
Singapore - 237994

 +65-6278-8233

 [synergymarinegroup.com](http://synergymarinegroup.com)

Singapore | India | Philippines | Hong Kong | USA | Australia  
South Korea | Denmark | Myanmar | China | Dubai | Germany | Japan



#### MESSAGE

The theme of Transtech' 22 is "Future Trends in Shipping Industry". As always, adapting to the times, this year we are going into hybrid mode, hoping to add to the fervour of Transtech. Congratulations to the team who painstakingly continue to make this event possible, for the greater purpose of keeping live our quest of knowledge and continued professional development.

"Change is the only constant"; some constants will need to change while among these changes there could be some constants. Even while Elon Musk intends making human-being multi planetary, we can be sure that sea transport is here to stay.

Evolving maritime education and training will pave the way for smooth transitions to the changing technology and for safer and cleaner seas. Considering the limited crew members and resources on-board, ships will always need to be handled with utmost discipline, a sense of responsibility and uncompromised competency. Knowledge sharing by the young minds along with the experienced, in forums like this will bridge the gap created by the ever-changing and evolving technologies.

Congratulations to all those who submitted papers to this competition and as always a special thanks to our guest speakers who contribute invaluablely to the success of our seminar.

**Dr. Sujata Naik**  
Chairperson  
Governing Council  
Tolani Maritime Institute, Pune



## MESSAGE

I feel delighted that Tolani Maritime Institute is again organizing TRANSTECH, which has provided a platform to the professionals of tomorrow, from Maritime Training Institutes and other Engineering Colleges to showcase their talent and churn out new ideas for the future of the maritime sector. Transtech '22 will be conducted in hybrid mode for ease of the participants keeping the spirit of TRANSTECH high. We are organizing TRANSTECH since 2007, this will be our 15<sup>th</sup> Year of celebration of excellence.

The industrial revolutions have transformed our technological milieu. The fourth industrial revolution has blurred the boundaries between the physical, digital, and biological worlds. It is a fusion of advances in all technological fields. Unlike the previous three revolutions, Shipping is an integral part of the fourth industrial revolution. Thus the theme of Transtech '22, "Future Trends in the Shipping Industry" is expected to address the needs of the industry and enable Institutes to act upon them.

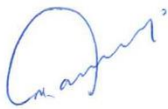
Transtech, over the last decade, has dealt with innovative topics and brought many students from different academic institutions across the country to come together and share their ideas. These ideas have evolved in technical paper presentations, demonstrating models and interaction with experts from the industry.

The rock-steady support from the two prestigious professional bodies, namely The Institution of Engineers (India), Pune Local Centre and The Institute of Marine Engineers (India) Pune Branch, is praiseworthy and multiplies the importance of the event.

I am sure Transtech '22 will allow our cadets and teachers to interact with the speakers from the industry and students from various colleges online.

I take this opportunity to extend my best wishes to Prof Anirudh Kumar and his organizing team for successfully organizing Transtech '22.

Let us come together, think together and grow together!



**Dr. Sanjeet Kanungo**  
Principal

# The Institution of Engineers (India)

(Established: 1920 - Incorporated by Royal Charter:1935)

*"A Century of service to the Nation"*

## **PUNE LOCAL CENTRE**

ABHIYANTA BHAVAN 1332, Shivajinagar, JM Road, PUNE - 411 005.

**Dr. S. B. Zope, FIE**  
*Chairman*  
**Er. Vipin Munot, AMIE**  
*Honorary Secretary*



Phones : 020-25533376, 25520239  
Facsimile : 020-25530150  
E-mail : [punelc@ieindia.org](mailto:punelc@ieindia.org)  
Web-site : [www.ieipune.org](http://www.ieipune.org)

### **IEI-PLC Chairman's Message**

It is a matter of immense pleasure to note that Tolani Maritime Institute, Induri in association with The Institution of Engineers (India), Pune Local Centre and The Institute of Marine Engineers (India), Pune Branch is organizing Annual Seminar for Students "TRANSTECH-22" on the theme "Future Trends in Shipping Industry" during March24-26, 2022. Shipping is a vital cogwheel in the world's trade machine. Ships offer the best option, when it comes down to transporting material around the planet, particularly bulk transport of ore, coal, oil and cereals for which there is no alternative. Shipping already has been experiencing the application of new technology by adapting Industry 4.0 revolution. Digitisation is no exception in the world shipping. Automation, Artificial Intelligence (AI), Machine Learning (ML), use of robots and unmanned systems in the operations are the immediate future in shipping world. As a result, people are getting tuned to the concept of technology driven, environmentally friendly, challenging and Cleanecosystem-based shipping.

I am confident that the during the seminar numerous emerging technologies will be discussed which will be helpful in creating tangible understanding so as to achieve Efficient and Effective Shipping. I wish the Seminar a grand success and extend my greetings to all concerned.

With Best Wishes

**Dr. Sanjay Zope**  
Chairman IEI-PLC  
Date: 19/03/2022

# The Institute of Marine Engineers (India)



1012, MAKER CHAMBERS-V, NARIMAN POINT, MUMBAI - 400 021. TELEFAX : 2834035 ● TEL. : 2840105.



Shri Sanjeev. D. Ogale  
Chairman  
Pune Branch  
Tel: 020- 24269783  
Email-chairmanpune@imare.in

It is indeed a matter of great pride that Tolani Maritime Institute in association with The Institute of Marine Engineers (India) Pune Branch and The Institution of Engineers (India), Pune Local Centre are hosting “Transtech 2022” as a part of its Annual Event.

Transtech 2022 now elevating to an International Conference/Seminar will provide a common platform for Engineering students in all fields to present technical papers on various topics of interest, encouraging the students to do research work and empowering them with thinking ability. This will help the students to exchange ideas, and latest technical developments in various disciplines.

I am confident the theme “Future Trends in Shipping Industry” will give the students the right direction in his or her pursuit of greater understanding of the subject.

I wish the seminar a grand success and my greetings and compliments to all the organizing team.

Sanjeev Ogale  
Chairman  
The Institute of Marine Engineers (India)  
Pune Branch

#### **Pune Branch Address**

Institute of Marine Engineers (India), Pune Branch  
PLOT NO. 34, POONA SMALL SCALE INDUSTRIAL ESTATE, GULTEKDI, PUNE – 411 037.  
**Tel.: 91-20-2426 1679, 2426 9783**

Tolani Maritime Institute, Pune,  
in association with  
The Institute of Marine Engineers, Pune Branch and  
The Institution of Engineers, Pune Local Centre

proudly presents All India Seminar

**TRANSTECH 2022**  
**on**  
**"Future Trends in Shipping Industry"**

from

24 to 26 March 2022

in  
hybrid mode

**YouTube links for watching online:**

1st day: <https://youtu.be/yjFtKkQj86Q>

2nd day: <https://youtu.be/rVPvzWmnhms>

3rd day: <https://youtu.be/jSR17DSsy98>

## PROGRAMME SCHEDULE

**Day 1, Thursday, 24th March 2022**

| <b>Time</b> | <b>Activities</b>  |
|-------------|--|
| 0900-1000   | Registration and Refreshment   |
| 1000-1215   | Inauguration   |
| 1000        | Chief Guest, <b>Capt M. Sairaj</b> , Director, Synergy Navis Marine Pte Ltd arrives  |
| 1000-1003   | Lighting of the lamp   |
| 1003-1007   | Saraswati Vandana  |
| 1007-1010   | Floral welcome of the Chief Guest and the Guest Speaker  |
| 1010-1015   | Welcome address by <b>Principal</b> , TMI  |
| 1015-1025   | TMI Corporate Video  |
| 1025-1030   | Introduction of Transtech by <b>Mr. Anirudh Kumar</b> , Convener, Transtech '22  |
| 1030-1040   | Video on Transtech '22   |
| 1040-1045   | Address by <b>Mr. Sanjeev Ogale</b> , Chairman, Institute of Marine Engineers (I), Pune Branch   |
| 1045-1050   | Address by <b>Dr. Sanjay B. Zope</b> , Chairman, The Institution of Engineers (India), Pune Local Centre   |
| 1050-1135   | (a) Introduction of Guest Speaker, <b>Mr. Chirag Bahri</b> , Director of Regions at International Seafarers' Welfare & Assistance Network (ISWAN)<br>(b) Talk by Mr. Chirag Bahri on "Pre-departure Awareness for Seafarers" |
| 1135-1145   | (a) Introduction of the Chief Guest<br>(b) Release of ' <i>Transtech-2022 Proceedings</i> ' & ' <i>TMI Technical Bulletin</i> ' by the Chief Guest   |
| 1145-1210   | Inaugural Speech by the Chief Guest on "The innovative smart ship solutions".  |
| 1210-1215   | Vote of Thanks   |
| 1230-1330   | Lunch break  |
| 1340-1350   | Introduction of Judges   |
| 1350-1510   | <b>Technical Session I - (4 papers)</b>  |
| 1510-1525   | Tea break  |
| 1525-1645   | <b>Technical Session II - (4 papers)</b>   |

## Day 2, Friday, 25th March 2022

| Time      | Activities   |
|-----------|--|
| 0930-0950 | Registration and Refreshment   |
| 0950      | Guest Speakers arrive  |
| 0950-0955 | Floral Welcome of the Guest Speakers   |
| 0955-1005 | TMI Corporate Video  |
| 1005-1010 | Welcome address by Principal, TMI  |
| 1010-1020 | Video on Transtech '22   |
| 1020-1100 | (a) Introduction of Guest Speaker <b>Mr. Praful Kalankar</b> , Director, S P Auto Engineering<br>(b) Technical talk by Guest Speaker on "Total Quality Management"   |
| 1100-1140 | (a) Introduction of Guest Speakers " <b>Prof. Tanuja Sachin Khatavkar</b> , Regional Coordinator (Pune), Virtual Labs Regional Centre, IIT Bombay" and " <b>Prof. Pushdeep Mishra</b> , Senior Project Manager, Virtual Labs- IIT Bombay"<br>(b) Technical talk by Guest Speakers on "Introduction to Virtual labs." |
| 1140-1145 | Vote of Thanks   |
| 1145-1305 | <b>Technical Session III - (4 papers)</b>  |
| 1305-1400 | Lunch break  |
| 1405-1530 | <b>Marine Quiz Competition</b>   |
| 1530-1540 | Tea break  |
| 1540-1610 | <b>Posters Display</b>   |
| 1610-1725 | <b>Online Exhibition of Models</b>   |

**Day 3, Saturday, 26th March 2022**

| <b>Time</b> | <b>Activities</b>  |
|-------------|--|
| 0930-1000   | Registration and Refreshment   |
| 1000        | Chief Guest <b>Dr.(Mrs.) Malini V Shankar</b> , IAS (Retd), Vice Chancellor, Indian Maritime University arrives  |
| 1000-1020   | Inauguration of Simulators by the Chief Guest  |
| 1020-1025   | Floral welcome of the Chief Guest and the Guest Speaker  |
| 1025-1035   | TMI Corporate Video  |
| 1035-1040   | Welcome Speech by Principal, TMI   |
| 1040-1050   | Video on Transtech '22   |
| 1050-1135   | (a) Introduction of Guest Speaker <b>Capt. Nikunj Parashar</b> , CEO & Director, Sagar Defence<br>(b) Technical talk by the Guest Speaker on “Remote Operation of Vessels” |
| 1135-1220   | (a) Introduction of the Chief Guest<br>(b) Talk by the Chief Guest on “Challenges in Maritime Education and Training to Deal with Future Trends in Shipping”               |
| 1220-1305   | Valedictory Function<br>1220 Conference Summary<br>1225 Address by Judges<br>1235 Memento presentation to Judges<br>1240 Prize Distribution by Chief Guest                 |
| 1305-1310   | Address by <b>Dr. Sujata Naik</b> , Chairperson, Governing Council, TMI  |
| 1310-1315   | Vote of Thanks   |
| 1315        | Lunch  |

# INDEX

## Papers

01. Blue economy: challenges faced and its future scope in marine fisheries, seaports, and shipping in India 1
02. Industry 4.0, shipping and psychological well-being at sea 10
03. Stress monitoring system (SMS) 18
04. Fuel cell as an alternate propulsion system 25
05. Alternative propulsion system 28
06. Hybrid energy regenerating system 38
07. Eco friendly shipping through nanotechnology 45
08. Smart fire extinguishing device (SFED) 51
09. Black Carbon as a Form of Green House Gas 58
10. Technological advancement in navigation, communication and search & rescue in maritime industry 65
11. IMO's GHG strategy: how to meet 2030 and 2050 78
12. Review analysis on advancements in NCSR technologies 83

## Models

01. Portable Rescue Boat 92
  02. Fire Fighting Robot with Gas Detection System 97
  03. Safety And Efficiency Improving Technologies in Autonomous Ships 104
  04. Ideal Model Ships (IMS) 111
  05. Green Energy Power Generation on Ship Using VAWT 117
  06. Thermoelectric Cooler- Waste Heat Recovery System on Ships 123
  07. A Zipod Propulsion with Air Lubrication System 126
-

# **BLUE ECONOMY: CHALLENGES FACED AND ITS FUTURE SCOPE IN MARINE FISHERIES, SEAPORTS, AND SHIPPING IN INDIA**

Cdt Linto Varghese<sup>a</sup>, Cdt Altamash, Faruk Tamboli<sup>b</sup>, and  
Cdt Mohammad Armaan Mansoor<sup>c</sup>

<sup>a</sup>The Great Eastern Institute Of Maritime Studies, Lonavala,  
lintovarg@gmail.com, 7907010428

<sup>b</sup>The Great Eastern Institute Of Maritime Studies, Lonavala,  
atamboli07@gmail.com, 9920909803

<sup>c</sup>The Great Eastern Institute Of Maritime Studies, Lonavala,  
armaanmansoor1999@gmail.com, 9548073770

## **Abstract:**

Typically, the blue economy can be a subject that relates to sustainable use regarding ocean resources intended for economic growth and even development, as effectively as preservation regarding the health of the ocean ecosystem, which includes becoming a vital aspect of typically the broader ecosystem intended for better development. The desire to sustainably increase the potential regarding the ocean and underwater resources has recently been obvious on the countrywide and international degrees. This paper extremely focuses on the latest scenario and future improvements in fisheries as well as seaports and shipping inside India that can be reached through Blue Economy.

## **1. Introduction:**

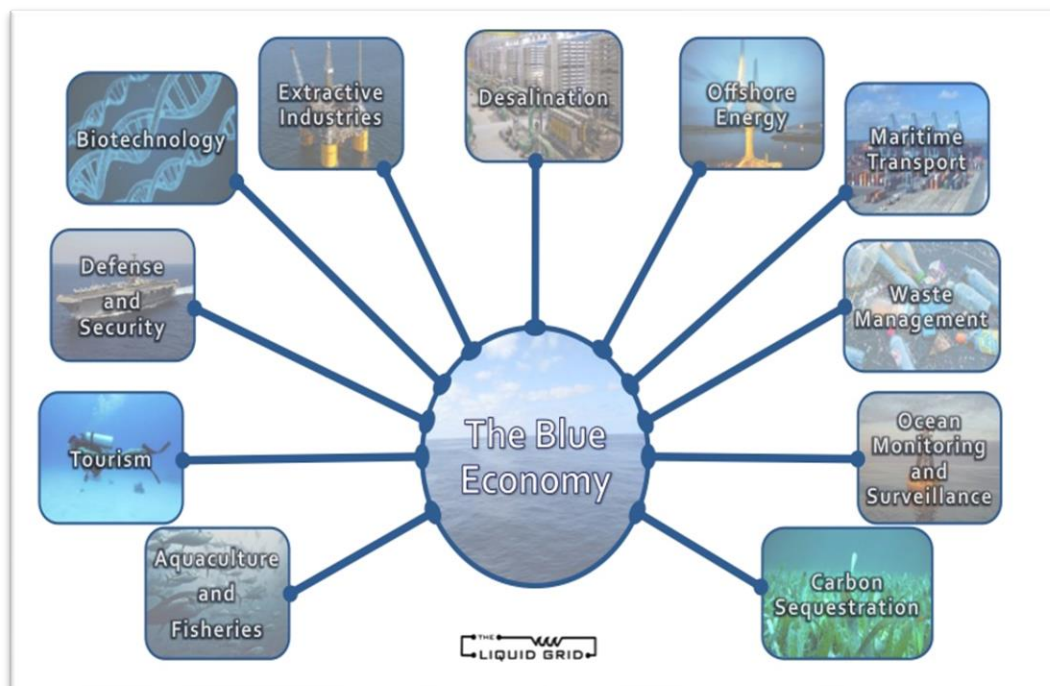
### **What Is A Blue Economy?**

Based on World Bank, the blue economy is the "sustainable use of ocean resources helpful for the economical process, improved livelihoods, and jobs whereas saving the health of the ocean system." Teacher member Gunter Pauli at the UN University (UNU) to mirror the requirements of future progress and prosperity, besides the threats uncover by warming introduced the economic philosophy of the Blue Economy in 1994. The particular thought relies on developing additional proper development models, as well as ideas of engineering reinforced "no waste and no emissions".

Typically, the Blue Economy includes all industries and sectors linked to the ocean, the sea, plus the shoreline, as well as the marine atmosphere (e. g., shipping, and delivery, fisheries, power generation) or in the direction of land (e. g., plug-ins, construction, upcountry fostering). Coastal business is a massive and rapidly growing sector of the economy and has taken important steps towards modernization and diversification over the past decade. In addition to ancient sectors, modern sectors like underwater renewable energy, the blue bio-economy, biotechnology, and chemical process square measure creating and developing, difference up to new prospects and making jobs. The blue economy is moreover attached to cultivation through a distinct network of activities. The blue economy is also linked to agriculture through a separate network of activities and supply chains. According to the latest figures from the Blue Economy Report 2020, in 2018 the EU blue economy employed about 4.5 million people, generated sales of about 650 billion euros, and a total value added of 176 billion euros towards a sustainable blue economy. By way of a proper blue economy, maritime and coastal activities

combine economic development, superior living standards, and social cohesion with addressing climate change, preserving diversity and ecosystems, victimization resources responsibly, and reaching zero pollution goals.

The sea and its importance for proper development cannot be denied. Oceans cover more than two-thirds of the Earth's surface, help reduce poverty by providing sustainable livelihoods and decent work, provide food and minerals, produce oxygen, absorb greenhouse gases, and reduce the effects of climate change by determining weather and temperature patterns. In addition, it serves as a highway for international maritime trade. Since roughly eighty percent of world trade is accomplished by the ocean, international shipping, delivery, and ports play a vital link to maintaining a healthy supply chain and provide all countries an opportunity to access the global market.



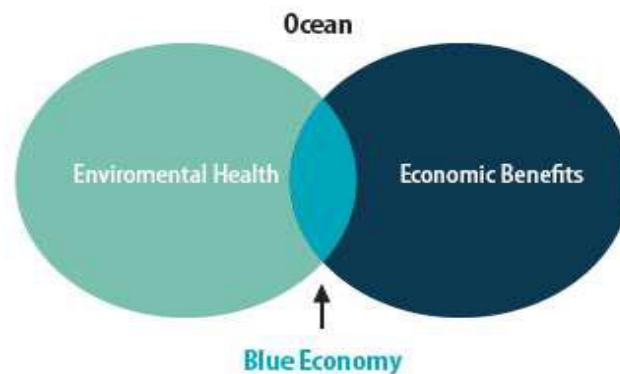
**Fig. 01:** *Components in Blue Economy*

### 1.1 Principles of Sustainable Blue Economy

You cannot find any universally accepted meaning of the blue financial system. However, several organizations want to elucidate a way to perceive this idea. Different areas, governments, and organizations use different rules and descriptions. A great associate example is the principles set out by WWF. A suitable BLUE ECONOMY is a marine-based economy that.

- Provides sociable and economical ends for current and future generations by contributing to food security, reduction of poverty, livelihoods, income, employment, health, protection, equity, and politics.
- Restores and looks after the variety, productivity, strength, core functions, and intrinsic price of marine ecosystems—the natural capital on that its prosperity will depend.

- It relies on clean technologies, green energy, and spherical material flows to generate economical and sociable stability over time while keeping inside the boundaries of one planet.



**Fig. 02:** *Definition of Blue Economy*

## 1.2 Need for Blue Economy

- Seas cover three-fourths of the Earth's surface; it consists 97% of the Earth's water and represent 99% associated with the living region on the world.
- Our oceans safeguard our planet's biodiversity, maintain our earth awesomely, and absorb earth's 30% CARBON DIOXIDE emission.
- A minimum of 3-5% of global GROSS DOMESTIC PRODUCT comes from the oceans.
- With the lasting utilization of the sea, the blue economy has the enormous possibility to stimulate financial growth by offering opportunities in income generation plus job creation. Assistance to food security and even diversification to uncover fresh energy sources, fresh medicines, valuable substances, protein foods, serious minerals, safety, and even more.

## 2. Main Work:

### 2.1 Blue Economy and India

Indian features a distinctive maritime position. Their 7517-kilometer-long description hosts 9 seaside states and 1382 islands. The country has 12 major ports and 187 non-major ports, managing 1400 million tonnes of shipments each annum, as 95% of India's business by volume is channelled by the marine industry. India's Exclusive Economic Zone of over 2 million sq. kilometres is constructed of dwelling and non-living resources and holds important renewable resources of petroleum and gas. The seaside economy conjointly maintains over 4,000,000 anglers and various coastal communities. Using these large maritime pursuits, the Blue Economy in Asian nations around the world, features an important relationship with the nation's economic process. Lately, there are a series of initiatives for proper development within the maritime domain. These types of initiatives are factors to exercise the development of India's ocean-going interests and our Blue Economy within the post COVID-19 international situation, the Asian country is probably going to witness important progress within the ocean sector by cost-effective and proper usage of ocean resources.

Keeping these aspects in mind, India's Blue Economy is outlined as a collection of the economic system comprising of the whole system of ocean resources and semisynthetic economical facilities in marine, ocean-going, and onshore seaside zones inside India's legal jurisdiction. This aids within the production of products and services and have clear cordons with the economical process, environmental property, and national security.

In the Indian native context, the Glowing blue Economy policy has to accept several aspects. For instance, it should embody all aspects of offshore sovereignty. It should convey economically valuable resources in water, likewise, as on and beneath the seabed, onshore infrastructures like seaports, maritime paths attached with household and international industry, and offshore energy resources, be they fossil-based or alternative. It should look at the setup of products and services from the fishing industry, marine producing, delivery, and tourism that is attached to the ocean and the seas. Other equally significant aspects that require inclusion in this policy are ocean governance, maritime security, sustainability concerns, and adherence to international treaties and commitments.

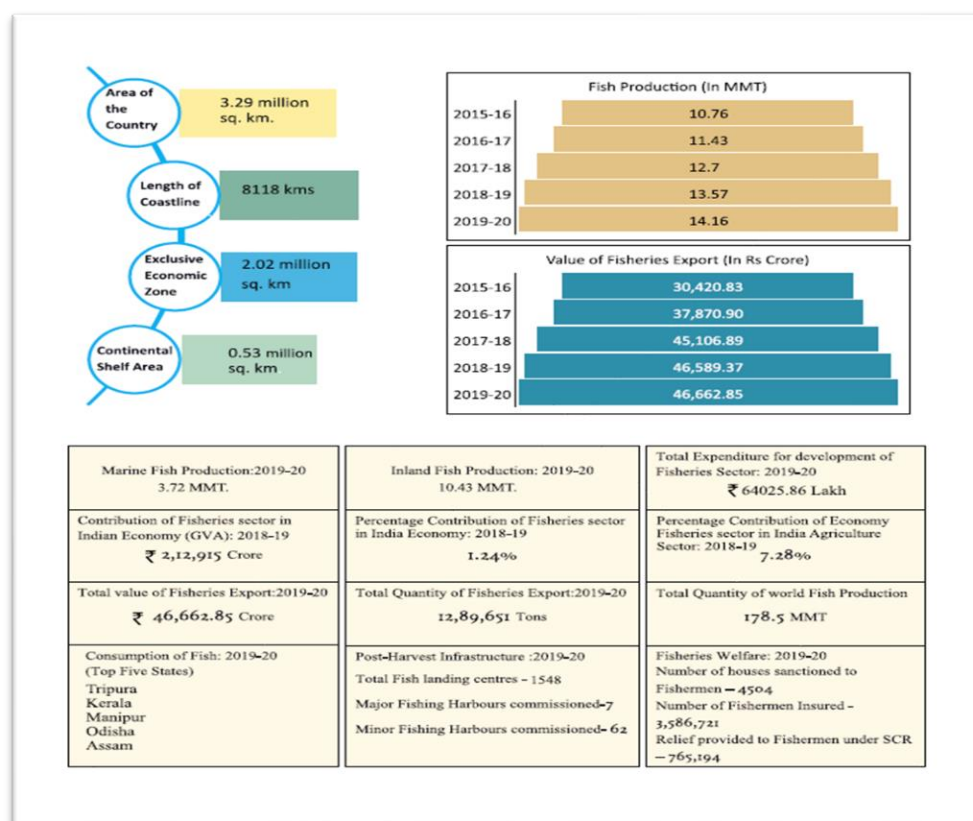
## **2.2 Current Scenario**

### **i) Marine Fisheries, Aquaculture, and Fish Processing Sector**

The fishing industry, which may be an important oceanic resource from the core of the Blue Economy, is one of the most important resources of the Indian ocean which offers food to a lot of numerous folks and greatly contribute to the livelihoods of coastal communities. This plays an important role in making certain food security, poorness alleviation and encompasses a huge possibility for online business offerings. Presently there has been a robust embrace of seafood production from 861,000 tonnes in 1950 to a huge rise of 14.16 million metric tonnes throughout 2019-20. The world's total demand for fish and the fishing industry merchandise is expected to double by 2050, with aquaculture activities foretold to cover 73% of this increase. Cultivation, which offers large potential for the provision of food and livelihoods, can benefit through the Blue Economy including the worth of the natural funds in the development, respecting ecological guidelines throughout production, making proper, tight work, and providing high-value commodities for foreign trade.

To meet the increasing public demand for food merchandise, the fishing industry resources are over-exploited. Consequently, the imperative has to realize a balance between population and environmental health. It has provided the impetus to the promotion of proper fishing and farming. Well-managed fisheries will deliver billion loads of fish every 12 months, whereas cultivation has the potential for continuing strong development to provide the food necessities of a growing world.

Development of the Fisheries and farming sector through higher facilitation and support for trade and transportation can bring about the uplift of trained employee families and can bring about the socio-economic development of the location. This can furthermore facilitate poorness relief. Introducing, social capitalism can benefit the fishing communities largely. Social capitalism is basically reserving a share of profit earned after investing in the ocean resources for the benefits of employees, generating employments, improving livelihoods and preserving the nature All of the above points, prove to play a pivotal role if implemented through the concept of a Blue Economy in India



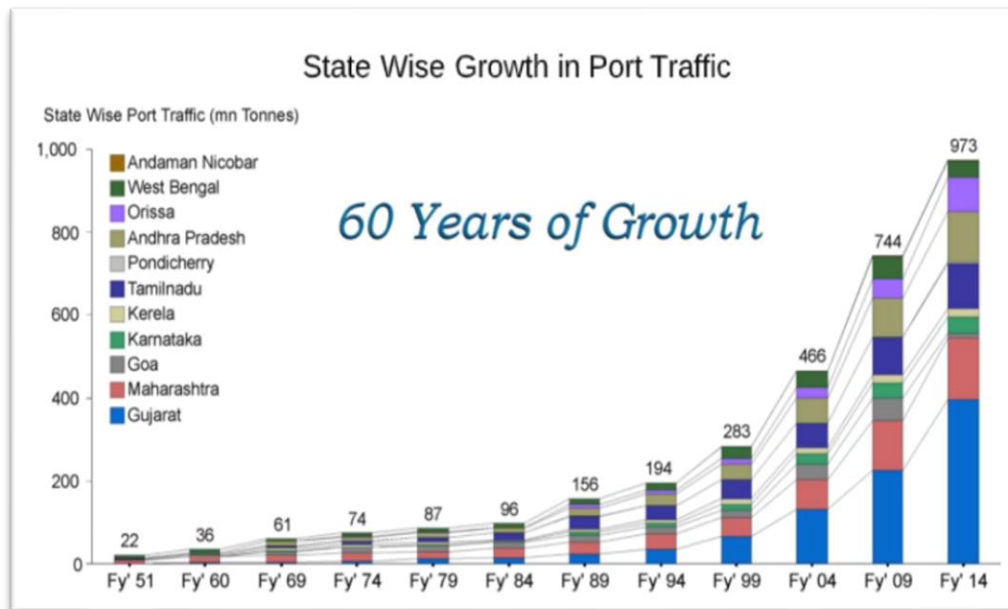
**Fig. 03: Fisheries statistics from 2019-20**

## ii) Seaports & Shipping

The particular harbour and ocean-going transport sectors are among the necessary priority sectors underneath the Blue Economy, within which the Member States are showing a larger interest. Despite the constant rise of ocean-going transport and delivery transactions within the location, uneven distribution of trade exists in one of the rim countries, wherever solely one or two are reaping helpful benefits economically from ocean-going exchanges and transport. Some member states are stressed to stay speed with the quick development and complexity of the maritime industry as they face challenges in phrases of congestion, new data technology, instrumentality, improvement of slot infrastructure, and skilled services. In this regard, regional assistance is very important for unlocking the bottlenecks to slots development and ocean-going economy growth within the ocean to reinforce blue development through economic assistance and trade relationships between the Associate States.

India, once, was among the main economy within the entire world until the first nineteenth hundred years. However, later the downfall started and until the past due twentieth century, the Asian nation observed a huge burden of fund deficit and international debt. In 1991, opted for globalization, liberalization and opened up its economy for foreign trades and since then Asian countries had done considerably well; even throughout our planet's economic recession of 1997 & 2008. India's economy has gone up and therefore the key attribute obtained to the service sector and very less to the producing and different field. During this one sector was neglected which was maritime development. India stocks the coastal boundary with six nations, sanctioning ample chance to harness seawater resources for its economical process through ocean development, developing export-import industry, exploration of natural minerals and energy resources to meet the domestic desires and trade furthermore. India has done very well on the socioeconomic front additionally by making a lot of jobs, impoverishment alleviation

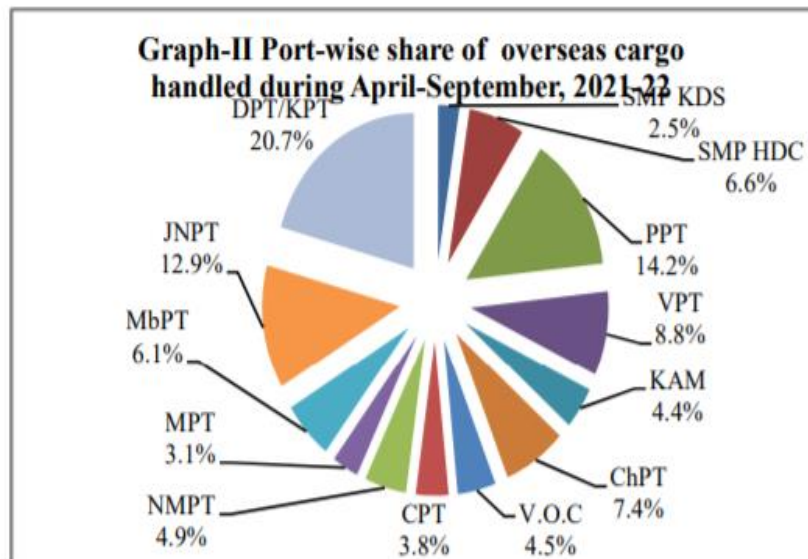
through the strongly preserving ocean development. A good example is Gujarat's condition, which, after building ports as well as facilities witnessed huge development of GDP against predevelopment, which was practically at 5 percent in 1980. Shipping and the nation's economy go hand in hand for the development of GDP. Investing in terms of not only money but also resources is an important factor of development.



**Fig. 04:** Port Growth statistics in India, 2019

Ocean-going Transport may be an essential facility for the interpersonal and economic development of a country. It influences the pace, structure, and pattern of development. Maritime transport activity is driven by developments within the entire world economy, viz, development in world results and results therefore, the level of mobile payload traffic handled by slots is principally created by the level and within each world and household activity. Payload traffic at India's 14 major ports through April-September, 2021-22, filled with air by 15.6% to 346.87 million tonnes from 299.94 million tonnes payload taken care of throughout April-September, 2020-21. The Overseas payload handled at key ports inflated by 15.1% from 231.93 million tonnes throughout April-September, 2020-21 to 267.03 Million tonnes handled in April-September, 2021-22. The Seaside payload handled at Major port also inflated by 17.4% from 68.01 million tonnes throughout April-September, 2020-21 to 79.84 million tonnes taken care of throughout April-September, 2021-22. Blue Economy has to vie an important role in the improvement of these figures. In addition, the development within the rendering of the Blue Economic system will offer dramatic growth in this sector.

Among all the transport modes, inland waterways are the cheapest, environment-friendly, it can supplement rail and road transport, helps in the decongestion of roads, is best suited to carry over-dimensional cargo (ODC), requires minimum land acquisition, and has low infrastructure costs. Yet, despite the runaway benefits, IWT constitutes less than 1% of the total inland cargo movement in the country. The amount of goods transported by IWT in other countries are still modest when compared with other modes of inland transport, such as rail and road, but the percentage is significantly higher.



**Fig. 05:** Cargo Growth statistics in India, 2021-22

## 2.3 Future Scope

### i) Marine Fisheries, Aquaculture, And Fish Processing Sector

- Form a new implementing agency.
- Develop a comprehensive National Mari-culture policy.
- Develop and commercialize Mari-culture, including brood banks, center breeding centers, hatcheries and nurseries, and feed supply through approaches such as sea cage gardening for finfish, bivalve farming, sea-weed gardening, and encouraging sea ornamental fisheries.
- Avoid aquatic diseases that health management facilities by technological backstopping.
- Promote R&D for long-term sustainable development Mari-culture.
- Inclusion of social capitalism for the benefits of fishing communities.

### ii) Seaports & Shipping

- Business of an Ocean-going Development Fund with fund mobilization from stakeholders in Public-Private Partnership ventures.
- Embrace the idea of the hub, talked for the entrance, and feed foreign trade products.
- Build storage, freight aggregation, and cargo loan consolidated infrastructure for the efficient catchment.
- Put into action a cheap nationwide multimodal network built-in on a digital grid to reduce logistics and vehicles costs.
- Develop multi-modal logistics parks and create value-added services (packaging, tagging, crating) in an individual location.
- To fight piracy, developing our coast guards or introducing some agency which can dedicatedly work on the issues of corruption, crime done on oceans and seas and fight piracy.
- Introducing tourism through our inland waterways, which can boost the economy and benefit our motto of utilizing blue economy in developing GDP.

### iii) Overall Constraints and Challenges Faced

- Typically, the ocean and different widespread fishing areas of our country confront bound issues in doing common business. As an example, overfishing/unsustainable sport fishing practices can destroy resources thus removing resource opportunities for communities of such specific sites.
- Likewise, the issues that a proper economy would include the instant experiencing, are pollution, damage of surroundings and bio-diversity, pirates, criminal offenses, and climate change- except the extensive political science problems in step with IPCC's (Intergovernmental Screen on Climate Change), report on global climate change, "India is that the thirteenth most susceptible country to weather change" (Down To Earth, 2015). Dakshina Kannada and Udupi districts of the province have a reportable twenty-eight percent of their shorelines worn thanks to low-lying rise.
- In another instance, state coastal areas have seen a discount of fish capture. Extra water degree rise of just one colour, which may be seeming impact of worldwide weather change, would shift 7.1 million individuals in India, which may be an essential problem that has to tend attention to have proper financial process and development within the fisheries sector.
- Sewage pollution remains a serious issue for India, particularly in coastal areas, producing 4067 million litres of pollution a day, 80% carried into the ocean (Down To Earth, 2014) and thereby killing the fish and various marine products and so reducing the market potential. The problems relating to anglers within the international waterlines, especially with the neighbouring nations are also acting as a rational purpose towards the fishing field.
- Strengthening MSME for taking on the additional business assignment in the coastal region is once again a constraint for the government
- For work – publically: non-public – Collaboration wants an alternative approach for increasing the outcome from blue resources.
- The absence of entombing connection between the public and private prayer within the marine field is nonetheless to attain the landmark.
- Anti-social and anti-commerce activities in sea space, sea piracy, etc have surfaced as nice difficulties to the big event of the blue region.
- Besides these, natural calamities like cyclones, tsunamis, etc furthermore movement a great problem for the growth of the glowing blue economy

Similar to several countries, India is way from achieving excellent governance, and blue growth might generate or exacerbate pre-existing injustices social injustices:

- 1) Dispossession, displacement, and ocean grabbing
- 2) Environmental justice considerations from pollution and waste
- 3) Environmental degradation and reduction of scheme services
- 4) Resource influences for small-scale fishers
- 5) Lost access to marine resources required for food security and eudemonia
- 6) Unjust distribution of economic edges

## 7) Social and cultural impacts

### **Conclusion:**

- The global cooperation and implementation of sea projects such as Sagarmala, Multi-Modal Strategies Parks in India are evidence of the need to develop the Blue Economy. The vision of India can be achieved if a well-planned framework is implemented. The impact on GROSS DOMESTIC PRODUCT can be noticeable by improvement in the lives of coastal communities, conserving our marine biodiversity, and maintaining the safety of our seas, rivers, and ocean resources. Blue Economy will convincingly provide a substantial aspect of growth and employment of our country.
- It displays that India has great potential in the ocean economy. Therefore, to concentrate on the glowing blue economy development, India can integrate the introduction of the portion and can have more lasting business solutions because of its overall economic, interpersonal, and socio-economic development

### **Acknowledgments:**

Thanks to our Principal, Capt. A. P. Sethi, Vice Principal Capt. Philip John, our course in charge, Mr.Narendra Katdare, Mr. Satish Chandra Upadyay, Mr. Milind Kulkarni, Mr. Sudhanshu Phalke, IT instructor, and all Faculty, in investing their valuable time in the compilation of this paper.

Thanks to Mrs. Meena Ravi Shankar, soft skills trainer, for the continuous support and assistance given while preparing our paper.

We are equally grateful to ‘TRANSTECH 2022’, to have given us this opportunity to present our technical ideas on our chosen topic, effectively & efficiently.

### **References:**

1. Nathan J. Bennett, Jessica Blythe, Carole White & Cecilia Campero; Blue Growth and Blue Justice; Year: 2020  
[https://fisheries.sites.olt.ubc.ca/files/2020/06/Take2-2020-02-WP\\_Blue-Growth-and-Blue-Justice-IOF-Working-Paper.pdf](https://fisheries.sites.olt.ubc.ca/files/2020/06/Take2-2020-02-WP_Blue-Growth-and-Blue-Justice-IOF-Working-Paper.pdf)
2. Aparna Roy; Blue Economy in the Indian Ocean: Governance Perspectives for Sustainable Development in the Region; Year: January 2019
3. Christina Emmanouil, Athanasios Kungolos The challenges of Blue Economy: Marine pollution, Port and Shipping Sustainability; Year: May 2019
4. Handbook on fisheries statistics 2020; Ministry of Fisheries, Animal Husbandry & Dairying, Government of India, New Delhi
5. India’s Blue Economy: A Draft Policy Framework; Year: September 2020  
<https://moes.gov.in/writereaddata/files/BlueEconomyPolicy.pdf>
6. Martin R. Stuchtey, Adrien Vincent, Andreas Merkl, Maximilian Bucher; Ocean solutions that benefit People, Nature and the economy  
<https://www.oceanpanel.org/ocean-action/files/full-report-ocean-solutions-eng.pdf>  
[https://en.wikipedia.org/wiki/Blue\\_economy](https://en.wikipedia.org/wiki/Blue_economy)

# **INDUSTRY 4.0, SHIPPING AND PSYCHOLOGICAL WELL-BEING AT SEA**

Janhavi J.

Student at Department of Psychology

Fergusson College, Pune

janhavi.n.junnarkar@gmail.com

## **Abstract:**

The paper talks about the potential psychological implications of maritime industry digitization and automation on seafarers' careers. The responsibility for adaptation to Industry 4.0 should not be placed solely on seafarers but on other stakeholders, in order to strategically design future maritime career opportunities to build capacity for the sustainable maritime industry. It concludes with a set of agendas to support individuals from their journeys of education to profession in this transition. From counselling, training to psychometrics; there is a great need for industrial and organizational psychology and mental health professionals to involve in the marine industry.

**Keywords:** Industry 4.0, Shipping, Seafarers, Psychology, Mental Health

## **Objective:**

To identify and explain the importance of mental health and well-being of seafarers in the advancement of marine industry. To review of the work happening in this area across within the society and put forward the outcome to attract attention of the seafarers, the marine industry and other stakeholders of the shipping.

## **Introduction:**

### **Global Shipping**

The global shipping industry is undergoing the industrial revolution. Shipping is one of the oldest trades and is a very important industry amongst many other industries. Around 80 per cent of global trade by volume and over 70 per cent of global trade by value are carried by sea and are handled by ports worldwide [1]. The people who are responsible for the safe operations of this import and export process are called seafarers, who work on these vessels for months together facing rough weather, stringent inspections, disturbed sleep and many other hardships. Seafaring is a practical and challenging profession that requires fast and correct analyses of situations, as well as rapid, decisive action.

### **Industry 4.0**

In the paper of United Nations Industrial Development Organization (UNIDO), it is stated that, "Industry 4.0 is one of the major drivers of the Fourth Industrial Revolution".[2] The word "Revolution" implies "a profound change in economic systems and social structures". However, there is no literature that distinguish these two terms in detail. In the paper, "Industry 4.0", and "the fourth industrial revolution" are used synonymously [3].

Industry 4.0 is revolutionizing the way companies manufacture, improve and distribute their products. Manufacturers are integrating new technologies, including Internet of Things (IoT), cloud computing and analytics, and AI (Artificial Intelligence) + ML (machine learning) into their production facilities and throughout their operations. Aspects such as increased automation, predictive maintenance, self-optimization of process, improvements in the systems, and above all, a new level of competencies and responsiveness to customers not previously possible, can be achieved due to the digitisation of industries. Concepts of industry 4.0 and technologies can be applied across all kinds of industries, including niche, isolated and process manufacturing industrial segments such as oil and gas etc [4].

Just like any other industry, the shipping industry is also undergoing the industrial revolution. Shipping is one of the oldest trades and is a very important industry amongst many other industries. Around 80 per cent of global trade by volume and over 70 per cent of global trade by value are carried by sea and are handled by ports worldwide. The industry has experienced several industrial revolutions since the late 18th century when water- and steam-powered mechanisms fast-tracked the manufacturing of goods. [5] The shipping industry has profited directly from these technological advances in terms of increased trade across the oceans and improved ship design technology, followed by mass production during Industry Revolution 2.0 in the 19th century. During the 20th century, the first computers and automation were introduced as part of Industry 3.0 [6]. In line with this, shipping has considerably increased its cargo volume as well as the opportunities for maritime careers, including sea- and shore-based jobs [7]. Looking at developments in the 21st century, human activities and single components job tasks started to convert to data. Various digital systems have become immaculately interconnected under cyber physical systems, under the promise of innovative solutions and opportunities in industries. As part of this trend, the maritime industry also started to see a new horizon of technological development, one of them being autonomous ships. The movement brought into attention that the responsibility for adaptation to Industry 4.0 should not be placed solely on seafarers but on other stakeholders, including shipowners and other industry players, governments, and MET institutions, in order to strategically design future maritime career opportunities to build capacity for the sustainable maritime industry [8].

### **Methodology:**

This is concerned with detailing and developing the research methodology adopted for data collection, treatment, comparison and verification of the viewpoints of stakeholders to measure the present condition of the workforce and the culture developed in the shipping industry. This discusses the philosophy of framing and designing the questionnaires and the tools and techniques used to process and analyze the findings. The spirit behind this study felt necessary because shipping demands the shared dedication and commitment to safe, efficient and sustainable operations in the maritime industry.

### **Research Questions:**

While organizing thought process and then recognizing a range of questions may be proposed on the topic of organisational positive psychology and well-being at sea, a number of selected research questions are presented below:

1. Do positive psychology interventions and training enhance well-being, performance and safety in the workplace, and through what mechanisms do these interventions and training operate?
  2. Are these mechanisms transferable to the maritime environment?
  3. What are the facilitators and barriers to the effective implementation of organisational positive psychology interventions that are specific to the maritime context?
  4. Do organisational positive psychology interventions show signs of effective maintenance in the maritime context?
  5. Do positive psychology interventions present any advantages or disadvantages relative to other forms of psychological intervention in the maritime context?
  6. How can positive psychology interventions and training be designed and administered to be accessible across ranks, genders, ages, cultures and ethnicities on board?
  7. Are positive psychology computer-based interventions and training an effective and viable option in the maritime context?
  8. How can a systems-based approach to research and implementation be designed to facilitate integrated health care interventions in the maritime environment?
- Through such and more questions suitable to industrial positive psychology, the study further enhanced to know more about the challenges in the industry.

### **Challenges and Stresses in the Industry:**

Despite the endurance of this industry, roles and skills at sea have changed over the centuries-roles like radio officer and carpenter no longer exist, and some roles like administrative officer and a technician that did not exist in the past exist now. In the era of digitisation with so-called “Industry 4.0”, seafarers are increasingly expected to adjust and advance their skills to be more digitally sound [9].

In order to survive in the sea, seafarers have to deal with a lot of challenges and stresses on the sea. There are varieties of stressors and not limited to the following mentioned in Table 1.

**Table 1:** *Types of Stressors*

|                                      |
|--------------------------------------|
| 1. Physical stressors                |
| 2. Psychosocial stressors            |
| 3. Social stressors                  |
| 4. High work demand                  |
| 5. High management tasks             |
| 6. The stress of handling technology |

The newest stressor that has added to the list is stress of handling technology. According to one recent study, the total percentage of all maritime accidents attributable to human error is 75%. There are many factors that may be seen as undermining seafarers' mental health and wellbeing. Some of these factors are universal and are seen across the occupations and other factors are more shipping industry related [10]

### **Generic Factors Affecting Mental Health:**

The study found that generic predisposing factors adding to mental health illness that may be regarded as inherent to the seafaring profession overall include tabulated factors shown below in table 2.

**Table 2:** *Mental Health Affecting Factors*

|                         |                                |
|-------------------------|--------------------------------|
| Isolation               | Fear of job loss               |
| Loneliness              | Separation from family         |
| Lack of shore leave     | Increased terrorism            |
| Fear of criminalisation | Lack of social and family love |

In addition to above, various ship specific factors were all reported as causes for seafarers to feel 'down' or depressed while onboard, and these are tabulated below in table 3.

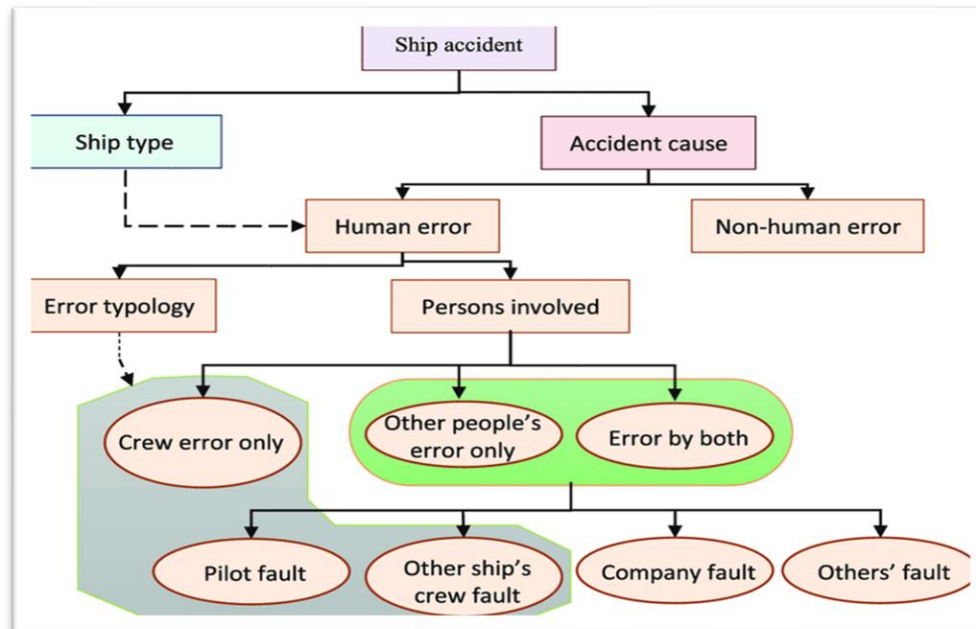
**Table 3:** *Mental Health Affecting Factors Specifically Related to Ship*

|   |   |
|---|---|
| Too much work                                       | Being blamed for things                         |
| Poor food   | Falling out with superiors and other colleagues |
| Crew related factors e.g., having a 'bossy captain' | Multi-tasking persona                           |
| Experiencing discrimination                         | Fast change in knowledge platforms              |

While studies show that there is some evidence that seafaring profession is more prone to mental health problems generally higher among seafarers than non-seafarers and that recent-onset psychiatric disorders have become more common onboard cargo vessels in recent years. The study conducted by Cardiff University and funded by the Institution of Occupational Safety and Health (IOSH) on seafarers' mental health and wellbeing published states that "It is appropriate for industry stakeholders to be concerned about seafarers", mental health and wellbeing and that such worries may be somewhat overdue" [11]. In fact, more than average of the employer respondents stated that their companies had not introduced policies or practices aimed at addressing issues of seafarers' mental health in the last 10 years. The need attracts attention emphasising on proactive measures aimed at improving the mental health conditions of work and life onboard for seafarers.

## Types of Ship Accidents and Causes

Ship being the floating entity, is always prone to risk and hence safe and healthy working practices are more important and becomes the part of the culture of the profession. Figure 1 given below shows the types of the accidents and causes behind them in general when one study the shipping operations.



**Figure 1:** Types of Ship Accidents and Causes

Table 4 shows the one of the recent case study examples, where in, the types of ships and their accidents are numbered based on the points like pilot fault, ship crew errors' fault, company fault and others' fault. This shows the importance of the safety in shipping operations and health condition of the seafaring community.

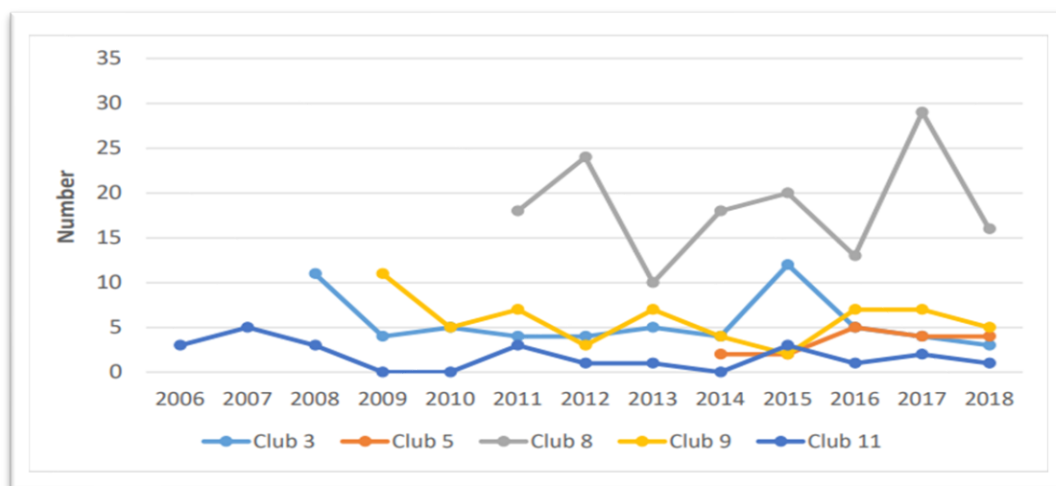
**Table 4:** Classification of Merchant Ships and Causes of Accidents

| Merchant Ships including tugboats and others | Pilot Fault | %     | Other Ships Crew Error | %     | Company Fault | %     | Others' fault | %     |
|--|-------------|-------|------------------------|-------|---------------|-------|---------------|-------|
| Tanker                                       | 8           | 57.14 | 2                      | 14.29 | 2             | 14.29 | 2             | 14.29 |
| Bulk Carrier                                 | 7           | 53.85 | 3                      | 23.08 | 1             | 7.69  | 2             | 15.38 |
| Container ships                              | 6           | 75    | 2                      | 25    | 0             | 0     | 0             | 0     |
| Other Cargo Ships                            | 4           | 50    | 2                      | 25    | 2             | 25    | 0             | 0     |
| Passenger Ships                              | 1           | 5.56  | 3                      | 16.67 | 8             | 44.44 | 6             | 33.33 |
| Tugboats                                     | 3           | 17.65 | 6                      | 35.29 | 5             | 29.41 | 3             | 17.65 |
| Ferry  | 0           | 0     | 2                      | 66.67 | 0             | 0     | 1             | 33.33 |
| Offshore/Supply/Lift boats                   | 0           | 0     | 3                      | 37.50 | 5             | 62.50 | 0             | 0     |
| Drager                                       | 0           | 0     | 1                      | 100   | 0             | 0     | 0             | 0     |
| Barges                                       | 0           | 0     | 1                      | 33.33 | 2             | 66.67 | 0             | 0     |

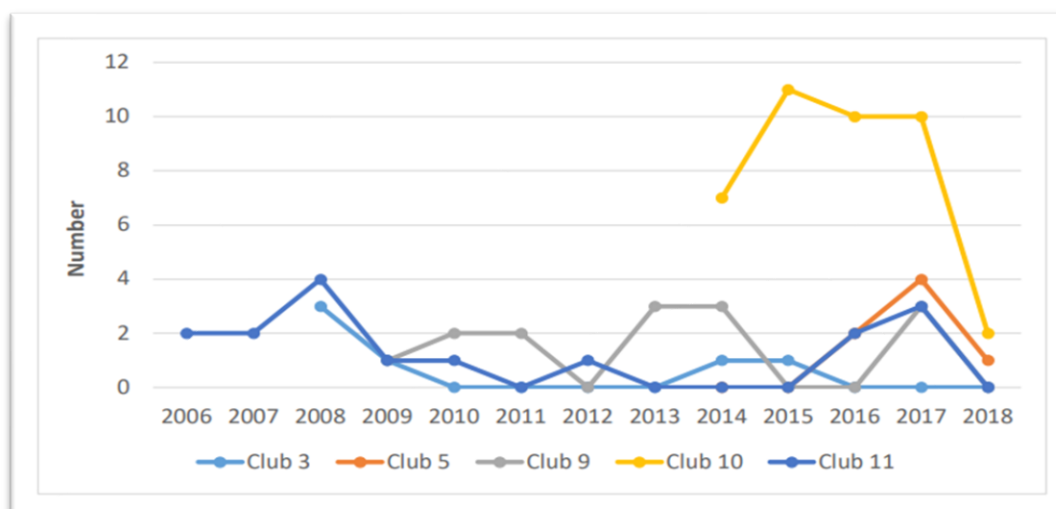
## Role of Protection & Indemnity (P&I) Club

Protection is required for the safe working of seafarers and ships, and indemnity is necessary to compensate for any loss of life, environment and property [12]. P & I club is an association composed of ship owners' members to support seafarers' safety and well-being by providing the required necessities. A Protection and Indemnity or P&I club is a non-governmental, non-profitable mutual or cooperative association of marine insurance providers to its members which consists of ship owners, operators, charterers and seafarers under the member companies. The three essential elements of shipping industry are the ship, the seafarers and the cargo. The common thread connected to all the three elements, is the "Risk". Transporting the cargo involve risk. If ship meets an accident, a shipowner can face significantly monetary losses and there can be damage to the environment, cargo or to the vessel. The risk to the lives of seafarers is kept above all and thus P & I insurance is a significant aspect of sailing.[13]

From the data provided by P&I clubs, it can be determined the percentage of crew illness claims that related to mental health (including suicide cases). The percentage of illness claims relating to mental health issues was found to be 0.9% and the highest proportion was found to be 3.6%. [14] This indicates that mental health claims make up some proportion of overall repatriation cases on the grounds of illness. (See Figures 2 and 3)



**Figure 2:** Number of mental health cases by P&I club



**Figure 3:** Number of suicides\* cases by P&I club

## **Solution to Problems**

Training in mental health awareness will help to ensure that the seafarers and shore based marine professionals who work with seafarers are well prepared for some of the challenges enlisted above. Effective training can have a very positive impact on seafarers' mental wellbeing and reduce the stigma around mental health. If mental health is no longer considered a taboo, seafarers will be more comfortable in seeking help and/or talking about their problems with their supervisor or a colleague. The training can also be useful to seafarers in recognizing if any crew member may be struggling and provide them the confidence to start a conversation. Similarly, it can prepare seafarers and senior staff with the skills needed to effectively respond to a concern on board or within their company. [15,16] Training can also successfully teach participants about the importance of self-care and looking after your own mental health during a voyage.

## **Results:**

The technologies of the future will have a far-reaching impact on socio-technical production systems. Researches on progress on technical requirements have already been launched in different areas. However, these changes also affect the people working in such environments. As fields of research regarding to the implementation of the industry 4.0, ergonomic work systems are already required in the context of demographic change. The relationships between future industry 4.0 technologies requirements and mental demands are not addressed adequately. Therefore, it is necessary to consider it as another field of action for the implementation of the 4th industrial revolution. Results of strategic studies on this topic will support the implementation of the 4<sup>th</sup> industrial revolution.

- Effective Training to the crew members before joining and in between with regular intervals of service
- Introducing the role of organisational positive psychology
- Fare attention to the health management of the ship and the sea going people
- Awareness training on safety and health
- Training on self-care of physical and mental health to reduce the human error and hence accidents

## **Conclusion:**

Positive emotions are good for your health, accumulating empirical evidence is offering support for this anecdotal knowledge, indicating that positive emotions are associated with beneficial psychological and physical health effects. Robust research is important that shows scientifically the relation and effects on well-being and positive psychology interventions administered on board. The intervention should be designed in a way to alleviate and support seafarers' mental health and well-being by identifying the occupational, demographical and cultural factors which may influence how stress is experienced, expressed and mitigated differently by individuals on board.

Although, research on “mindfulness” techniques and resilience training is evident in the navy and broader seafaring settings, to date, application of positive psychology interventions to the maritime industry context has been studied only marginally.

As wellbeing of sea farers is considered to be the primary source of productivity, some shipping companies are seemingly willing to invest. Whether the growing focus of maritime organizations on supporting seafarers' well-being is health or productivity motivated, or both, a snowballing awareness of mental health problems at sea is evident, associated with a variety of practical initiatives in this area.

Importantly, however, a systems-built perspective that addresses safety, cultural, environmental, operational and organizational aspects can guarantee a more comprehensive approach to maritime professionals' health.

### **Acknowledgement:**

I am thankful to the department of Industrial and Organisational Psychology of Fergusson College, Pune for allowing me to take the part in paper presentation. I am thankful to all my faculty members for keeping faith in me and guiding me from time to time. I remain grateful to Tolani Maritime Institute, for making me aware about the field of Merchant Navy and for providing Trantech platform to showcase our study and thrust in academic research.

### **References:**

1. Prof Malcolm MacLachlan (2017); Maritime Psychology: Research in Organizational and Health Behavior at Sea.
2. United Nations Industrial Development Organisation; Industrial Development Report (2020).
3. Phan Kieu Linh (2019); Education in Industry 4.0.
4. IBM; How Industry 4.0 Technologies are Changing Manufacturing.
5. Adrian Wilkinson, Jimmy Donaghey, Tony Dundon and Richard B. Freeman (2020) Handbook of Research on Employee Voice.
6. Whitepaper: Industry 4.0- Revolution in Manufacturing and production
7. Technology and Innovation Report (2018); Harnessing Frontier Technologies for Sustainable Development. UNCTAD.
8. Dr. Polina Baum-Talmor and Dr. Momoko Kitada (2022); Industry 4.0 in Shipping: Implications to Seafarers' Skills and Training
9. Dr. Momoko Kitada and Dr. Polina Baum-Talmor (2019); Maritime Digitisation and Its Impact on Seafarers' Employment from a Career Perspective
10. Gard (2019); Seafarers' Mental Health and Well Being
11. Helen Sampson and Neil Ellis, Seafarers International Research Centre (2019); Sea farers mental health and well being
12. Anish Wankhede (2021); Importance of P&I Club in Shipping
13. ISWAN news (2020); Mental health of seafarers: what has the industry done to tackle this? What else is needed?
14. Roger Harris (2020); Mental Wellbeing and Seafarers
15. Uwe Dombrowski and Tobias Wagner (2014); Mental Health as a Field of Action in the 4<sup>th</sup> Industrial Revolution
16. Joanne McVeigh, Malcolm MacLachlan, Ralf Stilz, Henriette Cox, Niamh Doyle, Alistair Fraser and Marianne Dyer (2017); Positive Psychology and Well-Being at Sea

# STRESS MONITORING SYSTEM (SMS)

Krishang Trivedi<sup>a</sup> and Kartik Gudoo<sup>b</sup>

<sup>a</sup>Tolani Maritime Institute, Pune, krishang.trivedi2020me@gmail.com

<sup>b</sup>Tolani Maritime Institute, Pune, kartik.gudoo2020me@gmail.com

## Abstract:

Automated ships are coming into picture hence reducing the number of people on board ship but increasing the work load of mariners as less people are now required onboard because of automation. Mariners work straight 12-12 hours a day and don't get appropriate amount of sleep which is deteriorating their health in a drastic manner. Our objective is to monitor their activities, their facial expression and their body language throughout their work time only and then by using the AI technology we can make a report which will monitor the amount of stress he/she is facing. Through this at early stage we can detect whether a person is going into depression or not and can monitor his/her stress levels during the working hours. Our goal is simple

-Better Health for Our Mariners

**Keywords:** Stress, Better health, Depression, Anxiety, Facial recognition (AI)

## Introduction:

In this modern world, companies and shipping industries are trying to get fully automated machinery (fully automated ships) so they require less man power on ship, hence increasing the size of their pockets.

The process has already started, reputed shipping companies came up with a new set of recruiting policy for the crew members, they will be removing 4<sup>th</sup> engineers from the ship, hence cutting the cost of 4<sup>th</sup> engineer. Making ships work on fully auto-pilot mode and requiring less man power will surely be the next generation automation in this sector where we will see single man on ship supervising the robots and the automated machinery.

## Main Work:

Companies' policy of a worker onboard is that they should work 48 hours in a week but actually speaking everyone in the marine sector knows the stress which is caused while the mariners are onboard is too high, they actually work 24x7 which is obviously very stressful. After so much advancements made on ships, still mariners' workload is too high. People on board are getting stressed, they are leaving the sails because of the health issues and the stress which they are facing. People cannot sleep sometime for full day which is eventually affecting their health.



**Figure 01:** *A stressed mariner trying to sleep after doing long hours of work.*

#### A) Cardio Vascular Disease

- Various mortality studies revealed the seafarers who die because of CVD is because of common factor such as stress, diet, lack of exercise etc.

With minimum number of crew on board ships, multitasking and lack of leisure and recreation facilities, high stress levels are prevalent

#### B) Musculoskeletal Disorder

- Offshore operations which are carried on ships seafarers work straight 12 hours shift which causes musculoskeletal disorder

#### C) Hypertension

- Major hazard on board ships excessive stress, fatigue, loneliness are causes for hypertension

#### D) Radiation sickness

- Mariners tend to raise the issue when doing monkey island job

Our aim is to make a system through AI technology which will help us to find out the stress level of a person, sleep pattern of a person, depression level of a person, anxiety, mood etc. This will help us to find out above mentioned things at the very early stage and many diseases can be countered through our project. We will set a bar in our AI system, if the standard matches that particular level, the AI will analyze all the criterion and make a report of the particular person. We will also use the concept of cloud computing to tackle these situations. Cloud computing is the on-demand availability of computer system resources, especially data storage and computing power, without direct active management by the user. Large clouds often have functions distributed over multiple locations, each location being a data center. The cloud enables users to access the same files and applications from almost any device, because

the computing and storage takes place on servers in a data center, instead of locally on the user device.

We will use this cloud computing process to store the images captured by our various cameras and then the AI would go through those images and make decisions according to the existing set of data and instructions given to it to judge the condition of the subject. Deep learning will also play a crucial part while making this system.

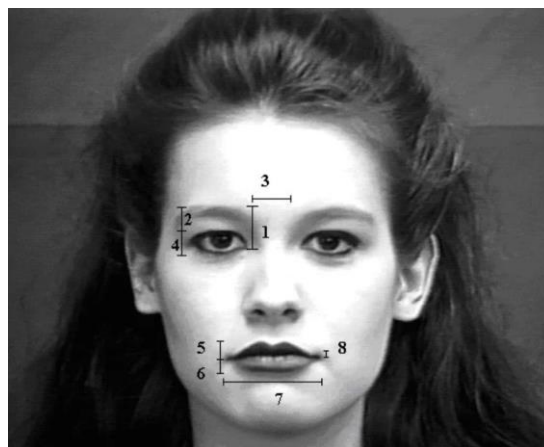
For simplicity let us take an example

There are 2-4 people on board ship. They are working as usual in the engine rooms, on the deck, doing their regular watchkeeping, checking all the automations on the ship whether they are working upto the mark or not, anchoring, cargo unloading-loading and all that stuff. So this increases the work load of a particular individual and obviously stress increases while doing these duties. Since there will be less people onboard ship in upcoming years and more advancement in automation will there. Single person will be responsible for all the machineries. Less people on ship will be the greatest factor for loneliness of a person which will eventually become depression and many problems can arise through this. So in order to counter these situations on ship what we as team what we will do is that we will install cameras on board ship in all the possible working areas other than the bedrooms and toilets( not in any private spacing). These cameras will record the facial expression, body language and other activities of the person, since there will be many cameras installed, now here the AI technology will come in the picture, it will sense all the data feeded by the cameras and accordingly will create charts, graph and all. We will set the limit above which AI will detect stress, depression and all, hence this will ensure that we detect these things at a very early stage and not at the later stage as these are the factors for the above-mentioned diseases. Then AI will make a report and send to the head office and then they will take action accordingly (like telling him/her to take a break, do some recreational stuff, motivate him etc.). We will be also taking the permission from the employee for recording his live actions onboard ship. We could have just made him/her stand Infront of camera and then let the AI do the work but people tend to smile and be confident while they know they will be facing the camera. They become conscious. At that time, we cannot get the exact amount of stress monitored through our AI. So that is why we installed many cameras in order to get real time assessment.

Facial expressions and related changes in facial patterns give us information about the emotional state of the person and help to regulate conversations with the person. Moreover, these expressions help in understanding the overall mood of the person in a better way. Facial expressions play an important role in human interactions and non-verbal communication. Classification of facial expressions could be used as an effective tool in behavioral studies and in medical rehabilitation. Facial expression analysis deals with visually recognizing and analyzing different facial motions and facial feature changes. This would help the shipping companies and seafarers immensely, as we all know that mental health is a major problem that seafarers face in this day and age.

Different parameters which would help AI in identifying facial expressions, sleep pattern, mood, etc. of a person-

1. Eyebrow raise distance– The distance between the junction point of the upper and the lower eyelid and the lower central tip of the eyebrow.
2. Upper eyelid to eyebrow distance– The distance between the upper eyelid and eyebrow surface.
3. Inter-eyebrow distance– The distance between the lower central tips of both the eyebrows.
4. Upper eyelid – lower eyelid distance– The distance between the upper eyelid and lower eyelid.
5. Top lip thickness– The measure of the thickness of the top lip.
6. Lower lip thickness– The measure of the thickness of the lower lip.
7. Mouth width– The distance between the tips of the lip corner.
8. Mouth opening– The distance between the lower surface of top lip and upper surface of lower lip.



**Figure 02:** *Parts of the face we can acquire data for making the result*

Some other secondary parameters could be-

1. Upper teeth visible– Presence or absence of visibility of upper teeth.

2.Lower teeth visible– Presence or absence of visibility of lower teeth.

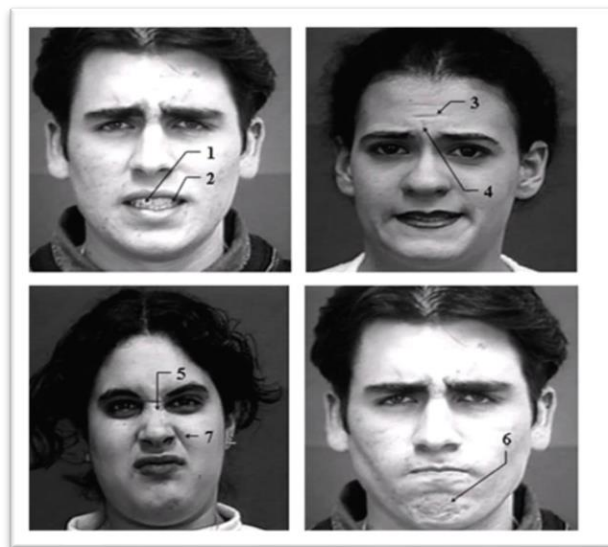
3.Forehead lines– Presence or absence of wrinkles in the upper part of the forehead.

4.Eyebrow lines– Presence or absence of wrinkles in the region above the eyebrows.

5.Nose lines– Presence or absence of wrinkles in the region between the eyebrows extending over the nose.

6.Chin lines– Presence or absence of wrinkles or lines on the chin region just below the lower lip.

7.Nasolabial lines– Presence or absence of thick lines on both sides of the nose extending down to the upper lip.



**Figure 03:** *Parts of the face through which we acquire the data for our AI*

My personal interaction with some seafarers was so disheartening. While onboard they had heart attacks got paralysis which was very disturbing. Paralytic attacks and paralysis are becoming very common in shipping sector due to stress faced by these mariners. It is caused by emotional trauma, depression and when a person is subjected to extreme stress. These particular mental health issues eventually damages physical part of our body and therefore these traumas lead to paralytic attacks or paralysis. In a recent news report we saw similar things happening.

Horrific mortal accidents that took place because other human error. Men at sea tend to be very stressed while working on board which eventually leads to human error(unforced error I would

rather say because of the huge amount of stress these men go through) on ships and these errors lead to disastrous event.



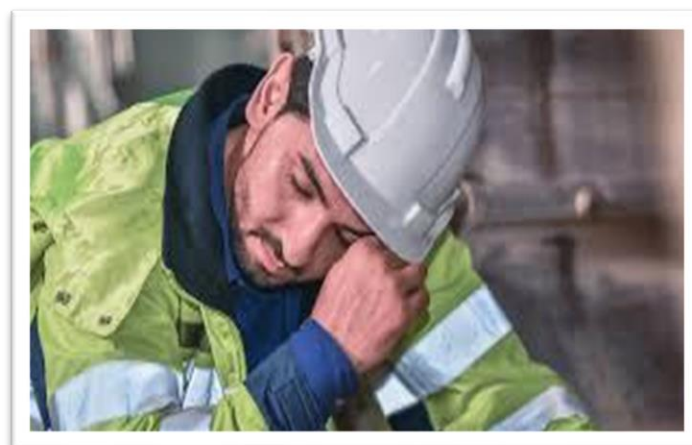
**Fig. 04:** *Mariner died due to drowning and his face also got cut because he came in contact with some sharp object while he fell from the ship.*

As there is progress in UMS, number of people are getting reduced on ships and making people more stressed and vulnerable to hazardous diseases.

Our work is to monitor stress, depression, sleep pattern, approx. number of sleep hours of the marines on board.

Through this we can immediately send the report to the main head office, which will ensure the good health of mariners.

Merchant navy is a kind of profession in which workers are usually exposed to several stress that are related to different duties on board ship.



**Figure 05:** *Tired engineer after subjected to long hours of work*

People see merchant navy as a lucrative and handsome job what they don't know is the hardship these people do onboard. What all they go through in these tough terrains. We as a team would like to extend our hands for the betterment of the mariners.

## **Conclusion:**

- Stress resulting from specific character of this work and environment can noticeably and negatively influence the general sense of the whole life's purpose.
- This will make sure when a person needs a break and this will ensure good health of the mariner and moreover it will help to detect early signs of depression, anxiety etc and suitable arrangements can be done for the mariners at the early stage only.
- This would also increase the working years of the employee which will be beneficial for the company in the long term plus it will also promote a healthy relationship between employee and company.
- Our aim will also be fulfilled by saving people from depression and stress related problems and promoting better health by using the means of technology.

## **Acknowledgement:**

We would like to thank Tolani Maritime Institute for providing us this great opportunity to present our papers in Transtech.

We would like to pay our sincere gratitude to Sanjeet Kanungo sir and Shailendra Kumar sir, Tolani Maritime Institute.

We would also like to express our sincere thanks to Mr. Ravi Kant sir for encouraging us to the peak and to provide us the opportunity for making this project. Without him our project couldn't be a success.

We are immensely obliged to our friends for elevating our inspiration.

## **References:**

1. <https://biomedical-engineering>
2. <https://www.marineinsight.com>

# FUEL CELL AS AN ALTERNATE PROPULSION SYSTEM

Rahul Kumar Singh<sup>a</sup>, Sudeep Ray<sup>b</sup>, Soumojit Chakraborty<sup>c</sup>

<sup>a</sup>Hindustan Institute of Maritime Training, Chennai rahulbgs825@gmail.com

<sup>b</sup>Hindustan Institute of Maritime Training, Chennai sudeep.ray04@gmail.com

<sup>c</sup>Hindustan Institute of Maritime Training, Chennai soumojit9732127278@gmail.com

## Abstract

The objective of the project is to establish the necessity of hydrogen as an alternative fuel in the future and one of the ways to use hydrogen as a fuel for ship propulsion is the use of fuel cells. Zero greenhouse emissions, zero sox, zero nitrogen emissions are some of the properties that makes hydrogen as the best alternative fuel. Hydrogen can be stored in cylinders as well as can be generated on board by electrolysis method.

## Introduction

Requirements of a good fuel:

- High calorific value
- Low moisture content
- Moderate ignition temperature
- Low content of non-combustible matter in the form of ash
- The combustion of fuel is controllable.
- Not give any offensive odour
- Moderate velocity of combustion
- Low cost.
- Fulfil the International, national, and local environmental regulations aimed at reducing Pollution and make shipping Sustainable.

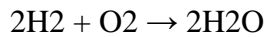
There are four types of hydrogen in terms of the emissions released during production:

- Grey hydrogen - The processing of other natural gas - 71gCO<sub>2</sub>/MJ H<sub>2</sub>, - 75%
- Brown hydrogen - The processing of coal-166 g CO<sub>2</sub>/MJ H<sub>2</sub>,
- Blue hydrogen - The processing of fossil fuels with emission control technologies, including carbon capture, utilization and storage (CCUS) methods
- Green hydrogen - From renewable energy sources, typically via electrolysis using water. Sources of electricity can include solar or wind power to provide net-zero carbon hydrogen production. - 2 %.

## Main Work

**Fuel Cell:** Fuel cell is an energy conversion based device. A fuel Load cell is simple in its operation. It is nothing but electrochemical cell that converts the chemical energy from fuel into electricity. It occurs through the electrochemical reaction of hydrogen and oxygen. There occurs the flow of

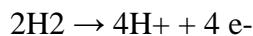
electrons from one electrode to another through the electrolyte. It is clean and environmentally viable option. Here, the energy is liberated by the chemical reaction by the flow of electrons and electrical energy is produced. Here, the products are neither pollutants nor harmful in nature. The electrolysis is being reversed by recombining and the products are water. Hence, the electric current is generated. The hydrogen fuel is being burnt or combustion takes place in simple reaction, which is represented as follows:



There are three components in the structure of fuel cell. They are anode, cathode and electrolyte. The reaction takes place at anode and cathode.

At the anode of electrolyte in the fuel cell, the hydrogen gas get ionises which leads to release of electrons and creating  $\text{H}^+$  ions (or protons).

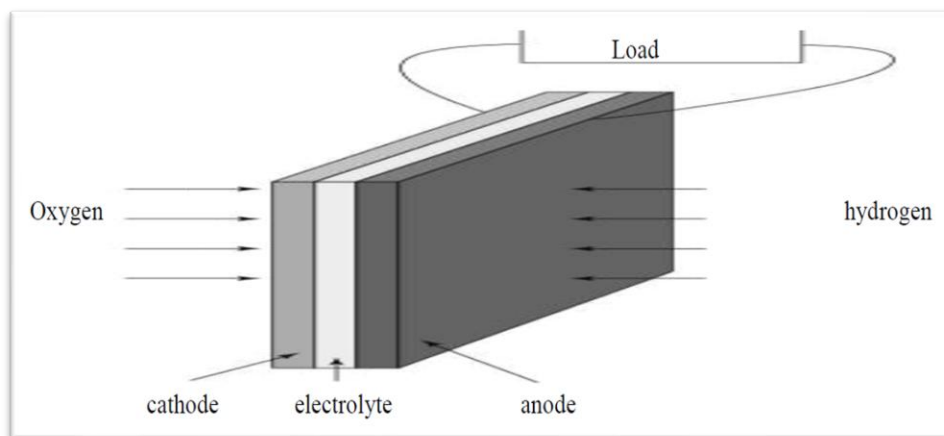
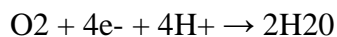
Anode:



This reaction releases energy.

At the cathode, the oxygen gets reacted with the electrons released from electrode and  $\text{H}^+$  ions from the electrolyte. This results in the formation of water.

Cathode:



### **Recent use of fuel cells in shipping industry:**

#### **Energy observer:**

**Energy Observer**, launched in April 2017, is the first vessel autonomous in energy thanks to a mix of renewable energy and renewable hydrogen produced on board. It has started a six-year expedition, scheduled from 2017 to 2022, visiting 50 countries and 101 ports of call including: historical ports, wildlife sanctuaries, natural reserves, endangered ecosystems, and international events to spread the awareness.

#### **Benefits Of Hydrogen:**

- Carbon and Sulphur free

- Can be produced renewably from electrical energy and biorenewable processes
- Can be stored and transported as a liquid or gas
- Established commercial product on land
- Gaseous, particulate matter and GHG free emissions with fuel cells
- Highly buoyant and disperses if leaked, even at liquid hydrogen temperatures
- Hydrogen is a zero-carbon marine fuel when it is consumed in a mono-fuel internal combustion engine.
- Hydrogen fuel blends reduces exhaust gas emissions and GHG footprint.
- Co-combustion with diesel fuel reduces of (NOx) emissions.
- The highest energy content per mass at 120.2 MJ/kg
- Mass energy of H<sub>2</sub> exceeds MGO by 2.8 times, and alcohols by five to six times. So, hydrogen fuel increases the effective efficiency of an engine and help reduce SFC.
- Non-toxic

**Disadvantages:**

- More space requirement
- Due to its lower volumetric energy density, more storagespace required.
- Hydrogen requires low temperatures below -253° C (-423.4° F) to liquefy.
- The necessary layers of materials or vacuum insulation for cryogenic storage and other structural arrangements.
- Fire Hazard
- Flammable properties and wide flammability range.
- Flammability range increases when mixed with pure oxygen
- Very low ignition energy, min. 0.02 mJ
- Quick formation of flammable gas mixture. ‘
- Electrostatic charges.
- All hydrogen handling equipment is to be protected from electric charge build up and potential sparks.

**Conclusion:**

Fuel cells can be one of the best alternatives for IC engines. Energy produced from the green hydrogen will only be considered as the most environment friendly and most efficient. But the production of green hydrogen is comparatively less, so by investing in the green hydrogen production and making a proper bunkering facilities and infrastructure for hydrogen fuel, fuel cells can definitely replace the dependency of marine industry on hydrocarbon fuel.

**Acknowledgement:**

C/E S. Paranthaman (Faculty- HIMT College)

**Reference:**

1. <https://www.ijert.org/research/fuel-cell-and-its-applications-a-review-IJERTV7IS060019.pdf>

# ALTERNATIVE PROPULSION SYSTEM

Aman Kumar<sup>a</sup>, Ankit Kumar Sahu<sup>b</sup>, Anish G Anchan<sup>c</sup>

<sup>a</sup>Tolani Maritime Institute, Pune aman.kumar2020me@gmail.com, 7992334907

<sup>b</sup>Tolani Maritime Institute, Pune ankit.sahu2020me@gmail.com, 9975580617

<sup>c</sup>Tolani Maritime Institute, Pune anish.anchan2020me@gmail.com, 9028288046

## Abstract

In recent years, the plan of ship propulsion system has been focusing on energy productivity and low poison discharges. To accomplish environmental change targets, new ship requests ought to be fit for conveying zero emanation drive from 2025. The pathway towards this is muddled and requires huge venture. This study analyses the design in contemplations of the capacity of elective powers for board large scale worldwide vessels, with a specific spotlight on alkali, hydrogen and methanol. Additionally, hydrogen has an apparent low volumetric energy thickness, but the determined volume required.

**Keywords:** Methanol; Ammonia; Hydrogen; Fuel cell; Diesel-electric propulsion system; Greenhouse gas (GHG); Zero-carbon fuels; Solar power

## Introduction

Expanding ecological concerns are driving the shipping industry to go to severe lengths to manage greenhouse gas emissions. International Maritime Organization drives the industry to see as more proficient and environmentally friendly power systems. To alleviate destructive emissions, explores on marine alternative fuels, functional upgrades like slow steaming or prescient maintenance, and extra emission abatement technologies are not adequate. The use of electricity as the fundamental energy vector is one of the ways of further developing the shipping propulsion system's efficiency. In this study, power generation innovations, energy storage components, and hybrid propulsion topologies are assessed. Diesel-electric engines, fuel cells, nuclear and solar power as sustainable energy sources are considered as power generation units.

## Hydrogen fuel cell & Ammonia

Fuel cells are another alternative propulsion technology being investigated, with pilot programmes for big passenger ships already underway.

Fuel cells are electrochemical cells that convert hydrogen or other hydrogen-carrier fuels into electricity, allowing ships to run on electricity without releasing harmful pollutants or particulates. Other fuel cell types employ direct fuels such as diesel, methanol, and methane, though this does not reduce emissions as much.

While this is an appealing alternative for shipowners, fuel cells are still in the early stages of being adapted for marine use and face a number of obstacles. It is costly to outfit a ship with hydrogen fuel cells as well as to modify vessels that do not currently use electric propulsion.

Zero-carbon fuels like ammonia and hydrogen have a lot of potential to reduce shipping's carbon emissions, especially when employing the tank-to-wake requirement. However, when compared to conventional fuel oils like HFO, one of the disadvantages of alternative fuels is their reduced energy content. This is particularly true for hydrogen; nevertheless, because ammonia is a more volumetric efficient hydrogen transporter, it could be a viable zero-carbon. The use of ammonia as a fuel is predicted to increase due to its zero-carbon content, ease of distribution, storage, and bunkering compared to hydrogen, and compatibility with present and developing technologies for propulsion and power generation transportation options.

### **Advantages**

- ◆ Carbon-free - no CO<sub>2</sub> or soot
- ◆ Low flammability risk – 15.15% to 27.35% in air
- ◆ Can be produced from electrical energy – renewable
- ◆ Easily reformed to hydrogen and nitrogen
- ◆ Can be stored and transported as a liquid at a practical pressure and temperature
- ◆ Established commercial products

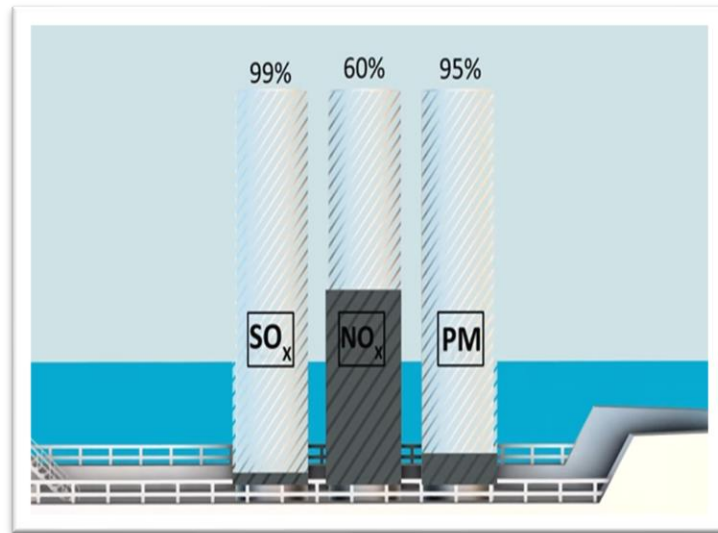
### **Challenges**

- ◆ Toxicity
- ◆ Fuel infrastructure
- ◆ Lack of regulations
- ◆ Engine development at the design stage
- ◆ Cost
- ◆ Corrosiveness to certain materials
- ◆ Poor combustion characteristics for IC engine application
- ◆ Possible need for the high percentage of pilot fuel
- ◆ Possible increased NO<sub>x</sub> emission, Possible ammonia slip

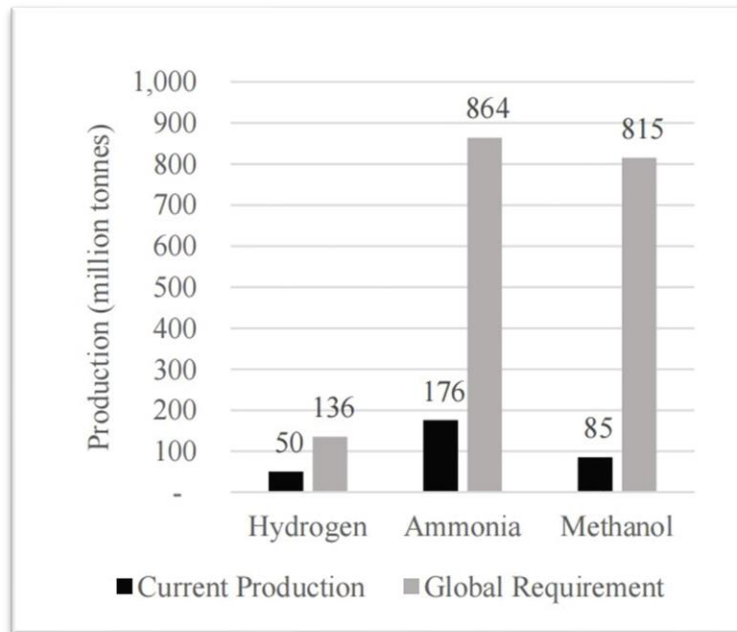
### **Methanol**

Methanol is clean-burning, biodegradable, economical has become an important trading commodity in recent years, and growth is projected to accelerate in the future. Because of the rising demand for cleaner marine fuel, methanol is an alternative fuel for ships that helps the shipping industry meet more stringent emissions criteria.

Methanol's clean-burning qualities as a marine fuel reduce emissions of sulphur oxides by approximately 99 percent, nitrogen oxides by up to 60 percent, and particulate matter by 95 percent, according to new environmental regulations from the International Maritime Organization and countries around the world.



A clear biodegradable liquid methanol is produced from natural gas and can also be made from renewable resources. Essentially future-proofing it has long-term sustainable fuel methanol is a cost-effective alternative marine fuel in terms of storage and fueling infrastructure, as a liquid fuel only minor modifications are needed for current fuel infrastructure to handle methanol. Similarly, the cost for new builds and to convert vessels to run on methanol is significantly less than alternate fuel conversions. Today methanol is one of the world's most widely shipped chemical commodities and has a long history of safe handling for over a hundred years methanol has been shipped globally handled and used in a variety of applications, now there are great examples of innovative companies looking at using methanol as a marine fuel like the world's global leading ferry operator did in 2015 with the standard germanica ferry this is the world's first methanol powered ferry operating in the Baltic Sea this standard germanica is powered by four wärtsilä four-stroke methanol compatible engines as well engine manufacturer MAN is also supplying dual-fuel engines that can run on conventional fuel and methanol. Waterfront shipping the wholly-owned subsidiary of Methanex operates the world's largest methanol ocean tanker fleet and has been instrumental in the evolution of methanol as a viable fuel option for the shipping industry. In 2013 waterfront shipping signed an agreement with its partners to build seven new ships with MAN's dual-fuel engines that can run on methanol launching,2016 these seven ships the world's first two-stroke dual fuel methanol vessels, will join the waterfront shipping fleet in 2016 and represent a revolutionary introduction to global marine transportation clean burning methanol can fulfill new International Maritime Organization emission requirements and provide fuel flexibility, safe, clean burning, cost-efficient, sustainable, inventive, and available across the world methanol is the marine fuel of today and tomorrow.



Current annual production levels compared to the estimated annual demand for 50,000 ships

### LPG-LNG

LNG, in conjunction with new technologies and operational measures, has the potential to meet the 2030 emissions-reduction targets. There are several factors to consider when using LNG as a marine fuel, including:

- LNG is a dynamic fuel
- LNG fuelled ships require special considerations
- Crews should receive additional training.

LNG as Marine Fuel offers a practical solution to these issues, assisting owners and operators in making decisions about future ship designs, propulsion systems, and fueling strategies.

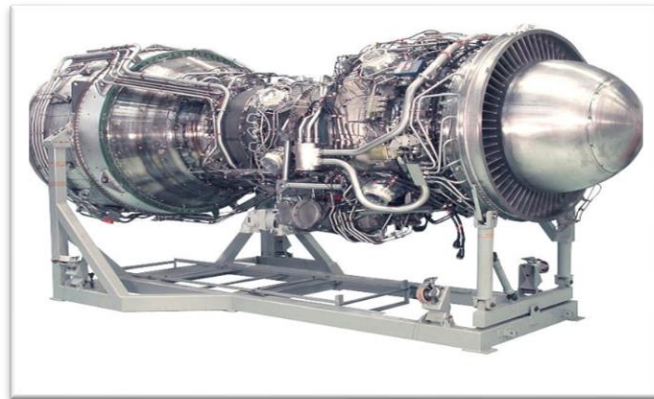
LPG is widely available around the world and is praised as a clean, energy-efficient, portable fuel with a low price tag. Currently, it is primarily derived from natural gas and oil production activities. However, thanks to new technologies and techniques, LPG can now be produced from renewable sources as well.

Because it is a mixture of propane and butane, it has a higher density than air, which means that if there is a leak, the vapours will collect in the lower portion of the surrounding space. As a result, leak detection and ventilation are handled differently than with LNG. In addition, LPG has a lower flammability range, with a 2% lower explosion limit.

The World LPG Association (WLPGA) recognizes LPG's growing utility in shipping. According to its recent research, 'LPG Bunkering Guide for LPG Marine Fuel Supply', 'LPG is a crucial enabler for the IMO's 2050 standard, which asks for a 50% decrease in total annual greenhouse gas emissions by 2050 compared to 2008.

## **Gas Turbine Propulsion**

Gas turbines were first brought into warship propulsion during the 1950s to work with high-speed sprint methods of operation since their power density was high. A further functional benefit was the general ease with which gas turbines could be started and stopped which gave fast admittance to high levels of power. Gas turbines can be utilized either in simple mechanical propulsion drive configurations or on the other hand to produce electricity, which is then utilized by electric drives to propel the ship.



Gas turbines have the benefit of being low weight when compared to diesel engines. This weight advantage, consequently, permits designers significant adaptability in locating gas turbines in a ship when a turbo-electric drive is indicated. The advanced present day aero-derivative gas turbine units are intended to consume industrially accessible distillate fuels which meet the current regulation on emission and smoke necessities. Distillate fuels, notwithstanding, are extensively more costly than the conventional marine fuels consumed in diesel engines utilized by merchant ships.

## **Diesel-Electric Propulsion**

Traditional Ship Propulsion system fundamentally depends on thermal engines, like diesel Engines or gas turbines, precisely associated with either fixed or controllable Pitch propellers, more often than not through a decreased gear. This propulsion plant layout has a few clear benefits, for example, is founded on straightforward and very much combined Technologies, guaranteeing unwavering quality and safety. Also, it depends on a few Productive energy changes, guaranteeing a somewhat high generally speaking propulsion effectiveness while working in plan conditions.

In ongoing many years, diesel-electric drive has developed as a decent contender for ship propulsion, carrying a few extra advantages of working adaptability and decreased footprint emission. This kind of propulsion system has a few downsides due to extra energy changes that influence the general productivity at the most extreme speed.

Then again, the advantages as far as design adaptability are direct. Neither shaft-line nor one of the gearboxes should be introduced, permitting the machines to be apportioned all the more proficiently in the accessible spaces, diminishing the vessel's acoustic mark and commotion

light. Additionally, there is no mechanical connection between the power age and the propeller shaft, permitting more adaptable control of the two motors' and propellers' transformation speeds. Ultimately, the power request can be divided among the diesel generators(D/G) with more levels of opportunity, transport wellbeing and accessibility advantage, and hardware overt repetitiveness. These angles pushed transport architects to consider diesel-electric propulsion for traveler ships, naval force ships, and different unique units.

The likelihood to keep up with the D/G in ideal working circumstances makes diesel-electric propulsion a compelling answer to meet the severe contamination guidelines upheld these days by the International Maritime Organization (IMO). As such, a diesel-electric propulsion structure is one of the cutting-edge reactions to the plan of energy-proficient and harmless to the ecosystem ships. A critical improvement to the proficiency of diesel-electric propulsion frameworks is because of the new presentation of variable unrest speed generators, permitting the diesel motors to work in their ideal proficiency conditions. This kind of motor control rationale is combined with direct current (DC) dissemination all together not to oblige the alternators to delivered energy at a decent appropriation recurrence, rather than substitute current (AC) dispersion.

Diesel-electric propulsion is considered for power production and propulsion. The three fundamental viewpoints to consider while thinking about a diesel-electric framework as a possibility for transport drive are:

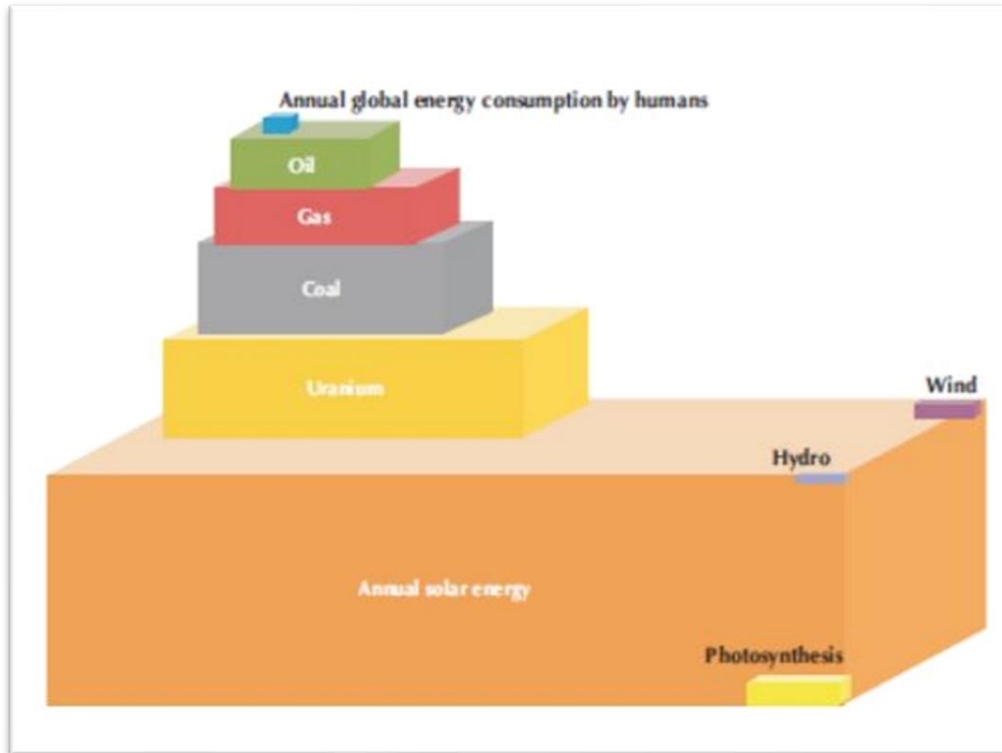
- Drive power interest and the electric burden expected for auxiliary services are tantamount; the effectiveness gap to mechanical drive probably won't be an issue;
- The working adaptability may be a benefit for those ship types that have very different working profiles, portrayed by, for instance, totally different boat speeds;
- The design adaptability could prove to be useful while thinking about a boat with restricted Spaces ready or when the low commotion level is a plan rule.

## **Solar Propulsion**

The environmentally friendly power catch for a ship's propulsion framework was upgraded for a blend of wind sail and sun oriented power utilizing two models. The primary model advanced the inflexible breeze sail point under changing breeze conditions, while the subsequent model enhanced the accessible deck region of the boat allotted to wind and nearby planet groups to expand absolute power creation.

The ideal power got from the outcomes was utilized in the Energy Efficiency Design Index computation to assess the carbon dioxide outflow decrease per unit transport work. For a situation concentrated on utilizing a mass transporter vessel, the outcomes showed that cruising at ideal sail point and upgrading the accessible deck region with the consolidated establishment of sunlight based and wind framework permitted augmenting the sustainable ability to contribute a 36% decrease of carbon dioxide outflows contrasted with similar boat without inventive innovations. It was reasoned that assuming the boat speed was decreased to 56% of

its unique speed, the boat could cruise on sustainable power caught on-board as it were. The created procedure can be utilized during both boat plan and activity stages as an appraisal apparatus, for mass transporters as well as different sorts of vessels with a fitting.

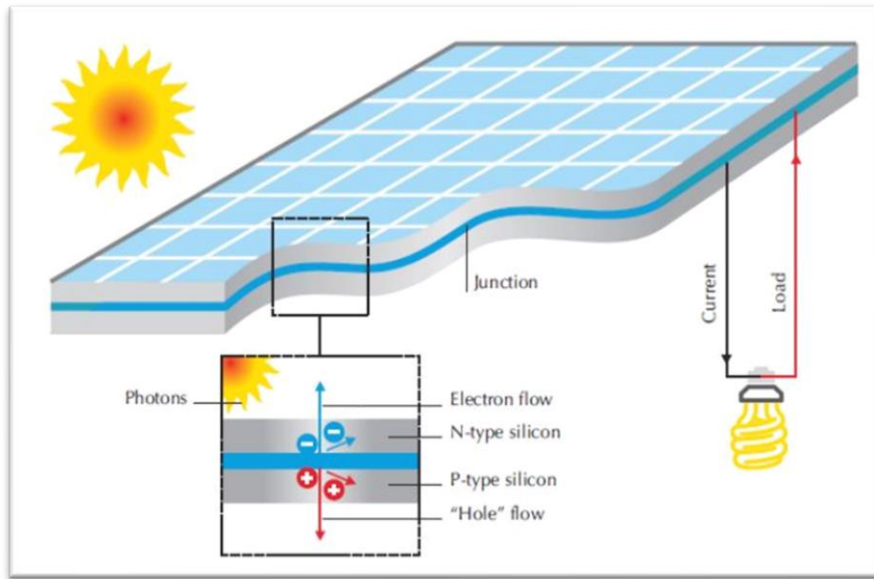


Total

Energy Resources of The World

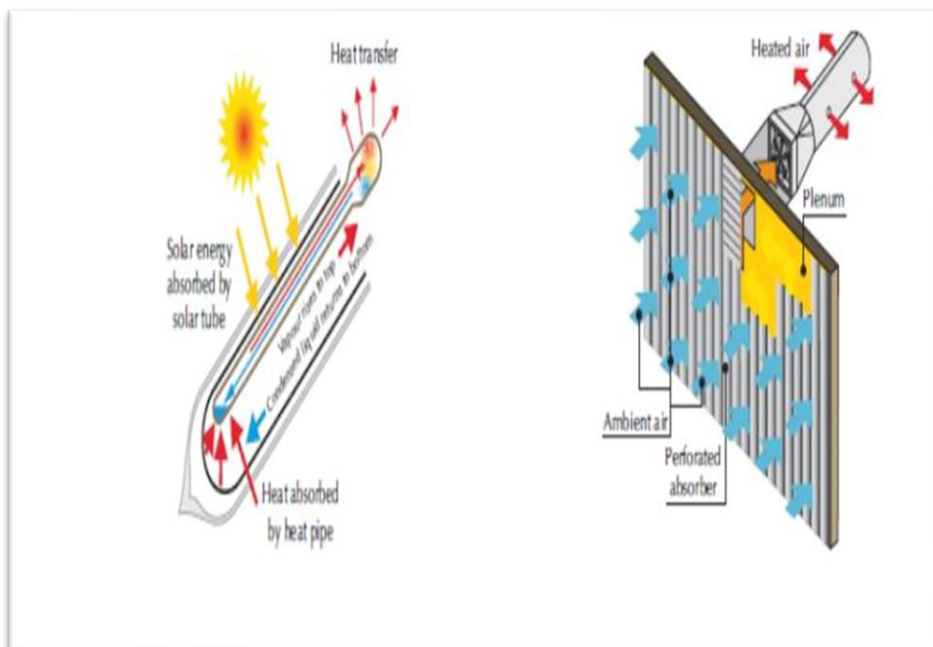
Sun powered innovation includes the utilization of semiconductor materials to bridle energy of the sun and convert it to heat and electricity. The semiconductor materials which are called photovoltaic cells empower the quantum of sun powered energy called photons falling on it to drive electrons from the atomic grid of the material. This impact was first seen in the early piece of the nineteenth century by Alexandre-Edmund Becquerel, that power was produced using specific light-instigated substance responses. The materials which are utilized in semiconductors are changed however translucent silicon right now has the biggest portion of the market with around 90%. Others incorporate variations of silicon like nebulous silicon and multi-intersection (heterogeneous) slim film. Cadmium-tellurium and Copper-indium are additionally other types having a place with the dainty film. The idea of the precious stone that gives it novel capacity for the creation of power through the development of electrons in the grid is best outlined in the tetrahedral design of the silicon particle. Every molecule even with the tetrahedron structures bond with four different iotas at the vertices in which just two electrons are utilized in the bond. The arrangement of the bond makes a valence band, as the external shells of the atoms are not filled. At the point when light falls on the crystal of the electrons in the valence band are invigorated and solely after getting adequate energy they move to the following energy band called the conduction band. Openings or positive charges are made afterward. This progression of negative charges (electrons) and positive charges

(openings) creates power inside the precious stone. The figure underneath shows the exhibition of this peculiarity.

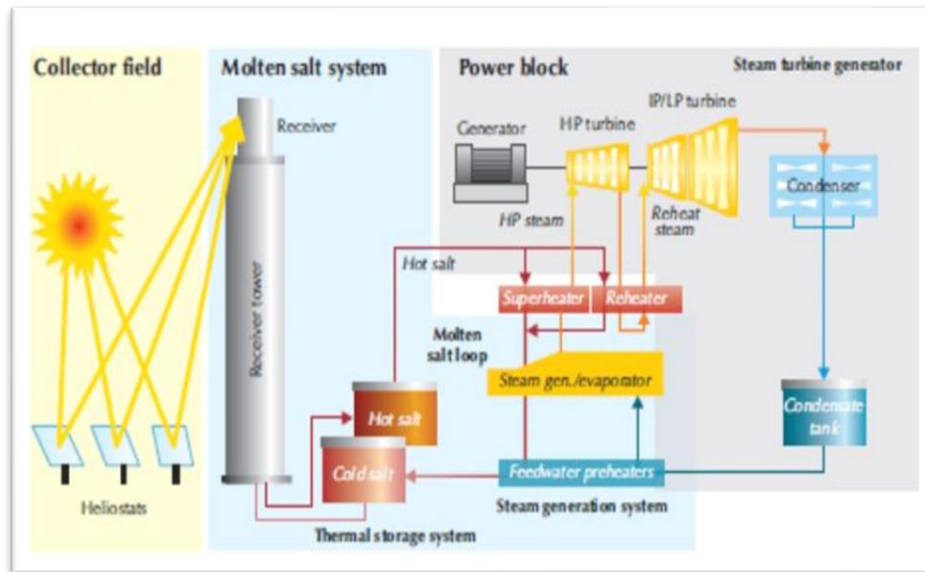


### Photovoltaic Effect on Semiconductor

The other solar based innovations convert sunlight-based radiation into heat for the end goal of heating or use it to produce electricity



### Solar Heaters for heating



## Solar Thermal Electricity

Besides PV innovation, two different advancements, which are utilized to create power straightforwardly from the sun, are the Concentrated PV (CPV) module, and Natural Cells. The CPV module as displayed in the above figure is made of focal point and mirrors to focus sunlight based radiation on high proficiency cells, which catch an explicit band of sun based radiation range. Higher module proficiency of 25% is cited about them however the expense of production offsets the advantages acquired from higher effectiveness. The concentrated sun oriented radiation is utilized to work a power-producing gadget like a Sterling motor or gas or steam turbine. CPV is more productive in catching the sun's energy than PV because of its plan and capacity to follow the position of the sun.

## Nuclear Propulsion

Existing onboard energy storage and power generation systems dominantly foster power by breaking chemical bonds between molecules. Conversely, nuclear power generation is the fission of huge, heavy nuclei into smaller fission products under controlled chain responses. This delivers a large amount of heat energy which is moved to a coolant to create useable power by means of a suitable thermodynamic cycle. Nuclear propulsion, hence, addresses a possibly radical solution by being a CO<sub>2</sub>-free propulsion source while working

There are a few potential fuels, methods of fission, and reactor coolants that could be utilized for merchant ship propulsion. In any case, the most widely recognized reactor type is the uranium-fuelled compressed water reactor. Natural uranium includes three isotopes: <sup>238</sup>U, 99.3%; <sup>235</sup>U, 0.7% and <sup>234</sup>U, 0.005%.

One more likely source of fissionable uranium fuel is thorium which is more abundant than uranium and regularly exists in the soil in convergences of around 6 ppm. Advancement in different parts of the world is being attempted to produce a robust reactor for this fuel source which has a further benefit in that the half-existences of the illuminated products are generally considerably more limited than those from natural uranium-based fuels.

## Conclusion

The marine propulsion engine market is driven by the requirement for faster, cleaner, and eco-friendly engines. Less carbon-radiating options are preferred since they conform to rules and guidelines. The different kinds of propulsion systems offer their own special benefits to a vessel. Contingent upon the need and the prerequisite, the best sort of ship propulsion system should be fitted. Only at that time, the vessel will offer its ideal service capacitance. It is clear that to upgrade the potential benefits of a propulsion option or combination of choices, as far as productivity and limiting the effect on the climate, an integrated ship design procedure based on a systems engineering approach should be utilized.

Supporting these potential choices is a requirement for additional sufficiently put-together techno-economic studies for target outflows from ships.

## References

1. Campora, U.; Cravero, C.; Zaccone, R. Marine gas turbine monitoring and diagnostics by simulation and pattern recognition. *Int. J. Nav. Archit. Ocean Eng.* 2018, 10, 617–628.
2. Shi, W.; Grimmelius, H.; Stapersma, D. Analysis of ship propulsion system behaviour and the impact on fuel consumption. *Int. Shipbuilding. Prog.* 2010, 57, 35–64.
3. Clausen, N.B. Marine diesel engines: How efficient can a two-stroke engine be. In *Proceedings of the STG Ship Efficiency Conference, Hamburg, Germany, 28–29 September, 2009.*
4. M. Hirscher, "Handbook of hydrogen storage," *Topics in applied physics*, vol. 12, 2010.
5. R. O'Hayre, S.-W. Cha, W. Colella, and F. B. Prinz, *Fuel cell fundamentals*. John Wiley & Sons, 2016.
6. U. Bossel and B. Eliasson, "Energy and the hydrogen economy," *Methanol Institute*, Arlington, VA, 2003.
7. C. Zamfirescu and I. Dincer, "Using ammonia as a sustainable fuel," *Journal of Power Sources*, vol. 185, no. 1, pp. 459-465, 2008.
8. N. Ash, I. Sikora, and B. Richelle, "Electrofuels for shipping: How synthetic fuels from renewable electricity could unlock sustainable investment in countries like Chile," *Environmental Defense Fund*, London, 2019.

# HYBRID ENERGY REGENERATING SYSTEM

Atul Sharma<sup>a</sup>, Chirayu Mahajan<sup>b</sup> and Clint Yesudas<sup>c</sup>

<sup>a</sup>Tolani Maritime Institute, Pune atul.sharma2020me@gmail.com

<sup>b</sup>Tolani Maritime Institute, Pune chirayu.mahajan2020me@gmail.com

<sup>c</sup>Tolani Maritime Institute, Pune clint.yesudas2020me@gmail.com

## Abstract:

Renewable Energy is a clean and non-renewable energy source, Ocean Power is one of the renewable energy sources capable of providing more than 2 TW of global energy supply. Among all the available wave power converter technology, the point-absorber is one of the most promising solutions today, due to its ease of construction and installation. Floating point-absorber WECs (wave power converters) are often exposed to rough or inland oceans with high uncertainty of natural loads, making testing their reliability a challenge. Rotor sails are one of the best ways to convert air into mechanical power. These rotor sails are cheaper to maintain and maintain compared to other cruise ships. This is a fuel-efficient and efficient system for most vessels, and can be used on any route.

**Keywords:**WEC-Wave Energy Converters, PTO-Power Take-Off, FEA-Finite Element Analysis,

## 1. Introduction:

Climate change, increasing energy demand globally, rising industrialisation, and population growth rate are just four of the driving factors that constitute clean, sustainable, and renewable energy – one of the world's priorities that can enable further development. Since wind and solar energy combine well with natural resources, they have garnered significant attention so far; however, in the last decade, technologies are receiving more attention. Ocean wave energy is a clean and inexhaustible resource, able to provide more than 2 TW of energy supply worldwide.Coastal countries are attracted to wave energy because it is topologically predictable and consistent, as well as having a high energy density.

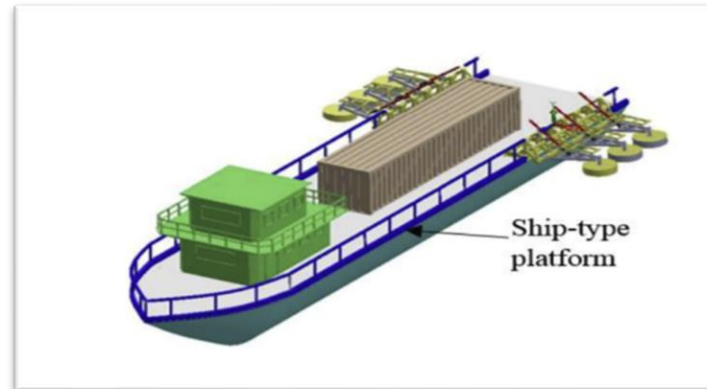
## Wave Energy Converters:

### Working Principle:

Wave energy converters (WECs) are devices that convert the kinetic and potential energy associated with a moving ocean wave into useful mechanical or electrical energy.

Floater is one of the most important parts of the whole device. Despite the fact that many different types of WECs are patented, only a few of them have been developed and installed in

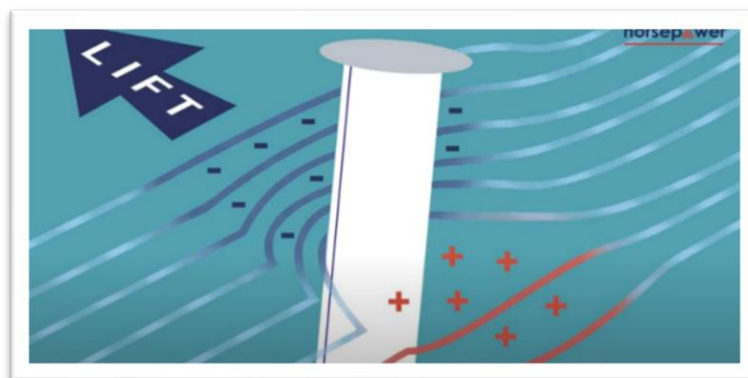
the oceans. Terminators, where the main axis is perpendicular to the direction of wave propagation; and a point-absorber, which is not sensitive to wave pressure due to its small size relative to the wavelength of the incident.



### Rotor Sails:

**Working Principle:** The rotor sail works using the Magnus Effect.

This rotor sail is a rotating cylindrical column and causes pressure differences on the sides of the cylinder, resulting in significant lifting values. The design has proven to be successful, reducing costs and increasing energy efficiency. To compare the efficiency of these rotor sails, they are equivalent to driving a small bus driven by a large lawn mower.

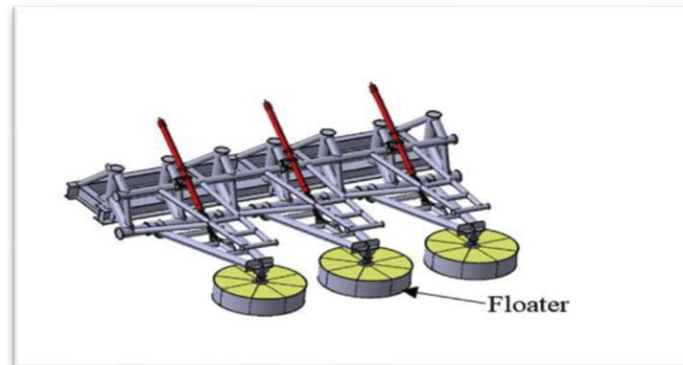


## 2. Main Work:

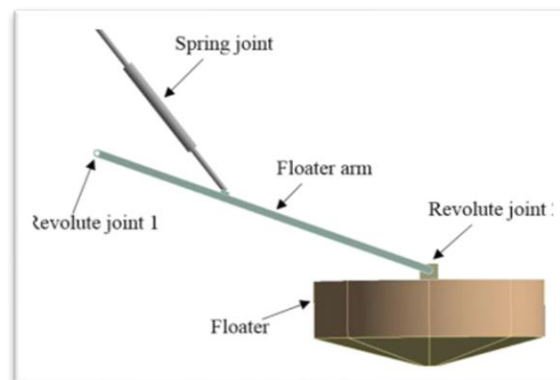
We have concentrated on the concept of Newton's third law that is, energy can neither be created nor be destroyed it can change from one form to another form.

In **Wave Energy Converters** (floaters), We have used pascal law, wave energy conversion using the hydraulic system. The performance of the system is shown to be optimized by both tuning to a desired wave period and impedance-matching. The desired wave period may be either that of the local swell or the period corresponding to the peak of the wave energy spectrum. Air compressibility is shown to be an important factor in the tuning process. By

reducing the air volume above the oscillating water column, the natural period of the system is reduced.



Due to their compact size, the amount of energy that can be produced by WEC holding a single point is small compared to other WEC types. However, this limit can be overcome by using multiple point-absorbers, which include several floating objects. In general structural analysis, material properties, natural loads, model sizes and parameters values are determined. In those systems, the uncertainty in the design parameters should be systematically considered using a stochastic model, down to the practical and advanced design that can take into account the life cycle of the structure and the temporal damage mechanisms. Fidelity analysis provides an effective way to better understand the system response to input parameter changes and thus leads to more reliable designs. In this case, the WEC analysis method is required to model the uncertainty arising from the model problem, its physical properties, load conditions and PTO characteristics.

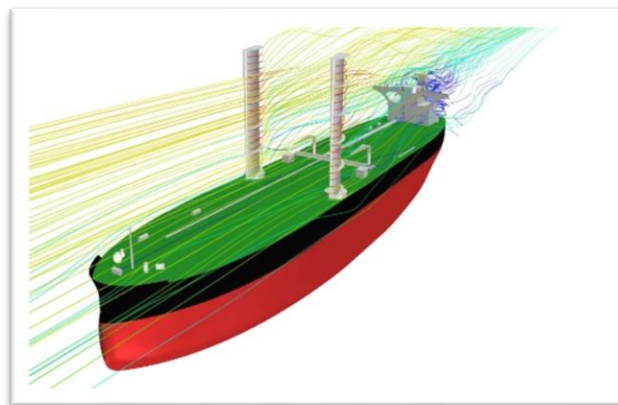


The methods used for modeling the WEC structure can be divided into approximately two groups, namely 1) testing, in which structural responses are measured using sensors such as strain gauges and transport sensors; 2) FEA (Finite Element Analysis), which predicts structural responses based on numerical estimates. The first method allows for direct testing of the structure by measuring the types of assets under consideration and then assessing the related pressures. The test method has the advantage of accuracy as it avoids model uncertainty; however, it is expensive and time consuming when response flexibility, due to design uncertainty of design, should be considered. The second method analyzes system responses with a computer-generated FEA, allowing for the testing of various cases. Due to its high

flexibility and reliability, FEA is widely used in solving complex engineering problems and is widely used in the simulation of renewable energy infrastructure, such as wind turbine composite blades, marine support and marine structures. Therefore, FEA is preferred in this regard. WEC building modeling research. Once the reliability test of the original structure has been performed on a given stochastic set of input, the basis for the development of significant model variables is established. From the initial assessment, it is possible to focus on design components that fall into failure early and make further analysis to promote modification and avoid failure. With the best of the authors' knowledge, the WEC's relieving loyalty points have never been reported in the literature although fidelity has been identified as a major obstacle to the continued development of marine energy technologies. This paper aims to develop a framework for assessing the fidelity of WEC floating points that absorb a point and develop an initial floating design on the basis of fidelity. A point-by-point analysis of WEC-absorbing floating points, which includes a FEA parameter model, response area model and fidelity analysis is being developed.

- **Contraction of Floaters:** While in sea, the contraction of floaters is generally in heavy or stormy weather and while docking the ship also we have to contract the floaters ( using hydraulic system ).
- **Procedure of Contraction:** We use hydraulic system for the contraction and expansion of the floaters. In hydraulic cylinders throughout the machine, fluid is pumped and is subjected to pressure based on resistance. Control valves control the flow directly or automatically and the fluid is distributed through hoses, tubes, or pipes.

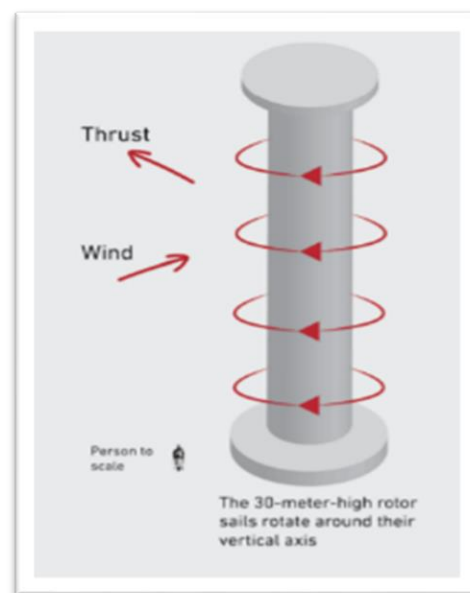
In Rotor sails, wind energy is converted into electrical energy through motor. The Rotor Sail is based on the Magnus effect. When wind meets the spinning Rotor Sail, the air flow accelerates on one side of the Rotor Sail and decelerates on the opposite side of the Rotor Sail.



In 1924, a 2000-ton schooner, called the Buckau, installed two rotor sails 15m long and 3m wide. These two rotors are powered by engines that require 20 horsepower, capable of carrying 1000 wind power. This model has crashed its first system and has managed to perform 130% more efficiently than the original sails. On top of this, the new rotor sails had a fifth weight of the original sail and wrap, the volume of the rotor sails took up a bit of deck, and this led to safer sailing in stormy waters. Rotor rides through the air in the air, allowing this navigation system to "protect the storm."

Flettner rotors have long been forgotten due to the combination of the global economic downturn and falling oil prices. The project was re-evaluated in the 1970/80 oil crisis but did not catch on until the late 2000's. CO2 emissions have been steadily rising over the past few decades and oil prices are rising steadily as well. Exporting heavily depends on ships for freight. About 90% of all international goods are shipped due to low transportation costs and reliable services.

Rotor sails reduce these emissions by an average of 13% per vessel per year: this equates to 1,000 tons of fuel and 3,000 tons of CO2 produced per vessel per year. In 2009, the German wind-turbine manufacturer, built a new rotor ship, the E-Ship 1. This used four rotary sails and was more than 25% more fuel efficient. Of the total fuel savings, 15% can be attributed to the use of rotor sails and the remaining 10% is due to its steam turbine. In addition to geometric measurements and rotor sail sizes, rotor sails are controlled by one parameter: rotational speed. The rotational speed of the rotor sail determines the maximum effect of the amount of lifting power generated. Factors such as wind speed, weather and wind angle affect the use of rotor sails, however they are usually not controllable. Rotor sails work well under a range of these feature features, which makes them well thought out.



Rotor sails take up suitable deck space, but not nearly as much space as regular sails. The length of the cylinder, the endplate and its width usually have a constant aspect ratio: in this study, the aspect ratio of the length to the diameter would be 5: 1. The endplate enhances the coefficient of lift / drag, making it an effective addition to the rotor sails. The aspect ratio of cylinder width versus endplate width is 1: 1.5. These selected components correspond to the experimental studies of the coefficients of lifting and dragging seen in the graph above. The aspect ratio affects many relationships, and these measurements will allow for accurate analysis of the rotor sails.

Magnus Effect is the driving force behind these rotor sails and is the pinnacle of this study. By preparing for the conditions of this situation, rotor sails will achieve powerful results. Magnus Effects explains how the interaction between fluids can enhance energy in an environment. In

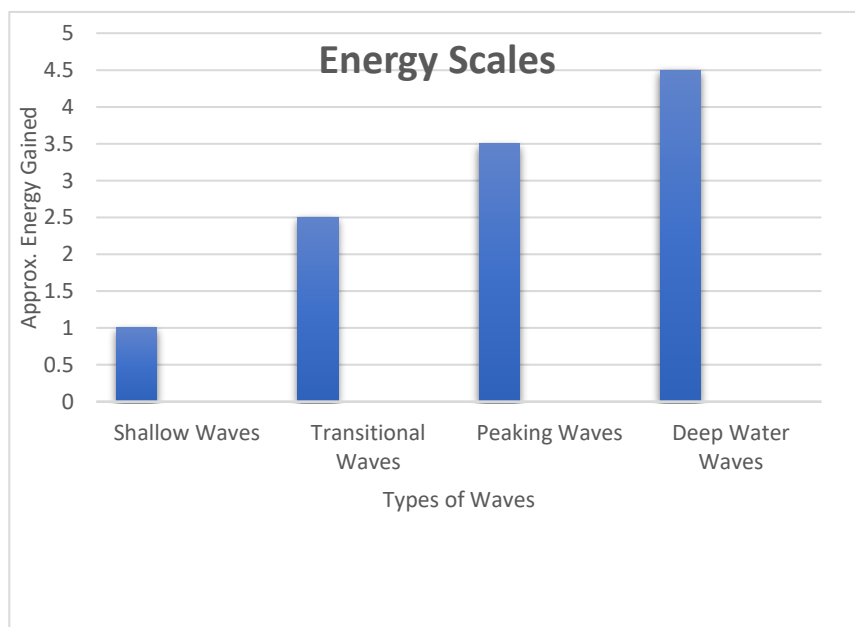
the case of rotor sails, a good air source can move along the cylinder - either a star board or a hole. The angle at which the wind blows is irrelevant, and it can affect the direction of elevation by 180 degrees. Fortunately, there is a simple solution to keep the lift forward: it depends on the rotating direction of the cylinder. When the air flows at a 0-degree angle, the rotor sails should rotate clockwise to maintain the lifting force. Similarly, when air flows at a 180-degree angle, the rotor sails should rotate opposite the clock to gain increasing lifting force.

### 3. Conclusion:

An overview of the most important parameters involved in constructing WECs to absorb the floating floors exposed. The wave energy source has different regions and periods, and higher energy is found mostly in deep water. The source of energy found in a particular area should be considered at all times of the year. This data may be represented in the energy spectrum that provides for the distribution of wave energy in that area.

Wave properties can be used as a basis for completing the size or geometry of the WEC. Wavelength, time, and water depth data are most found in wave gauges. This can be used to calculate wavelengths using appropriate wave theory, keeping in mind the limitations of wave perceptions. The wavelength used to calculate wave characteristics varies from depth to depth.

PTO systems are different in different WECs, categorized primarily as a straightforward driving system and buffer systems. In direct driving systems, the moving part of the generator is directly connected to the mobile part of the WEC. In a buffer system, the wave energy is first absorbed by the main medium, and then transferred to a generator. Due to the unusual nature of the waves, the outflow of power will vary greatly and thus it will be difficult to set it to suit the requirements of large power grids.



This Rotor sail model has been practically tested by Maersk Shipping as they have installed Rotor sails on their ships. We are trying a hybrid model which can save energy and reduce the maintenance cost.

WEC's are generally used near dams, but we are trying to use this source of energy on board ships.

### References:

1. Bozzi, S., Miquel, A.M., Antonini, A., Passoni, G., Archetti, R., 2013. Modeling of a point absorber for energy conversion in Italian seas. *Energies* 6 (6), 3033-3051.
2. <https://en.wikipedia.org/w/index.php?search=pascal+law&title=Special%3ASearch&fulltext=Search&ns0=1>
3. [https://en.wikipedia.org/wiki/Newton%27s\\_laws\\_of\\_motion](https://en.wikipedia.org/wiki/Newton%27s_laws_of_motion)
4. Lehmann, M., Karimpour, F., Goudey, C.A., Jacobson, P.T., Alam, M.-R., 2017. Ocean wave energy in the United States: current status and future perspectives. *Renew. Sustain. Energy Rev.* 74, 1300-1313. ISSN: 1364-0321. <https://doi.org/10.1016/j.ner.2016.11.101>.
5. Pearson, D R. "The Use of Flettner Rotors In Efficient Ship Design." Influence of EEDI on Ship Design, 2014, [www.researchgate.net/profile/David\\_Pearson36/publication/287081987\\_The\\_use\\_of\\_Flettner\\_rotors\\_in\\_efficient\\_ship\\_design/links/5b28b8c7aca2727335b719a4/The-use-of-Flettner-rotors-in-efficient-ship-design.pdf](http://www.researchgate.net/profile/David_Pearson36/publication/287081987_The_use_of_Flettner_rotors_in_efficient_ship_design/links/5b28b8c7aca2727335b719a4/The-use-of-Flettner-rotors-in-efficient-ship-design.pdf).
6. Norsepower. "Norsepower Unveils First Tilttable Rotor Sail Installation with Sea-Cargo Agreement - Norsepower Rotor Sails." Norsepower Introduces New Tilting Rotor Sail Technology with Sea Cargo, Norsepower, 29 June 2020, [www.norsepower.com/post/norsepower-unveils-first-tiltable-rotor-sail-installation-with-sea-cargo/](http://www.norsepower.com/post/norsepower-unveils-first-tiltable-rotor-sail-installation-with-sea-cargo/).

# ECO FRIENDLY SHIPPING THROUGH NANOTECHNOLOGY

Cadet Chitranjan ,Kumar<sup>a</sup>, Cadet Chittharanjan B A<sup>b</sup>, Cadet Mainak Paul<sup>c</sup>

<sup>a</sup>IMU Chennai,chitranjan005kumar@gmail.com

<sup>b</sup>IMU Chennai,chitthuba02@gmail.com

<sup>c</sup>IMU Chennai,mainak14.paul@gmail.com

## Abstract:

This Technical Project aims to reduce NO<sub>x</sub>, SO<sub>x</sub> and PM pollution by a huge margin, since we plan to use a locally prepared stabilized fuel which will be much more efficient. This Fuel is prepared by smashing water and diesel in a condition of high velocity and pressure thus increasing the surface area further leading to higher rate of combustion and increased efficiency. This will not only cut down on pollutions but also on the operational costs in a long run.

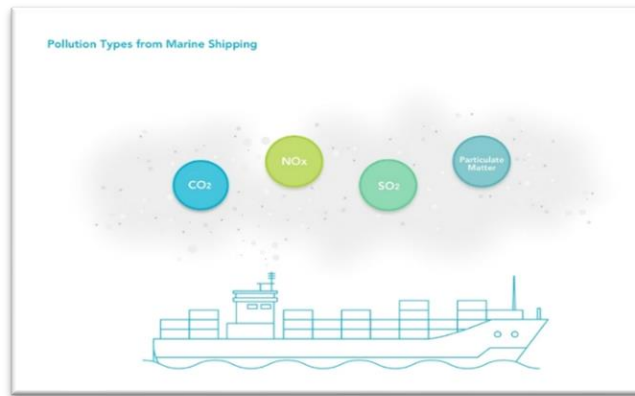


The overall reduction in these harmful gasses will impact our nature in a very positive way. We feel this the way forward for us, Human. We need to move in a direction where we cut down the the exploitations that we do on nature as this in return will improve the quality of our living and opens door to a brighter tomorrow with much better, smarter and cleaner technologies.

## Introduction:

Almost all ships afloat around the world run on fossil fuels, and contribute up to 18% to 30% of the world's nitrogen oxide pollution, and around 10% of the world's Sulphur oxide pollution. Shipping emissions represent about 13% of the EU greenhouse gas emissions. It also accounts for the 90% of worlds PM (Particulate Matter) pollution.

In this technical report we will discuss why our technology is crucial for the future of efficient and clean shipping. And most importantly why is this a technological marvel and why should a company or a investor invest his resources in this Project.



### Current environmental issues in Maritime field

International shipping emissions increased by 1.4%; domestic shipping emissions increased by 6.8%; and fishing emissions increased by 17%.

#### ***NO<sub>x</sub> Emissions:***

Ships are responsible for 15% Percent of the Global NO<sub>x</sub> Pollution and up to 12% of the total NO<sub>x</sub> pollution in port cities. These are the average figures collected all over the world.

#### ***SO<sub>2</sub> Emissions:***

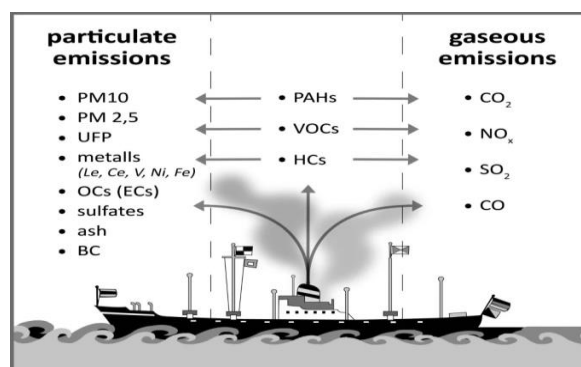
Shipping industry accounts for the 9% of the global SO<sub>2</sub> emissions and up to 3% of the total SO<sub>2</sub> pollution in port cities.

#### ***PM (Particulate Matter) Pollution:***

It was estimated that the direct contribution from shipping in the Bay of Algeciras PM<sub>10</sub> was 1.4 to 2.6 µg/m<sup>3</sup> (3-7%) and PM<sub>2.5</sub> concentration was 1.2 to 2.3 µg/m<sup>3</sup> (5-10%). The study demonstrated further, that the total contribution from shipping reached 4.7 µg/m<sup>3</sup> (13%) for PM<sub>10</sub> and 4.1 µg/m<sup>3</sup> (17%) for PM<sub>2.5</sub>. Shipping Industry accounts for 64% pollution in and around a port city.

#### ***CO<sub>2</sub> Emissions:***

In 2015, total shipping emissions were responsible for 2.6% of global CO<sub>2</sub> emissions from fossil fuel use and industrial processes. International shipping contributed the most, representing about 87% of total CO<sub>2</sub> emissions from ships each year. If treated as a country, international shipping would have been the sixth largest emitter of energy-related CO<sub>2</sub>. Ships contributed 2.2% of the world's total CO<sub>2</sub> emissions. Shipping CO<sub>2</sub> emissions increased from 910 million tonnes to 932 million tonnes in recent years.



### **Aim of Our Project:**

The Project that we are proposing is aimed at cutting down NO<sub>x</sub> and PM pollutions drastically. We can accomplish this project through the science of Nano technology.

### **Detailed Technical Report:**

In the current shipping industry, most of the M/V vessels run on diesel IC engines. These engines use heavy or bunker fuel. But we propose to change this practise. We have found out a new variant of diesel for better efficiency and a cleaner exhaust.



For this we have to mix diesel with water. Yes, you read it right, this is as simple as it looks. But there arises a problem here. Naturally water and an oil does not mix well together, as we know diesel is an oil too. We all know that mixing oil and water results in an emulsion, this is because of the difference in their nature (polar and non- polar), as the molecules of these two don't like to stick with each other for a long duration of time. This results in the fuel not getting ignited properly, thus resulting in uneven working of the IC engine. It will also leave behind a particular of water inside the chamber of the engine which is a nightmare of any marine engineer.

So, our idea is to smash water and diesel molecules at a very high speed under very high pressure. These physical changes made while mixing the two molecules results in a semi stable emulsion state, in which these two molecules do not separate easily. To completely stabilize this mixture, we need to add an additive which helps to convert this emulsion into a fully functional stable fuel.

The technical mechanism here is to jet out both the liquids toward each other in a closed chamber to attain the maximum velocity and a pressuriser is used to maintain very high pressure while the collision is being taken place. This mechanism will be installed on the ships as we can desalinise and distil the sea water locally so that we only have to carry diesel on board. This semi stable emulsion fuel is completely stabilised by using an additive stabilizer which is mainly a methanol-based hydrocarbon fuel. More research has to be done in this field too for better performance.

When this fuel is injected in the combustion chamber of an IC engine, we tend to get more efficiency per litre of diesel used. The ratio in which we mix these two fluids is around 80-20 ratio. This ratio is still under further research, so the final ratio will depend on the further efficiency results. This injected hybrid fuel will further get combusted to deliver more torque to the shaft.



### Why does this work?

This is where the role of nanotechnology and physical chemistry comes in hand. When we smash the two different molecules of water and diesel at such high velocity and high pressure, the resulting mixture when observed under microscope, clearly shows us that the overall surface area of this mixture has increased in a drastic manner. This happens due to the diminishing size in the particles. This enhances the combustion further more of the same fuel previously used now to the fact of increased surface area of this hybrid fuel as surface area of the fuel is directly proportional to higher combustion rate and thus better efficiency.



### Why should we adopt this technology?

- This formulae or process of fuel making via nano technology will cut down NOx emissions by 50%, and PM (Particulate Matter) Pollution by 90% according to our estimates.
- These amounts of reductions in emission is very critical for a cleaner, better and a eco-friendly shipping industry for our better future.
- Yes, this requires some investment for its research and development and also costs a bit for implementation of this technologies in existing ships, it is proven to reduce the costs over a long period of time as the overall efficiency per litre of diesel will be increased by approximately 30%.
- Since the fuel mixture is made on the ship, it will be cost effective than making it on land as local making of this hybrid fuel will be in higher quantities, could be made instantly and the local sea water can be distilled and used.
- The combustion of this fuel will reduce the temperature of the engine by around 25% thus avoiding a lot of mis happenings.

## Why should we invest?

- Shipping industry is under a high pressure to go green and clean, and a lot of further scrutinise will be put on the marine sector to cut down the emissions and reach the global carbon reduction goals by 2050 (and 2075 for India). To abide by those goals set, marine sector will have to undergo further improvements to reach the desired emission goals.
- Implying this technology, less resources will be used to decrease the heat produced in the overall propulsion systems of the ship.
- On top of this, saline water can be distilled on board and so indirectly we are getting more fuel for the ship, as we are carrying diesel already and water is available as well. Which means more efficiency than too carrying the existing fuel on ship, thus reducing the operational costs.
- This technology will not force the ship to go complete design change and needs few systems to be installed on board for this hybrid fuel making procedure, thus will not cost high amounts of investments which would have required for complete transformations.
- Since the overall efficiency is increased, the operation charges again go down.



- This technology would attract a lot shipping company's attention; thus, the investors will heavily profit out of this as it will be under high demand.
- Since this technology focuses on cutting down on pollution, this will align with the aim of GREEN SHIPPING and thus will cut down the current fines bared by shipping companies for their air pollution and can also avoids particular sanctions and restriction.
- Coming early in the game increases the success percentage, installing this technology sooner will give upper hand with the ongoing trend of go cleaner, thus will giving profits in the terms of reputation and capital.

## Approximate Cost:

This is always a big question for any of the investors or businessmen who would like to invest in this project. We have calculated an approximate figure in Indian Rupees. But there is good news at the end. For the initial research and development of this technology and mechanism it would cost around Twenty Crores (approximate figure), and for implementation of this technology and mechanism in the ships it would cost anywhere from one crore to seven crores based on the size and complexity of the ship. But the best part of it is that, the operational and running cost over a long term is amazingly lesser than the conventional methods we use today. The costs of operation and running would be cut down up to an approximate figure of 30 percent. This is a huge figure when it comes to long term operations of the ship as the money saved at long term is far more than the initial investments. This is amazing news for all of us.

### Author's Note:

This is going to be a revolutionary technology as it solves one for the greatest problems to nature by shipping that is extreme air pollution. The overall reduction in these harmful gasses will impact our nature in a very positive way. We feel this the wayforward for us, Human.



We need to move in a direction where we cut down the the exploitations that we do on nature as this in return will improve the quality of our living and opens door to a brighter tomorrow with much better, smarter and cleaner technologies. Thus, according to us, this is a golden idea and we need to immediately start working on it further with as much help and support for a better shipping future and better tomorrow.

### References:

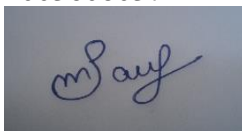
1. <https://www.wikipedia.org/>
2. <https://www.marineinsight.com/>
3. <https://www.wartsila.com/encyclopedia/term/exhaust-gas-emissions-from-ships>
4. <https://www.imo.org/en/MediaCentre/HotTopics/Pages/Reducing-greenhouse-gas-emissions-from-ships.aspx>

### Authors of the report

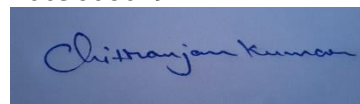
Cadet Chittharanjan B A  
chitthuba02@gmail.com  
+91 8197976911  
2003608020



Cadet Mainak Paul  
(WILL BE PRESENTATING)  
mainak14.paul@gmail.com  
+91 9783760336  
2003608037



Cadet Chitranjan Kumar  
chitranjan005kumar@gmail.com  
+91 6202620677  
2003608019



# SMART FIRE EXTINGUISHING DEVICE (SFED)

Cadet Aakash Chauhan<sup>a</sup>, Cadet Rahul Dutta<sup>b</sup>, Cadet Rakshit Mishra<sup>c</sup>

<sup>a</sup>The Great Eastern institute of maritime studies, caakash9212@gmail.com

<sup>b</sup>The Great Eastern institute of maritime studies, dutta648600@gmail.com

<sup>c</sup>The Great Eastern institute of maritime studies, rakshitblaze97@gmail.com

## Abstract:

Many fire based mishaps are happening these days which involves huge misfortunes of lives as well as property. The principle problem in fireplace prevention, fire-preventing and protection on board ship is that of understanding the 'enemy', i.e. Fire, and the environment in which it thrives. This calls for the only hand technological approach of decreasing it to an absolute minimum and the opportunity of fireplace breaking out and proscribing its capability to spread, so that there may be automated intervention, and on the alternative right training of fire-fighting and fireplace-prevention squads. Moving on with non-conventional way i.e. Smart fire extinguishing device of firefighting will not only be advantageous but will be enhance the safety and durability of the resources as it does not involves the physical involvement of the Firefighter and is able to extinguish the fire with absolute accuracy.

## 1. Introduction:

### 1.1 Vision

At the most significant level, the general objective for Fire Fighting is to eliminate undesirable fire and other hurtful occasions as a constraint to life security, specialized development, and monetary success. The vision to further develop firefighting method which involves

- To save lives and limit wounds to building inhabitants and local area individuals because of Fire.
- To further develop firefighting method i.e. related to wellbeing and security of person
- To upgrade the functional productivity of the fire administration and the viability of fire Assurance
- To limit property misfortune from fire.
- To limit business interference and loss of mission coherence because of fire.

### 1.2 Objective

- The objective of this smart firefighting ball is to extinguish the hazardous fire which takes place on ships without carrying a heavy extinguish bottle or hoses to the accidental place.
- Reduce the weight of extinguishing equipment present on ships.
- Reducing the space carrying capacity.
- And making the extinguishing process simpler.

### 1.3 Concept

Fire extinguishing ball is a sphere-shaped device made up of foam casing enclosed in PVC filled with environmentally friendly non-toxic chemical powders. An activation strip inserted into the outer casing which holds the fire suppressants. The extinguishing ball is filled with a dry powder fire extinguishing agents like mono ammonium phosphate. The ball self-activates within at least 3 seconds of contact with the fire; explodes and releases the extinguishing agents. These extinguishing balls are effective in a detached and dynamic way that is, mounted on the wall as well as tossed into the flames.

## **2. Main Work:**

### **2.1 Working Principle**

The Firefighting extinguish ball is an explosive/ grenade type extinguishing ball. These balls can be used for both purposes like dry fire as well as wet fire. As the chances of wet fire on board are high. So instead of using different extinguishing devices for various conditions at that critical moment is quite hard.

This firefighting ball works on the principle of blast Wave.

A Blast Wave consists of a sudden kinetic energy release in the surrounding area. Now the product firefighting ball also works on the same principle but the only difference is that during this explosion the debris which are released during this shock wave are not harmful and in the limits of human safety.

The basic concept of any explosive contains a frangible material with an abrasion resistant, exterior sheathing. And for the interior part of the internal cavity comprises a low explosive yield detonator near the centre of mass and carried out with a fuse cord extending from the detonator to the exterior surface.

The hollow casing is chargeable through variation in internal configuration of chemical agents.

So the main concept of firefighting ball its works on the principle of Shock wave. As the interior part of the ball is a chargeable component consisting of various chemical agents resistant to any type of fire. The exterior part or covering consist of a frangible material which activates within 3-10 seconds after coming in contact with fire. Means the fragile material will burn out within 3-10 sec. After coming in contact with fire, the interior material which is already charged will explode in a similar way as a shock wave by extinguishing the fire near it.

These balls are easy to use as compared to the old extinguishing methods. The only thing needed to do is keep these balls in a ball stand near the or above the places where the chances of fire accidents are high or throw them on a fire accidental zone from a safe distance.

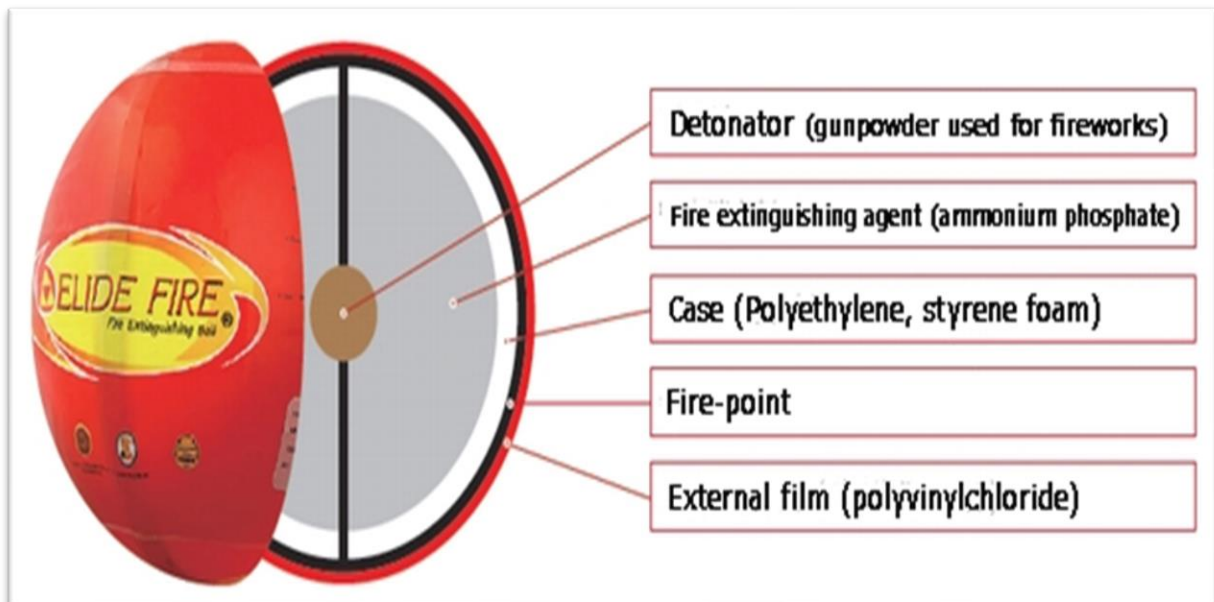
The weight of these balls are hardly near to 1.3-1.5 kg which is way to less as compared to the fire extinguishing cylinders. And the main point is that it activates automatically during fire.

And this automatic activation doesn't depend upon any electronic or mechanical sensor, this factor makes this product more reliable and easier to use.

### **2.2 Detailed Diagram: -**



**Fig. 2: - Descriptive Figure of Fire Extinguishing Ball**



**Fig. 3: - Section View of Fire Extinguishing Ball**

**2.3 Comparison: -**

| <b>Issues</b>                 | <b>Fire Extinguishing Ball</b>   | <b>Existing Fire Extinguisher</b>   |
|-------------------------------|--|---|
| <b>Weight</b>                 | 1.3KG (Light & Portable)   | Usually bulky/Heavy weight  |
| <b>Packaging</b>              | Spherical  | Cylindrical   |
| <b>Fitment</b>                | Can be fitter anywhere, ceiling, wall, inside the panel etc. thus making it suitable for all application                                     | Wall mounting/Movable   |
| <b>Usage</b>                  | Both manual and auto spray   | Only Manual Spray   |
| <b>Manual Usage</b>           | Can be easily used manually, even by small children, old aged and physically handicapped people  | Can be used manually by trained people only   |
| <b>Operation</b>              | Only after Flame touch at 85 Deg. C  | Only 10% people trained to use it Manually  |
| <b>Direction</b>              | Chemical spreads in 360 Deg. Uniformly, thus extinguishing the fire of a bigger area at one shot.  | Can be sprayed at one point only at a time.   |
| <b>Refilling</b>              | No Refilling Required – Self Life of 5 years   | Required Annually   |
| <b>Discharge Distance</b>     | No Distance restriction- It can be tossed from safe distance with Auto Activated Provision. A single ball can cover area of 9.12 cubic meter | 2 metre Straight. A 5kg cylinder gets evacuated within 18-20 sec – Hence no scope of area coverage. |
| <b>Environmental Concerns</b> | If is free of CFC as made from Mono Ammonium Phosphate Dry Powder –which are Nontoxic and Eco – friendly                                     | Most are made from CFC & other materials which are of Toxic Nature                                  |
| <b>After Affects</b>          | Doesn't Damage nearby properties   | Causes damage to nearby properties  |



**Fig. 4: - Comparison of equipment's**

## 2.4 Case Study:

### i) Incident:

A bulk carrier was on voyage between 2 ports in Europe. During her passage, vessel's crew was operating cleaning procedures in Cargo holds and A/E No.1 and No.2 were on parallel function as the ship was needed a larger electrical load than it usually requires.

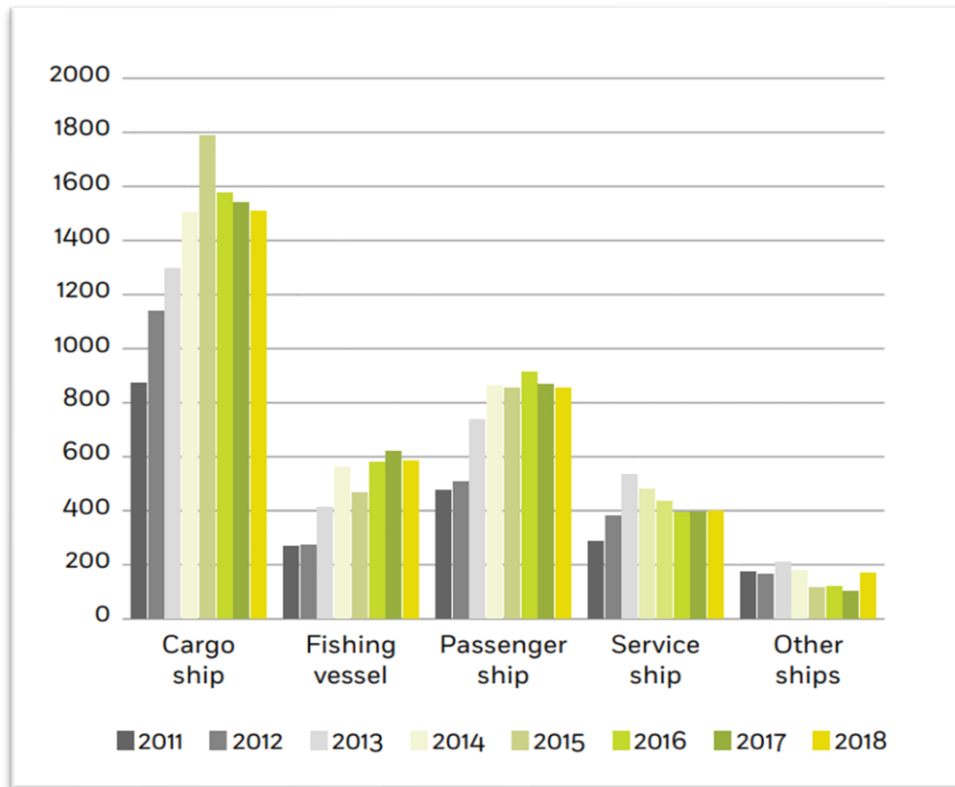
Engine crew was carrying out a renewal of lube oil filters, while engine officers were participating in a safety meeting conducted at the engine control room. As a result, engine ratings had been carrying out their tasks without the supervision of engineer officers.

Suddenly, engine ratings observed flames between the two running generators. Fire alarm sounded in order to inform the rest crew members.

Officers communicated with the bridge to make sure that they can stop engines, then they tripped the main supply bakers on the switch board and the emergency generator came on load. In a few minutes, the engine room had been covered with black smoke and it was difficult for the crew to breathe or see clearly, thus they evacuated machinery space immediately. Aiming to isolate the engine room in order not to let the fire spread, the crew operated the ventilation trips, flaps and the quick closing valves.

### ii) Actions taken to extinguish the fire in this situation:

Subsequently, on board fire team entered the engine space totally equipped, wearing self-contained breathing apparatus (SCBA) and with portable and semi-portable extinguishers, managed to fully extinguish the fire. For a few hours, they continued to check machinery space for portable fire outbreaks, and by the time they ensured safety, they re-entered the room. Appropriate safety checks concerning the continuance of operations had been taking place to set A/E No. 3, the main engine and other machinery in operation mode, in order to Resume passage.



**Fig. 1:** - Marine casualties and incident

**iii) Causes:**

- a. On A/E No. 2, one of the three bolts that secure lubricating oil filter had displaced the cover, leading the lube oil to splash onto various hot components on both generators, which finally ignited.
- b. All the lube oil had been spilled in the tank of the A/E No. 2, because lube oil primer Pumps had continued to operate after engine’s shutdown, gathering power by emergency power source. A/E No. 2 was the main source which fed the fire.
- c. It is common filter cover bolts to be too wear or too loose as a result of continuous Vibration or due to the internal pressure from pumps. That fact makes the regular Inspection routines a necessity, as in this case these fittings were improperly tightened and engine room supervision was inadequate.
- d. It was also observed that the cover bolts used on lube oil pipes and filters on A/E were not properly manufactured with the full absence of extra securing arrangements or spray shields.

**3. Conclusion:**

After concluding all the above data, if the shipping industry accept this new fire extinguishing method it will a revolutionary change for firefighting methods which are used currently and for the seafarers and the vessels. It will easy to use and more quantity can be stored in compact places also. Even the reacting and the extinguishing time is much more effective than the sensor-based sprinkler and extinguishing cylinder.

## **Acknowledgments:**

Thanks to our Principal, Capt. A. P. Sethi, Vice Principal Capt. Philip John, our course in charge, Mr. Narendra Katdhare, Mr. Satish Chandra Upadhyay, Mr. Sudhanshu Phalke, Mr. Milind Kulkarni, IT instructor, and all Faculty, in providing their valuable time in the compilation of this paper.

Thanks to Mrs. Meena Ravi Shankar, soft skills trainer, for the untiring support and assistance given while preparing our paper.

We are equally grateful to 'TRANSTECH 2022', to have given us this opportunity to present our technical ideas on our chosen topic, effectively & efficiently.

## **References:**

1. <https://safety4sea.com/23073-maritime-casualties-and-incidents-reported-in-2019/>
2. <http://entirelysafe.com/fire-ball-extinguisher/#.YhH98ehBxPY>
3. <https://tnku.jp/en/2019/02/15/3202/>
4. <https://qatar.desertcart.com/products/62786213-elide-fire-extinguishing-ball>
5. <https://hpforest.nic.in/files/Merged-20161108-144411.pdf>
6. [https://www.researchgate.net/publication/341266260\\_Development\\_of\\_an\\_Innovative\\_Fireball\\_Fire\\_Extinguishing\\_System](https://www.researchgate.net/publication/341266260_Development_of_an_Innovative_Fireball_Fire_Extinguishing_System)
7. <https://www.elidefire.com/>

# BLACK CARBON AS A FORM OF GREEN HOUSE GAS

Cdt. Karan Rautela, Cdt<sup>a</sup>. Manpreet Singh<sup>b</sup>, Cdt. Manav Gurjar<sup>c</sup>, Cdt. Om Dhamdhare<sup>d</sup>

Tolani Maritime Institute, Pune

## Abstract:

All living things that live on this earth come under the environment. The environment is a nature that nurtures our life on the planet. Everything we feel, breathe, and eat in our lives comes from the environment. The existence of our healthy life depends on the environment, which maintains natural equilibrium, without which it will lead to catastrophic disasters. Many leading organizations like IMO have implemented new rules and protocols to keep harmful human activity at bay to prevent these forsaken cataclysmic scenarios. In support of the UN sustainable development goal 13 to take urgent actions to combat climate change and harmful impacts of dangerous contaminants like BLACK CARBON. This paper introduces the adverse effects of black carbon, sources, and control measures.

**Keywords-**Black Carbon, HFO

## 1. Introduction

As we know, these merchant ships consume heavy amount of fuels, so this fuel emits heavy pollutants such as SO<sub>x</sub>, NO<sub>x</sub>, N<sub>2</sub>O, Black Carbon. As IMO Has Primarily Considered SO<sub>x</sub>, NO<sub>x</sub>, N<sub>2</sub>O As Major Pollutant But IMO Has Neglected Another Leading Pollutant Termed As Black Carbon. So In Our Project, We Have Highlighted The Black Carbon Impacts, Quantity Of Emission By Certain Ships, And Its Control Measures. Black Carbon Are Produced By Ships Burning Heavy Fuel Oil It Accounts For 21% Of CO<sub>2</sub> Emission, Making It The second most crucial driver of shipping climate impacts after carbon dioxide. In Our REPORT, We found that ships emitted an estimated 67 thousand tonnes of black carbon in 2014, representing more than 20 percent of CO<sub>2</sub> Equivalent emission from ships on a 20-year square, making black carbon an essential contributor to the sector's climate, warming, impacts. We Have Combined These emission Factors with the state of scientific-terrestrial and satellite automatic identification system From HIS Fairplay. We Have analyzed the potential effectiveness of several black carbon control measures, including switching to cleaner-burning fuels and using diesel particulates filters DPFs

## 2. Chemical Composition for Formation of Black Carbon

Black carbon is formed when the fossil fuels are burnt, and there is incomplete combustion of fossil fuels, woods, and other fuels, and the remaining fuels which are completely combusted turn into CO<sub>2</sub>, but the combustion is never completed due to which various gases like CO<sub>2</sub>, carbon monoxide, volatile organic compounds, organic carbon and black carbon are formed in the process affecting the climate studiously. The resulting matter from incomplete combustion of the complex mixture is called soot. Even if the black carbon has a low life in the environment, the effect of black carbon results in various severe impacts on the climate within the short life like on the cryosphere, agriculture, climate, and mainly on human health and animals.

## Chemical Equation for Black Carbon

As we all know, black carbon is formed when there is incomplete combustion of various fuels, woods, etc., but for reference, there are some equations:

### 3. Black Carbon Is a Primary Pollutant

With this reference to the question, even if we start reducing the emission of black carbon from its sources, the effect on the environment might come to some low extent, leading the health risk from the pollution being affected by the black carbon will reduce. If we look into many organizations are taking various steps to help get the emission of carbon in the air to low like IMO they have introduced various tiers system within shipping side to reduce the effect as ships are one of the sources for the emission of the black carbon.

Black carbon is produced when biofuels (with low Sulphur levels and low co2 emissions) are burnt within 1320 to 1540°C.

### 4. Black Carbon Impacts

#### Climate Impacts:

Black carbon is very effective at absorbing light and heating the surroundings as the 1 unit of black carbon has a warming impact on climate that is 460-1500, which is much stronger than co2(it is affecting the environment less than co2 because of its life expectancy but in its life period it impacts the nature a lot).

Due to its warming effect when suspended in the atmosphere, it influences the cloud formation in its surroundings and impacts its regional circulation and rainfall patterns as black carbon is converting the incoming solar radiation to heat.

The arctic and the Himalayas are slowly getting melted because of black carbon because the ice, which was good at reflecting the sunlight, are not able to do so now because of the reduction of surface albedo, making the surrounding to get heat up and get started melting.

Health impacts

| AIR QUALITY INDEX VS. AIR POLLUTION INDEX |                           |  |
|---|---------------------------|--|
| US ENVIRONMENTAL PROTECTION AGENCY (EPA)  | Pollution index (AQI/API) | CHINA'S MINISTRY OF ENVIRONMENTAL PROTECTION (MEP) |
| Good                                      | 0-50                      | Excellent  |
| Moderate                                  | 51-100                    | Good   |
| Unhealthy for sensitive groups            | 101-150                   | Slightly polluted                                  |
| Unhealthy                                 | 151-200                   | Lightly polluted                                   |
| Very Unhealthy                            | 201-250                   | Moderately polluted                                |
| Very Unhealthy                            | 251-300                   | Heavily polluted                                   |
| Hazardous                                 | 301-500                   | Severely polluted                                  |

How does the US Embassy's pollution index differ from Beijing's?  
 The American index focuses on health (201 is deemed "Very Unhealthy"), while the Chinese ranking relates the numbers solely to pollution levels (201 is classified as "Moderately Polluted").  
 Moreover, due to the varying data used to calculate the respective index numbers (i.e. the US data include PM2.5 as well as PM10 readings whereas China does not track PM2.5), the same day may be reported simultaneously as "Hazardous" by the US Embassy Twitter feed (@beijingair) and "Lightly Polluted" by the Beijing Environmental Protection Bureau.

Chart for Air Quality

The PM2.5 particles are the critical components of delicate particulate matter of black carbon being emitted into the air causing the environmental cause of poor health and premature deaths.

The size of this matter 25 is so much tiny even we cannot see from our naked eyes are being penetrated our lungs deeply and making our bloodstream toxic which is leading to many health problems and due to which the newborn baby or the older people are getting effected and causing the lungs related issue and breath shortened.

This PM2.5 which is much smaller than a grain of table salt, affects the number of health, leading to the premature death of young ones or adults with the disease of bronchitis, aggravated asthma, and other cardiorespiratory symptoms to heart and lung disease within adults. The children born get the disease pneumonia which is an acute disease for lower respiratory infections. If we start counting the deaths, which is getting around 7 million each year, signs of premature deaths attributes to household and ambient PM2.5 air pollution.

### **Effects**

Black carbon in arctic .The black carbon affecting the arctic is not directly emitted there; they are transported via air or weather systems, leading to cloud interaction, making the cooling impact around surroundings. Black carbon is a complex process when the particles that are transported start absorbing the solar energy, making the surroundings warmer when showing their presence in its air.

Due to the effects of black carbon, the conditions in the Canadian arctic have snow-covered landscapes and expansive sea ice. Due to the emission of black carbon particles that settle on the ice making the ice lose its albedo, or we can say making the ice lose its reflecting power making the ice much warmer than any other in the globe at a speed of twice. It also makes the ice change its color.

The warming process in its is very affecting as the black carbon is scattered all over the ice and making the surroundings as well as the ice warmer by absorbing the radiant solar energy, which is making the pace of melting ice increase while the direct warming is making the ice to melt exposing the dark water which absorbed the sun and used as heat to melt making the ice to melt much faster.

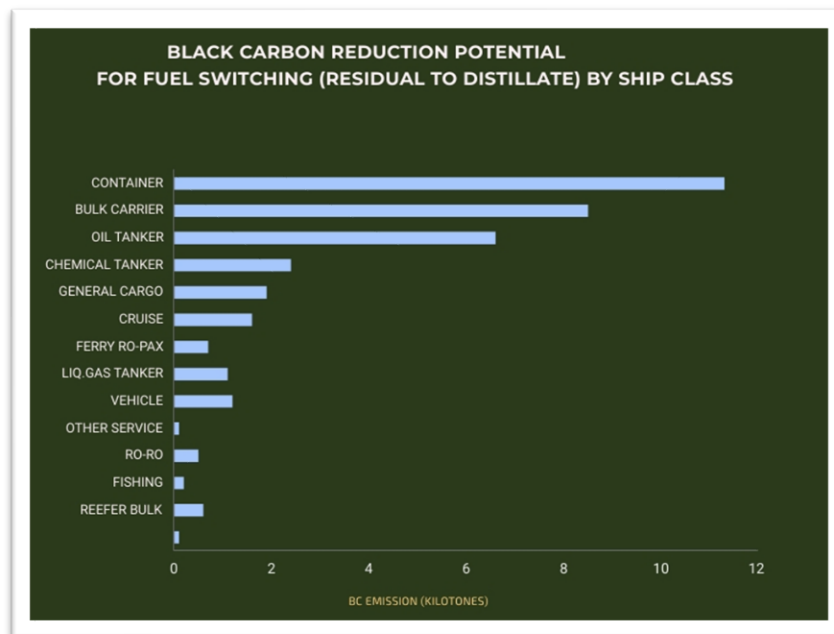
The ships that are operated close to glaciers snow-covered coasts are emitting much black carbon making the ice, such as arctic are making the ice lose its cooling power as the emitted black carbon is overpowering them. The Arctic is losing its cooling power much faster than any other ice in the world.

Effects are rising due to the melting of ice.



Black Carbon in Artic Ice beds

As we have already seen that black carbon makes the ice melt more quickly, making the job of sailors, or we can say making the sailing much harder than any other situation as the warming had made the change in weather and climate have created sea more volatile resulting in increased risk in ships and due to which the ships which are sailing due to sudden change have made the sailing delay. Even many people came with the idea of making the ship much more vital so that it can freely pass by icebreaker for safety, and many have thought of moving the ships slower on ice so that less fuel is burnt, but slow means more of the resistance being faced by the ships resulting in burning of fuel much more than moving fast. Factors that are impacting the travel time of ships are ice thickness, concentration, drift speed, and direction are some impacts. Even we stay at some point in sea standing still waiting for the artic to get in good weather and proceed but while waiting there means more fuel is being burnt and making the emission of black carbon more and more than moving ship.



Emission of Black Carbon Due to change in Fuel

If we look into the traffic on the arctic side, it is more congested, making the navigational site busier, the navigational challenges posed by a lack of infrastructure, and changing weather and ice conditions. The fuel used by the ship is supplied counted with the route, but due to the arctic, the future fuel consumption and emission are challenging to predict, making it much worse while challenging to mitigate. According to the research, the scientist predicts that the emission will be much worse by 2030 as the shipping traffic is holding about five percent of black carbon emission.

If this matter is not resolved shortly, it will make the ocean and shipping a vast impact will lead the world in greenhouse effect much worse.

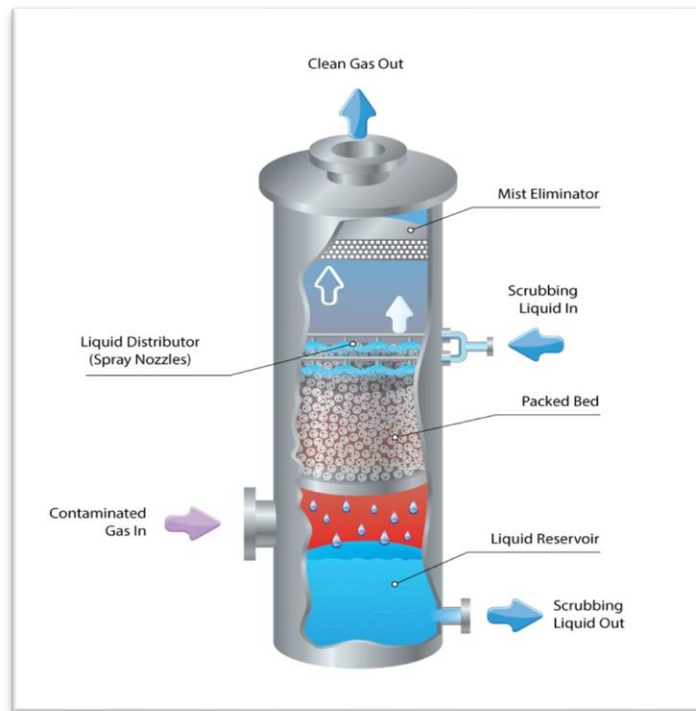
## 5. Control Technologies

Many organizations have shown up with different studies and different technologies and operational practices that can be used to reduce the impact and emission of black carbon from the ships.

Some of them are listed below:

- **Exhaust Gas Cleaning Systems**

Many ships have introduced this system where these exhaust gas cleaning systems such as scrubbers can reduce the emission of black carbon as these scrubbers can reduce the emission by roughly 30 percent. Ships like cruise ships that use such heavy machines to run heavy ships carrying many people have installed scrubbers to comply with ECA to meet the standard emission of sulfur. At the same time, other ships have been notified to comply with the new 2020 sulfur standard 0.5 fuel and install the scrubbers as early as possible.



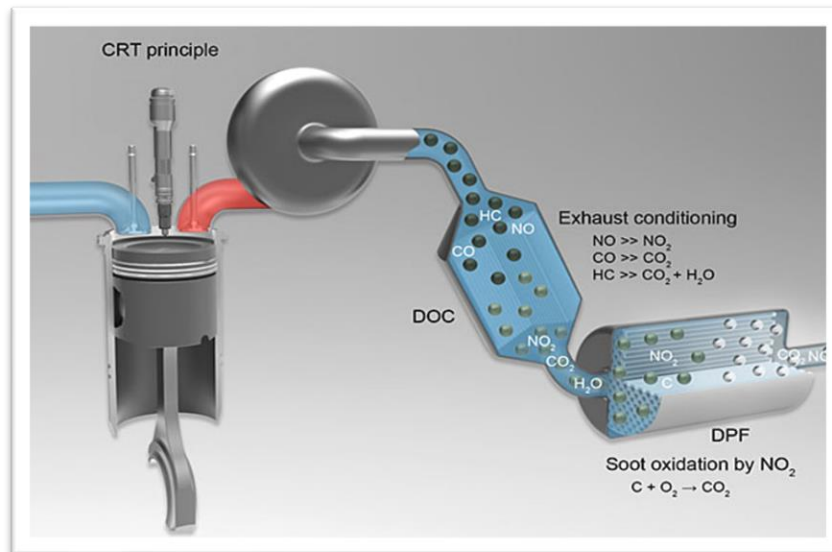
Scrubber Used in Ships to Decrease the Emission of Black Carbon

- **Fuel Switching**

All ships using the residual fuel in their ships are shifted to distilled fuels because the burning of distillate fuel emits less black carbon than residual fuel. The ships that were using residual as their fuel, if they switch entirely to the distillate fuel, will make the emission of black carbon decrease to 67kt to 30kt in 2015. It means if we shift from residual to the distillate to residual fuel, the emission of black carbon would have been decreased to more than half from ships.

- **Installation of Diesel Particulate Filters**

Installing diesel particulate filters (DPF) can reduce black carbon emission by 70-90%. According to research, the ship working on HFO as 1% Sulphur can reduce pm by 80-90% if catalysed DPFs is used with reverse pulse flow can make the emission of black carbon to a much smaller extent. DPFs work more generously when operated with pairs of higher quality distillate fuel, which have lower sulfur and ash contents and fewer impurities that can damage the filters.



How does a DPF works

- **Establishing a Black Carbon Emission Standard for Ships**

Many countries or nations have come together with IMO, which already have established SOX, NOX, and PM standards as pollution control strategies. The IMO is the organization that mainly sees the work of ships. They view every side of ships that are affecting the environment. The IMO has already established the Tier system in which fuels consumption has been discussed. If ships operate using EGCS, a DPF, or by switching to low or zero BC fuels such as Hydrogen and LNG to reduce the emission of the black carbon.

- **Promote Shore Power**

Shore power can significantly reduce air emissions in port, improving local air quality. In nearly all cases, shore power reduces total air and climate pollutant emissions compared with burning HFO and distillate; the level of reduction depends on the source of electricity. Connecting to shore power in port can significantly reduce BC emissions from ships at berth.

## 6. Way to Reduce the Emission of Black Carbon in the Arctic

The route which is currently used to follow the route for shipping can be used as a station where the ships are fuelled till they cross the arctic way so that the burned fuel is limited. Also, in the arctic, there should be a docking system that will make the navigation system much more transparent and more accessible so that navigators and the people or engineers who are present there can follow up on the count of black carbon as well as make the route clear while the ship goes for the checkup and logs checkup. Making everyone's work more accessible and smoother rather than colliding with each other, and for the route clearance, the docking people can make the follow-up route for the ships. The next port should get the ship refueled as we have to consume that much fuel, which is comfortable for both of them.

## **7. Conclusion**

Concerning the above study, we can tell that Black carbon's presence in nature is a bane to humanity, and significant work must be done to stop its emission. All the new technologies that are being introduced should be aimed to control black carbon's emission and eliminate the existing sources of this pollutant. The maritime sector is one of the biggest emitters of this pollutant, and numerous reforms are to be applied to its organization to preserve nature and prevent its exploitation.

## **8. References**

<https://www.imo.org/en/MediaCentre/HotTopics/Pages/Reducing-greenhouse-gas-emissions-from-ships.aspx>

<https://www.sciencedaily.com/releases/2019/02/190220121935.htm>

Ship Energy Efficiency Management Plan(Seemp)

Black Carbon Emissions And Fuel Use In Global Shipping 2015

Chief Eng Narender Singh in BSM

EFC Annirudh Kumar

# TECHNOLOGICAL ADVANCEMENT IN NAVIGATION, COMMUNICATION AND SEARCH & RESCUE IN MARITIME INDUSTRY

Ansh Singh Rajpal<sup>a</sup>  
Tolani Maritime Institute  
ansh.rajpal2020me@gmail.com

Aditya Singh<sup>b</sup>  
Tolani Maritime Institute  
aditya.singh2020me@gmail.com

Abhishek Kumar<sup>c</sup>  
Tolani Maritime Institute  
abhishek.kumar2020me@gmail.com

## ABSTRACT

It is tricky to predict the future, especially in the maritime market – what are the future demands? Which technologies will be available? How will the regulatory bodies think in the future? Within this paper, the recent development towards future requirements and technologies will be spotlighted. One use case scenarios are in the focus here, under the umbrella of Navigation, Communication and Search & Rescue. Marine communication, navigation and Search and Rescue technologies go hand-in-hand in order to provide a safe and secure marine travel on those who are on board a vessel or a ship. These tools are used together to establish rapport between sea ports and nearby vessels, as well as determining a sea or ocean's characteristics and weather patterns.

**Keywords:** Navtor 6.0, AIS-SART, Meosar, Navbox6.0, Artic Communication, LTE Communication

## 1.0 INTRODUCTION

E-navigation is intended to meet present and future user needs of shipping through harmonization of marine navigation systems and supporting shore services. It is expected to provide digital information and infrastructure for the benefit of maritime safety, security and protection of the marine environment, reducing the administrative burden and increasing the efficiency of maritime trade and transport. The expansion of the maritime industry has considerably increased marine traffic. To ensure the smooth facilitation of trades and other services, it is essential for all the ships and vessels on the water to maintain proper maritime communication. Transferring data and status of the vessels back and forth diminishes the margin for errors, keeping the transport fluid. It also helps the ship-to-ship and ship-to-shore communication. Search and rescue (SAR) at sea has been always carried out under principles of the customary law of the sea obliging vessels and states to help persons whose ships are in distress at sea. International treaties define more detailed conditions and obligations to provide adequate SAR. The rationale of all these principles and rules, as well as of the associated duties affecting the obliged persons/states to carry out and organize SAR activities, was that of

increasing safety at sea and taking care of seafarers and fishermen (or passengers on board vessels) who were at sea mainly for the purpose of work.

This paper seeks to explore the technological advancements in marine communication and navigation used in the maritime environment, with veneration to both hardware and software. This paper would invariably serve as a source of information pool for further discussion. We also present some current technological challenges the marine industry is antagonized with.

Following the Ever Given incident, Suez Canal Authority head Osama Rabie speculated that human error may have been the cause rather than unfavourable conditions. The latest navigation technology reduces the risk of future incidents and offers improved efficiency and lower emissions. We investigate some solutions and how they can benefit the shipping industry.

## **2.0 THE CASE FOR E-NAVIGATION**

The e-navigation concept is governed by IMO as the organization responsible for establishing mandatory standards for enhancing the safety of life at sea, maritime security and protection of the marine environment, as well as having global remit for shipping. E-navigation is not a static concept, its development will be ongoing as user requirements evolve and as technology develops.

The Organization developed the e-navigation Strategy Implementation Plan (SIP), introducing a vision for e-navigation and providing the industry with harmonized information in order to start designing products and services to meet the e-navigation solutions.

The main objective of the e-navigation SIP is to implement the following five e-navigation solutions:

S1: improved, harmonized and user-friendly bridge design;

S2: means for standardized and automated reporting;

S3: improved reliability, resilience and integrity of bridge equipment and navigation information;

S4: integration and presentation of available information in graphical displays received via communication equipment; and

S5: improved communication of VTS Service Portfolio (not limited to VTS stations).

### **2.1 NAVTOR 6.0**

NAVTOR is a leading force in the provision of innovative e-Navigation solutions, and a total supplier of navigational products and services for the maritime sector. Every day the company strives to make life easier for navigators, and safer, clearer and more efficient for shipowners, ship managers and operators.

NAVTOR latest announcement is a major upgrade of its NavStation software, introducing new features delivering enhanced security, usability, accuracy and efficiency for an increasingly

digitized shipping industry. The solution, which originally launched in 2014 as the world's first digital chart table, has been revamped to offer more seamless passage planning, faster and higher quality rendering of charts, even more robust cyber security, and better functionality for busy vessel navigators.

NavStation has undergone constant evolution since its arrival. A continual process of innovation has seen features including the much-vaunted passage planning (PP) module added (cutting PP administration time from an average of over three hours per voyage to 30 minutes). Navigators now have everything they need to take vessels from berth to berth on one seamless platform, while land-based teams get a new level of oversight and control. NavStation 6.0 takes this to the next level. Navtor now has products and services on over 7000 vessels worldwide, with customers in over 60 countries and that really helps them 'see through industry eyes' and identify ways their digital innovations can deliver real world benefits. From both a navigator and owner/operator perspective NavStation has the potential to provide new efficiencies, security and data sharing, accelerating our customers journeys to more sustainable, cost-effective maritime operations.

NavStation 6.0 sets a new industry standard and, when seen as part of our wider e-Navigation ecosystem, is key to enabling smarter shipping today.

The new software Navtor 6.0 has a number of stand-out features. PP improvements see the addition of parameters including overhead clearance and improved under keel clearance functionality, as well as the ability to activate the PP and share it with NAVTOR's recently launched NavFleet monitoring and performance tool. This means shore-based teams (using NavFleet) have greater insights and control into vessel operations, allowing for on-going awareness and optimisation.

Security has been bolstered to protect data integrity, with more robust communication between NavStation and NavBox (the digital gateway, or hub, connecting vessels with organisations on shore). NavBox is certified cyber secure by DNV. Users benefit from the ability to create their own chart layers over ENC's on NavStation 6.0, populating them with objects tailored to their specific needs.

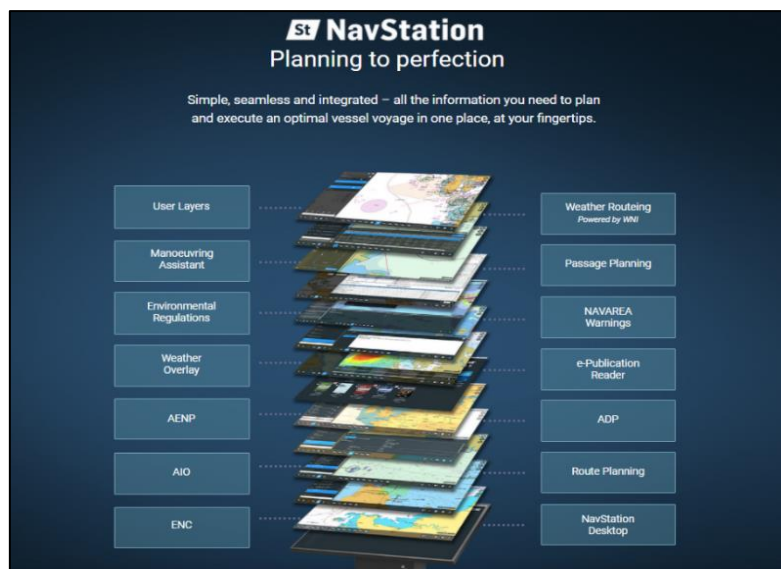


Fig1: NavStation- Planning to Perfection

### **2.1.1 Taking control**

Data is the key. e-Navigation relies on sharing data between sea and land – pushing the very latest digital charts and publications from locations on shore to those on the bridge, ensuring safe, compliant and predictable vessel operations. But to do that it needs a pathway, and a gateway, creating a seamless and secure method of transferal.

Smart shipping mean shipping with reduced costs, increased efficiency and more sustainable operations, is digital. To meet those objectives we need data, and from that data we can empower better decision making, improved processes and, in short, greater control. But to achieve this we have to share the data seamlessly from ship to shore and back again, creating one joined up operational entity where everyone has the information and oversight required for optimal performance.

### **2.1.2 Gateway to progress**

In NAVTOR's case the firm has created that infrastructure with a device called the NavBox. This operates as a DNV GL certified cyber-secure gateway, feeding encrypted information to and from vessels via satellite. It enables the firm to automate the distribution and update of digital charts, publications and other navigational data for its customers.

The NavBox is a gateway which, working with the digital chart table NavStation, allows all sorts of operationally relevant data to be shared with shore, while those on the bridge can access all the very latest information they need to plan and execute optimal, compliant and safe voyages.

This ranges from real-time weather information, to security alerts, regulatory information (encompassing everything from international rules to individual port requirements) and vessel traffic, all accessed as 'layers' over digital charts so bridge officers have a complete navigational tool at their fingertips. Processes can be automated and administration burdens slashed (with a Passage Planning module reducing admin time from an average of over three hours to under 30 minutes per vessel, per voyage), translating to a huge economy across fleet

### **2.1.3 Hand in hand benefits**

Increased automation reduces human error and enhances safety, while digitally optimized routes - taking into account factors such as real-time weather conditions and tidal patterns - can deliver significant vessel fuel savings.

This is good for the environment and, when you consider that fuel accounts for a huge slice of vessel OPEX that is very good for business and that's the essence of smart shipping – using technology to deliver tangible benefits, for business and for society, with greater efficiency, reduced costs and smaller eco footprints. Those things really do go hand in hand.

Access to data allows those on shore to have eyes on the ship, controlling operations and optimising performance. When you combine individual vessel data with wider data – from ports, relevant authorities and other vessels – you can 'join the dots' to give a full overview of

ship movements, allowing for safe traffic, predictable operations and optimal efficiency (with, for example, ‘just in time’ port arrivals).

“This may sound like science fiction, but it’s possible now.” -Hetland (CCO of Navtor)

#### **2.1.4 Smart steps forward**

With future developments land based teams will be able to see real-time data from, for example, engine room sensors and adjust performance accordingly to meet objectives. Cargoes can be monitored, automated reports produced for regulatory and environmental control, energy consumption can be optimized, and (with wearable sensor technology) exact crew locations can be fed to response and rescue teams in emergency situations. And that’s just a few examples.

This will provide something akin to 360-degree real-time awareness – on vessels and on shore – like never before. It’s a true game changer for the shipping industry.

E-Navigation is about making connections: about sharing data, about gathering intelligence and about making better decisions, with less workloads, less costs, less risks and less impact on the environment. That is the very essence of smart shipping, and that is the route this industry needs to follow.

### **3.0 COMMUNICATION**

Two incidents indicate the importance of communication. The first is about a crossing of the Suez Canal. A ship accidentally swung into the coast, causing damage. However, the pilot and officers on deck did not report the incident to the master of the next shift. As a result, the damage worsened, and the hull fractured in the dock later on, making the problem worse.

The second incident is a case where a ship had a malfunction with a steam valve while at sea. Staff members were down to two valves out of three, but they neglected to report this to the port when they docked. That meant they didn’t get repairs in time and wound up being blacklisted from that port for future use. Both of these incidents came about because of missed opportunities to communicate important information about the ship’s condition, leading to missed handovers and worse outcomes.

Throughout the years, several different forms of communication have been practiced- Morse code, semaphores, flags and radio, and telephone services. As technology advances, it has become important for the communication systems aboard the ships to be upgraded as well. Satellite communication is the new, upcoming form of communication that has proved to be extremely beneficial and convenient.

Maritime communications will experience major changes during the next two decades. Not only will the evolution of e-Navigation require higher digital data exchange capacities, but new connectivity solutions for the crew will also increase bandwidth needs. New potential digital VHF services are envisioned while other innovative digital VHF implementations are also in the pipeline. These are only some examples of emerging trends, technologies or demands.

### **3.1 LTE COMMUNICATION**

Contrary to these revolutionary improvements of wireless communications on land, providing reliable and high-speed data services for maritime users is still a challenging issue. In general, maritime environments have the geographical limitation for developing communication infrastructures such as base station (BS) of LTE and access point (AP) of Wi-Fi. This makes those maritime communications need more extended communication coverage than terrestrial communications. Legacy maritime communication systems such as automatic identification system (AIS) and global maritime distress and safety system (GMDSS) have the extended communication coverage based on medium frequency (MF), high frequency (HF), and very high frequency (VHF). However, due to the small channel bandwidth allocated for these maritime systems, they cannot support high data rate services. In addition, although satellite communication systems could satisfy the communication needs for high data rate and extended coverage, the cost and size of satellite communication remain severe obstacles for typical maritime users. By considering these limitations of current maritime systems, there is a strong need by maritime users for reliable, high-speed, and cost-effective communication system.

In order to meet the communication requirements of maritime users, in the Republic of Korea, an LTE-Maritime project was recently launched with the objective of providing the communication coverage of 100 km and high data rates in the order of megabits per second. The basic idea of LTE-Maritime is applying LTE technology currently used in the terrestrial region to the maritime domain. Throughout this section of the paper, we focus on answering the question “Could LTE technology satisfy the communication coverage and data rate requirements in maritime environments?”. This paper is organized as follows. Finally, we conclude this section of the paper with future research directions.

#### **3.1.1. Maritime Service Requirements**

According to the maritime radio communications plan (MRCP) developed by the international association of marine aids to navigation and lighthouse authorities (IALA), the maritime services can be divided into three types of safety service, operational service, and commercial service

Typical maritime services such as AIS, GMDSS, search and rescue (SAR), maritime information overlays (MIO), and electronic chart updates are used in most of vessels in order to assure the safety of life and efficient voyage at sea. These services require relatively low data rates and their maximum requirement is 100 kbps. However, as maritime equipment and services are modernized, the data rate requirements of maritime services have been gradually increasing. For example, e-Navigation services are being developed to support the safety and efficient navigation specialized in Korean waters. It is estimated that they need the data rates of 1.56 Mbps based on the simulation test. Further, in order to prevent marine accidents, vessels are equipped with a lot of sensors. It is reported that the data transmission of sensor information collected from LiDAR and infrared camera requires a couple of megabits per second. Besides the safety issues, many crews and passengers want to enjoy the daily of life on the voyage. The infotainment (information and entertainment) service for social communication and interaction with family and friends requires the data rate of 1.5 Mbps. Based on this classification, a variety of maritime data services and their data rate requirements are summarized in Table below.

TABLE:1 Service Classification and Data Rate Requirement

| Service type        | Service                         | Data rate requirement (kbps) |
|---------------------|---------------------------------|------------------------------|
| Safety service      | Radar/AIS plot                  | 100                          |
|                     | GMDSS data                      | 10                           |
|                     | Mechanical sensors              | 10                           |
|                     | HD video                        | 1500                         |
|                     | LiDAR                           | 2000                         |
|                     | Infrared camera                 | 1000                         |
|                     | VTS coordination                | 100                          |
|                     | SAR                             | 100                          |
|                     | Special data gathering          | 1500                         |
| Operational service | Weather data                    | 9.6                          |
|                     | Ship reporting                  | 9.6                          |
|                     | Notifications to coastal States | 9.6                          |
|                     | Port arrival notification       | 9.6                          |
|                     | MIO                             | 100                          |
|                     | Load/discharge coordination     | 100                          |
|                     | PPU/VTS image                   | 100                          |
|                     | Tug/mooring coordination        | 100                          |
|                     | Electronic chart updates        | 100                          |
| Commercial service  | Korean e-Navigation services    | 1560                         |
|                     | Voyage orders                   | 9.6                          |
|                     | Commercial port services        | 9.6                          |
|                     | Operational reports             | 9.6                          |
|                     | Cargo telemetry                 | 64                           |
|                     | Payments and inventory          | 64                           |
|                     | VoIP                            | 140                          |
|                     | Passenger internet access       | 150                          |
|                     | Crew training                   | 9.6                          |
| Infotainment        | 1500                            |                              |

### 3.1.2 LTE-Maritime

LTE-Maritime aims at developing a new wireless maritime network that enables maritime users to access a variety of data services requiring the high data rates in coastal areas of 100 km from a shore. The overview of LTE-Maritime communication architecture in the project is illustrated in Fig. 1 and the main features of LTE-Maritime are followings.

- LTE-Maritime is based on LTE technology that is a promising solution for wireless maritime network. LTE is capable of providing increased data rate, capacity, and spectral efficiency even in dynamic propagation environments with the support of advanced techniques such as MIMO and carrier aggregation (CA). Furthermore, it has the potential to provide the communication coverage about 100 km depending on the cell environments, though LTE for commercial mobile communication is designed with a relatively short cell coverage. This superiority of LTE makes us develop a single-hop network enabling ship-to-shore data communication based on LTE technology. LTE-Maritime enables ships to communicate with onshore BSs directly and it can improve reliability. Therefore, it is more suitable especially for the safety related maritime services that require high reliability as well as low latency.

- LTE-Maritime consists of base stations (BSs), evolved packet core (EPC) equipment, and routers. A number of BSs are located at a high altitude of mountainous areas along the coastline to assure the line of sight (LoS). Each BS is composed of multiple radio units (RUs) and digital units (DUs). The RU and DU are responsible for radio transmission and reception, and for data processing, respectively. Every DU is connected to LTE-Maritime operation center through the

wired network. It is equipped to compass deck of ship with high gain antennas of 6 dBi and the antenna length of 1.2 m. It could provide better communication performance than typical mobile devices.

- The performance goal of LTE-Maritime is divided into two cases depending on the distance from the coastline. The objective of region A is to cover the area from BS to 30 km with the average data rates of 6 Mbps and 3 Mbps for downlink (DL) and uplink (UL), respectively. The objective of region B is to cover the area from 30 km to 100 km with the average data rates of 3 Mbps and 1 Mbps for DL and UL, respectively. The coverage objective was set based on the fact that 88% of marine accidents in Korea happen in non-SOLAS ships within the coverage of 100 km.

- It is expected that LTE-Maritime can support various e-Navigation services for marine accident prevention and effective navigation. The e-Navigation services include navigation monitoring and assistance, ship-borne system monitoring, safe and optimal route planning service, real-time electronic navigational chart distribution and streaming, pilot and tug assistance, and maritime environment and safety information. In addition, LTE-maritime network could provide various data services for maritime users with improved reliability, high data rate, long enough coverage, and low cost compared to current maritime networks.

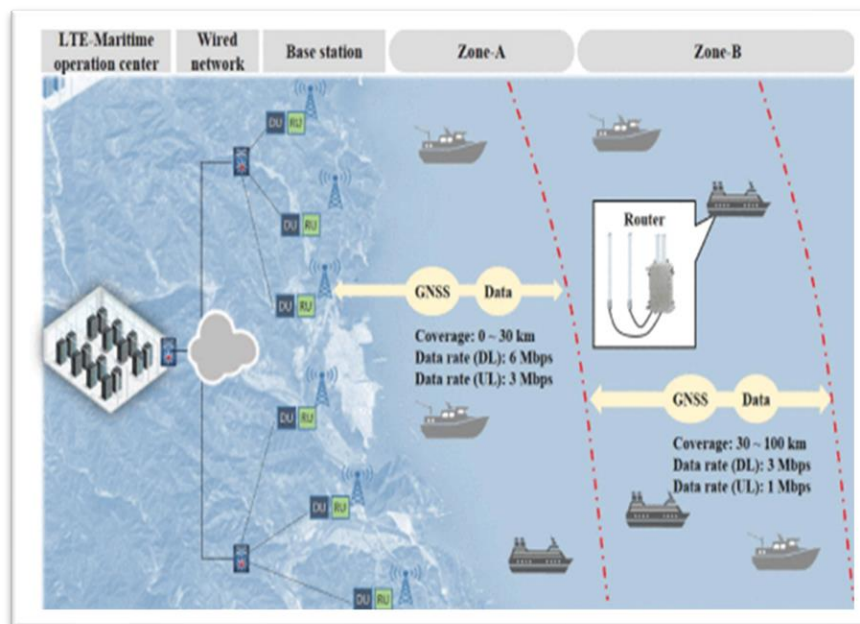


Figure 2: LTE-Maritime communication architecture.

### 3.1.3 Future Vision

In this section of the paper, we have provided a survey on the wireless maritime networks to confirm how much existing maritime communication systems can support the emerging service requirements. This survey reveals that existing maritime systems have the limitations of the low data rate of legacy maritime communications and the high cost of satellite communications. The onboard experiments conducted on the testbed show that LTE-Maritime can support high data rate in the order of Mbps while providing long coverage around 100 km.

Furthermore, we discuss several considerations such as antenna location, movement management, interference management, and QoS control that still need to be addressed. Future research directions are to derive a maritime propagation loss model through lots of onboard measurements and conduct a cell planning based on the derived propagation model. HO, interference management, and QoS scheduling algorithms will also be developed to optimize the LTE-Maritime performance by considering maritime characteristics.

## **4.0 SEARCH AND RESCUE**

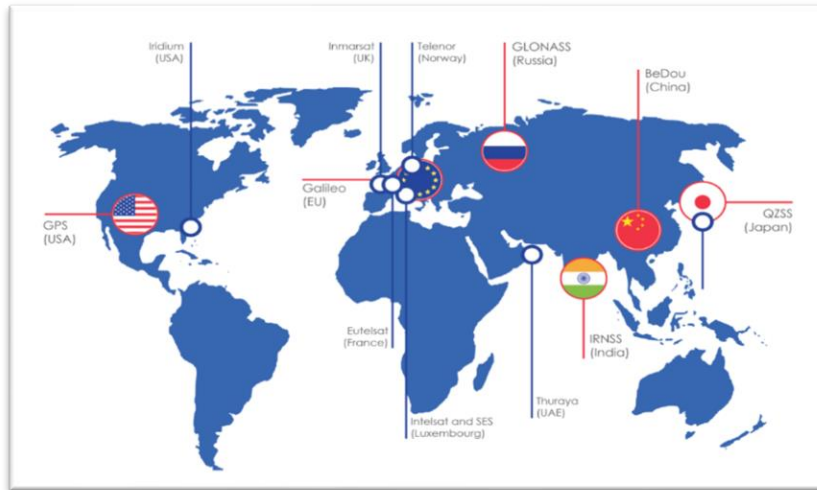
The infancy and youth of radio technology was primarily linked to maritime applications. Following his invention of the first operating radio transceiver in 1895, Guglielmo Marconi performed transmission experiments between two Italian warships outside the port of Spezia in 1897, where he managed to exchange radio messages at a distance of 22 km. Later he continued his experiments in England, where on Christmas Eve in 1898 he established radio telegraphy contact between the “East Goodwin” lightship and South Foreland Lighthouse in South East England. On 3rd March 1899 the steamship “R F Matthews” collided with this lightship, which alarmed the lighthouse ashore to obtain assistance. This was the first time ever a distress call was transmitted by radio from a ship at sea.

### **4.1 MEOSAR**

Cospas-Sarsat is an international satellite system for search and rescue (SAR) distress alerting that was established in 1979 by Canada, France, the USA and the former USSR. Since its inception the Cospas-Sarsat Programme has continually expanded and, as of 2010, 43 countries and organizations share in the management of the System. At the end of 2009, more than 28,000 people had been rescued through the use of the System. The System originally comprised satellites in low-altitude Earth orbit (LEO). The LEO satellites and associated ground receiving stations (referred to as the LEOSAR system) receive signals from distress beacons operating at 406 MHz. The LEOSAR system calculates the location of distress beacons using the Doppler effect on the received beacon signals. Because of LEOSAR satellite orbit patterns, there can be delays between beacon activation and the generation of an alert message.

Geostationary satellite footprints are fixed with respect to the Earth’s surface; therefore, each satellite provides continuous coverage over the geographic region defined by its footprint. This reduces the detection delays associated with the LEOSAR system. Because of their altitude each GEOSAR satellite provides coverage of a very large area (about one third the surface of the Earth excluding the Polar Regions). However, because of these attributes (i.e. stationary with respect to the Earth and high altitude):

In 2019, the USA, the European Commission (EC) and the Russian Federation began consultations with Cospas-Sarsat regarding the feasibility of installing 406 MHz SAR instruments on their respective medium-altitude Earth orbit navigation satellite systems (hereafter referred to as MEOSAR constellations) and incorporating a 406 MHz MEOSAR capability into the Cospas-Sarsat System. The USA MEOSAR system is called the SAR/GPS, the European system is called SAR/Galileo, and the Russian system is referred to as SAR/GLONASS.



*Fig 3: Meosar Satellites*

Initial investigations identified many possible SAR alerting benefits that might be realized from a MEOSAR system, including

- near instantaneous global coverage with accurate independent location capability,
- robust beacon to satellite communication links, high levels of satellite redundancy and availability,
- resilience against beacon to satellite obstructions, and
- the possible provision for additional (enhanced) SAR services, such as a ground to beacon return link.

The primary missions for the three MEOSAR constellations, i.e. the Global Positioning System (GPS), Galileo and GLONASS, generally referred to as global navigation satellite systems (GNSS), are positioning, navigation, and timing. As a secondary mission, the SAR payloads have been designed within the constraints imposed by the primary mission payloads.

The three MEOSAR satellite constellations will use transparent repeater instruments to relay 406 MHz beacon signals, without onboard processing, data storage, or demodulation/remodulation. MEOSAR satellite providers will make their satellite downlinks available internationally for processing by MEOLUTs operated by MEOSAR ground segment participants.

#### **4.1.1 Meosar: The System Evolution**

The primary missions for the three MEOSAR constellations, i.e., GPS, Galileo, and GLONASS, are positioning, navigation, and timing. As a secondary mission, the SAR payloads have been designed within the constraints imposed by the primary mission payloads. For these and other reasons, the three MEOSAR satellite constellations use “transparent” repeater instruments to relay 406 MHz beacon signals, without onboard processing, data storage, or demodulation/remodulation. MEOSAR satellite providers will make their satellite downlinks

available internationally for processing by MEOLUTs operated by MEOSAR ground segment participants.

This important change in the space segment has various consequences for the system:

- Having repeaters and several satellites in visibility ensures global coverage and a real-time transmission of the alerts.
- Having repeaters instead of on-board processors will allow system upgrades to completely change the transmitted signal for the next generation of beacons without affecting the space segment. Of course, the ground segment will need to be updated.
- The spatial diversity of the MEO constellation allows a different use of TOA and FOA measurements. For example: a moving beacon can be located and its velocity can be estimated as well.

#### 4.1.2 How Does Meosar Work?

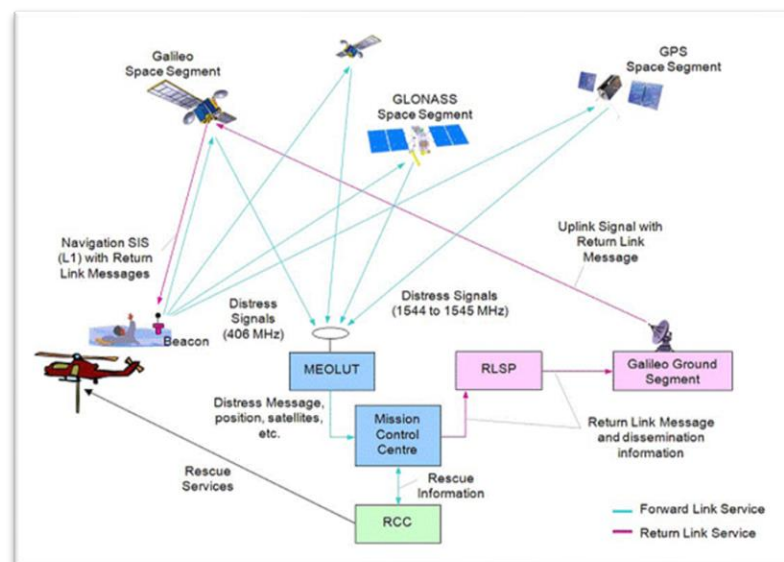


Fig 4: Major components of the MEOSAR system

1. A distress beacon is activated and sends a 406MHz message. The message includes the beacon id (also known as the Hex id or UIN). If the beacon has a GPS, the message will include the GPS location.
2. Any MEOSAR satellites that detect the distress beacon relay the message back to earth on 1544.1MHz. The relayed message is detected by a MEOLUT.
3. If a MEOLUT receives sufficient information (typically, relay from three or more MEOSAR satellites) a location for the beacon can be calculated. The MEOLUT sends all information available from the beacon (the beacon id, the GPS location if it exists and the MEOSAR location if it can be calculated) to its associated Mission Control Centre (MCC).

4. The MCC forwards beacon information to the relevant Rescue Coordination Centre (RCC). If the beacon was located in New Zealand, for example, the beacon information would be forwarded to the New Zealand RCC in Wellington. If the beacon as located in Australia, the information would be forwarded to RCC Australia in Canberra.

5. The RCC then coordinates the search and rescue associated with the beacon activation.

### **4.1.3 Second-Generation Beacons Under Meosar**

In parallel with the MEOSAR transition, operational requirements are under definition for a new generation of distress beacons. These second-generation beacons should ensure better system performance and allow for new purposes.

One of the remarkable new requirements concerns the increased accuracy standards for the independent location performance:

- 5 kilometers, 95% of the time, within 30 seconds after beacon activation
- 1 kilometer, 95% of the time, within 5 minutes after beacon activation
- 100 meters, 95% of the time, within 30 minutes after beacon activation.

### **4.1.4 A Way Forward**

MEOSAR system is currently being deployed along with associated activities to prove that this safety-of-life system will work with a high level of reliability and ensure a smooth transition from the current LEO/GEO system. But we can already say that this evolution from LEO/GEO to MEO/GEO system tends to meet the required improvements in availability and independent location accuracy. The use of second-generation beacons will further dramatically increase this performance, including for moving beacons, opening new services such as in-flight activation and, ultimately, saving more lives.

## **CONCLUSION**

This paper documents the areas of intervention to satisfy the future demands for maritime communications, navigation and search and rescue using the state-of-the-art technologies. Identified areas are: NAVTOR 6.0, Integrated Awareness System LTE Communication Arctic communications, AIS-SART, MEOSAR. This paper provides for the three areas a description of the areas where the integration of these technologies is able to increase the services availability in maritime market and a list of the user's requirements.

These advanced maritime systems have a lot of opportunities of enhancing facets of obligatory works for mariners, maritime administration, centered on various integrated technologies. The various maritime information will contribute to effectively reducing workloads of mariner with an improvement in security and safe navigation.

## **ACKNOWLEDGMENT**

The completion of this undertaking could have not be possible without the participation and assistance of so many people whose names may not at all enumerated. Their contributions are appreciated and gratefully acknowledged.

We also extend our sincere thanks to our worthy Mentors Prof. Pavan Jadhao and Prof. Nitin Junarkar and our seniors Cdt. Nayan Bhawrani and Cdt. Ujjwal Gehlot for their guidance and support and for putting their precious time and efforts for the successful completion of this paper.

## **REFERENCES:**

1. <https://www.ship-technology.com/features/innovations-in-maritime-navigation-software/>
2. <https://www.navtor.com/post/e-navigation-to-chart-way-forward-for-shipping>
3. Satellite Internet Service Providers in Middle East and Europe', Satellite Internet and VSAT Information Centrum
4. <https://insidegnss.com/meosar-new-gnss-role-in-search-rescue/>
5. [https://www.researchgate.net/publication/4372857\\_Recent\\_Improvements\\_in\\_Satellite\\_Networks\\_for\\_Search\\_and\\_Rescue\\_MEOSAR](https://www.researchgate.net/publication/4372857_Recent_Improvements_in_Satellite_Networks_for_Search_and_Rescue_MEOSAR)
6. <https://www.ship-technology.com/features/innovations-in-maritime-navigation-software/>
7. <https://www.marineinsight.com/shipping-news/navtor-helps-europe-take-ai-enabled-route-to-safe-secure-and-efficient-maritime-future/>

# IMO'S GHG STRATEGY: HOW TO MEET 2030 AND 2050

Potti Tagore<sup>a</sup>, Praveen Singh<sup>b</sup> and Parag Bhati<sup>c</sup>

<sup>a</sup>Indian Maritime University, Chennai Campus, tagore20031975@gmail.com, 9059855677

<sup>b</sup>Indian Maritime University, Chennai Campus, praveensingh0830@gmail.com, 8000166672

<sup>c</sup>Indian Maritime University, Chennai Campus, bhatisakar690@gmail.com, 7062973762

## **Abstract:**

In today's world, Major concern is regarding the increase in pollution. Compared to all other industries pollution made by the shipping industry is low. To make IMO 2030 and 2050 goals to reduce the pollution of the shipping industry to very low can be done by replacing IC Engines with Super Magnets Motors (Using Super Conductors). With this technology, we will be able to reduce the pollution in the maritime field to 100%.

**Keywords:** Emission, Global House Gas, IC Engine, Super Magnet Conductors

## **Introduction**

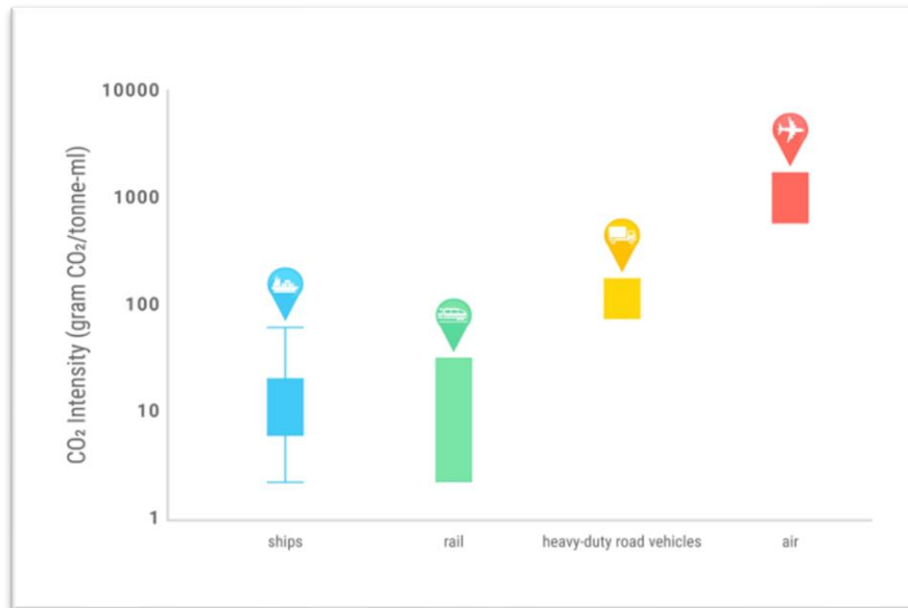
Our world is getting warmer. Over the last 100 years the average temperature of the Earth's surface has risen by about 0.8°C. Ocean acidity is increasing; ice sheets are shrinking and sea levels are now rising twice as quickly as during the last century. Scientists agree that if climate change is not stopped, in forty years' time large areas of the earth's surface will look very different to the way they do now. The consequences of these changes are unknown and unpredictable. To overcome the consequences a small initiative toward industry which can reduce the GHS emission to 100% by installing Super Magnets Motors (Super Conductors) instead of IC engines. With this initiative the fuel consumption will completely negligible and will require less maintenance on comparison to IC engine or any other engine.

## **Vision of IMO by 2030 and 2050:**

The Vision of IMO by 2030 and 2050 is the initial GHG strategy envisages, in particular, a reduction in carbon intensity of international shipping (to reduce CO<sub>2</sub> emissions per transport work, as an average across international shipping, by at least 40% by 2030, pursuing efforts towards 70% by 2050, compared to 2008); and that total annual GHG emissions from international shipping should be reduced by at least 50% by 2050 compared to 2008.

## **Emissions from the transport sector:**

Transportation is a key contributor to emissions, accounting for about 14% of global GHG emissions. Greenhouse gas emissions from this sector primarily involve petroleum-based fuels burned for road, rail, air, and diesel-based fuels for marine transportation. As can be seen from the graph, which shows the amounts of carbon dioxide emitted per tonne of cargo/mile by different modes of transport, shipping is a comparatively efficient method of transporting goods. It generates less carbon dioxide per tonne of cargo/mile than any other transport mode.



**Emission from shipping industry:**

However, although shipping is the most efficient mode of mass cargo transport, shipping does produce GHG emissions. The IMO has undertaken several studies to understand the emissions generated by ships. According to the Fourth IMO GHG study, international shipping, in 2018, was responsible for approximately 2% of global carbon dioxide emissions. This may not sound a lot, but is comparable to emissions from major GHG emitting countries, such as for example Germany.

| Year | Global anthropogenic CO <sub>2</sub> emissions | Total shipping CO <sub>2</sub> | Total shipping as a percentage of global | Voyage-based International shipping CO <sub>2</sub> | Voyage-based International shipping as a percentage of global |
|------|--|--------------------------------|--|---|---|
| 2012 | 34,793   | 962                            | 2.76%                                    | 701   | 2.01%   |
| 2013 | 34,959   | 957                            | 2.74%                                    | 684   | 1.96%   |
| 2014 | 35,225   | 964                            | 2.74%                                    | 681   | 1.93%   |
| 2015 | 35,239   | 991                            | 2.81%                                    | 700   | 1.99%   |
| 2016 | 35,380   | 1,026                          | 2.90%                                    | 727   | 2.05%   |
| 2017 | 35,810   | 1,064                          | 2.97%                                    | 746   | 2.08%   |
| 2018 | 36,573   | 1,056                          | 2.89%                                    | 740   | 2.02%   |

**Green House Gases (GHG) and its effect:**

The Earth environment as we know it exists because of the energy it receives from the Sun. The absorbed sunlight drives photosynthesis, causes the majority of water to be present in a liquid state and warms the Earth system. When short wavelength, ultraviolet radiation from the Sun reaches the Earth, some of it is reflected by the atmosphere back into space. Some of that radiation is absorbed by the atmosphere during its passage to the Earth’s surface. About half

of that radiation reaching the Earth's surface is absorbed, thereby keeping the Earth warm. However, the Earth retransmits some of that energy back into the atmosphere but now as long wavelength, infrared radiation. But the increasing amount of carbon dioxide and other greenhouse gases humans are emitting into the atmosphere is enhancing the greenhouse effect. These gases absorb some of the infrared radiation energy leaving the Earth acting as a "glass roof on the atmosphere", letting sunlight in, but absorbing more of the infrared radiation that gets reflected by the Earth into the Atmosphere. This means that more energy, in the form of heat, is trapped in the atmosphere, resulting in rising global temperatures and other changes to our climate.

### **Impact of IC Engines on shipping industries**

The development of the internal combustion engine helped to free men from the hardest manual labour, made possible the ship and other forms of transportation, and helped to revolutionize power generation.

With the boon of IC Engine there are so many negative factors which affects the nature, As intensity of detonation increases, the sound intensity increases & it is harmful. Mechanical damage – shock waves are so violent that it may cause mechanical damage like breaking of piston. It increases the rate of wear erosion of piston.

Internal combustion engines operate by burning fossil fuel derivatives and produce exhaust emissions, which are their major contribution to environmental pollution. Noise and odour pollution is also created by internal combustion engines.

- Fuel utilized is expensive like gas or diesel.
- Motor discharges are commonly high contrasted with outer burning motor.

Most internal combustion engines are only 20 percent thermally efficient. In addition to heat, the various systems required to run the engine all take energy that could potentially be put to use propelling the Ship.

Each gallon of hydrocarbon-rich petroleum fuel that is used to power ship today produces nearly 20 pounds of carbon dioxide (CO<sub>2</sub>), resulting in the annual emission of over 1.5 billion metric tons of CO<sub>2</sub>, or roughly 1/3 of the total greenhouse gas emissions.

### **Use Of Super Conductors**

The Use of super magnets Conductors will be the boon toward the environment as their will be no pollution on using this technology. The three terms which describe superconductors are critical temperature, Critical field, critical current. Critical temperature is the temperature at which the material loses its resistivity and becomes superconductors. Critical magnetic field is a magnetic field that is applied across a superconductor to loses its super conduction before critical or below critical temperature. Maximum current which superconductors can carry is known as critical current for Nb-Ti conductor it is extrinsic properties. Generally, we use Nb-Ti with (impurities) we use to make superconductors because of the high critical magnetic field.

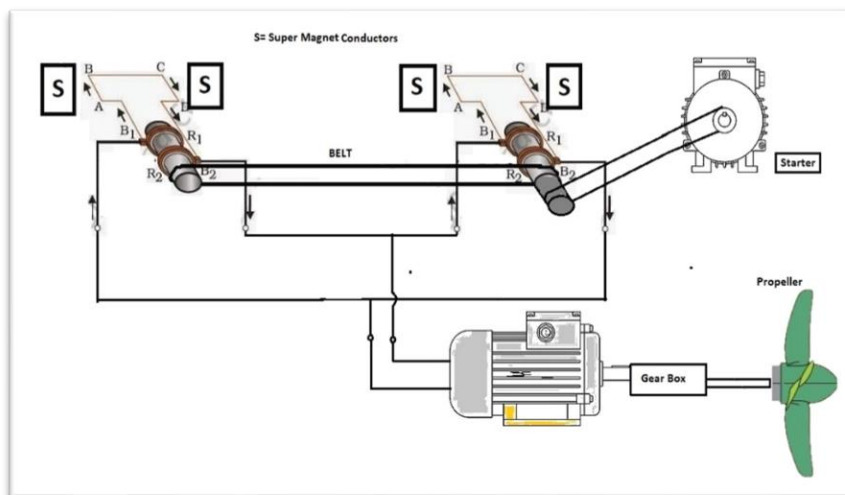
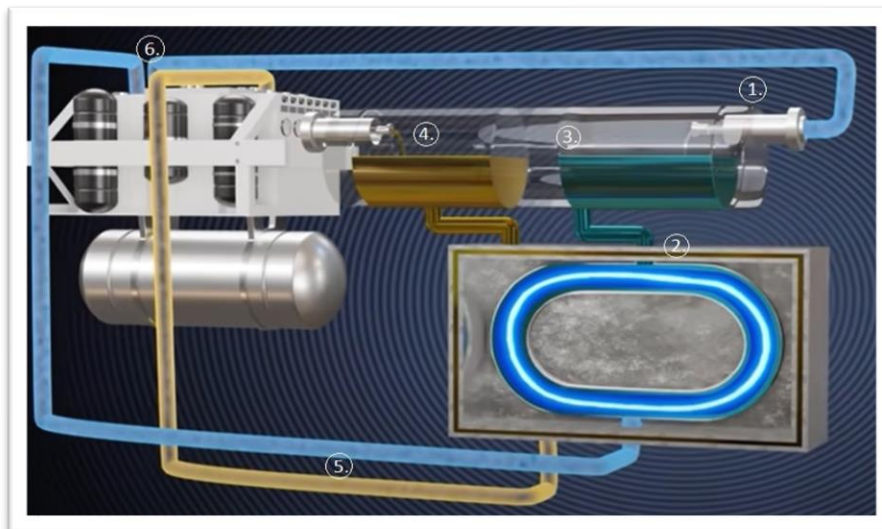
Normally critical temperature of Nb-Ti is 10k but to increase its critical magnetic field limit we use lesser temperature then 10k up to 4.63k(4.5k). We use superconductors because they can carry high electricity then normal electromagnets. Exciting this is that we charge the superconducting coil once exciting current in order for the short-circuited coils to produce a circulating DC current forever with no energy loss the current circulated by the

superconductivity coils is very huge (max up to 700 KA in may ten train) 10000 times more than conventional house hold copper gauge wires.

The Superconducting electromagnets are obviously the most powerful and efficient electromagnets.

Because of exceeding critical current, it should be cooled continuously by liquid helium refrigeration is used along with compressor to not let any loss of the refrigeration and compression will occur simultaneously after another as shown in Figure below Since there was another problem since heat can be absorbed by radiation shield through which eddy currents can form so radiation shield also need liquid nitrogen.

1. Gifford Mcmacon Refrigeration cycle
2. Radiation Shield
3. Liquid Helium
4. Liquid Nitrogen
5. Gases of both Helium and Nitrogen
6. Gifford Mcmacon Compressor



### **Working:**

As shown in the above figure the arrangement should be done with the help of superconductors we will have high magnetic flux to make coil rotate, as we said first it's is perpetual motion equipment at the start we should apply some torque to start the motion so we are applying some torque by some external means know as starter in the figure and then one super magnet motors start rotating with the help of starter this started super magnet motor makes other super magnet motor rotates with the help of conver belt these rotates each motors simultaneously and makes electricity to flow and hence we get high amount of electricity in which some electricity is used to rotates first motor and by belt second one rotates and not to make second motor take electricity we use germanium diode to allow flow of current trough one direction and we will get maximum electricity near diodes.

### **Conclusion**

Pollution is a major Concern which needs to be reduced, Shipping Industry is daily putting great efforts to reduce fuel consumption and to get rid of pollution. The EEDI regulations are intended to encourage new ship designs, more efficient engines and the development and installation of innovative energy efficient technologies. Since 2013, depending on ship type and tonnage, newly constructed ships and major conversions, must comply with IMO's energy efficiency regulations. These regulations require a ship to be built to meet a minimum energy efficiency level which is expressed in terms of its EEDI. Without IC engines we can't see existing shipping life but introduction of super magnets will revolutionarily change. which will ease the life and reduce the pollution in environment and make the Earth better place for our generation.

### **Acknowledgment:**

We would like to acknowledge and give my warmest thanks to Dr Thagnlakshmi Mam who made this work possible. Her guidance and advice carried me through all the stages of writing my project. We would also like to thank my committee members for letting my defense be an enjoyable moment, and for your brilliant comments and suggestions, thanks to you.

Finally, I would like to thank God, for letting me through all the difficulties. We have experienced your guidance day by day. You are the one who let us finish our project. We will keep on trusting you for our future.

### **Reference:**

1. <https://unccelearn.org/>
2. <https://www.youtube.com/watch?v=XjwF-STGtfE&t=206s>

# REVIEW ANALYSIS ON ADVANCEMENTS IN NCSR TECHNOLOGIES

Akankshaya Priyadarshini Rathaa, Erin Antob and Ritika Haridas Nairc

<sup>a</sup>Indian Maritime University, Visakhapatnam Campus, apr.thuku22@gmail.com,6371145089

<sup>b</sup>Indian Maritime University, Visakhapatnam Campus, erinan3102@gmail.com, 9778228578  
(Paper Presenter)

<sup>c</sup>Indian Maritime University, Visakhapatnam Campus, ritikahari@gmail.com ,7558015324

Indian Maritime University, Visakhapatnam Campus, Department of Naval Architecture & Ocean Engineering, Vangali Post, Sabbavaram Mandal, Andhra Pradesh- 531035

## ABSTRACT:

Sea-going is a perilous task as the working medium is quite unpredictable. The only way to survive the waves is instant harmonization to the impulsive sea conditions through prudent utilization of available amenities and efficient action-response sequences in unfortunate junctures. To override the hurdles of the industry, a pertinent technical evolution from semaphores and flags to contemporary technological standings has taken form and dimensions in navigation, communication & search, and rescue. This paper tries to analyze the ever-evolving trends, ameliorations, competent protocols, and innovations in these sectors, finally leading to a conclusion discussing the risks associated with the software-oriented technological revolution in maritime commerce.

## KEYWORDS:

V-AIS, Aid to Navigation (AtoN), TRAPs, Vessel Triage, NCSR (Navigation, Communication & Search and Rescue)

## INTRODUCTION:

While shipping is the most international of the world's largest industries, it is considered to be very challenging given the comprehensive figures of catastrophic consequences in the form of accidents, disasters, loss of lives, property, cargo, and environmental damage cited in the statistical specifics. Despite the jeopardies and challenges it offers, the maritime industry is still an inevitable card in the world economy. Fortunately, the digitalization of the shipping industry and modern technological advancements have made marine navigation more reliable and reduced the potential loss of lives, undue commercial cost, administrative burden, and damage to the environment. Furthermore, SAR technologies have been upgraded and refined by changing emergency conditions canvassing the industry's demands for intelligent solutions. To make navigation and SAR operations brisk, lenient, and efficient, paramount research and developments have been configured in maritime communication networks, protocols, and techniques.

This paper tries to review the technological breakthroughs of the above-mentioned sectors through the timeline, ameliorations in maritime navigation till date under section 1, competent communication protocols and technologies in SAR under section 2, advanced communication techniques with the many underway R&D under section 3, and conclusions conferring to the perils associated with the evolving technologies under section 4.

## **SECTION 1. LATEST AMELIORATIONS IN MARITIME NAVIGATION**

There have been major technological breakthroughs in maritime navigation which have made it more reliable and have reduced the potential loss of lives, undue commercial costs, administrative burden, and damage to the environment. Through the ages, navigation has evolved from being a tedious process of observing nature and planning voyages by penciling lines onto charts to incorporating highly sophisticated electronic systems wherein all the information and data is computed and displayed on digital screens. About thousands of years before European expeditions, Polynesian navigators used their characteristic double-hulled canoes to navigate the entire Polynesian triangle relying purely on wayfinding techniques. The seafaring Europeans used the compass, astrolabe, sextants, and cross-staff as navigational aids to explore regions across the globe in the early 16th century. The introduction of the gyroscopic compass, radar, and radio at the beginning of the 20th century made navigation more systematic. However, it was the invention of GPS in the late 1970s that further revolutionized the field of marine navigation. Today, the most common navigation systems aboard a ship include a gyrocompass, echo sounders, radars, autopilot, speed logs, automatic radar plotting aids (ARPA), ECDIS, AIS, rudder angle indicator, navigation lights, daylight signaling lamps, and voyage planners. GPS is capable of determining location using direct signals from satellites which enable ships to navigate the vast oceans with greater precision and accuracy. Presently, operational satellite navigational systems such as GPS AND GLONASS along with several other regional satellites have combined under a single superset, the Global Navigation Satellite System (GNSS) making it an indispensable part of the position, navigation, and timing (PNT) systems. GNSS systems are further enhanced and augmented by integrating the information obtained from external sensors and performing calculations to improve the range, accuracy, availability, and reliability of the system. IMO's regulation for the carriage of Electronic Chart Display and Information System (ECDIS) was implemented in 2011 and this accelerated the technological advancements in marine navigation. ECDIS displays information from up-to-date Electronic Navigation Charts (ENCs) and is interfaced with other navigational sensors (radar, AIS, NAVTEX, echo sounders, ARPA) to give information about the position, heading and speed as well as carrying out automatic radar plotting on ENCs. It plays a huge role in carrying out a safe and economical voyage. Since there is a large influx of data from various sensors, ECDIS systems must be updated regularly to manage data efficiently.

Automatic Identification System (AIS) is a transponder system that has been introduced onboard ships to enhance existing radar systems. The information broadcasted over the VHF maritime band includes ship identification data, cargo type, course, and position to GPS accuracy and can be displayed on-screen or via an ecdis. In addition to AIS, VTS personnel also use radar, CCTV, and VHF radiotelephony for rapid calculation of CPA (Closest Point of Approach) and TCPA (Time to Closest Approach). AIS can also be integrated with Aid to Navigation (AtoN) devices such as lateral marks, lighthouses, and buoys to enable remote monitoring of the status of AtoNs using sensors to transmit the live data about sea state and weather conditions to the AIS transceivers on the vessel or the VTS providers. A significant breakthrough has been achieved about Virtual- AIS AtoN that can create an apparent AtoN on an electronic display. V-AIS AtoN can go to remote areas where a physical AtoN cannot be deployed. AIS on AtoNs depends on GNSS for knowledge on position and heading and hence would only work if GNSS as a whole works. Therefore, to address the vulnerabilities associated with the GNSS system, enhanced radar positioning was proposed, which is an automated process of determining the real-time accurate position by correlating a multitude of radar targets with a known position as a reference.

Automation with a focus on accurate navigation has emerged to be an area of active research. The autopilot system primarily uses a gyrocompass to control the heading of the ship to adhere to its course by minimizing rudder movement to reduce drag and thus lower fuel consumption. Modern autopilot systems can be synchronized with ECDIS to follow a set course and at the same time can be connected to other navigational sensors and use AI to perform automatic steering operations, thereby decreasing risks while also reducing the need for human intervention. Integrating AI and augmented reality has been picking up steam in the maritime industry. AR displays can be used to identify safe routes, navigational aids, and navigate congested seaways while AI technology can aid in the determination and generation of warnings against possible collisions and hence workload on personnel and optimize the navigation process.

## **SECTION 2. COMPETENT TECHNOLOGIES AND PROTOCOLS IN MARITIME SEARCH AND RESCUE**

Given the humanitarian nature of work, ensuring precautionary regulations and rendering of search and rescue services, defined under the international convention on maritime search and rescue (SAR Convention) to the persons in distress becomes an important aspect to be covered. Alerting and locating being the two key components in any SAR operation, should evolve in nature over time.

### **2.1. Unmanned technologies:**

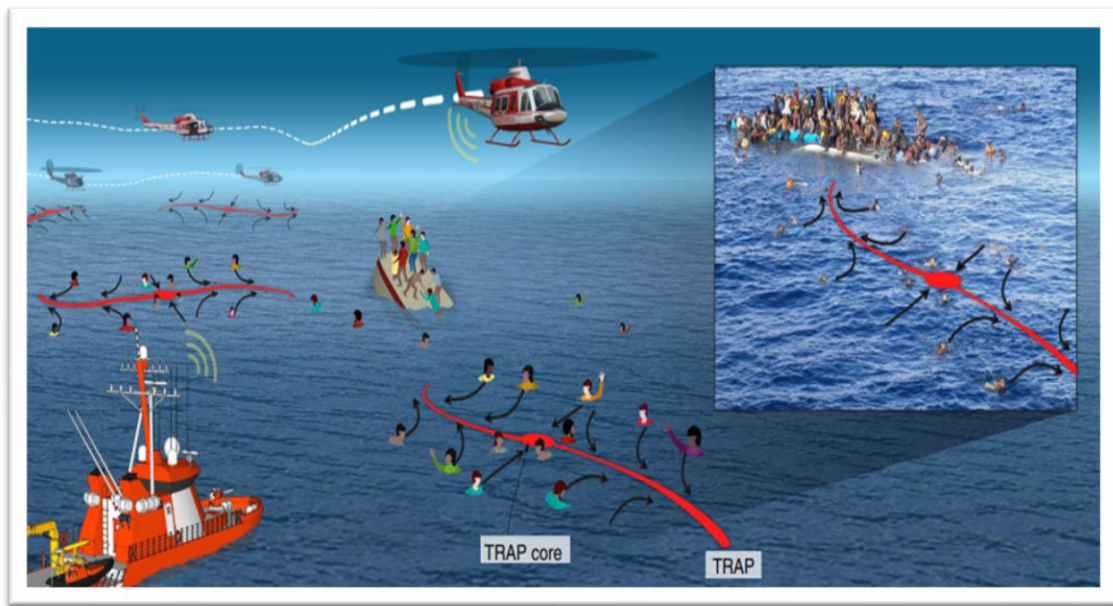
Today, when robotic assets have taken over maximally to the requirements, maritime operations also club together with unmanned practices for search and rescue operations at sea, given the need of ensuring the safety of the rescuers. The rescue time is a major factor as it holds direct proportionality with the survival rate. Manned rescues are often suspended because of external factors or circumstances such as lack of visibility or adverse atmospheric or marine conditions. But, to use a robotic device in such a circumstance is rational as it can still operate against the danger scenarios. First, a device such as a USV (Unmanned Surface Vehicle), equipped with camera and radar sensors for surface area control, sonar sensors for underwater control and other sensors for environmental control, and an additional autonomous behavioral payload, is capable to perform intelligence and surveillance operations. Second, UCAP (Unmanned Capsule) is a small-sized platform and carries along with it a life raft that can be inflated close to the victims, which is an able resource. Third, during a rescue operation, when the team receives an accurately predicted window of smooth sailing which could take about 45 seconds based on radar information, it launches a drone towards the search area. Within minutes of search, when the drone finds the target, a fast rescue boat and the mothership reaches for rescue. Hence, the unmanned robotic assets complement the traditional rescue practices and can take over once their relevance, development, and scalability improvements. Also, edging the variable technologies with artificial intelligence can make a bigger impact.

### **2.2. TRAP model:**

Existing SAR techniques involve integrating snapshots of the ocean velocity due to waves and currents to slowly generate an uncertain trajectory for locating where a missing person or object may have been carried, defined by the Lagrangian approach. They handle uncertain parameters in floating objects models as they average the Monte Carlo simulations to provide probability maps for locating the objects. The maps are usually difficult to interpret and

depict a slower convergence due to the underlying chaotic processes. It has been replaced by the Eulerian approach, a mathematical theory to uncover hidden attracting structures in highly unsteady flow data. This methodology uses the most reliable velocity forecast snapshots, close to the point where a missing person or object was last seen, and quickly uncovers the most attractive regions of the ocean at a given time.

These predictions get continuously computed and updated when the next batch of velocity information becomes available. These models are named TRAPs (TRansient Attracting Profiles), which are short-lived regions where water may converge and be likely to pull objects or people and are easily interpretable. It thereby yields a faster input for search asset allocation.



**Fig 1:** Sketch of a TRAP based SAR operation, Photo credit: Opielok Offshore Carrier

### 2.3.Vessel Triage:

All the communication protocols for distress signals are quite complex and demand the right understanding and highly trained and skilled man force to coordinate it. Vessel Triage is a simple and flexible communication method. The triage is not a substitute but an alongside implementation where the primary subject under consideration and observation is the vessel. It is a method that analyses the seaworthiness of the vessel based on the extent to which it can provide a safe environment for the people. Triage employs a color scheme and a concise description of the vessel which deploys simplicity, flexibility, and concise behavior for distress signals. The simplicity of the method eliminates the need for highly trained human resources for operating the system, flexibility brings in the provision of not sticking to a rigid protocol in SAR and related operations(generality). The concise behavior which is attained through a questionnaire would help in quick and effective communication with vessel crew and external personnel. The method identifies the ship in 4 different color categories as Green, Yellow, Red, and Black, each with a very general description and a few sub-cases. The table below depicts the color behavioral describes.

**Table 1:** Vessel TRIAGE categories, abridged from RAJA et al. (2015)

| COLOUR   | Green  | Yellow  | Red   | Black   |
|----------|--|---|---|---|
| DESCRIPT | The vessel is safe and can be assumed to remain so | The vessel is currently safe, but there is a risk that the situation will get worse | The level of safety has significantly worsened or will worsen and external actions are required to ensure the safety of people aboard | The vessel is no longer safe and has been lost. |

### SECTION 3. ADVANCED MARITIME COMMUNICATION TECHNIQUES

The early navigators tried to communicate by stimulating their elemental senses like auditory and visual systems through horns, bells, cannon firing, speaking trumpets, flares, and flags. However, the need of increasing the reach and efficiency led to the construction of lighthouses that aided in improving the visibility conditions to a radial extent of 20-30 miles; these elemental methods were employed even by the most modern navigators. Furthermore, the invention of electromagnets was vital to maritime communication as they paved the way for telegraphs so that 17th-century navigators started to talk in dots & dashes along with blinker lamps of morse code, and with time telegraphs attained their wireless version. The discovery of electromagnetic waves also led to the groundbreaking invention of semiconductors and this led to a connection revolution by deploying maritime communication networks (MCN). The 6 major classifications of MCN are island-based network (4G LTE network established in Rhode islands), vessel-based network (TRITON), sensing oriented maritime IoT systems (DARPA), satellite-based network including the satellite band: INMARSAT, O3b, Iridium, Tiantong-1, Shijian-13, Echostar-19 contributing to telephone & telegraph communication, the shore-based system spectrum of NAVTEX and the PACTOR series which brought OFDM (Orthogonal Frequency Division Multiplexing) into the picture and air-based network comprising of Internet.org by Facebook, Loon Project of Google, BLUECOM+.

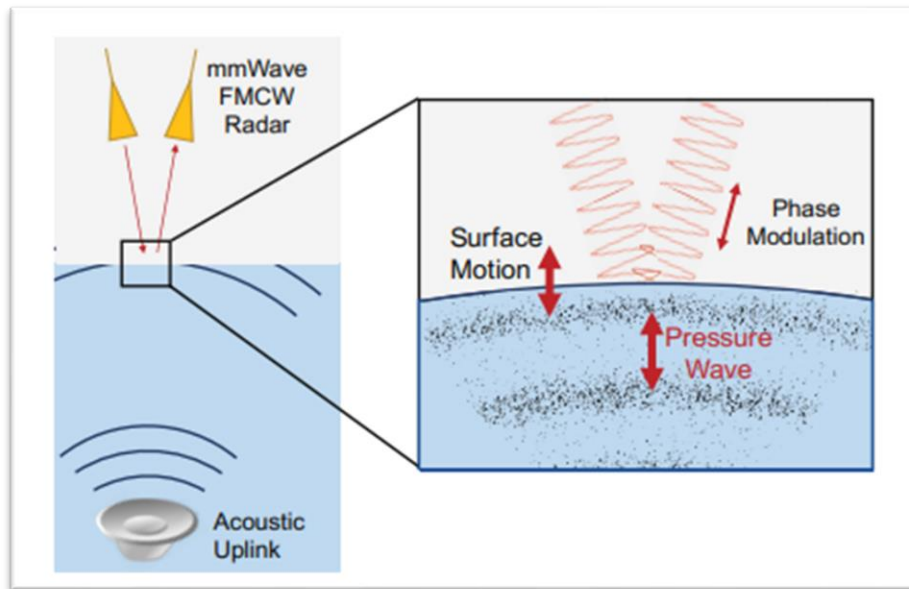
An internationally agreed safety procedure was adopted by IMO under SOLAS which is known as GMDSS (Global Maritime Distress and Safety System), a computer-driven satellite cum terrestrial radio-based system. The system replaced the legacy of Morse code's ship-to-ship nearby vicinity distress calls with ship-to-shore alerting systems. With its expansion, vessels were made capable of not only being able to transmit distress signals to the shore, usually a coast radio station or rescue coordination centre (RCC), but also receive radiocommunications in form of shore to ship distress alerts, on-scene and SAR coordinating communications, maritime safety information (MSI) and other general communications. At its inception, the suite of requirements was based on vessel tonnage but later was formulated on the vessel's intended routes' area and range. Four sea areas were identified.

- I. Sea area A1- Within radiotelephone coverage of at least one VHF (Very High Frequency) coast station equipped with continuous DSC (Digital Selective Calling) alerting (35 nautical miles).
- II. Sea area A2- Within the radiotelephone coverage of one MF (Medium Frequency) coast station equipped with continuous DSC alerting excluding sea area A1 (150-400 nautical miles).
- III. Sea area A3- Within the coverage of an INMARSAT geostationary satellite equipped with continuous alerting excluding sea areas A1 and A2.
- IV. Sea area A4- Excluding sea areas A1, A2, and A3, defines the range of polar waters. Ships operating must comply with HF-DSC communication and NBDP (Narrow Band Direct Printing) equipment.

Along with the primary tooling, satellite EPIRBs (Emergency Position Indicating Radio Beacon) are retrofitted for primary distress alerting and for receiving MSI. Provided the category of the relevance of MSI, ships have two kinds of systems NAVTEX, a terrestrial MF system, and SafetyNET, a satellite system, in form of smart printing radio receivers located on the bridge to accept or reject the particular communication. For vessel locating, a SART (Search and Rescue Transponder) plays the role of a signalman, transmitting and receiving radio signals and enabling quick detection with its bright color. Additionally, AIS transponders usually help with information on a ship's identity, for say, the call sign, Maritime Mobile Service Identity (MMSI), position, speed, course, etc. on the VHF band. With evolution, NAVTEX and AIS systems further advanced to corresponding NAVDAT (Navigational data) and VDES (VHF data exchange system) systems enabling a wider maritime data exchange, since, NAVTEX deployed low data rates which could not suffice the possibilities of advanced route mechanism and AIS posed channel congestion along with efficiency degradation. It resulted in scope for parallel modernization of the GMDSS and supported the development of the maritime cloud, also improving SAR operation efficiencies.

A band apart, underwater communication has also witnessed an evolution similar to surface communication. The 4 methodologies of UWC were acoustic, optical, electromagnetic, and most recently magnetic field communication. As evident from the name, while all others were waves, the latter is a field. A field brings along its characteristic advantages over waves. It is a non-propagating and instantly created entity with no multipath and doppler effect. All kinds of electromagnetic waves suffer from severe attenuation in water because of significant differences in electric relative permeability, but in MF communication the relative magnetic permeability is similar resulting in the same communication range. It offers immunity to underwater channel response and minimum transmission delay. Besides, the small radiation resistance of the coil offers a predictable and stable channel with no transmission delay. Additionally, underwater wireless power transfer using magnetic fields can be used to recharge battery-powered vessels like AUV and ROVs, the implementation cost also being low. The effectiveness can be improved by increasing the number of coils, using multidimensional coils, metamaterial enhanced antennas, SCENL, polyhedral geometry, and by finding a matching network that resonates with the field. It is noteworthy that there are major and dramatic design and protocol advancements in the MF communication system. Information transfer between underwater channels and air-borne receivers or surface-based receivers via electromagnetic waves experiences exponential attenuation and absorption inside the water. In this scenario, acoustic waves inside water are considered but this gear is reflected at the surface and the line remains uncrossable. TARF (Transitional Acoustic Radio Frequency) is a novel technology invented to transfer information across the interphase, the existing technologies being incompetent. Proposed methodologies, currently underway R&D are discussed under two sections. First, from the underwater source to the water surface and second, from the surface

to the airborne receiver. When an acoustic wave is produced from an underwater node it travels and hits the water surface. The wave nature being mechanical, transfer pressure to the surface and cause impingements causing minute ripples. Using a radio transmitter in an airborne drone or similar stations, a radio frequency reflection could be obtained and message decoding. The technique has undergone two-level evaluation in calm and shallow waters, a swimming pool, and has shown unprecedented results of transferring data via the interface. There are a few major drawbacks of the method which are to be addressed, which would lead to TARF being a major advancement in maritime communication via the air-water interface.



**Fig 2.** The phase of wireless reflection changing with minute surface vibrations, Credit- Networking across boundaries, SIGCOMM, 2018

## CONCLUSION:

Technological enhancements in form of cyber-physical systems have brought about a profound change in the shipping sector that is today facing stricter regulatory measures regarding energy efficiency and environmentally safe operations. The improving array of technological breakthroughs on the world stage is expected to be highly disruptive but there are mounting concerns that these technologies will pose serious challenges. From the above discussion, it's clear that the whole bunch of Neo-technology has taken their shape around the core of sophisticated software systems, which are very much vulnerable to attacks in cyberspace. Technological advancements will not suffice as a replacement for humans and therefore we suggest a mandatory thorough ship-specific and hostile cyber breach scenario-based training for the workforce to develop their quick response and defense strategies in the face of evolving threats. We, therefore, envision risk management strategies to involve encryption of sensitive data using cryptographic techniques and conduction of regular cyber security assessments that can help mitigate all forms of cyber-attacks.

## REFERENCES:

- [1] Burmeister, H.-C., et al., Autonomous unmanned merchant vessel and its contribution towards the e-Navigation implementation: The MUNIN perspective. *International Journal of e-Navigation and Maritime Economy* (2014)
- [2] Francesco Tololini and Fadel Adib, Networking across boundaries: Enabling wireless communication through the water-air interface, MIT Media lab, SIGCOMM'18, (2018)
- [3] Jori Nordstron, Vessel TRIAGE: A method for assessing and communicating the safety status of vessels in maritime distress situations, ELSEVIER, *Safety Science* (2016)
- [4] Laurie Tetley, David Calcutt, *Electronic Navigation Systems*, 3<sup>rd</sup> Edition, Butterworth-Heinemann Ltd (2001)
- [5] Mattia Serra, Pratik Sathe, Irina Rypina, Anthony Kirincich, Shane D. Ross, Pierre Lermusiaux, Arthur Allen, Thomas Peacock & George Haller, Search and rescue at sea aided by hidden flow structures (2020)
- [6] Muhammad Muzzamil, Fundamental and advancements of magnetic-field communication for underwater wireless sensor networks, *IEEE transactions on antennas and propagation*, Vol 68 (2020)
- [7] Sarkodie Pokuaa Andriana, Zhang Zhenkai, Benuwa Ben-Bright, Benjamin Ghansah, Ernest Ansah, *A Survey of Advanced Marine Communication and Navigation Technologies: Developments and Strategies* (2018)
- [8] Te Wei, Hybrid Terrestrial communication networks for the maritime internet of things: Key technologies, opportunities, and challenges, *IEEE* (2021)
- [9] IALA-AISM, *Navguide- Aids to Navigation Manual*, 7th edition (2014)
- [10] MAIB and DMAIB, *Application and usability of ECDIS safety study* (2021)

# Technical Write-ups for Models

## PORTABLE RESCUE BOAT

Cdt Ujjwal Gehlot<sup>a</sup>,

Tolani Maritime Institute

ujjwal.gehlot2019me@gmail.com

Cdt Fewan Leezer Dsouza<sup>b</sup>,

Tolani Maritime Institute

fewan.dsouza2019me@gmail.com

Cdt Vaishak R<sup>c</sup>

Tolani Maritime Institute

vaishak.r2019me@gmail.com

Cdt Ayush Soni<sup>d</sup>

Tolani Maritime Institute

ayush.soni2019me@gmail.com

### Abstract

Man overboard is a situation where a crew member or a passenger has fallen off the ship into the water and is in need of immediate rescue. After a very short time in cold water, even a fit conscious person will have lost considerable strength and agility and will need help to get aboard, especially in heavy wet clothing. The condition of a person in the early stages of hypothermia can be made considerably worse. The traditional manoeuvre is more time consuming and requires more sailing skill. As the person will be in panic state, a lifebuoy is thrown to him immediately for rescue which sometime fails to reach him. In any given month, approximately two people go overboard and between 17 percent to 25 percent are rescued. So, we have come up with an innovative model to solve this issue.

### Objectives

- \*The overboard person can be rescued faster than the traditional method
- \*The risk of man driving the traditional rescue boat is reduced, as our model is remote controlled
- \*The lifebuoy is made easily accessible to the person overboard

### Introduction

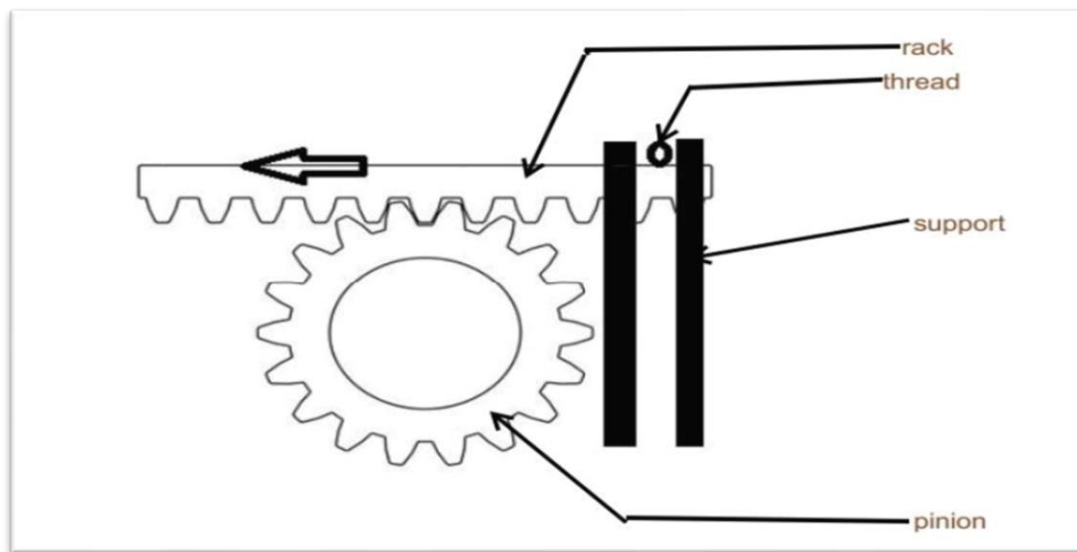
A portable rescue boat is a remote-controlled boat which can be lowered and moved easily, unlike the regular rescue boats. The portable rescue boat consists of various mechanism to rescue the person. It contains lifebuoy which the boat will carry near the person overboard, so it becomes easy for the person to grab it. There is a GPS installed in these portable rescue boats and lifebuoys during their manufacturing. With the help of this GPS, we can track down the accurate location of the man-over-board even in rough weather conditions too. There are emergency lights attached on the rescue boat, if a man-over-board situation occurs at night/dark. The rescue boat is designed in such a way that it can be lowered easily by a single person too.

## Working

When the person falls overboard, man overboard alarm is raised. we throw the portable rescue boat into the sea directly. the rescue boat is light enough that even a single person can lower it. The boat is controlled using the transmitter remote by staying on the ship itself eliminating the manual driver on the boat. The lifebuoy is fixed to the rescue boat using an electromagnet. It will get detached and will be thrown into the water near the person. This detaching is done when the signal through the transmitter is given to the receiver on boat. A rope will be attached to lifebuoy and another end of the rope is attached to the rescue boat using a rack and pinion mechanism, so this mechanism helps the lifebuoy to detach from the boat when the person is taken onboard.

### The working of the detachment mechanism:

The portable rescue boat consists of a receiver unit which is powered by a 12V lithium-ion battery. When the receiver receives the signal the motor connected to the receiver unit rotates, the pin which it attached to the motor will move back and the rope connected to the lifebuoy will be detached from the rescue boat. We can also use a rack and pinion mechanism as shown in the figure.



**Figure 1.** Mechanism for the detachment of the lifebuoy

### Components:

#### Body:

The body of the portable rescue boat is made up of fiberglass which is light and has good strength. The fiberglass is hard which will make the body rigid to survive the waves in bad weather.

#### For the propulsion- high torque brushless motor:

For propulsion we are using 24V high torque brushless motor with a gear box. Brushless motors are more efficient as these motors can control continuously at maximum rotational force

(torque) and require less maintenance than the normal dc motors. BLDC motors can be controlled, using feedback mechanisms, to delivery precisely the desired torque and rotation speed.

**Electromagnets:**

We use an electromagnet to attach the lifebuoy to the boat and the current to the electromagnet is controlled by the transmitter.

Electromagnets are also used to take the boat onboard again after the rescue. The top of the boat is fitted with a thin steel plate, the electromagnet attached to the rope is dropped from the ship sticks to the boat in the water and then the boat is brought onboard.

**GPS:**

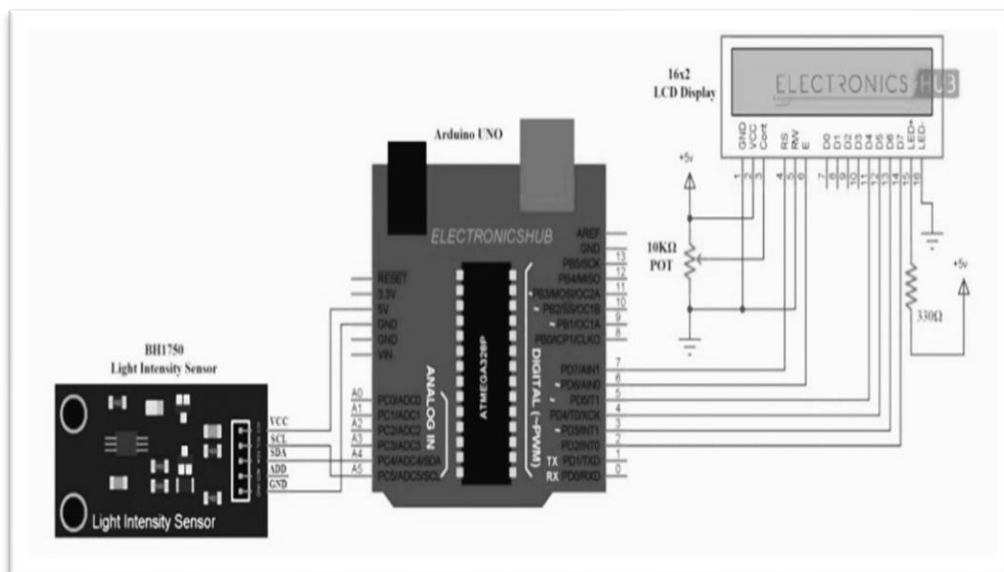
The GPS is fitted inside the the portable rescue boat and lifebuoy so the exact location of the rescue boat and the lifebuoy worn by the person is detected. The GPS sensor which we are using is mini GPS tracker

**Lights:**

In order to locate the rescue boat more accurate we use the red flashing lights on both the sides of boat with effective luminous intensity. The lights which we use shouldn't be extinguished by water.

**Light intensity sensor:**

The lights on the boat are controlled by the light intensity sensors so it will not consume the power during daylight and when it is dark this sensor senses, then the lights will start glowing.



**Figure 2.** Circuit diagram for the light intensity sensor.

### Solar panel:

In some situations, if the battery fails the GPS and lights will consume the power from the solar panel so we can still locate the rescue boat with that.

### Transmitter and receiver:

We are using a 2.4Ghz transmitter and receiver. The range of this transmitter and receiver is around 2 to 3km. So, we can easily operate our portable rescue boat in that range and the range can be increased by increasing the gain of the antenna or by increasing the frequency.

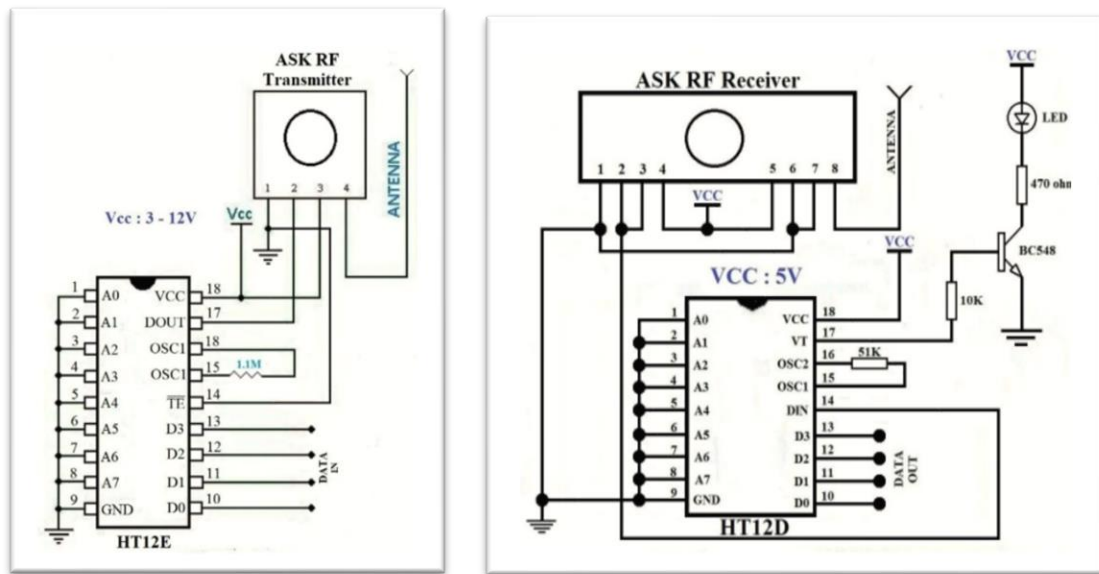


Figure 3. Circuit diagram for the transmitter and receiver unit.

### GRAPH:

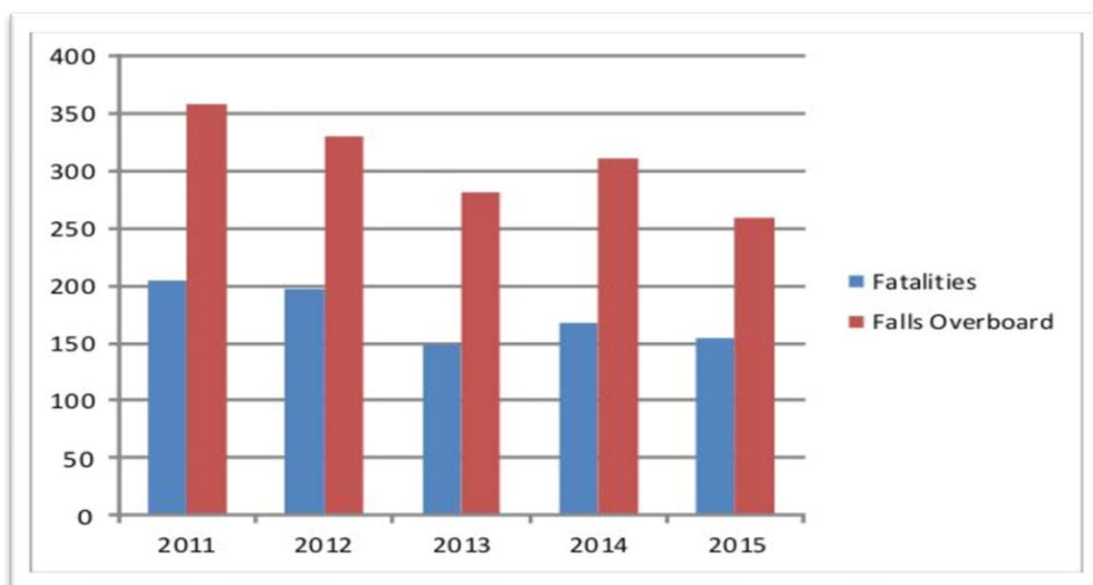


Figure 4. Graph for the number of person fall overboard in the following years.

**Conclusion:**

Therefore, based on the above-mentioned facts and statistics we see the traditional method used is not much effective as around 55% of people have died after falling overboard. So, if the model proposed by us is used during this emergency, the time between the man overboard detected to the person rescued is reduced to an extreme extent, hence the chances of saving the lives of crew/passengers overboard are increased. As our proposed model is light in weight, it can be operated by a single person and it can also be effectively used even during the night time.

**REFERANCE:**

1. <http://marine.the-justgroup.com/man-overboard-statistics/>
2. [https://en.wikipedia.org/wiki/Man\\_overboard2](https://en.wikipedia.org/wiki/Man_overboard2)
3. <https://www.electronicshub.org/bh1750-ambient-light-sensor/>

# **FIRE FIGHTING ROBOT WITH GAS DETECTION SYSTEM**

Cdt. Hardik Vats<sup>a</sup>

Tolani Maritime Institute Induri, India  
hardikvats22@gmail.com

Cdt. Jatin Pandey<sup>b</sup>

Tolani Maritime Institute Induri, India  
jatin.pandey2019me@gmail.com

Cdt. Piyush Sah<sup>c</sup>,

Tolani Maritime Institute Induri, India  
piyush.sah2019me@gmail.com

Cdt. Anurag Dubey<sup>d</sup>

Tolani Maritime Institute Induri, India  
anurag.dubey2019me@gmail.com

## **I. ABSTRACT**

Ship is a potential fire hazard and fire incidents are very frequent to hear in this industry. Firefighting responsibility lies on the shoulders of the seafarers working on ships, unfortunately sometimes during firefighting costs a loss of a valuable life. Even injuries sustained during firefighting leaves a chronic effect on the human body.

On the same hand Enclosed space entry is considered to be a dangerous task on board, and incidents related to it costed 145 life's in the past 20 years there is a 28% rise in enclosed space incidents per Anum. This alarming situation seeks for an alternative system which first ensure the safe working conditions in the enclosed space and can be used as firefighting system in case of fire.

## **II. OBJECTIVE**

The following are the objectives of our proposed model:

1. To reduce the loss of life in firefighting.
2. To ensure enclosed spaces are safe to be accessed.
3. To accurately provide atmosphere details in an enclosed space or the space after firefighting so that it is safe for personal to access that space.

## **III. PRINCIPLE/ CONCEPT**

Our model is precisely based on Artificial Intelligence and Internet of Things (IoT). We plan to minimize the risk involved in firefighting and entering an enclosed space or space after the fire hazard with our proposed model, we aim to ensure utmost safety to crew working onboard in case of any fire emergency in battery room, Paint locker, Chain Locker, Pump room, etc. This robot will be capable of firefighting with the live monitoring about the conditions which includes temperature, Flame Presence & Concentration of gases in the space.

This Model is capable of pumping water as an extinguishing medium till the time normal parameters are achieved in the respective space. By monitoring the parameters transmitted by the robot crew can plan their next course of action proactively. This model is controlled by a Bluetooth module (Short Range) but a radio-controlled module can be used. This Robot works on the principle of DETECT, INFORM & EXTINGUISH.

#### **IV. EQUIPMENT WITH SPECIFICATION USED FOR MODEL**

1. Arduino Uno R3
2. Arduino Uno Shield
3. Flame Sensor
4. L298N motor drive Module
5. Chassis
6. 2 Motors (45 RPM)
7. 5V Submersible Pump
8. 12V Rechargeable Battery
9. 9V Battery
10. MQ-135 Air Quality Sensor

#### **V. OBJECTIVE**

Our proposed model is designed for the spaces on the weather deck like Battery room & Paint locker for easy access. We plan to navigate the robot inside these compartments and robot will start sensing the atmosphere inside the compartment and transmits the parameters to the crew. Robot is fixed with a gas detector and an IR sensor which can sense presence of any toxic gas and presence of flame. In case any flame is detected the signal will notify the controller and it will start the submersible pump to spray the water towards the flame till the time flame is completely contained (We have taken the case of class A fire).

This Model can be used in places where fire detectors and extinguishing systems are not present. This will maintain a good distance between crew and fire and crew can plan their actions as per the inputs send by the Robot.

We can consider the case of fire during bunkering operation where this model can detect the first sparks immediately and alarm the crew about it followed by extinguishing. Though it may not be able to suppress it fully but can provide enough time to the crew to go to safe distance and start extinguishing fire safely. This goes with the incidents in the mooring stations especially in the proximity of Anchor Winches.

#### **VI. INTRODUCTION**

In our proposed model we have used Arduino controller as the control unit as it takes the input from sensors like IR sensor, Gas detection sensor & Temperature sensor. Robot is moved by the motor driver and input is fed from the Arduino as per the commands given by used to the Bluetooth module. Data is sent back to the user via Bluetooth module and it offers live monitoring of data and early detection on any hazard. This robot has the capability to extinguish small Class A fires via the means of submersible pump and jet system. The main idea behind this robot is to minimize the human presence in dangerous environment like enclosed space to avoid any loss of life. This robot can be used as a monitoring device before enclosed space entry so that toxic gases can be avoided fully by the crew and avoid any health issues. Our proposed model promises maximum crew safety and early alarming so that arrangements can be made to tackle the emergency in the early stages.

## VII. CONCEPT

### a. Arduino Sensor Shield V5: [1]

Arduino Sensor Shield is a low-cost board on which different outputs from the sensors can be attached to Arduino using easy-to-attach jumper cables. We can easily connect with usual analog sensors by using this expansion board, such as temperature sensor, Flame sensor, Gas Detector, etc. The 3-way male connectors allow you to connect servo motors. All the components are designed to be Arduino UNO compatible. It reads the data from the sensors and send it to the control unit which makes the decision according to the set parameters.

### b. HC 05 Bluetooth module [2]

This module enables to communicate wirelessly with the Arduino controller. This module consists of Command mode where command is given to the controller, and it relays the information sent by the user. The other mode is Data Mode in which information is shared between the component and the user.

### c. Flame Sensor & L298N Motor Driver [3]

A flame sensor module that consists of a flame sensor (IR receiver), resistor, capacitor, potentiometer, and comparator LM393 in an integrated circuit. It can detect infrared light with a wavelength ranging from 700nm to 1000nm. The far-infrared flame probe converts the light detected in the form of infrared light into current changes. Sensitivity is adjusted through the onboard variable resistor with a detection angle of 60 degrees.

### d. L298N Motor driver

The L298N is a dual H-Bridge motor driver which allows speed and direction control of two DC motors at the same time. The module can drive DC motors that have voltages between 5 and 35V, with a peak current up to 2A. The module has two screw terminal blocks for the motor A and B, and another screw terminal block for the Ground pin, the VCC for motor and a 5V pin which can either be an input or output. Working voltage is between 3.3v and 5.2v DC, with a digital output to indicate the presence of a signal. Sensing is conditioned by an LM393 comparator.

### e. Submersible Pump

Submersible Pump is connected to L298 motor driver and Arduino controller via a single module relay controller. As flame is confirmed by the IR sensor module the Arduino controller sends the signal to switch on the pump motor via the Motor driver

f. **MQ-135 Sensor:** This sensor senses like Ammonia, Nitrogen, Alcohols, Aromatic Compounds, Sulfide & smoke. It has the potential to detect different harmful gases and uses 5 V supply for working and connected to Arduino.

## VIII. WORKING PRINCIPLE:

The main brain of this project is the Arduino, but in-order to sense fire we use the Fire sensor module (flame sensor). • When fire burns it emits a small amount of Infra-red light, this light will be received by the IR receiver on the sensor module. • So, we place three such sensors in three directions of the robot to sense on which direction the fire is burning. We detect the direction of the fire we can use the motors to move near the fire by driving our motors through the L293D module. When near a fire we have to put it out using water. Using a small container we can carry water, a 5V pump is also placed in the container and the whole container is placed on top of a servo motor so that we can control the direction in which the water has to be sprayed.

## **IX. CONSTRUCTION DETAILS**

As depicted in detailed circuit diagram, different components i.e., 12V Rechargeable battery, 9V battery, L298N motor drive, flame sensor, Arduino Uno Sensor shield, Arduino UNO, Relay, Pump motor, HC-05 Module, Motor drive are used to build a firefighting robot using Arduino, which will automatically sense the fire and start the water pump.

A 12v/2.5A DC battery, positive and negative supplies are taken out, all supplies are connected at Pushed-ON switch, then comes at thimble, two regulators are connected, taking grounds same for both regulators, giving 5V supplies, then MQ-135 sensor, 5V ground, analog pin voltage supplies are taken out (one pin for digital voltage supplies are not used here), second sensor i.e., flame sensor are used where supplies 5V, ground, digital voltage pin are taken out (one pin of analog digital supplies are used), to operate Relay

Then Arduino are used, and L298N motor drive are used, 12V, ground, 5v connections are taken out, and supplies of 12V, ground, 5V of regulators are connected, ground connections are made common for all connections. 5V Supplies are used for sensors and 12V supplies are used for L298N motor drive.

A Relay Module is placed, and connected with 5V connections, and ground is common for all connections, and output of relay is connected at D7 pin of Arduino. A pump is used, which requires 12V supplies and grounding is done. Once flame sensor gives signal to Arduino, Arduino provides it to Relay Module which makes pump to start.

A Bluetooth Module (HC-05) connected with 5V supplies, Arduino is also connected with regulator, and grounding is made common for all connection. Tx of HC-05 (Bluetooth Module) is connected with Rx of Arduino, & Rx of HC-05 is connected with Tx of Arduino, then communication happens. Four output of Arduino comes out, connected with L293D motor drive, which is connected with two 100 rpm DC motors.

Logic being used are as follows:

1010- Forward movement

0101- Backward movement

1001- Left movement

0110- Right movement

1111- Movement stops

These are commands provided by Bluetooth device for movement of Fire-Fighting Ro

## X. DETAILED DIAGRAM

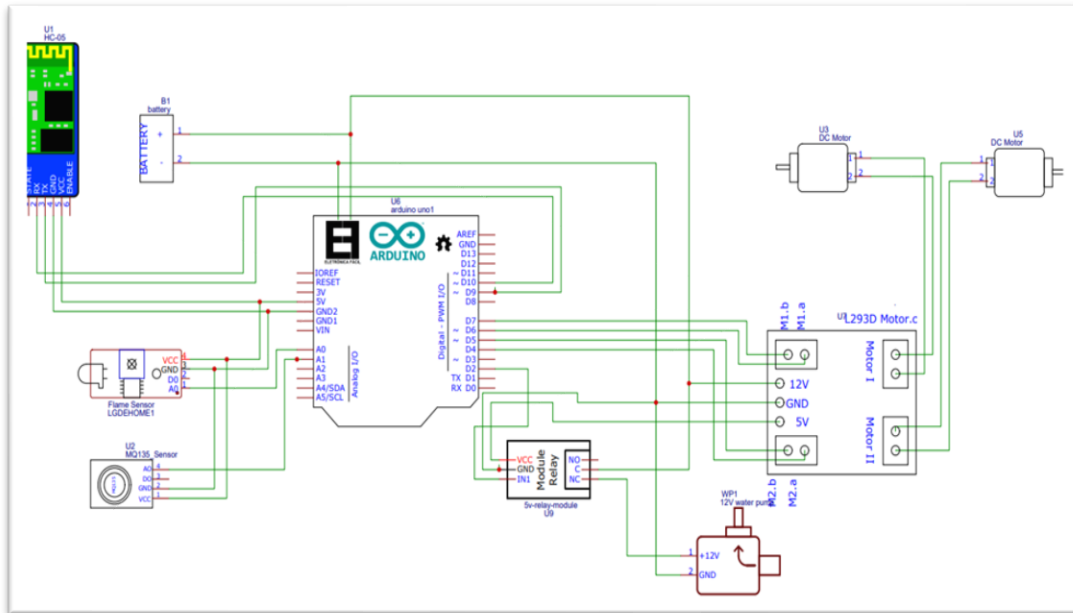


Figure 1: Circuit Diagram

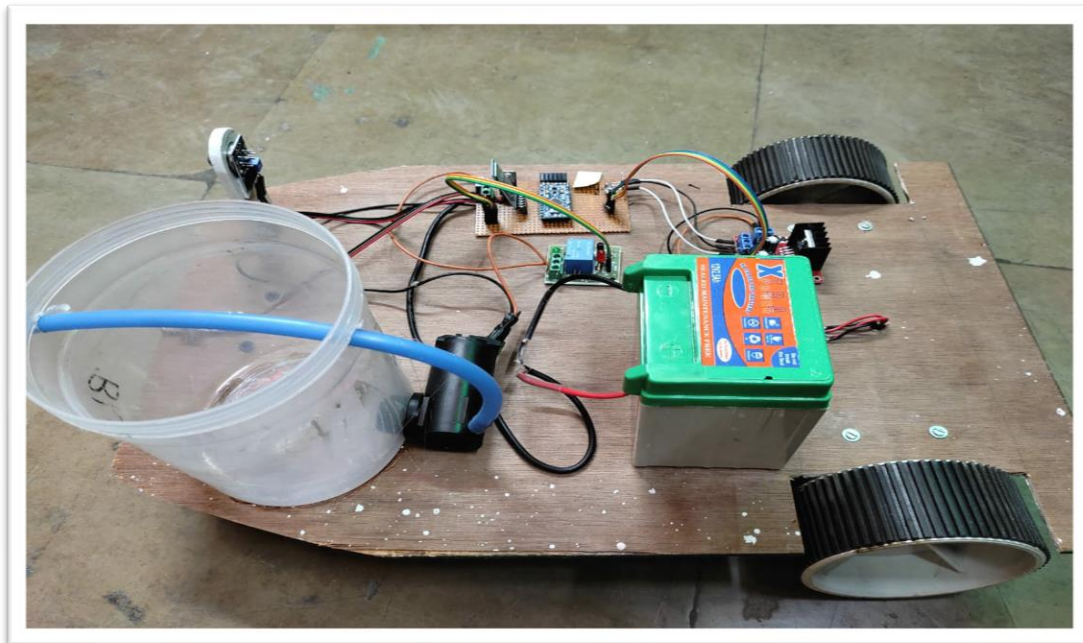
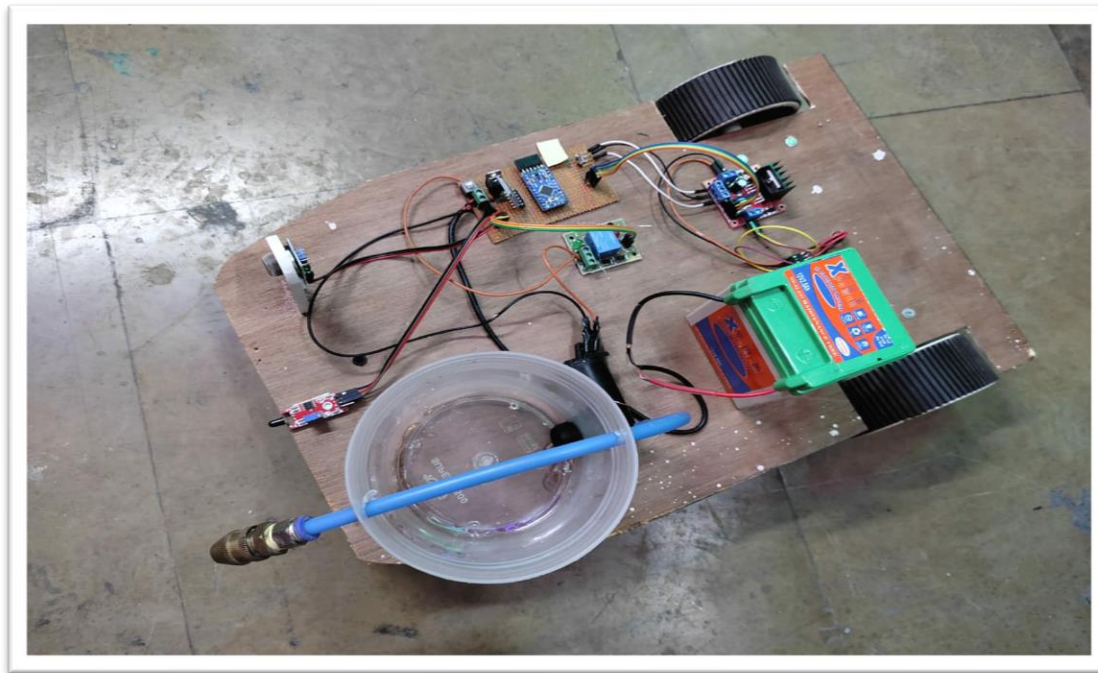


Figure 2: Side View of Model



**Figure 3:** *Top View of Model*

## **XI. RESULTS**

This model is tested in the controlled conditions where a flame was excited with the external source (Matchstick) and IR Sensor the flame and signals the submersible pump to spray water at the flame till the IR sensor gives the NIL output and pump stops.

Table 1: Test Performed

| S.NO | Distance Of flame From Model | Time Required to Extinguish |
|------|------------------------------|-----------------------------|
| 1.   | 1.5m                         | 5s                          |
| 2.   | 2.5m                         | 8s                          |

## **XII. conclusion & Future studies**

With our proposed model we are focusing on reducing the human interaction in case of any fire emergency and reducing the risk of life while entering the enclosed space. Our model is expected to deliver the following results:

1. Minimize the human interaction during fire emergencies.
2. Better monitoring of enclosed spaces and ensuring safe working conditions.
3. Real time tracking and monitoring of the environment and alarming in the initial stages regardless of the conventional systems.
4. Automate the firefighting system.

This model focuses on minimizing the human interaction during firefighting and providing time for the crew in case of any emergency on board. Though, this was a prototype model and subjected to future modifications to yield fruitful results.

Following few modifications can be adopted:

1. Robot motion to be controlled by the IR sensor and temperature sensor so that it is positioned at the correct position to safeguard itself and continue firefighting.
2. Fire Hose can be fitted to the robot for advance firefighting operations, thus zeroing the human presence.
3. Camera can be Mounted on the robot so that a live feed is available at the crew and this information can be used in future for study and research purposes.
4. For long Range Control we can use radio wave control instead of Bluetooth communications

## **IX REFERENCES**

[1] [www.arduino.com /Library/Device Control](http://www.arduino.com/Library/Device%20Control).

[2] HC-05 Serial Bluetooth Module - Tutorial ([electrosome.com](http://electrosome.com))

[3] L298N Motor Driver Module Pinout, Datasheet, Features & Specs ([components101.com](http://components101.com))

# SAFETY AND EFFICIENCY IMPROVING TECHNOLOGIES IN AUTONOMOUS SHIPS

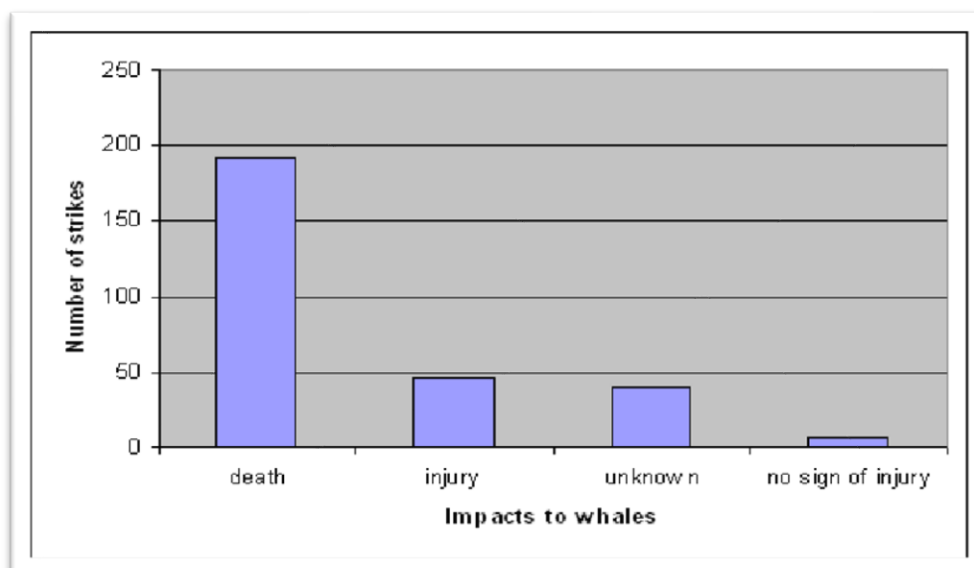
Bhavesh Kumar Sendh<sup>a</sup>  
<sup>a</sup>Tolani Maritime Institute  
bhavesh.sendh2020me@gmail.com

Darshan Patidar<sup>b</sup>  
<sup>b</sup>Tolani Maritime Institute  
darshan.patidar2020me@gmail.com

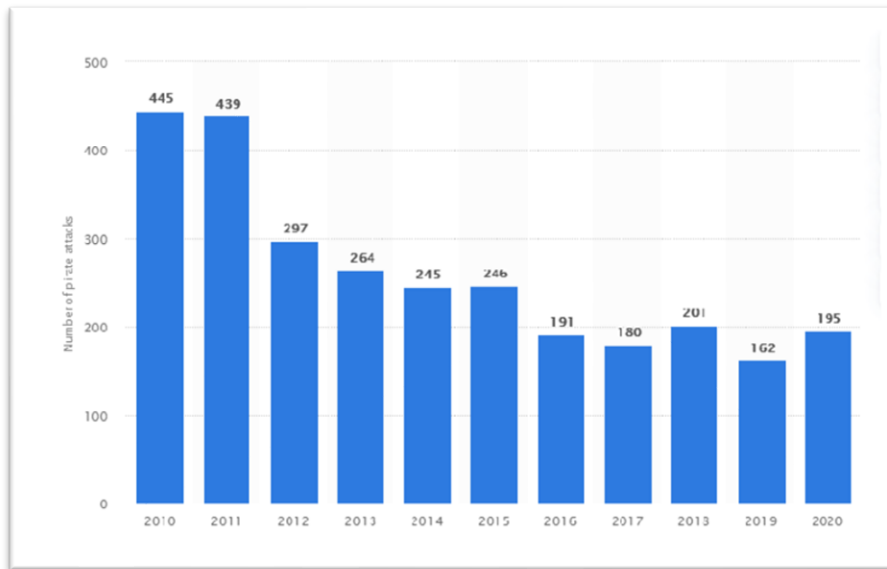
## I. ABSTRACT

Industry 4.0 is revolutionizing the way shipping companies manufacture, ameliorate and spread their products. It's no longer a dream to see crewless ships running all around the globe. SVAN (Safer Vessel with Autonomous Ferry) collaboration of Rolls Royce and Finferries have successfully demonstrated fully autonomous ship. They have achieved by using artificial intelligence, advanced sensors, autonomous navigation and many more. But, the safety of the goods carried by the vessel, safety of marine mammals and power saving is rarely mentioned. Piracy is still practised at sea. We cannot ignore piracy at sea in search of automation in shipping industry. Crewless ship would be a golden opportunity for pirates to do their work fearlessly. Graph of number of pirate attack from year 2010 to2020 is given in Fig.2. The danger to whales and other large marine mammals from ocean going vessels' propellers and bows has long been recognized. Ship strikes kill more than 20,000 whales every year. This an alarming number, especially considering how close to extinction some whale species already are. The New York State Marine Mammal and Sea Turtle Stranding Program revealed that 10.6% of all turtles exhibited evidence of propeller wounds.

Efficiency is also a matter of concern in autonomous ship. The conventional rudder which is installed in maximum ships for manoeuvring, itself reduces efficiency of the ship. It increases ship resistance as a bulky attachment to the hull, its turning angle is also limited to 35 degrees which limits manoeuvrability. Considering the above challenges this model is made to sort out all the above challenges faced by autonomous ships.



**Fig.1:** Result of ship strike to large whales.



**Fig.2:** Number of pirate attack from year 2010 to2020

## II. KEY-WORDS

Anti-piracy system, marine mammal safety system, twin rudder system, automatic navigation lights system.

## III. OBJECTIVE

The objective of this working model is to set up a safety system for goods carried by autonomous ships, to avoid collision of autonomous ship and marine mammals and to increase fuel efficiency by installing a new type of rudder.

## IV. INTRODUCTION

The model consists of four systems. Those are as follows:

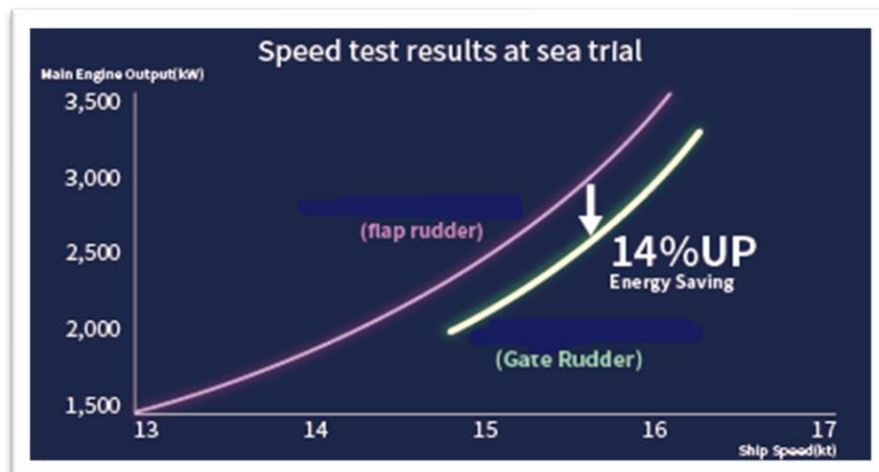
- Anti piracy system-  
This system is installed to prevent boarding of pirates on autonomous crewless ships. This system is made using microcontroller, sensors, and water canons.
- Marine mammals safety system-  
Large whales need to come to the surface of water in every 30 minutes to breathe. These marine mammals see a limited amount of colours like red and yellow light is absorbed by water. This makes most objects underwater appear bluish-green. Due to this poor vision, it becomes difficult for whales to see the floating ships which results in collision. Collision with propeller causes severe cuts on whale's body which sometimes leads to death. Marine mammal safety system is installed to prevent the collision of ship and marine mammals. This system uses microcontroller, sensors and water pump.



**Fig.3:** Severe cuts on whale body after collision with ship's propeller

- Twin rudder system-

The twin rudder system is quite different from the existing conventional rudders. This new type of steering technology reduces resistance of rudder and create thrust to save fuel consumption of 14%. The turning circle of gate rudder is comparatively smaller than that of conventional flap rudder. Further, the propulsive efficiency is increased due to the accelerated duct flow, the rotatable twin rudder system provides extremely high turning performance at slow speed, meets IMO standards at maximum speed and improves seakeeping ability. It also saves around 5-6 % of propulsion power.



**Fig.4:** Energy saving by Gate rudder system

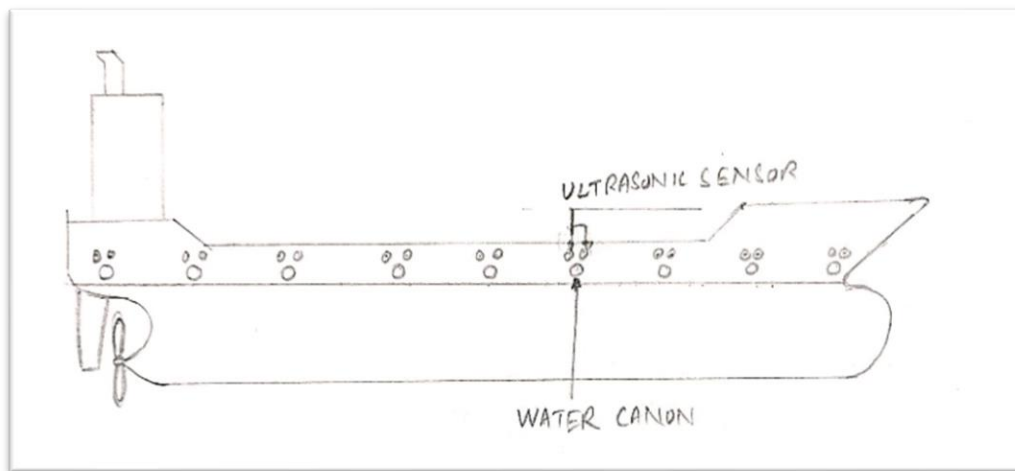
- Automatic navigation lights system-

When a ship is sailing in open sea at night, the navigation lights should be on all the time. It is used to give signals to the oncoming vessel that whether the vessel is at anchor or not, which side of the ship is seen, etc. These lights prevent collision of ships at night. This system turns on navigation lights automatically at night and turns it off during day time.

## V. CONCEPT

### Anti-piracy system

Many ultrasonic sensors and water canons will be attached in the freeboard of the ship at a certain level. The ultrasonic sensor will detect if any solid object is near the ship or not. The readings of the ultrasonic sensor will be seen from the port. The sensor will show a constant distance i.e. maximum range of the sensor when no solid object is in front of it. If the reading changes then we will get to know that a boat is near the ship. The sensor will give us the distance between the pirate's boat and our ship. A 'water cannon on distance' will be set on the ultrasonic sensor that if the distance between pirate's boat and our ship becomes less than water cannon on distance then the water cannon above the sensor will turn on and throw high pressure water to the pirate's boat. It will turn off if the distance between pirate's boat and our ship becomes greater than water cannon on distance. This will prevent coming of any solid object such as pirate's boat to come near the ship from any direction. The water cannon on distance can be controlled from port. We can reduce the 'water cannon on distance' if the ship is passing through a narrow canal. It can also be turned off when the ship is near any port. If any non piracy boat wants to come near the ship such as tug boat then it would need to take the permit from the ship's company. If it gets the permit then the sensors can be turned off for some time. The water canon will throw seawater when turned on as it can be used unlimiteadly and it will also not affect marine life. This will prevent pirates to come near the crewless ship, so the goods will be carried safely in the sea.



**Fig.5:** *Ultrasonic sensors and water cannon attached in freeboard*

### Marine mammals safety system

A ultrasonic sensor will be attached at the hull near the propeller. The ultrasonic sensor will detect marine mammals near the ship. The readings of the ultrasonic sensor will be seen from the port. The sensor will show a constant distance i.e. maximum range of the sensor when no solid object is in front of it. If the reading changes then we will get to know that a whale or other marine mammal is near the ship. When any whale will come near the ship the speed of the propeller will reduce and the water sprinkler attached at the bottom of the hull will sprinkle water on the whale so that the whale will go away from the ship. Still if it continues to come

near the propeller then the propeller will stop. Collision of whale with stationary propeller will not cause any severe cuts to the whale and the whale will be safe. The propeller will automatically start after the whale goes away from the ship. The water sprinkler will also stop once the whale is gone. This way marine mammals will be safe from autonomous ship.

#### Twin rudder

Due to its asymmetric cross-section it works on a different principle than the present existing types of rudder. The major advantage of the twin rudder system stems from the duct effect generated from the working propeller. By placing two asymmetric uniquely shaped rudders placed in parallel at each side of a propeller instead of placing behind the propeller, the rudders and the propeller are able to function like a ducted propeller.

#### Automatic navigation lights system

A light dependent register (LDR) circuit is installed with the navigation lights. After sunset the navigation lights will turn on automatically. The lights will turn off automatically when sunlight hits LDR.

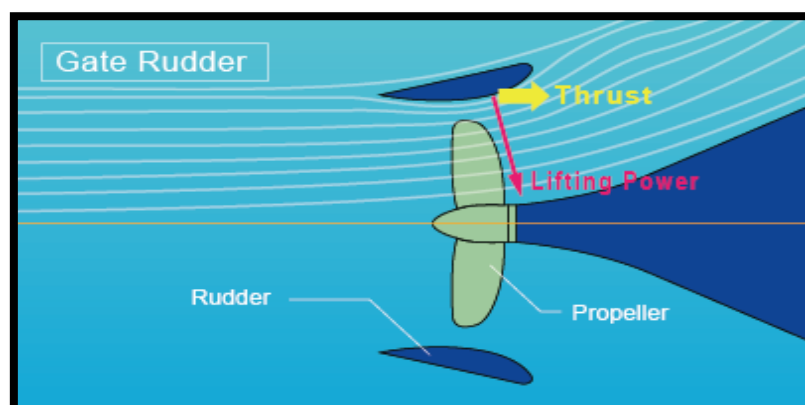
## VI. WORKING PRINCIPLE

#### Anti-piracy system and marine mammals safety system

The anti-piracy system and marine mammals safety system will consist of ultrasonic sensor, arduino uno, and water pump. Ultrasonic sensors emit short, high-frequency sound pulses at regular intervals. These propagate in the air at the velocity of sound. If they strike an object, then they are reflected back as echo signals to the sensor, which itself computes the distance to the target based on the time-span between emitting the signal and receiving the echo. The ultrasonic sensor and water pump will be controlled by Arduino uno.

#### Twin rudder

The fluid force acting on the conventional rudder creates resistance, but the main feature of the Twin Rudder is that it uses the "duct effect" to convert the fluid force into thrust. Duct effect is a phenomenon in which a fluid enters a duct with a special cross-sectional shape that surrounds a propeller to create a velocity difference, and as the result, the forward component of the lifting power contributes to thrust.

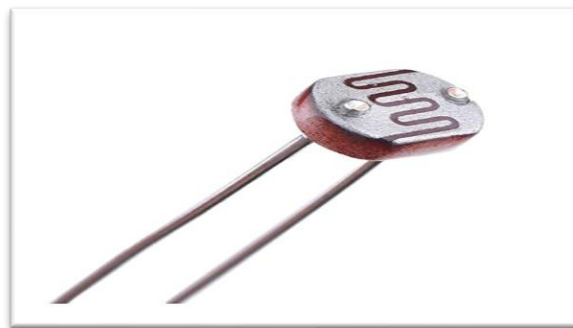


**Fig.6:** *Twin rudder system*

## Automatic navigation lights system

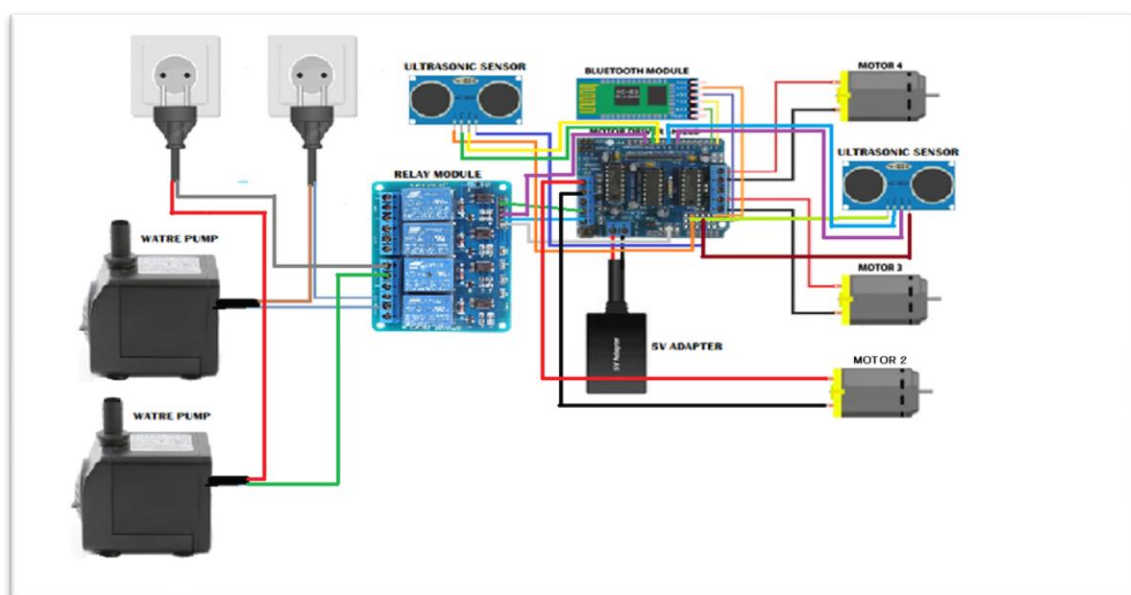
A light dependent resistor is also known as photo-resistor. It is a device whose resistivity is a function of the incident electromagnetic radiation or light. They are made up of semiconductors with high resistance. LDR works on the principal of photo conductivity, an optical phenomenon in which materials conductivity is reduced when light is absorbed by the material.

When light falls, that means when the photons Fall on device electrons in the valence band of the semiconductor material, are excited to the conduction band, these photons in the incident light should have energy greater than the band gap of the semiconductor material to make the electrons jump from the valence band to the conduction band. Hence, when light having enough energy strikes on the device more and more electrons are excited to the conduction band, which results in large number of charge carriers. The result of this process is more and more current starts flowing through the device. If the circuit is closed and hence. It is said that the resistance of the device has been decreased. This is nice Foreman working principle of ldr.

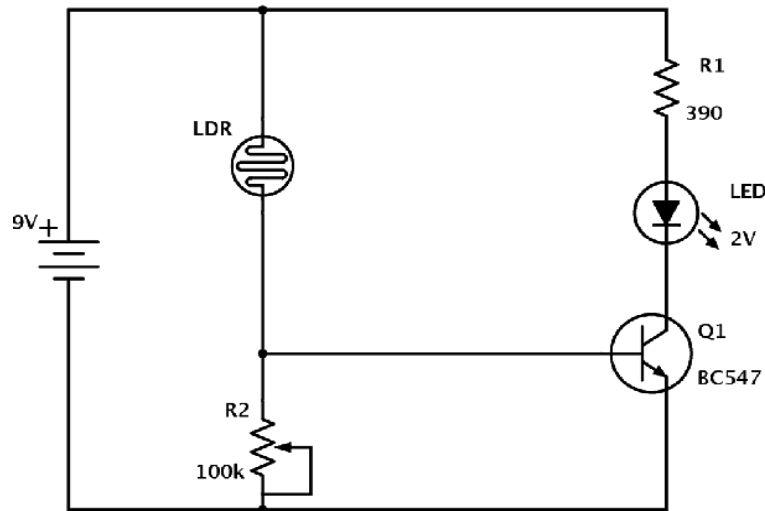


**Fig.7:** Light dependent register

## VII. DETAILED DIAGRAM



**Fig.8:** Circuit diagram of anti- piracy and mammal safety system



**Fig.9:** Circuit diagram of LDR

## VIII. CONCLUSION

As this is a demonstration model, it is made at very low cost. Practically, wide range ultrasonic sensors will be placed in freeboard of the ship for better detection of solid objects near ship. Heavy duty water cannon will be installed for high pressure sprinkling of water. The motor driven propeller is simply turned off when whale comes too near to the propeller, but practically a clutch system will be provided which will disengage the propeller from main engine crank shaft.

## IX. REFERENCES

1. <https://www.build-electronic-circuits.com/ldr-circuit-diagram/>
2. <https://www.kamomepropeller.co.jp/en/products/gaterudder/#:~:text=The%20Gate%20Rudder%C2%AE%20consists,on%20a%20completely%20new%20idea.>
3. [https://www.researchgate.net/figure/Result-of-ship-strike-to-large-whales\\_fig4\\_266408749](https://www.researchgate.net/figure/Result-of-ship-strike-to-large-whales_fig4_266408749)
4. <http://marinemammal.uga.edu/index.php?page=information/threats>

# IDEAL MODEL SHIPS (IMS)

Abhishek Kumar<sup>a</sup>  
Tolani Maritime Institute  
abhishek.kumar2020me@gmail.com

Aditya Singh<sup>b</sup>  
Tolani Maritime Institute  
aditya.singh2020me@gmail.com

Aditya Balaji Sharma<sup>c</sup>  
Tolani Maritime Institute  
aditya.sharma2020me@gmail.com

Ansh Singh Rajpal<sup>d</sup>  
Tolani Maritime Institute  
ansh.rajpal2020me@gmail.com

## I. ABSTRACT:

Blue Economy is the sustainable use of ocean resources for economic growth, improved livelihoods, and job while preserving the health of ocean ecosystem. Since the 1970s the world has begun to be acutely aware of the impact of climate change and the influence fossil fuels has had on the progress of the natural migrations of climate. It is with that in mind that the United States Department of Defense is seeking to change the profile of its energy usage. The United States Navy's Great Green Fleet was an energy cost saving measure announced in 2018 to begin using a combination stern flaps Balast Water Treatment, modification of the bulbous bow to reduce drag and other fuel saving, pollution reducing techniques. The first demonstration by the USS Nimitz carrier task group during RIMPAC (Rim of the Pacific exercise) in 2020 was completed without incident. The Great Green Fleet, the popular nickname, is an homage to the Great White Fleet of the early 20th century. In this model we have applied the principles set by this case study to create an ideal model ship as a beacon of hope for the future, that if we continue to push the boundries of research related to blue economy and clean shipping such a ship could soon be the optimal standard for all ships sailing on our oceans

## II. OBJECTIVE:

The main objective of this model is to use the principles set by the Great Green Fleet Project to create an ideal model ship. Stern flaps are installed which are used to modify the way the water flows under the hull afterbody resulting in reduced drag and fuel consumption. A Retrofitted bulbous bow {nose job} to improve fuel efficiency and ballast water treatment to provide stability and maneuverability during the voyage when the ship is not carrying any load

## III. INTRODUCTION:

Ideal model ships [IMS] is a blueprint for the future generations as we intend to combine multiple ecological, cost efficient and sustainable operations/methods, tested and used earlier into a single ship to promote the idea of blue economy.

#### **IV. CONCEPT:**

We have implemented multiple technologies each having its own unique concept and working all of which work in perfect harmony towards a singular goal of creating a cleaner and greener environment for our future generations

##### **Bulbous Bow**

It is reported that large ships with conventional clipper bows can have 12-15% more fuel efficiency when coupled with a bulbous bow. Moreover, seakeeping characteristics have also improved inclusion of bulbous bow in the design (reduction in pitching, improved buoyancy of the fore part. However, there are certain conditions that determine whether a bulbous bow would improve the fuel efficiency.

When a ship sails, it generates waves by imparting energy to the water particles around it. There are layers of fluid around the ship's body and certain parts of the ship are responsible for this 'system' of waves generated as a result of the abrupt curvature at the ship's stem, owing to the rise in pressure.

##### **Stern Flap**

The main purpose of a stern flap device is to reduce the shaft power required to propel a ship through the water, thereby reducing the engine's fuel consumption and increasing the ship's top speed and range. The application of stern flaps to large displacement vessels is a fairly recent innovation. The US Navy has been investigating the use of stern flaps on many different hull types. Stern flaps have now been proven by the US Navy to reduce the requisite amount of propulsive power during navigation, with several concomitant advantages. Stern flaps: foster reductions in operating and life-cycle costs through fuel savings; increase both ship speed and range; decrease the amount of pollutants released by ships into the atmosphere.

##### **Balast Water Treatment**

Invasive Aquatic Species in ship's ballast water is one of the biggest problems faced by the shipping industry. Posing a great threat to the marine ecosystem, these aquatic species has led to an increase in bio-invasion at an alarming rate the implementation of a ballast water management plan and ballast water treatment system on board ships has thus become important.

#### **V. Working Principle:**

##### **Bulbous Bow**

When a ship sails, it generates waves by imparting energy to the water particles around it. There are layers of fluid around the ship's body and certain parts of the ship are responsible for this 'system' of waves generated as a result of the abrupt curvature at the ship's stem, owing to the rise in pressure. This is because the ship is not stationary and the motion across the viscous fluid layers creates differences in pressure at various points – some regions of positive pressure and some negative, ultimately giving rise to two wave systems, broadly, the transverse and the divergent wave systems.

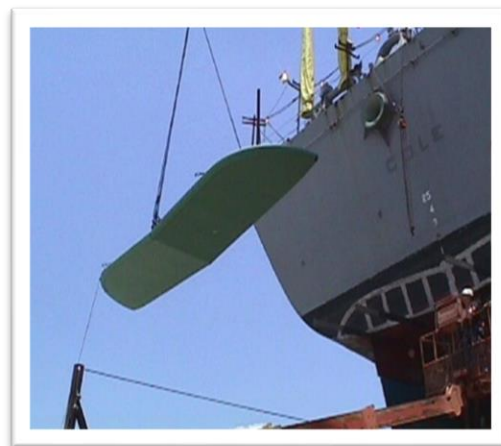
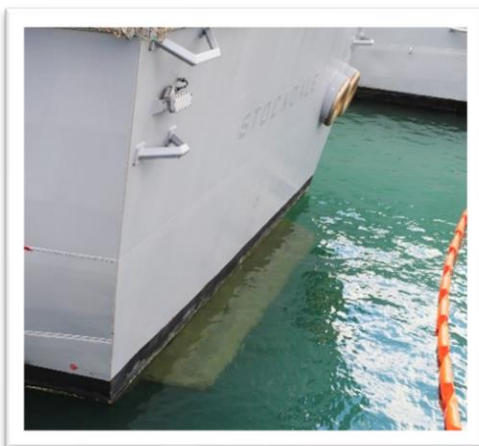
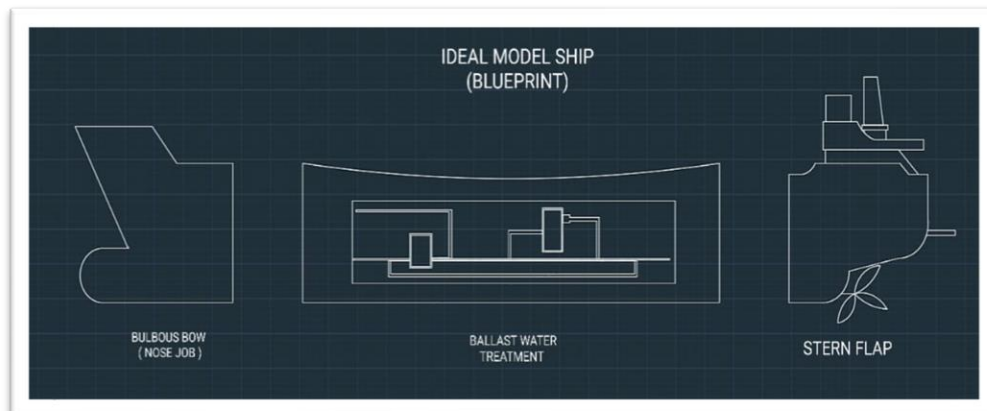
### Stern Flap

Stern flaps create a vertical lift force at the transom modifying the pressure distribution on the aft portion of the hull. This reduces the drag on the ship, which modifies the wave resistance of the ship, therefore reducing the propulsion power required to achieve a given speed. This, in turn, reduces fuel consumption and provides commensurate cost savings and environmental benefits.

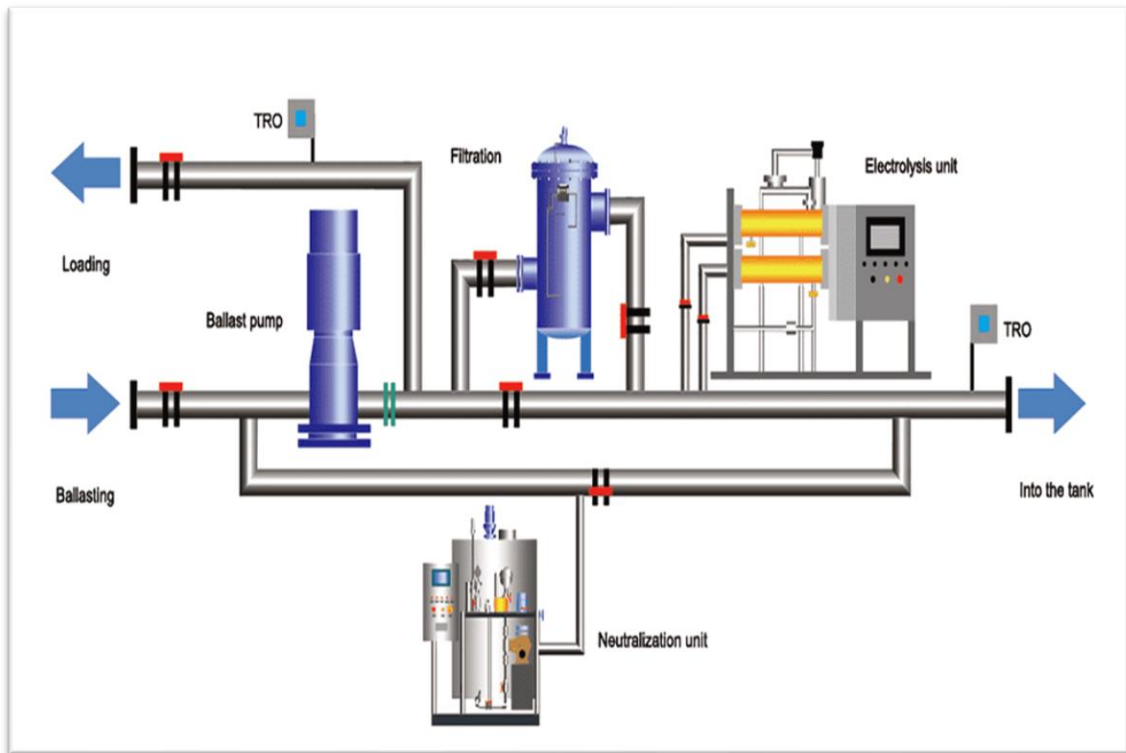
### Ballast Water Treatment

Physical separation or filtrations systems are used to separate marine organisms and suspended solid materials from the ballast water using sedimentation or surface filtration systems. The suspended/filtered solids and waste (backwashing) water from the filtration process is either discharged in the area from where the ballast is taken or further treated onboard ships before discharging. The ultraviolet ballast water treatment method consists of UV lamps that surround a chamber through which the ballast water is allowed to pass. Biocides (Oxidizing and non-oxidizing) are disinfectants that have been tested to potentially remove invasive organisms from ballast water

### VI. DETAILED DIAGRAM:



**Fig1:** Stern Flap

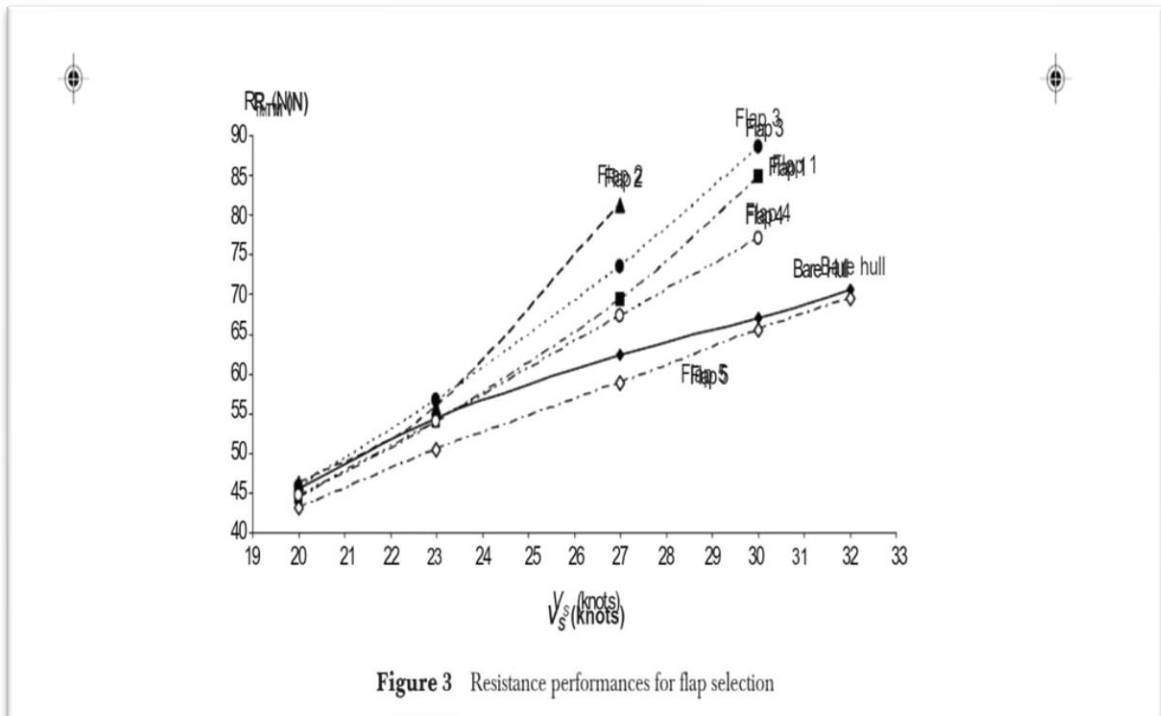
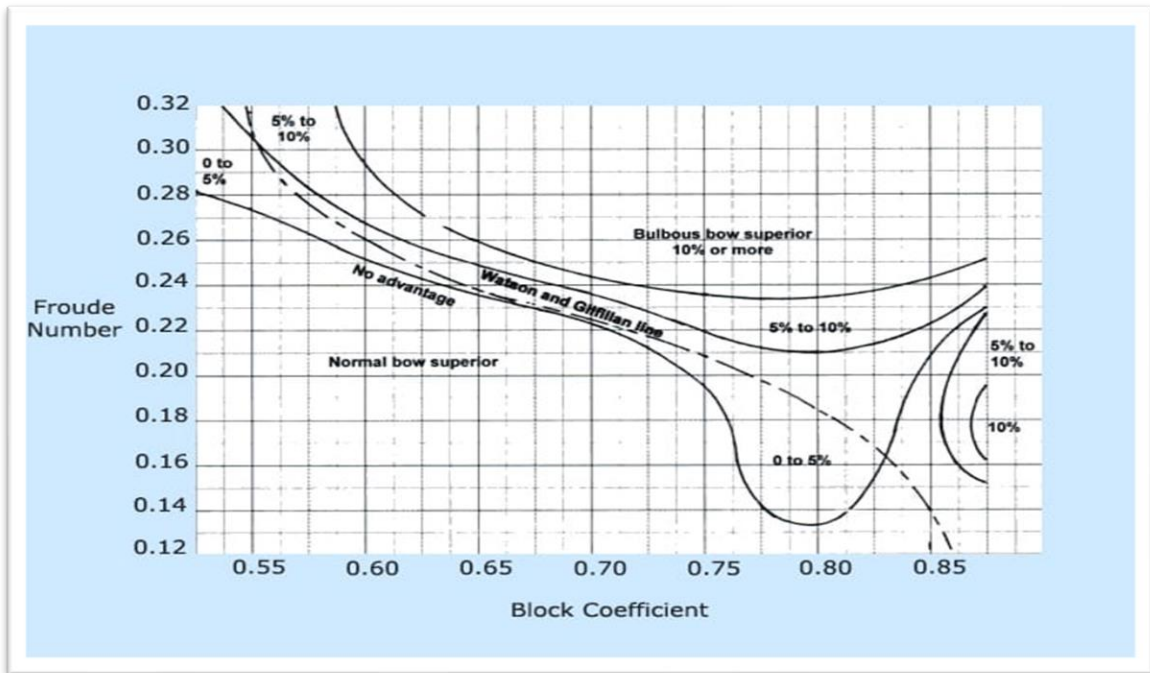


**Fig2:** *Ballast Water*

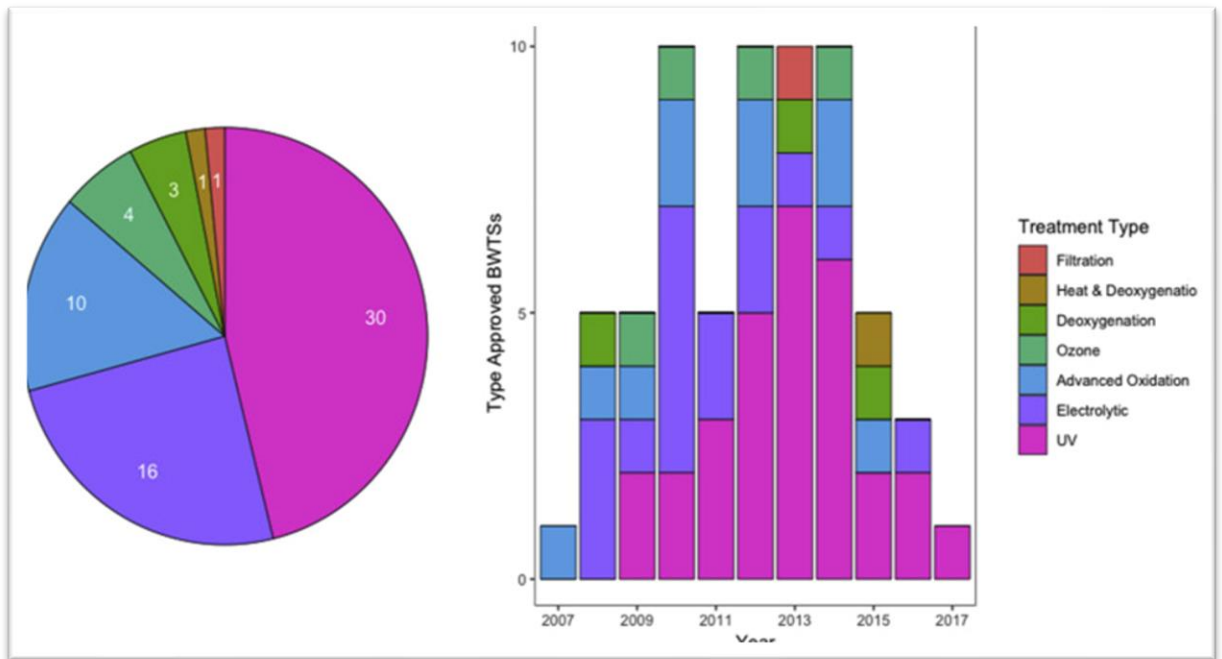


**Fig3:** *Bulbous Bow Modification*

**VII. RESULTS (TABLES/GRAPHS) :**



**Figure 3** Resistance performances for flap selection



### VIII. CONCLUSION:

We observed that 'Nose job' for ships as the replacement of the bulbs ensures better performance in slow steaming environments. A new bulbous bow could provide better fuel savings, while they could also contribute to CO2 emissions reduction.

Also stern flaps reduce flow velocity and increase dynamic hull pressure. Increased pressure area causes greater lift force which produces a positive effect on boat movement and stern flaps also increase the trailing edge outflow speed as compared to the transom area without flaps.

### IX. REFERENCES:

1. <https://www.marineinsight.com/maritime-law/everything-you-wanted-to-know-about-ballast-water-exchange-and-management-plan/>
2. Report on Statistics of Indian shipbuilding and ship repairing industry 2010-2011, Government of India, Ministry of shipping, Road Transport and Highways, February 2012.
3. <https://www.marineinsight.com/naval-architecture/different-types-ships-sterns/>
4. <https://www.marineinsight.com/naval-architecture/why-do-ships-have-bulbous-bow/>

# GREEN ENERGY POWER GENERATION ON SHIP USING VAWT

Aryadeep Bharadwaj<sup>a</sup>  
Tolani Maritime Institute  
a.bharadwaj2020ME@gmail.com

Arpit Raj<sup>b</sup>  
Tolani Maritime Institute  
arpit.raj2020me@gmail.com

Harshvardhan Bhati<sup>c</sup>  
Tolani Maritime Institute  
harshvardhan.bhati2020me@gmail.com

## I. ABSTRACT:

Vertical Axis Wind Turbines (VAWTs) represent a unique form of power-generating technology. With increased concern for environment now days led to the research for more eco-friendly sources of energy and with this considerations wind energy can be deliberated as a feasible option in this regard Wind energy is one of the non-conventional forms of energy and it is available in affluence in sea. Electricity can be generated with the help of vertical axis wind turbine. This projects aims of utilizing this wind energy in most effective manner to get the maximum electric output, and therefore we can use our ships as our installation site. In this project a small model has been created for testing purpose. This project also aims for maximum output with minimum cost indulge. Vertical Axis Wind Turbine (VAWT) is relatively simple to implement on ships the development of appropriate design of VAWT will open new opportunities for the large-scale acceptance of these machines.

## II. OBJECTIVE:

Vertical axis wind turbines (VAWT) are capable of producing a lot of power, and offer many advantages over (HAWT). The main objective of this project is to design and build a self-starting vertical axis wind turbine to operate in low/high wind speed condition in seas on ships.

**III. KEYWORDS:** Vertical Axis Wind Turbines (VAWTs), Green energy, Blue Economy.

## IV. INTRODUCTION:

It is well known that to run various machineries aboard a vessel we require electricity which is being generated through the installed generators which run on Marine diesel oil and add to the ever-increasing list of deterrents that add to pollution and carbon emission every day. New researches are being undertaken to reduce pollution through ships controlling and monitoring agencies like MARPOL which have laid down regulations and goals along these parameters. Wind is the secondary form of solar energy and is always being replenished by solar energy. Wind energy is associated with the kinetic energy of flowing wind. For our model, the optimum conditions for working of VAWTs were determined. The details of these methods and principles along with the major findings of the researchers on the vertical axis Wind turbines are reviewed in this paper. Upon a closer look at the concepts the fact that VAWTs are suitable for power loads where the conditions are not favorable over the traditional HAWTs Such as in high wind velocity and turbulence due to fluctuation in the wind. Another major advantage is that VAWTs are Omni-directional thus is able to harness wind from any direction, without any

expected mechanism yawing. And a comparison between VAWTs vs. HAWTs is made in *Table 1*. This table makes it clear that a number of promising features which, if properly exploited can be a better option over traditional solutions. Wind energy is freely available in the atmosphere as non-renewable energy source. To utilize wind energy to generate electricity and to store the same electrical energy by using wind turbine. Basically, there are two types of wind turbines available and research and development of study and analyzing is in process namely horizontal and vertical axis wind turbine. Since a long era, the horizontal wind turbine was popular as a renewable energy development medium. With research, study and development, the vertical axis wind turbine also developed and the latest trend of art of technology is becoming popular in experimentation and installation of same vertical axis wind turbine due to compactness and being lighter in weight the vertical axis wind turbines can be easily installed in all types of ships.

#### **V. CONCEPT:**

Vertical axis wind turbines are wind turbines whose rotors rotate around a vertical shaft the main rotor shaft is set transverse to the wind (but not necessarily vertically) while the main components are located at the base of the turbine. With vertically oriented blades, they produce electricity by utilizing wind power the same way horizontal axis wind turbines do: Wind drives the rotor to turn, the rotation connects to the generator, and the generator converts the mechanical energy into electricity. Vertical axis wind turbines, on the other hand, are more geographically flexible and not restricted as much by governmental policies due to its versatile and compact nature compared to its horizontal counterpart.

#### **VI. WORKING PRINCIPLE:**

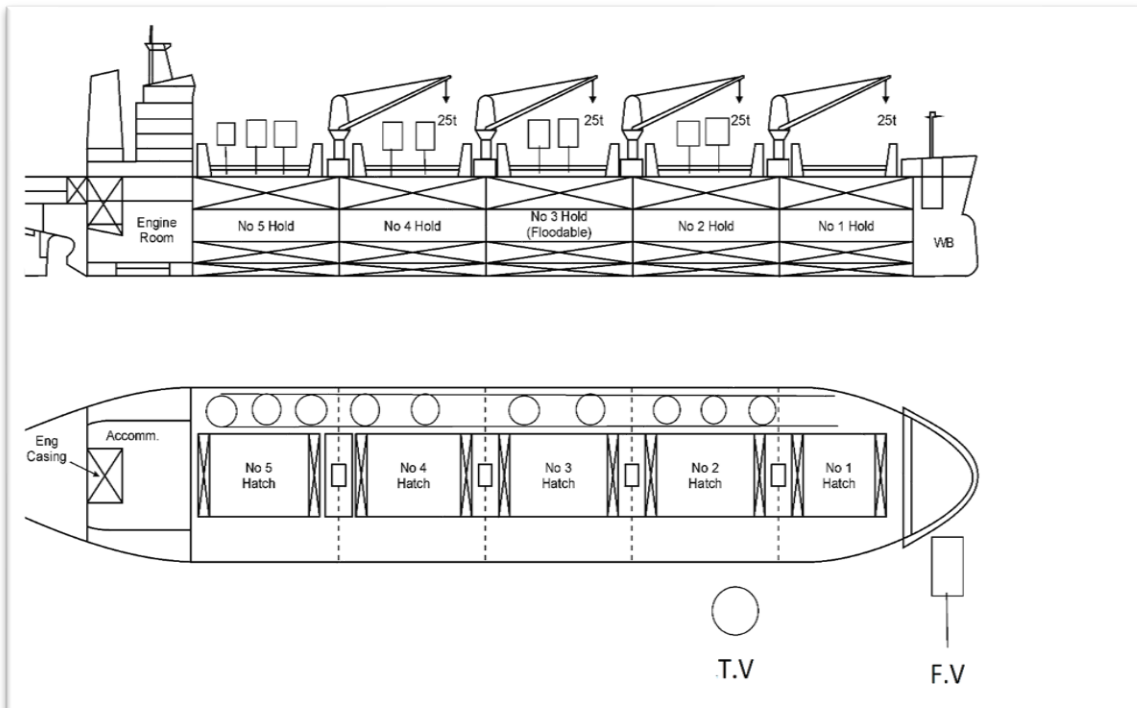
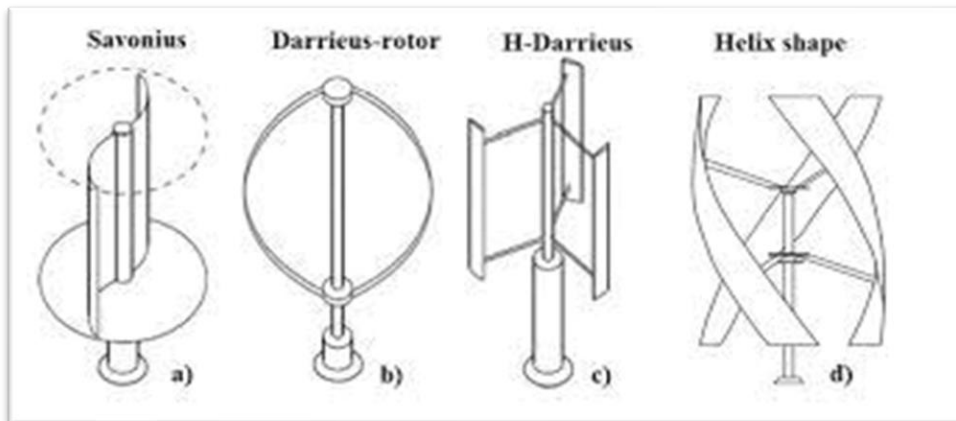
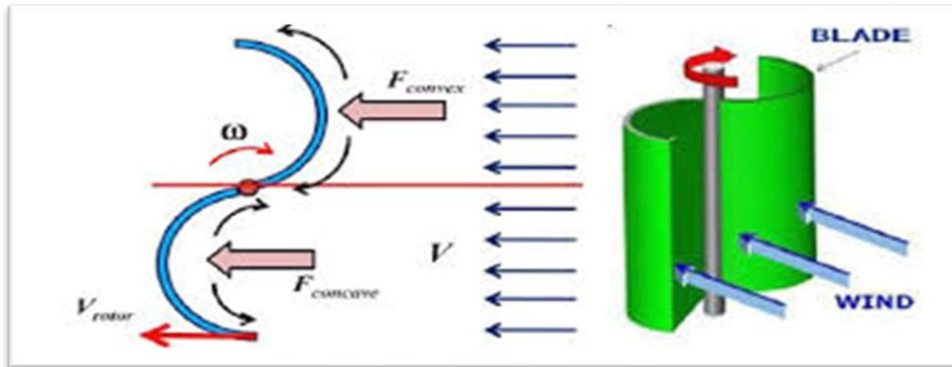
This turbine works once the wind turns the turbine. Here, the savonius VAWT is used in this system. Once this turbine rotates, then the generator will get it as mechanical input and generate the output as electrical energy. The shape of turbine wings is curved to get the wind for revolution from the sea breeze where wind speed will make this turbine rotate. Here, wind speed is used in different ways based on our requirements.

A vertical axis wind turbine is connected to the Gearbox which includes gears. This gearbox is directly connected to the electric generator shaft. This turbine will revolve once the wind blows & the gearbox in this system will enhance the turbine rotations internally & send these rotations to the generator like a mechanical input. So the generator will generate the output as the electrical energy by using this input so that this output will be stored within the rechargeable battery.

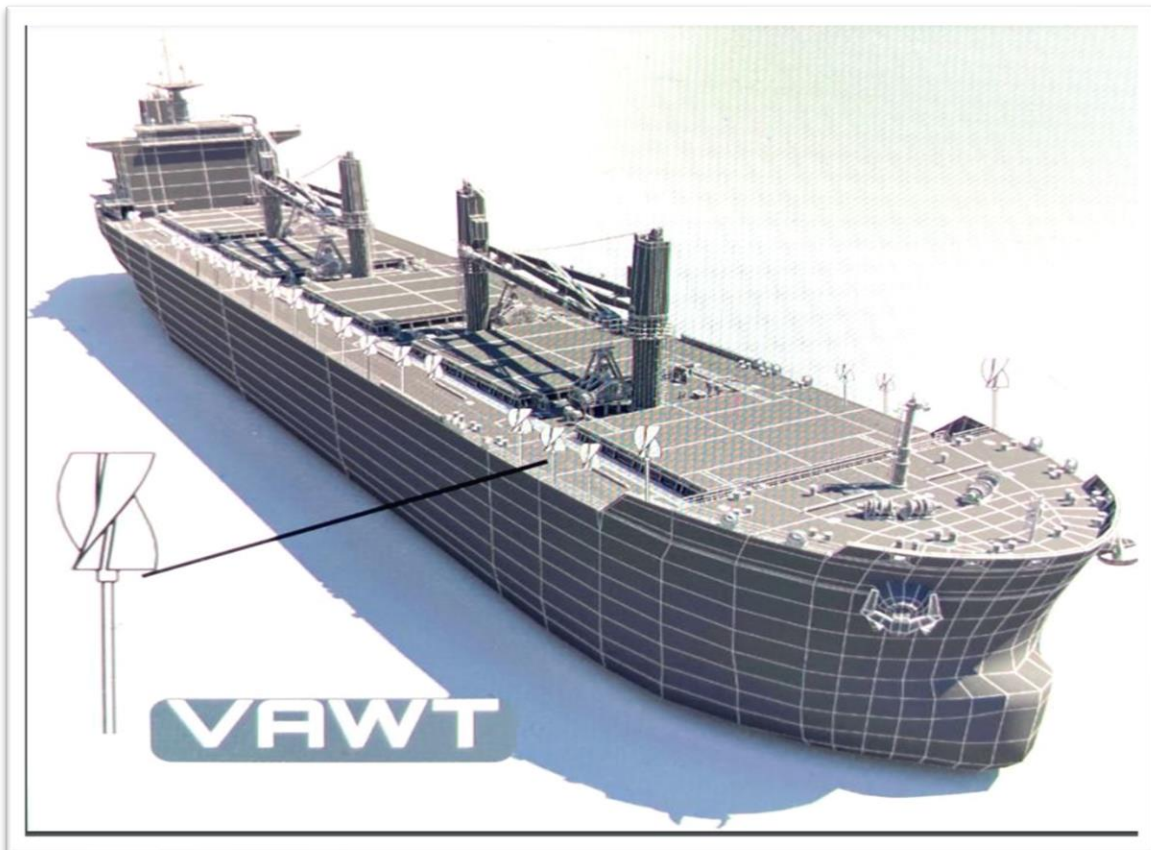
In this way, electricity is generated and stored in the battery.

As the name implies, the rotation axis of this type of wind turbine is perpendicular to the ground and also perpendicular to the direction of the wind, because most of the wind blows along the ground. Vertical axis wind turbines do not need a yaw mechanism to face the wind direction, because wind from all directions can drive the wind turbine to rotate, which is one of the major features. Vertical axis wind turbines can be divided into drag-type and lift-type according to the principle of operation.

VII. DIAGRAM:



## VIII. 3D



## IX. RESULTS:

**Table 1. Merits of vertical axis wind turbines over horizontal axis wind turbines**

|                          | Horizontal axis wind turbine (HAWT) | Vertical axis wind turbine (VAWT) |
|--------------------------|-------------------------------------|-----------------------------------|
| Tower sway               | Large                               | Small                             |
| Yaw mechanism            | Yes                                 | No                                |
| Self-starting            | Yes                                 | No                                |
| Overall Set-up Formation | Complex                             | Simple                            |
| Generator location       | Not on ground                       | On ground                         |
| Height from ground       | Large                               | Small                             |
| Blade's operation space  | Large                               | Small                             |
| Noise produced           | high                                | Relatively Less                   |
| Wind direction           | Dependent                           | Independent                       |
| Obstruction for birds    | High                                | Less                              |
| Ideal efficiency         | 50–60%                              | More than 70%                     |

In 2008, in a particularly high-profile example, the manufacturer PacWind integrated 16 of its drum VAWTs into a Times Square billboard. The project was supposed to save as much as \$12000 to \$15 000 per month in electricity costs and prevent 16.3 metric tons of carbon from being released into the air yearly (Collins, 2008).

## X. RESULTS AND DISCUSSION

The average natural wind speed to be 6 m/s. Density of air is 1.204 Kg/m<sup>3</sup>. Turbine 1.2 m in diameter and 1.0m height, the power of the Wind is given by,

$$P_w = \frac{1}{2} \rho A u^3$$

Where,

$P_w$  - power of the wind (W)

$\rho$  - Air density (kg/m<sup>3</sup>)

A - Area of a segment of the wind being considered

U - Undisturbed wind speed (m/s)

$$A = D l_b$$

Where,

A- Swept area (m<sup>2</sup>)

D-diameter of the turbine (m)

$l_b$ - length of the turbine Blades (m)

$$A = (1.2) * (1.0) = 1.2 \text{m}^2$$

$$P_w = \frac{1}{2} * (1.204) * (1.2) * (6)^3$$

$$= 156.03 \text{ watt}$$

**Table 2.2. Comparison between Theoretical and Experimental mechanical power**

| Wind Velocity<br>(m/s) | mechanical power (W)<br>(Theoretical) | mechanical power (W)<br>(Experimental) |
|------------------------|---------------------------------------|--|
| 4.5m/s                 | 65.8watt                              | 48.8 watt                              |
| 5.5m/s                 | 120.18watt                            | 102.3 watt                             |
| 7.5m/s                 | 304.76watt                            | 260.68 watt                            |
| 10m/s                  | 722.40watt                            | 610.74 watt                            |

## **XI. CONCLUSION:**

As this is a proposed model, it is built at very low cost. Instead of plastic, if Fiber Reinforce Plastic (FRP) is used it will yield to more output. 2) The Word hybrid means a thing which is made by the combination of more than one element. In energy system, electricity can be produced by more than one source at a time like Wind, solar, biomass etc. There are various methods to generate hybrid energy like wind-solar, Solar- diesel, Wind- hydro and Wind – diesel. Among the above listed hybrid energy generation module the wind- Solar hybrid module are more crucial because it is available abundant in nature and it is also very much environment friendly Although the efficiency of a VAWT is generally lower than that of a HAWT, it is actually very close in theory. And vertical axis wind turbines can accept wind in any direction, so there is no need for a yaw mechanism, and the generator can be installed under the main shaft. The low centre of gravity also makes the structure simple, and It also has the characteristics of being able to operate in unstable air flows, so it is suitable for installation in environments with complex spaces, such as mountains, urban buildings, etc. Therefore, although vertical axis wind turbines have not yet been successful on a large scale Commercial operation, but still have the potential for application on ships. Therefore we can create a wind harness power plant on ships to reduce usage of MDO and can be also help in reducing carbon emission. In 3.5 years a VAWT can recover its installation cost and average self-life of a VAWT is around 20 years so it is also economically feasible.

## **XII. REFERENCES:**

1. [https://www.researchgate.net/publication/308748091\\_Vertical\\_Axis\\_Wind\\_Turbine\\_or\\_Highway\\_Application](https://www.researchgate.net/publication/308748091_Vertical_Axis_Wind_Turbine_or_Highway_Application)
2. <https://www.sciencedirect.com/topics/engineering/vertical-axis-wind-turbine>
3. [http://ijaerd.com/papers/finished\\_papers/A%20Review%20Paper%20on%20Vertical%20Axis%20Wind%20Turbine%20for%20Design%20and%20Performance%20Study%20to%20Generate%20Electricity%20on%20Highway-IJAERDV03I1231667.pdf](http://ijaerd.com/papers/finished_papers/A%20Review%20Paper%20on%20Vertical%20Axis%20Wind%20Turbine%20for%20Design%20and%20Performance%20Study%20to%20Generate%20Electricity%20on%20Highway-IJAERDV03I1231667.pdf)
4. <https://www.journalijdr.com/sites/default/files/issue-pdf/1667.pdf>

# THERMOELECTRIC COOLER- WASTE HEAT RECOVERY SYSTEM ON SHIPS

Shardul Shantanu Bendre<sup>a</sup>  
Tolani Maritime Institute  
shardul.bendre2020me@gmail.com

Shaurya Sharma<sup>b</sup>  
Tolani Maritime Institute  
shaurya.sharma2020me@gmail.com

Vipul Kumar Dubey<sup>c</sup>  
Tolani Maritime Institute  
vipulkumar.dubey2020me@gmail.com

Deepak Sanjay Shinde<sup>d</sup>  
Tolani Maritime Institute  
deepak.shinde2020me@gmail.com

## I. ABSTRACT:

We know that 'maritime shipping' has a huge impact on the world economy and almost 90% of international trade is carried by merchant ships. The maritime field is now adopting various methods as per the need of time. This project aims of generating free electricity by converting waste heat energy from exhaust.

Ship industry produces a large amount of waste heat, which is to some extent used as thermal and rarely as electrical energy. Ships normally generate a lot of waste heat of a quantity as well as quality to cover all the needs for thermal energy onboard.

## OBJECTIVE:

To utilize waste heat energy produced onboard ship to electrical energy which can be used for performing various activities.

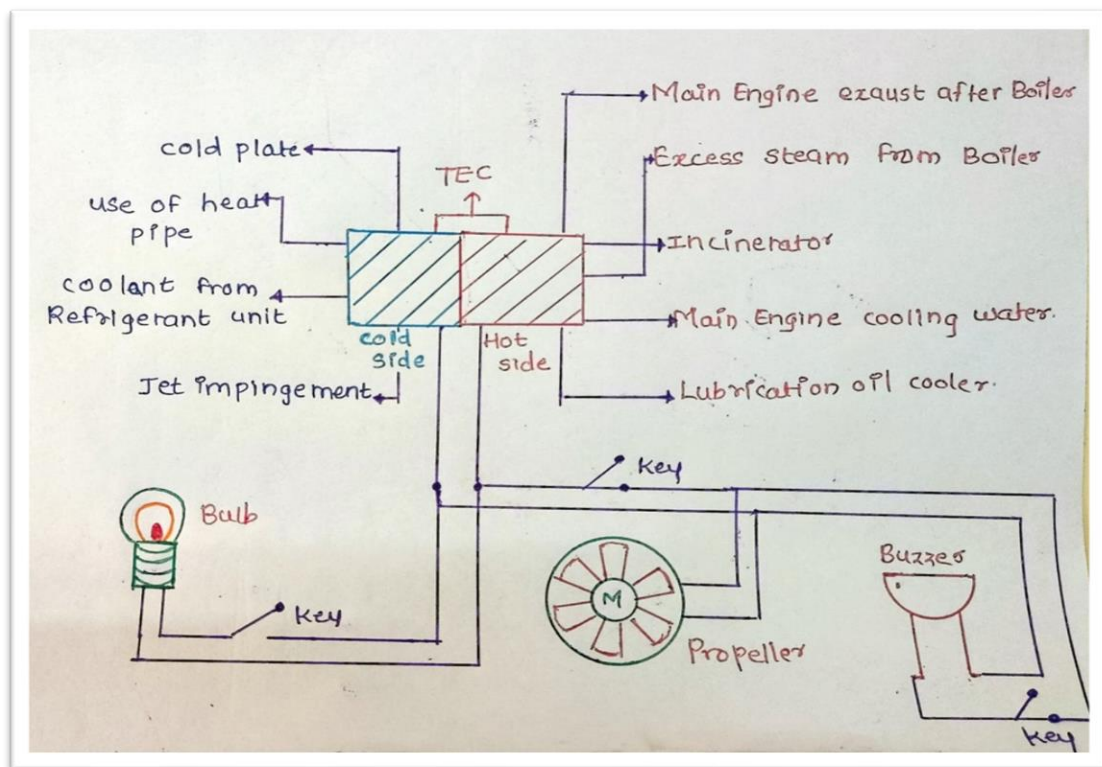
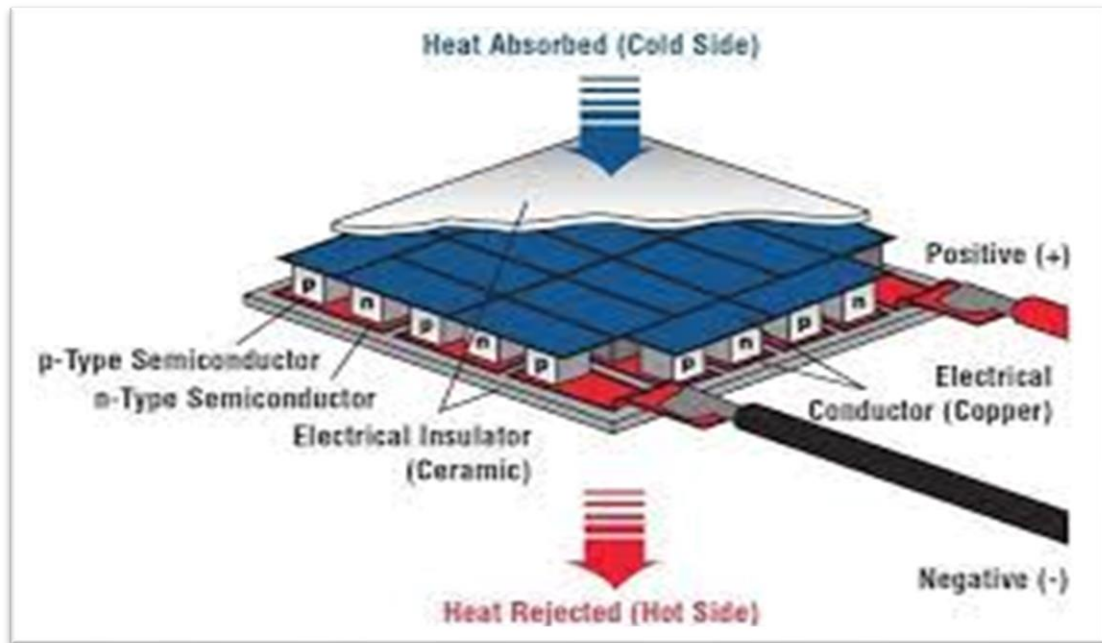
## II. INTRODUCTION:

Energy savings motivated by economic and environmental reasons have brought attention to waste heat recovery technologies. Thermal energy is a by-product in every power generation, so we can utilize this energy in various applications. For any heat engine, the laws of thermodynamics place fundamental constraints on the amount of useful power which can be extracted and leads them to release large amounts of heat to the surrounding. Shipping processes often require high temperatures leading to large waste heat flows. As every human activity seems to produce waste heat, recovering this energy strikes as a valuable manner of saving resources and reduces the damage to the environment.

## III. WORKING PRINCIPLE:

Thermoelectric coolers (TEC) works on the principle of Peltier effect. Peltier effect creates a temperature difference between two electric junctions by transferring heat inside them. A voltage is applied across the conductors to create an electric current. When the current flows through the junction heat is removed at one junction and cooling occurs while heat is collected at the other junction. But here we are using the reverse effect which is known as Seebeck effect where we are generating electricity by cooling one surface of TEC and adding heat to the opposite surface.

#### IV. DETAILED DIAGRAM:



## V. RESULTS(TABLES/GRAPHS)

| Heat Source                      | Medium          | Temp. (°C) | Quantity                             | Estimated TEG Power (kW) |
|----------------------------------|-----------------|------------|--------------------------------------|--------------------------|
| Electrical generating unit       | Flue gas        | 340        | 0.69 Nm <sup>3</sup> /s <sup>a</sup> | 10.0                     |
| Incinerator                      | Flue gas        | 340        | 0.68 Nm <sup>3</sup> /s              | 9.7                      |
| Main engine exhaust after boiler | Flue gas        | 210        | 14.18 Nm <sup>3</sup> /s             | 42.4                     |
| Main engine scavenge air cooling | Air             | 162        | 13.92 Nm <sup>3</sup> /s             | 46.4                     |
| Excess steam from boiler         | Sat. steam      | 159        | 0.087 kg/s <sup>a</sup>              | 5.9                      |
| Main engine cooling water        | Fresh water     | 83         | 18 kg/s                              | 11.8                     |
| FW generator unit, boiling water | Fresh water     | 61         | 8.3 kg/s <sup>a</sup>                | 4.3                      |
| Lubrication oil cooler           | Lubrication oil | 49         | 46 kg/s                              | 2.1                      |
| FW generator unit, condenser     | Salt water      | 37         | 25 kg/s <sup>a</sup>                 | 0.4                      |

## VI. CONCLUSION:

Although the main engine produces the vast majority of waste heat onboard ships, the quality of the heat is low, as some of the heat has already been utilized. In order to take advantage of the main benefits of TEC such as modularity and flexible structure, it is reasonable to focus on smaller heat streams with higher temperatures that have not been utilized already. The flue gas from the auxiliary engines is also interesting, but normally only one out of three is running during sea voyages and all generator sets have separate flue gas stacks. A TEC installation in the waste oil incinerator has potential to utilize the high temperature in the combustion chamber and seems to be the best candidate for further study.

## VIII. REFERENCES:

1. <https://en.wikipedia.org>
2. <https://www.google.com/>
3. <https://www.slideshare.net/>
4. <https://www.marineinsight.com/>

# **AZIPOD PROPULSION WITH AIR LUBRICATION SYSTEM**

Cdt. Anil Kumar Padihar<sup>a</sup>  
Tolani Maritime Institute, Pune  
anil.padihar2019me@gmail.com

Cdt. Ayush Yadav<sup>b</sup>  
Tolani Maritime Institute, Pune  
ayush.yadav2019me@gmail.com

Cdt. Gagan Shreyas<sup>c</sup>  
Tolani Maritime Institute, Pune  
shreygagan123@gmail.com

Cdt. Arnab Dutta<sup>d</sup>  
Tolani Maritime Institute, Pune  
arnab.dutta2019me@gmail.com

## **I. ABSTRACT:**

Amid de-carbonization (2021) there have been many discussions regarding the alternative propulsion system in which AZIPOD propulsion system with electrically driven ships remains the all-time undefeated competitor. Cruise industry and shore-based vessel have been using this technology since long, which not only increases maneuverability but also provides more space in addition to many advantages over conventional rudder-propeller system. We can also reduce the amount of carbon emission by reducing the amount of fuel consumed by the ship. Air Lubrication system is one of the most effective ways of doing so by reducing the friction between the ship and water by creating a blanket of air bubbles between them. It does not require much modification of the ship's hull hence is easy to install.

In our model ship 'PRABHUVIDYA LNG' we have tried to show the working AZIPOD PROPULSION SYSTEM and AIR LUBRICATION SYSTEM explaining how efficient the same is. Some basic experiments conducted to prove efficacy of the system. However, some alterations are made due to limited resources. Although there are huddles to bring the technology to the actual operation on merchant vessel including power availability and training of master and crew. Yet this technology has a potential to bring change in movement of vessels around the globe and achieving our goal of 2050.

## **II. OBJECTIVE:**

- To completely eliminate the heavy weighted and space consuming rudder-propeller system.
- To enhance the maneuverability of ships.

- To reduce the resistance of the ship, in order to create energy saving effect.
- To contribute towards the zero- emission norms [electric propulsion].

### **III. INTRODUCTION:**

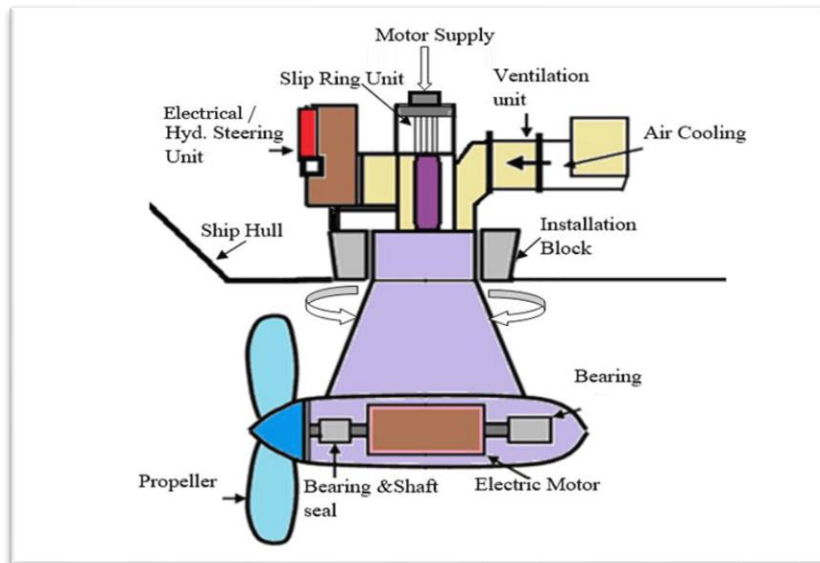
AZIPOD propulsion system is already existing technology in small yachts, Shore based vessel, cruise ships and tugboats. In which electric motor is located inside the hydrodynamic optimized housing. The entire unit is made to rotate 360 degree providing large turning force in any desired direction without the necessity of rudder. The system provides excellent maneuverability especially at lower speeds. Eliminate the shaft line, steering gear rudder, stern thruster thus, providing more cargo space, utilization of which can be more profitable to the Ship owners. Less vibration and noisy propulsion hence less maintenance. As compared to conventional rudder-propeller system, this system has many advantages, including the better turning ability, safe operation of ship without the assistance of ice breaker in the ice region.

Another concept we incorporated with AZIPOD propulsion system is Air lubrication to reduce frictional resistance offered to ship's hull, the reduction on the frictional resistance would result in an even higher reduction in power consumption in addition to what is achieved by the traditional optimization of the ship's hull form. Air lubrication technology can reduce this frictional drag for vessels, especially since this technology does not introduce major changes in hull form and the air injection rate can be adjusted. Air lubrication is achieved by pumping air beneath the hull, reducing the area of the hull in direct contact with the liquid flow. Although there are challenges too in adopting this technology which Includes training of master and crew, power limitation (14-25 MW), redesigning over stern part of ship, hence high capital cost. But with decarbonization (IMO 2021), ship-owners are switching to the alternative technology which could help them to achieve zero emissions. Since AZIPOD system entails power plant engine operating on diesel generator and producing electricity to propel the ship and air lubrication curtailing power requirement which has potential to reduce the emission considerably and preserving our mother earth.

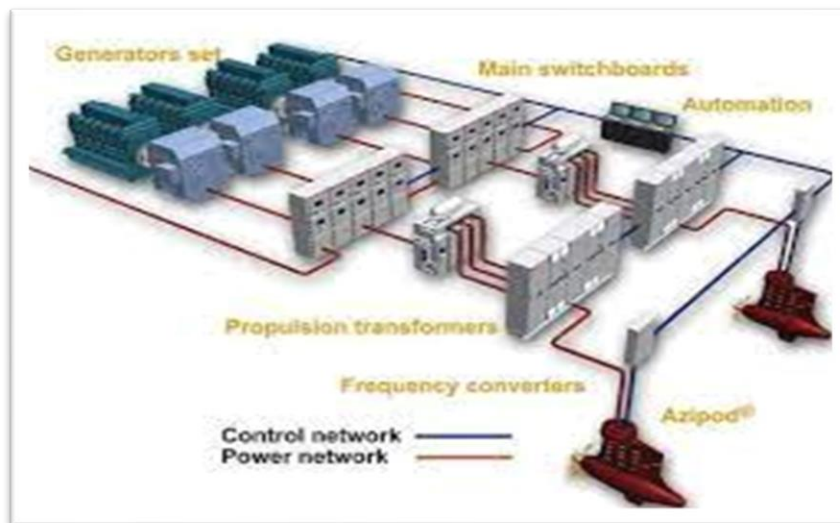
### **IV. CONCEPT:**

In the AZIPOD propulsion system, A huge variable frequency electric motor run by diesel generator is located inside a submerged pod which is mounted outside the ship's hull. The pod is coupled with the prime mover to another motor which can rotate the pod 360 degree in vertical axis. Or there may be independent steering gear system for rotating the pod.

Figure below best explains the concept of pod propeller.



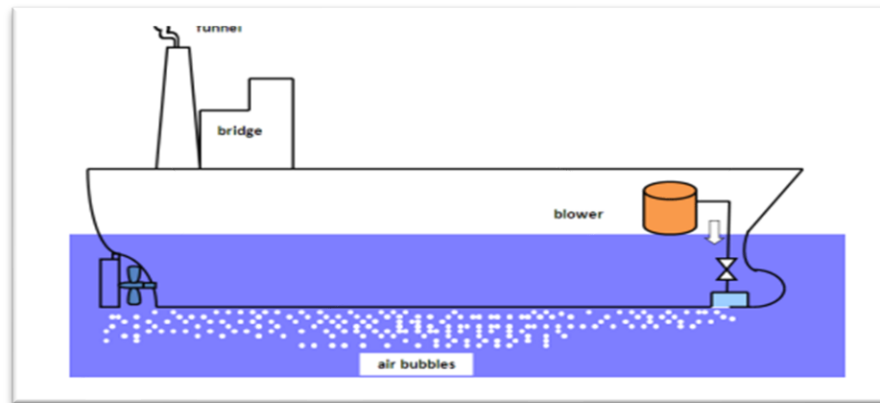
**Fig 1:** Pod Propeller Design



**Fig. 2:** Power Transmission to Azipod

Air Lubrication system is a method in which the air bubbles are injected between the ship's hull and seawater. The distribution of air bubbles reduces the contact surface area with seawater, thus reducing working resistance acting to the hull. In order to reduce fuel oil

consumption of the engine. The figure given is self-explanatory air lubrication system schematic.



**Fig. 3:** *Air Lubrication System Design*

## V. WORKING PRINCIPLE:

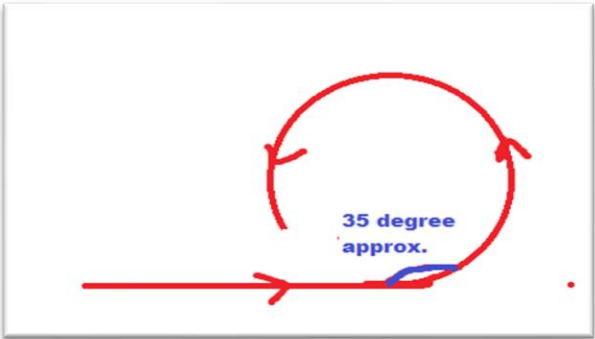
In the Construction of PVD LNG, we made use of the following equipments:

1. Geared motor 300rpm in propeller
2. 10 rpm D.C motor (steering)
3. 12V 2Amp battery
4. LED (red)
5. Resistance (10k)
6. Diode 4007
7. D.C socket
8. DPDT switch
9. 220V AC blower
10. Rubber Pipe
11. 4-way air jointer
12. Air reducer fitting
13. WPC board
14. PCB board
15. Copper wire

With the help of plywood (WPC) we made the structure of our model ship and the steering DC motor was mounted inside the hull of the ship as shown in detailed diagram. Pod is mounted on the shaft of the steering DC motor in which the propeller motor is mounted. The whole pod assembly is mounted below the hull fully submerged in water. Propeller motor is running the propeller which is moving the ship and the steering motor rotating the whole pod assembly 360 degree (vertical axis) making desirable motion of the ship. Plastic casing and bearing were used for proper sealing of the design as to prevent short circuiting of motors. Air lubrication was achieved simply by making holes in the hull of the ship and pipe connections were made and air blown through the pipes with the help of an air blower creating an air jacket beneath the hull surface of the ship.

After constructing our model ship PVD LNG we operated the ship practically which will be shown in our presentation video and it was observed that:

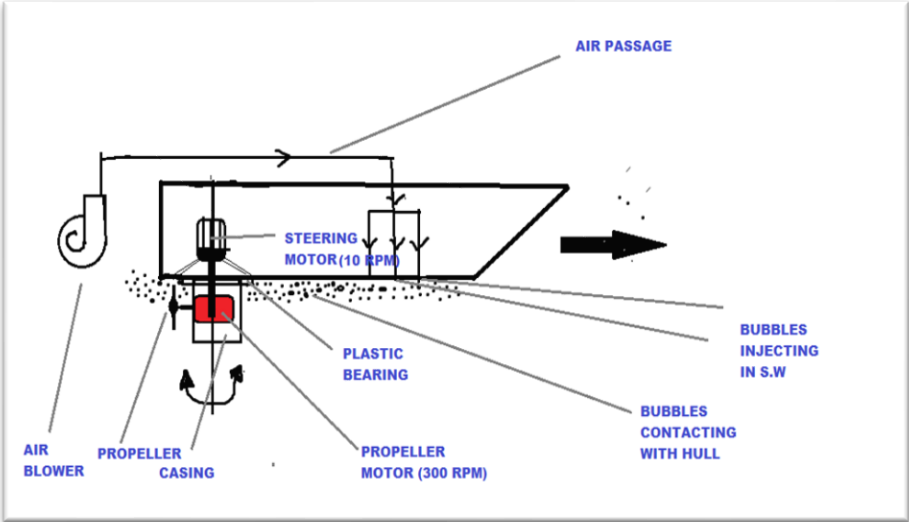
- The ship was able to take steep turns ensuring an efficient maneuverability.
- The ship was able to make a round circle with less pod angle (approx. 35 degree) as depicted below in figure.



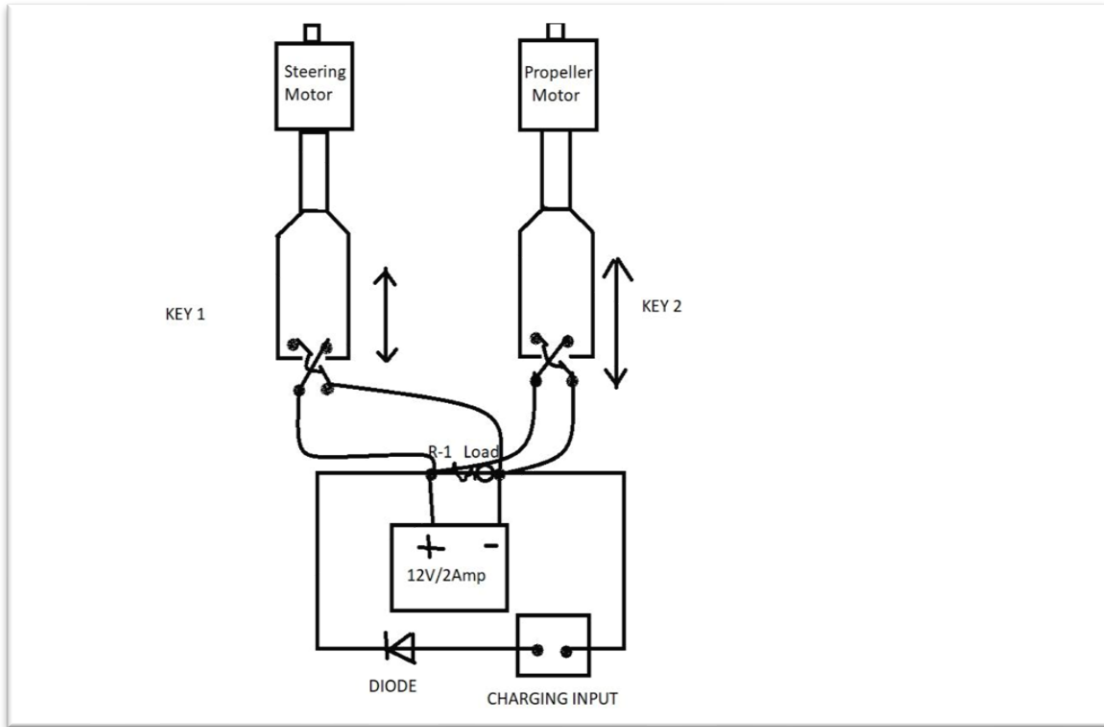
**Fig. 4:** Round Turn Of Pvd Lng

We also conducted a small experiment in which a certain distance A to B was covered by ship with or without use of the Air Lubrication system and time period was noted. And it was observed that the time taken was less when Air lubrication was incorporated. Thus, for the same velocity of ship load on the propeller motor will be less.

**VI. DETAILED DIAGRAM**



**FIGURE 4:** Detailed Schematic Diagram Of 'Pvd Lng '



**FIGURE 5:** *Circuit For Electrical Connections*



**FIGURE 6:** *Actual Model 'Pvd Lng' (Unfabricated)*

## **VII. CONCLUSION:**

Through our working model ship 'PVD LNG'. We tried our best to show the AZIPOD propulsion system with air lubrication technology. And it was quite evident that the AZIPOD propulsion with marine air lubrication can come out with advantageous results Including energy efficiency, less noise and vibrationless propulsion, High maneuverability, High space availability and providing far better design than conventional Rudder propeller system.

After conducting some basic experiments, it was ascertained that our model satisfied the purpose it was made for. However, there are some alterations with the actual concept proposed. But with the proper resources this idea can be taken to practicality. And we can see a new era of electric propulsion which is contributing towards the less GHG emissions, helping in compliance with the decarbonization (2021).

## **VIII. REFERENCES:**

- [1] <https://en.wikipedia.org/wiki/Azipod>
- [2] <https://www.marineinsight.com/green-shipping/how-air-lubrication-system-for-ships-work/>
- [3] <https://new.abb.com/marine/systems-and-solutions/azipod>
- [4] [https://www.wartsila.com/encyclopedia/term/azipod-\(azimuthing-podded-drive\)](https://www.wartsila.com/encyclopedia/term/azipod-(azimuthing-podded-drive))
- [5] IMO MEPC 73/19. (2018). Report of the marine environment protection committee on its seventy-third session.
- [6] IMO MEPC.1/Circ.815. (2013). 2013 guidance on treatment of innovative energy efficiency technologies for calculation and verification of the attained EEDI.
- [7] <https://instrumentationtools.com/speed-control-of-ship-electrical-motor-propulsion/>