

**Indian Maritime University**  
**June 2022 End Semester Examinations**  
**B. Tech (Marine Engineering)**  
**Re-examination**  
**Engineering Mechanics**  
**Semester II**  
**(UG11T4204)**

**Max Marks: 70**  
**Date: 26.06.2022**

**Pass Marks: 35**  
**Duration: 03 Hours**

**QUESTION PAPER**

**Part A**

<b>Q1 [10 x 1 = 10 Marks] Multiple Choice Questions</b>				
<b>Questions</b>	<b>Options</b>			
	<b>A</b>	<b>B</b>	<b>C</b>	<b>D</b>
(i) A framed structure is perfect, if the number of members are.....(2j -3), where j is the number of joints.	less than	equal to	greater than	None of these
(ii) A lifting machine having efficiency less than 50% is known as.....	Reversible machine	Non-reversible machine	Ideal machine	None of these
(iii) For an ideal machine, the mechanical advantage is equals to the .....	Velocity ratio	Tension ratio	Acceleration ratio	Load ratio
(iv) The centre of gravity is the ratio of .....to .....	The product of centroid and weight to the total weight	The addition of centroid and weight to the total weight	The subtraction of centroid and weight to the total weight	The product of centroid and weight to the total mass
(v) Theorem of perpendicular axis is used to obtained the moment of inertia of a.....	triangular section	square section	circular section	semicircular section
(vi) The distance travelled by the particle depends upon the.....of the particle.	path	size	dimensions	length
(vii) The horizontal range of a projectile is maximum when the angle of projectile is.....	30°	45°	60°	75°

(viii) ..... is the motion along a curved path.	plane motion	rectilinear motion	curvilinear Motion	None of these
(ix) .....the time taken by a particle for one complete oscillation.	Oscillation	Beat	Periodic motion	Amplitude
(x) A mass supported by a spring has a static deflection of 0.5 mm. The natural frequency of oscillation is.....	22.3 Hz	12.3 Hz	32.3 Hz	42.3 Hz

**Part – B**

**Q2 [2 x 5 = 10 Marks] - Short Answer Type Questions**

- (i) Define statics and Dynamics
- (ii) Define truss and a frame with a diagram.
- (iii) State the theorem of parallel axis
- (iv) Define instantaneous velocity and instantaneous acceleration
- (v) State any two laws of simple pendulum.

**Part – C**

**(Answer any Five out of Seven) Each Question is for 10 Marks**

**Q3.**

- a) A framed of 6 m span is carrying a central load of 10 kN as shown in Figure 1. Find the magnitude and nature of forces in all members of the structure by using method of joint and tabulate the results. (6 marks)

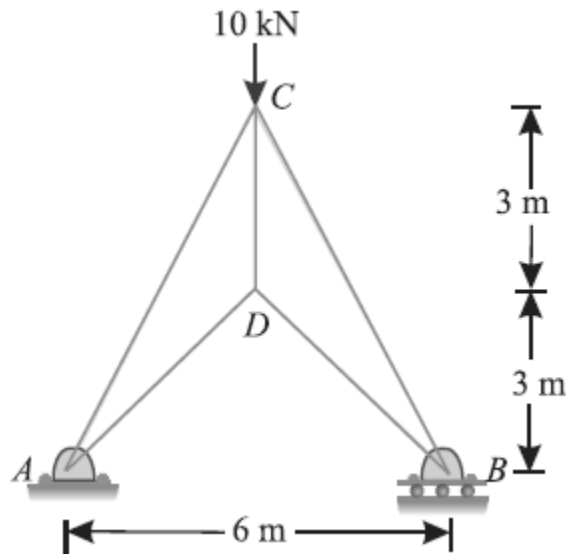
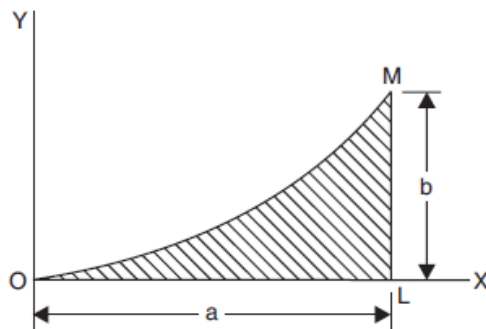

**Figure-1**

- b) Write down the assumptions made in the analysis of a simple truss (4 marks)

**Q4.**

- a) Determine the position of the center of gravity of the given shaded area of spandrel OLM shown in Figure 2, the curve OM being parabola with axis vertical. (6 marks)



**Figure-2**

- b) State Pappus Theorem-I and theorem-II. (4 marks)

**Q5.** Find the moment of inertia of a hollow section shown in Figure 3. about an axis passing through its centre of gravity or parallel X-X axis. (10m)

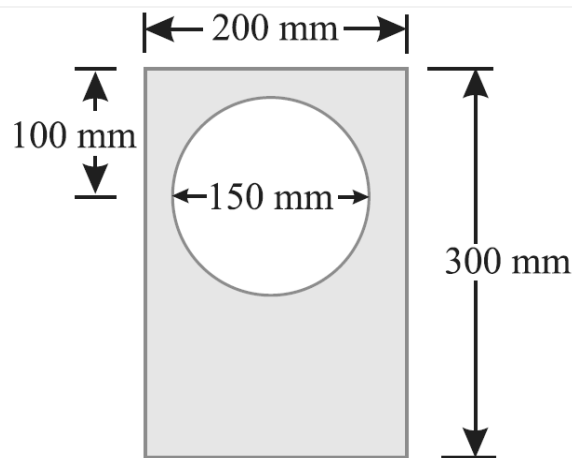

**Figure-3**

**Q6.**

- a) In a lifting machine, an effort of 40 N raised a load of 1 kN. If efficiency of the machine is 0.5, what is its velocity ratio ? If on this machine, an effort of 74 N raised a load of 2 kN, what is now the efficiency? (5m)
- b) Explain construction and working of simple wheel and axle. (5m)

**Q7.**

- a) The position of a particle moving on the x-axis is given by  $X=3.5t^3-7t^2$ , where 'x' is in meter and 't' is in seconds.
  - i) Determine the position at  $t=0,1,3,7$  seconds
  - ii) Determine the displacement during  $t=3s$  to  $7s$ .
  - iii) Find the average velocity during  $t=3s$  to  $t=7s$  and instantaneous velocity at  $t=3s$  ,  $7s$ . (5m)
- b) A body was thrown vertically downwards from the top of a tower and traverses a distance of 40 meters during its 4th second of its fall. Find the initial velocity of the body. (5m)

**Q8.**

- a) A body is projected at such an angle that the horizontal range is three times the greatest height. Find the angle of projection. (5m)
- b) The motion of a particle is defined by the relation  $x=t^2+5t$  and  $y=t^3-8t^2+2$  where 'x' and 'y' are expressed in meters and 't' is in seconds. Determine the velocity and acceleration at  $t=2$  seconds

**Q9.**

- a) A 4 kg mass hung at one end of a helical spring and is set vibrating vertically. The mass makes 2 vibrations per second. Determine the stiffness of the spring. (5m)
- b) A simple pendulum of amplitude  $4^\circ$  performs 24 oscillations in one minute. Find length of the pendulum and maximum acceleration of the bob. (5m)