

## LSA 46.2 / 47.1 ALTERNATORS Installation and maintenance

# LSA 46.2 / 47.1 ALTERNATORS

This manual concerns the alternator which you have just purchased.

The latest addition to a whole new generation of alternators, this range benefits from the experience of the world's leading manufacturer, using advanced technology and incorporating strict quality control.

## SAFETY MEASURES

Before using your machine for the first time, it is important to read the whole of this installation and maintenance manual.

All necessary operations and work on this machine must be performed by a qualified technician.

Our technical support service will be pleased to provide any additional information you may require.

The various operations described in this manual are accompanied by recommendations or symbols to alert the user to potential risks of accidents. It is vital that you understand and take notice of the following warning symbols.

### WARNING

Warning symbol for an operation which may damage or destroy the machine or surrounding equipment.



Warning symbol for general danger to personnel.



Warning symbol for electrical danger to personnel.

Note : LEROY-SOMER reserves the right to modify the characteristics of its products at any time in order to incorporate the latest technological developments. The information contained in this document may therefore be changed without notice.

We wish to draw your attention to the contents of this maintenance manual. By following certain important points during installation, use and servicing of your alternator, you can look forward to many years of trouble-free operation.

## WARNING SYMBOLS

A set of self-adhesive stickers depicting the various warning symbols is included with this maintenance manual. They should be positioned as shown in the drawing below once the machine has been fully installed.

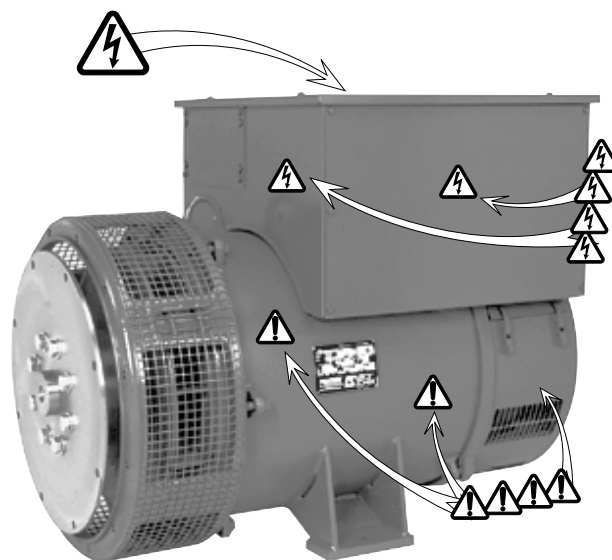

Copyright 2000 : MOTEURS LEROY-SOMER

This document is the property of :  
MOTEURS LEROY-SOMER

It may not be reproduced in any form without prior authorization.

All brands and models have been registered and patents applied for.

# LSA 46.2 / 47.1 ALTERNATORS

## CONTENTS

<p><b>1 - RECEIPT ..... 4</b></p> <ul style="list-style-type: none"> <li>Standards and safety measures</li> <li>Inspection</li> <li>Identification</li> <li>Storage</li> </ul> <p><b>2 - TECHNICAL CHARACTERISTICS ..... 5</b></p> <ul style="list-style-type: none"> <li>Electrical characteristics                             <ul style="list-style-type: none"> <li>Options</li> </ul> </li> <li>Mechanical characteristics                             <ul style="list-style-type: none"> <li>Options</li> </ul> </li> <li>Excitation system                             <ul style="list-style-type: none"> <li>R448 AVR characteristics</li> <li>R 448 power supply connection</li> <li>Frequency compared with voltage</li> <li>LAM characteristics</li> <li>Typical effects of the LAM</li> <li>R 448 AVR options</li> </ul> </li> </ul> <p><b>3 - INSTALLATION ..... 8</b></p> <ul style="list-style-type: none"> <li>Assembly                             <ul style="list-style-type: none"> <li>Handling</li> <li>Coupling</li> <li>Location</li> </ul> </li> <li>Inspection prior to first use                             <ul style="list-style-type: none"> <li>Electrical checks</li> <li>Mechanical checks</li> </ul> </li> <li>Terminal connection diagrams                             <ul style="list-style-type: none"> <li>Terminal connection : LSA 46.2/47.1 - 12-wire</li> <li>Terminal connection : LSA 46.2/47.1 - 6-wire</li> <li>Option connection diagram</li> <li>Connection checks</li> <li>Electrical checks on the AVR</li> </ul> </li> <li>Commissioning</li> <li>Settings                             <ul style="list-style-type: none"> <li>R 448 settings</li> <li>Max. excitation setting</li> <li>Special type of use</li> </ul> </li> </ul>	<p><b>4 - SERVICING - MAINTENANCE ..... 15</b></p> <ul style="list-style-type: none"> <li>Safety measures</li> <li>Regular maintenance                             <ul style="list-style-type: none"> <li>Checks after start-up</li> <li>Cooling circuit</li> <li>Bearings</li> <li>Electrical servicing</li> <li>Mechanical servicing</li> <li>Fault detection</li> </ul> </li> <li>Mechanical defects</li> <li>Electrical faults                             <ul style="list-style-type: none"> <li>Checking the winding</li> <li>Checking the diode bridge</li> <li>Checking the windings and rotating diodes using separate excitation</li> </ul> </li> <li>Dismantling, reassembly                             <ul style="list-style-type: none"> <li>Tools required</li> <li>Screw tightening torque</li> <li>Access to diodes</li> <li>Access to connections and the regulation system</li> <li>Replacing the NDE bearing on single-bearing machines</li> <li>Replacing the DE bearing on two-bearing machines</li> <li>Complete dismantling</li> <li>Reassembling the bearings</li> <li>Reassembling the rotor</li> </ul> </li> <li>Installation and maintenance of the PMG                             <ul style="list-style-type: none"> <li>Mechanical characteristics</li> <li>Electrical connection</li> </ul> </li> <li>Table of characteristics                             <ul style="list-style-type: none"> <li>Average values for LSA 46.2</li> <li>Average values for LSA 47.1</li> </ul> </li> </ul> <p><b>5 - SPARE PARTS ..... 23</b></p> <ul style="list-style-type: none"> <li>Technical support service</li> <li>Accessories                             <ul style="list-style-type: none"> <li>Space heater for use when stopped</li> <li>Stator thermistor temperature probes (PTC)</li> <li>Connection accessories</li> </ul> </li> <li>Exploded views, parts list                             <ul style="list-style-type: none"> <li>Single bearing</li> <li>Two-bearing</li> </ul> </li> </ul>
---	---



# LSA 46.2 / 47.1 ALTERNATORS

## TECHNICAL CHARACTERISTICS

## 2 - TECHNICAL CHARACTERISTICS

### 2.1 - Electrical characteristics

LSA 46.2/47.1 alternators are machines without sliprings or revolving field brushes, wound as « 2/3 pitch»; 6 or 12-wire, with class H insulation and a field excitation system available in either AREP or "PMG" version (see diagrams).

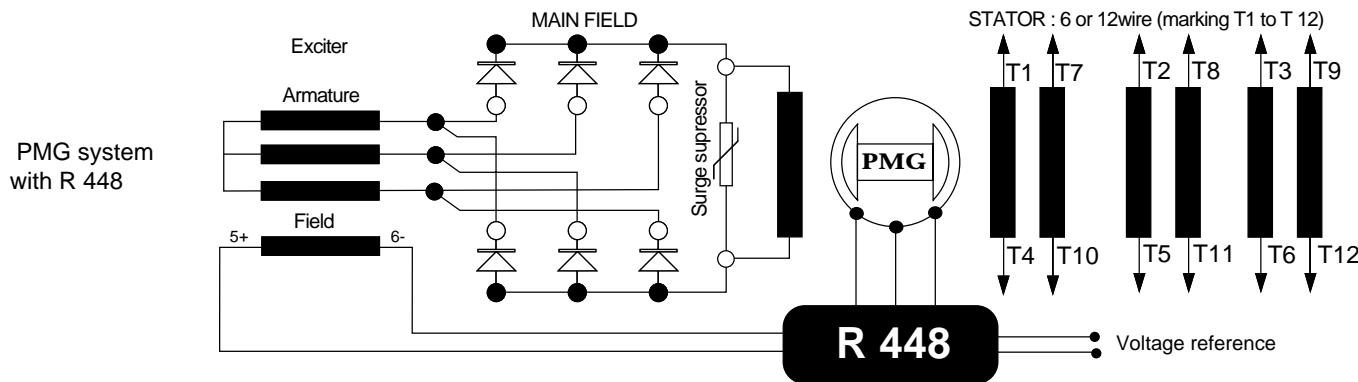
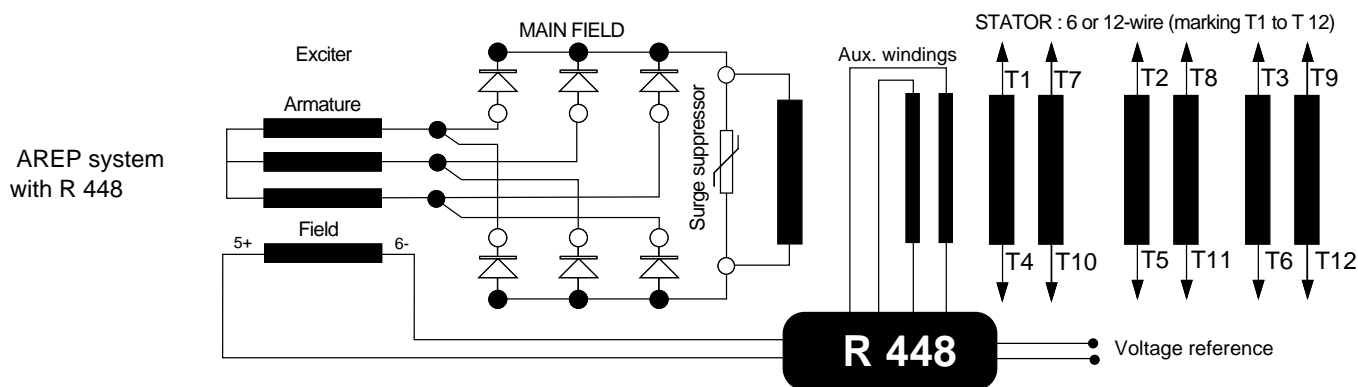

Interference suppression conforms to standard EN 55011, group 1, class B.

#### 2.1.1 - Options

- Stator temperature detection probes
- Space heaters

#### B 34 :

- two-bearing with SAE flange and standard cylindrical shaft extension.
- Drip-proof machine, self-cooled
- Degree of protection : IP 21

### 2.2 - Mechanical characteristics

- Steel frame
- Cast iron end shields
- Ball bearings greased for life
- Mounting arrangement

MD 35 :

single bearing with standard feet and SAE flanges/coupling discs.

#### 2.2.1 - Options

- IP 23,
- Air inlet filter,
- Greasable ball bearings,
- IP 44,
- Bearing probes,
- PT 100 stators.

# LSA 46.2 / 47.1 ALTERNATORS

## TECHNICAL CHARACTERISTICS

### 2.3 - Excitation system

For both the AREP & PMG excitation systems, the alternator voltage regulator is the R 448.

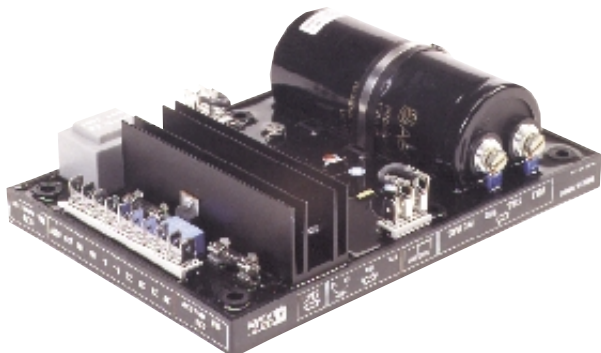

With **AREP** excitation, the electronic AVR is powered by two auxiliary windings which are independent of the voltage detection circuit. The first winding (X1, X2) has a voltage proportional to that of the alternator (Shunt characteristic), the second (Z1, Z2) has a voltage in proportion with the stator current (compound characteristic : Booster effect). The power supply voltage is rectified and filtered before being used by the AVR monitoring transistor. As a result the machine has a short-circuit current capacity of 3 IN for 10 s, and good immunity to distortions generated by the load.

With **PMG** excitation, a permanent magnet generator (PMG) is added to the alternator. This is fitted at the rear of the machine and connected to the AVR. The PMG supplies the AVR with voltage which is independent of the main alternator winding. As a result the machine has a short-circuit current capacity of 3 IN for 10 s, and good immunity to distortions generated by the load.

The AVR monitors and corrects the alternator output voltage by adjusting the excitation current.

#### 2.3.1 - R448 AVR characteristics

- shunt power supply : max 140V - 50/60 Hz
- rated overload current : 10A - 10s
- electronic protection (overload, voltage detection opening short-circuit): excitation overload current for 10 s then return to approximately 1A

The alternator must be stopped (or the power switched off, see section 3.5.3.) in order to reset the protection.

- Fuse :

- F1 on X1,X2.

- voltage detection : 5 VA isolated via transformer
- 0-110 V terminals = 95 to 140 V
- 0-220 V terminals = 170 to 260 V
- 0-380 V terminals = 340 to 520 V

- voltage regulation  $\pm 0.5\%$
- normal or rapid response time via strap ST2
- voltage adjustment via potentiometer P2
- other voltages via adapter transformer
- current detection : (parallel operation) : C.T. 2.5 VA cl1, secondary 1A (Option)
- quadrature droop adjustment via potentiometer P1
- underspeed protection (U/f) and LAM : frequency threshold

- adjustable via potentiometer P4
- max. excitation current adjustment via P5 : 4 to 10A
- 50/60 Hz selection via strap ST3.

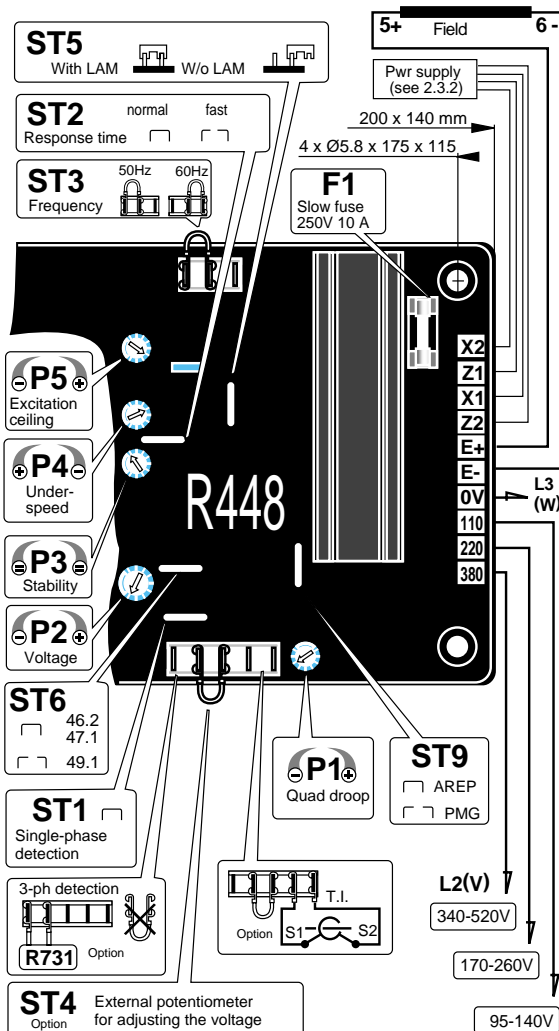

#### 2.3.2 - R 448 power supply connection

AREP excitation

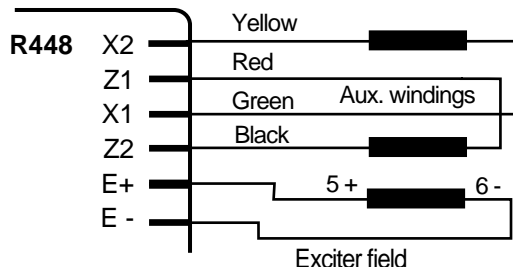

# LSA 46.2 / 47.1 ALTERNATORS

## TECHNICAL CHARACTERISTICS

PMG excitation

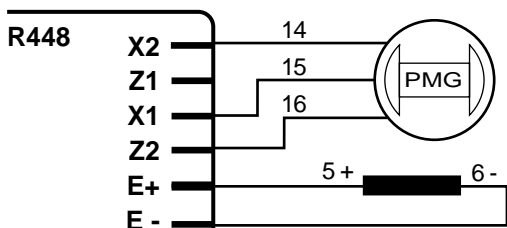

### 2.3.3 - Frequency compared with voltage (without LAM)

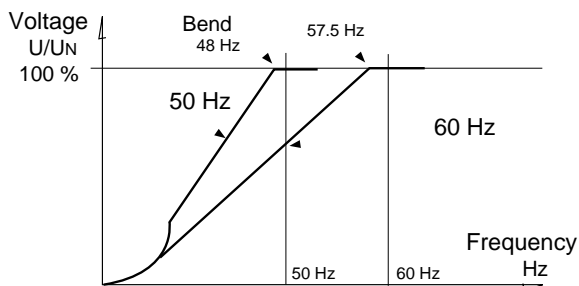

### 2.3.4 - LAM characteristics

The LAM system is integrated in the regulator, as standard it is active (ST5 with bridge). It can be deactivated by removing the ST5 bridge.

- Role of the "LAM" (Load Adjustment Module) :

On application of a load, the rotation speed of the generator set decreases. When it passes below the preset frequency threshold, the LAM causes the voltage to drop by approximately 15% and consequently the amount of active load applied is reduced by approximately 25%, until the speed reaches its rated value again.

Hence the LAM can be used either to reduce the speed variation (frequency) and its duration for a given applied load, or to increase the applied load possible for one speed variation (turbo-charged engine).

To avoid voltage oscillations, the trip threshold for the LAM function should be set approximately 2 Hz below the lowest frequency in steady state.

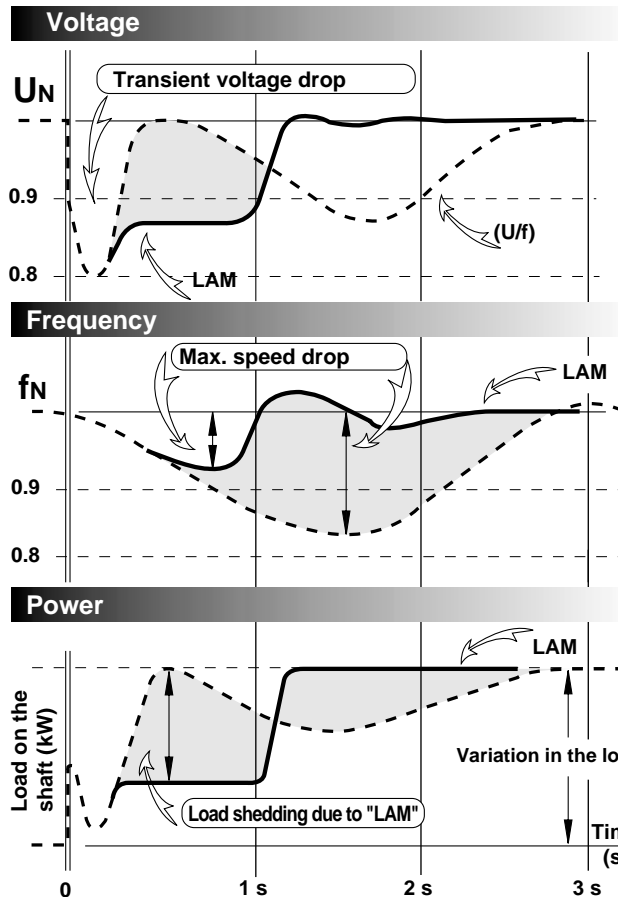
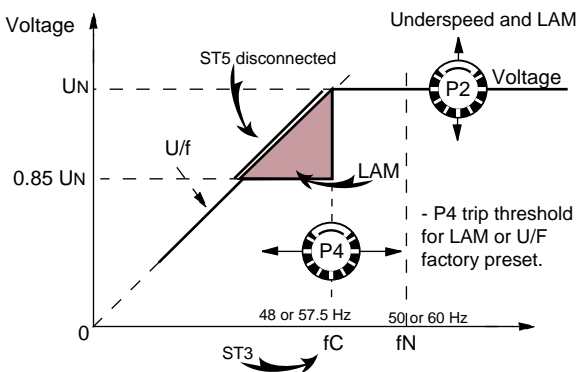

Typical effects of the "LAM" with a diesel engine -  
— with LAM ···· without LAM (U/F only)

### 2.3.5 - R 448 AVR options

- **Current transformer for parallel operation**  
of...../1 A -2.5 VA CL 1 (See the diagram included with this manual).

- **Remote voltage adjustment potentiometer :**  
470 Ω, 3 W min. : adjustment range ± 5% (range limited by internal voltage potentiometer P2). Remove ST4 to connect the potentiometer. (A 1 k Ω potentiometer can also be used to extend the adjustment range by ± 10%)

- **R 731 module :** detection of 3-phase voltage 200 to 500V, compatible with parallel operation. Cut ST1 to connect the module; set the voltage via the module potentiometer.

- **R 726 module :** regulation system changed to "4-function" (See the maintenance manual and connection diagram).

- PF regulation (2F)
- equalization of voltages before paralleling (3 F).
- possibility of coupling alternators, already running in parallel, to the mains (4F).

R 726 module connected in place of ST4.

# LSA 46.2 / 47.1

## ALTERNATORS

### INSTALLATION

## 3 - INSTALLATION

### 3.1 - Assembly



All mechanical handling operations must be undertaken using approved equipment. Whilst being handled, the machine should remain horizontal.

#### 3.1.1 - Handling

The generously-sized lifting rings are for handling the alternator alone. They must not be used to lift the genset. Use a lifting system which respects the positioning of the rings.

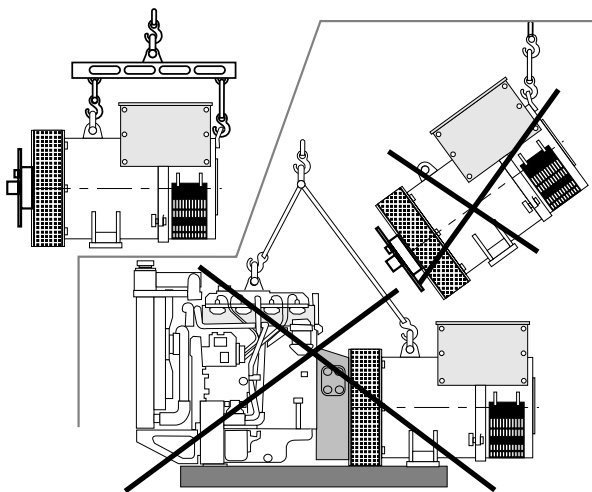

#### 3.1.2 - Coupling

##### 3.1.2.1 - single bearing alternator

Before coupling the two machines, check that both are compatible by :

- undertaking a torsional analysis of the transmission
- checking the dimensions of the flywheel and its housing, the flange, coupling discs and the offset of the alternator

### WARNING

When coupling the alternator to the prime mover, the holes of the coupling discs should be aligned with the flywheel holes by rotating the primary pulley on the thermal engine.

Do not use the alternator fan to turn the rotor.

Tighten the coupling disc screws to the recommended torque (see section 4.6.2.) and check that there is lateral play on the crankshaft.

##### 3.1.2.2 - two-bearing alternator

- Semi-flexible coupling

Careful alignment of the machines is recommended, checking that the concentricity and parallelism of both parts of the coupling does not exceed 0.1 mm.

### WARNING

This alternator has been balanced with a 1/2 key.

#### 3.1.3 - Location

Ensure that the ambient temperature in the room where the alternator is placed cannot exceed 40°C for standard power ratings (for temperatures > 40°C, apply a derating coefficient). Fresh air, free from damp and dust, must be able to circulate freely around the air intake grilles on the opposite side from the coupling. It is essential to prevent not only the recycling of hot air from the machine or engine, but also exhaust fumes.

### 3.2 - Inspection prior to first use

#### 3.2.1 - Electrical checks



Under no circumstances should an alternator, new or otherwise, be operated if the isolation is less than 1 megohm for the stator and 100,000 ohms for the other windings.

There are three possible methods for restoring these minimum values.

- Dry out the machine for 24 hours in a drying oven at a temperature of 110 °C (without the AVR)
- Blow hot air into the air intake, having made sure that the machine is rotating with the exciter field disconnected.
- Run in short-circuit mode (disconnect the AVR) :
  - Short-circuit the three output power terminals using connections capable of supporting the rated current (try not to exceed 6 A/mm<sup>2</sup>)
  - Insert a clamp ammeter to monitor the current passing through the short-circuit connections.
  - Connect a 24 Volt battery in series with a rheostat of approximately 10 ohms (50 W) to the exciter field terminals, respecting the polarity.
  - Open fully all the alternator openings.
  - run the alternator at its rated speed, and adjust the exciter field current using the rheostat to obtain the rated output current in the short-circuit connections.

Note : Prolonged standstill : In order to avoid these problems, we recommend the use of space heaters, as well as turning over the machine from time to time. Space heaters are only really effective if they are working continuously while the machine is stopped.

#### 3.2.2 - Mechanical checks

Before starting the machine for the first time, check that :

- all fixing bolts and screws are tight
  - cooling air is drawn in freely
  - the protective louvres and housing are correctly positioned
  - the standard direction of rotation is clockwise as seen from the shaft end (phase rotation in order 1 - 2 - 3).
- For anti-clockwise rotation, swap 2 and 3.
- the winding connection corresponds to the site operating voltage (see section 3.3)

# LSA 46.2 / 47.1 ALTERNATORS INSTALLATION

## 3.3 - Terminal connection diagrams

To modify the connections, change the position of the terminal links or shunts. The winding code is specified on the nameplate.



**Any intervention on the alternator terminals during reconnection or checks should be performed with the machine stopped.**

### 3.3.1 - Terminal connection : LSA 46.2/47.1 - 12-wire

The connection accessories are detailed in section 5.3.3.

Connection codes	Voltage L.L			Factory connection
<b>(A)</b> 3-phase 	Winding	50 Hz	60 Hz	LSA 46.2/47.1 - 12-WIRE 
	6	190 - 208	190 - 240	
	7	220	-	
	8	-	190 - 208	
R 448 voltage detection : 0 => (T3) / 220 V => (T2)				
<b>(D)</b> 3-phase 	Winding	50 Hz	60 Hz	LSA 46.2/47.1 - 12-WIRE 
	6	380 - 415	380 - 480	
	7	440	-	
	8	-	380 - 416	
R 448 voltage detection : 0 => (T3) / 380 V => (T2)				
Winding 9 : R 448 voltage detection + transformer (See specific diagram)				
<b>(FF)</b> 1 phase <p>Voltage LM = 1/2 voltage LL</p>	Winding	50 Hz	60 Hz	LSA 46.2 - 12-WIRE <b>(*)</b> 
	6	220 - 240	220 - 240	
	7	240 - 254	-	
	8	-	220 - 240	
R 448 voltage detection : 0 => (T10) / 220 V => (T1)				
<b>(F)</b> 1 phase or 3-phase <p>Voltage LM = 1/2 voltage LL</p>	Winding	50 Hz	60 Hz	LSA 46.2/47.1 - 12-WIRE <b>(*)</b> 
	6	220 - 240	220 - 240	
	7	240 - 254	-	
	8	-	220 - 240	
R 448 voltage detection : 0 => (T3) / 220 V => (T2) Operating phases L2 (V), L3 (W) single phase				



**In case of reconnection, ensure that AVR voltage detection is correct !**

# LSA 46.2 / 47.1 ALTERNATORS INSTALLATION

## 3.3.2 - Terminal connection : LSA 46.2/47.1 - 6-wire

Connection codes	Voltage L.L	Factory connection												
<p><b>(D)</b> 3-phase</p>	<table border="1" style="width: 100%; border-collapse: collapse;"> <tr> <th>Winding</th> <th>50 Hz</th> <th>60 Hz</th> </tr> <tr> <td>7S</td> <td>440</td> <td>-</td> </tr> <tr> <td>8S</td> <td>-</td> <td>380 - 416</td> </tr> <tr> <td>9S</td> <td></td> <td>600</td> </tr> </table>	Winding	50 Hz	60 Hz	7S	440	-	8S	-	380 - 416	9S		600	<p>LSA 46.2 - 6-WIRE</p>
	Winding	50 Hz	60 Hz											
	7S	440	-											
	8S	-	380 - 416											
9S		600												
<p><b>(F)</b> 1 phase or 3-phase</p>	<table border="1" style="width: 100%; border-collapse: collapse;"> <tr> <th>Winding</th> <th>50 Hz</th> <th>60 Hz</th> </tr> <tr> <td>7S</td> <td>240 - 254</td> <td>-</td> </tr> <tr> <td>8S</td> <td>-</td> <td>220 - 240</td> </tr> </table>	Winding	50 Hz	60 Hz	7S	240 - 254	-	8S	-	220 - 240	<p>LSA 46.2 - 6-WIRE</p>			
Winding	50 Hz	60 Hz												
7S	240 - 254	-												
8S	-	220 - 240												
<p><b>(D)</b> 3-phase</p>	<table border="1" style="width: 100%; border-collapse: collapse;"> <tr> <th>Winding</th> <th>50 Hz</th> <th>60 Hz</th> </tr> <tr> <td>6S</td> <td>380 - 415</td> <td>380 - 480</td> </tr> <tr> <td>7S</td> <td>440</td> <td>-</td> </tr> <tr> <td>8S</td> <td>-</td> <td>380 - 416</td> </tr> </table>	Winding	50 Hz	60 Hz	6S	380 - 415	380 - 480	7S	440	-	8S	-	380 - 416	<p>LSA 47.1 - 6-WIRE</p>
Winding	50 Hz	60 Hz												
6S	380 - 415	380 - 480												
7S	440	-												
8S	-	380 - 416												
<p><b>(F)</b> 1 phase or 3-phase</p>	<table border="1" style="width: 100%; border-collapse: collapse;"> <tr> <th>Winding</th> <th>50 Hz</th> <th>60 Hz</th> </tr> <tr> <td>6S</td> <td>220 - 240</td> <td>220 - 277</td> </tr> <tr> <td>7S</td> <td>240 - 254</td> <td>-</td> </tr> <tr> <td>8S</td> <td>-</td> <td>220 - 240</td> </tr> </table>	Winding	50 Hz	60 Hz	6S	220 - 240	220 - 277	7S	240 - 254	-	8S	-	220 - 240	<p>LSA 47.1 - 6-WIRE</p>
Winding	50 Hz	60 Hz												
6S	220 - 240	220 - 277												
7S	240 - 254	-												
8S	-	220 - 240												
<p><b>⚠ In case of reconnection, ensure that the AVR voltage detection is correct !</b></p>														

(\*) The factory can supply a set of flexible shunts and special connection links as an option for making these connections. The standard alternator is fitted with 3 starting ranges, 6 connection links and one neutral link.

# LSA 46.2 / 47.1 ALTERNATORS INSTALLATION

### 3.3.3 - Option connection diagram

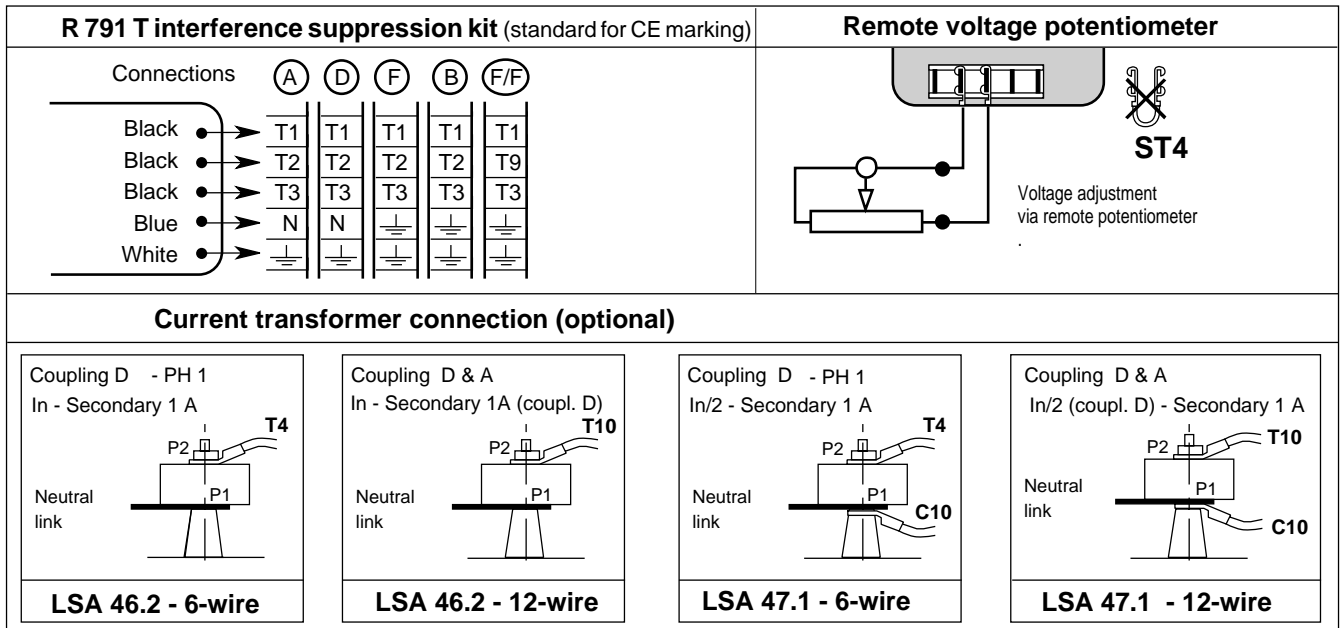

### 3.3.4 - Connection checks



**Electrical installations must comply with the current legislation in the country of use.**

Check that :

- the residual circuit-breaker conforms to legislation on protection of personnel, in force in the country of use, and has been correctly installed on the alternator power output as close as possible to the alternator. (In this case, disconnect the wire of the interference suppression module linking the neutral).
- Any protective devices in place have not been tripped.
- If there is an external AVR , the connections between the alternator and the cubicle are made in accordance with the connection diagram.
- There is no short-circuit between phase or phase-neutral between the alternator output terminals and the generator set control cabinet (part of the circuit not protected by circuit-breakers or cubicle relays).
- The machine should be connected with the busbar separating the terminals as shown in the terminal connection diagram.

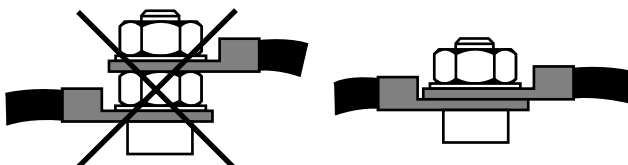

### 3.3.5 - Electrical checks on the AVR

- Check that all connections have been made properly as shown in the attached connection diagram.

- Check that the frequency selection strap “ST3” is on the correct frequency setting.
- Check whether strap ST4 or the remote adjustment potentiometer have been connected.
- Optional operating modes
  - Strap ST1 : cut to connect the R 731 3-phase detection module.
  - Strap ST2 : cut for rapid response time
  - Strap ST5 : cut to suppress the LAM function.

# LSA 46.2 / 47.1 ALTERNATORS INSTALLATION

## 3.4 - Commissioning



The machine can only be started up and used if the installation has been set up in accordance with the regulations and instructions defined in this manual.

The machine is tested and set at the factory. When first used with no load, make sure that the drive speed is correct and stable (see the nameplate). With the greaseable ball bearings option, we recommend greasing the bearings at the time of commissioning (see 4.2.3).

On application of the load, the machine should achieve its rated speed and voltage; however, in the event of abnormal operation, the machine setting can be altered (follow the adjustment procedure in section 3.5). If the machine still operates incorrectly, the cause of the malfunction must be located (see section 4.4).

## 3.5 - Settings



The various adjustments during tests must be made by a qualified engineer.



Take care that the drive speed specified on the nameplate is reached before commencing adjustment

**1500 min<sup>-1</sup> / 50Hz or 1800 min<sup>-1</sup> / 60 Hz.**

Do not try to set the voltage if the frequency or speed is not correct (risk of irreparable rotor damage).



After operational testing, replace all access panels or covers.

The AVR should be used to make any adjustments to the machine.

## 3.5.1 - R 448 settings

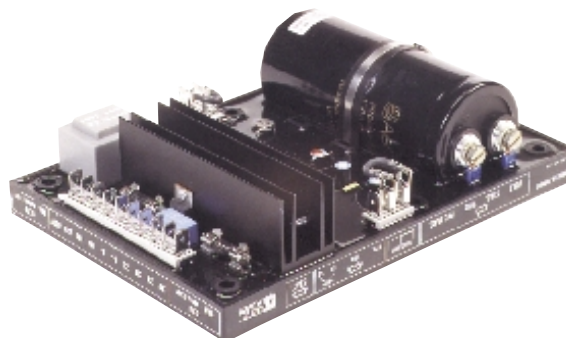

a) Initial potentiometer settings (see table below)  
- Remote voltage adjustment potentiometer : centre (strap ST4 removed).

Action	Factory setting	Pot.
<b>Voltage</b> minimum fully anti-clockwise	400V - 50 Hz (Input 0 - 380 V)	
<b>Stability</b>	Not set (centre position)	
<b>Threshold/LAM or U/F</b> Underspeed protection and "LAM" trip threshold Maximum frequency fully anti-clockwise	If ST3 = 50 Hz (factory) = 48 Hz If ST3 = 60 Hz (factory) = 58 Hz	
<b>Voltage quadrature droop</b> (// operation with C.T.) - 0 quadrature droop fully anti-clockwise.	Not set (fully anti- clockwise)	
<b>Excitation ceiling</b> Limit of excitation and short-circuit current, minimum fully anti-clockwise	10 A maximum	

# LSA 46.2 / 47.1 ALTERNATORS INSTALLATION

### Adjustments in standalone operation

b) Install a D.C. analogue voltmeter (needle dial) cal. 100V on terminals E+, E- and an A.C. voltmeter cal 300 - 500 or 1000V on the alternator output terminals.

c) Make sure that strap ST3 is positioned on the desired frequency (50 or 60 Hz).

d) Voltage potentiometer P2 at minimum, fully anti-clockwise.

e) Turn the V/Hz potentiometer P4 fully clockwise.

f) Stability potentiometer P3 to approximately 1/3 anti-clockwise turn.

g) Start the engine and set its speed to a frequency of 48 Hz for 50 Hz, or 58 for 60 Hz.

h) Set the output voltage to the desired value using P2.

- Rated voltage UN for solo operation (eg. 400 V)

- Or UN + 2 to 4% for parallel operation with C.T. (eg. 410 V)  
If the voltage oscillates, use P3 to make adjustments (try both directions) observing the voltage between E+ and E- (approx. 10V D.C.). The best response times are obtained at the limit of the instability. If no stable position can be obtained, try cutting or replacing strap ST2 (normal/fast).

i) Check LAM operation : ST5 closed.

j) Turn potentiometer P4 slowly anti-clockwise until there is a significant voltage drop (approximately 15%)

k) Vary the frequency (speed) around 48 or 58 Hz according to the operating frequency, and check the change in voltage from that observed previously (approximately 15%).

l) Readjust the speed of the unit to its rated no-load value.

### Adjustments in parallel operation

**WARNING**

**Before any intervention on the alternator, make sure that the speed droop is identical for all engines.**

m) Preset for parallel operation (with C.T. connected to S1, S2 on connector J2)

- Potentiometer P1 (quadrature droop) in centre position. Apply the rated load (cos Ø = 0.8 inductive).

The voltage should drop by 2 to 3%. If it increases, swap the 2 incoming wires from the C.T. secondary.

n) The no-load voltages should be identical for all the alternators intended to run in parallel.

- Couple the machines in parallel.

- By adjusting the speed, try to obtain 0 KW power exchange.

- By altering the voltage setting P2 or Rhe on one of the

machines, try to cancel (or minimise) the current circulating between the machines.

### From now on, do not touch the voltage settings.

o) Apply the available load (the setting is only correct if a reactive load is available)

- By altering the speed, equalise the KW (or divide the rated power of the units proportionally)

- By altering the quadrature droop potentiometer P1, equalise or divide the currents.

### 3.5.2 - Max. excitation setting (excitation ceiling)

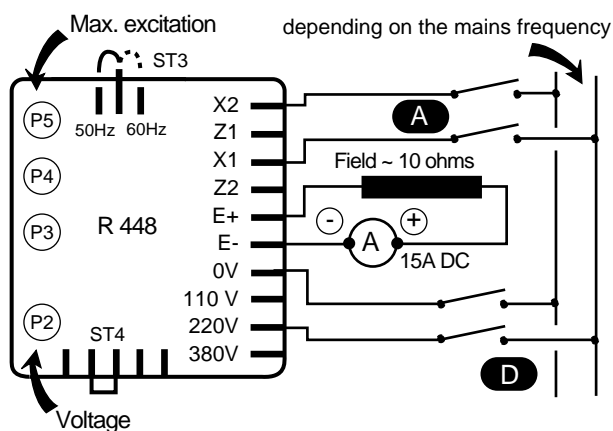

### Adjustment of the current limit

via potentiometer P5 (fuse rating : 8A-10 seconds).

The maximum factory setting corresponds to that of the excitation current required to obtain a 3-phase short-circuit current of approximately 3 IN at 50 Hz for industrial power, unless otherwise specified(\*).

A static method can be used to reduce this value or adapt the Isc to the actual max. operating power (derated machine), which is safer for the alternator and the installation.

Disconnect power supply wires X1,X2 and Z1,Z2 and the voltage reference (0-110V-220V-380V) on the alternator.

Connect the mains power supply (200-240V) as indicated (X1,X2). Install a 10A D.C. ammeter in series with the exciter field. Turn P5 fully anti-clockwise and activate the power supply. If there is no output current from the AVR, turn potentiometer P2 (voltage) clockwise until the ammeter indicates a stable current. Switch the power supply off, then on again, turn P5 clockwise until the required max. current is obtained (no more than 10 A).

# LSA 46.2 / 47.1 ALTERNATORS INSTALLATION

### Checking the internal protection :

Open switch (D): the excitation current should increase to its preset ceiling, remain at that level for  $\geq 10$  seconds and then drop to  $< 1A$ .

To reset, switch off the power supply by opening switch (A).

Note : After setting the excitation ceiling as described, adjust the voltage again

( see section 3.5.2.) via P2.

(\*): In some countries it is a legal requirement to have a short-circuit current, so as to offer discriminating protection.

### 3.5.3 - Special type of use

- Field weakening

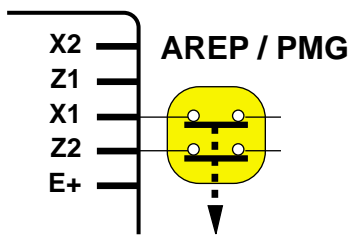

The exciter is switched off by disconnecting the AVR power supply (1 wire on each auxiliary winding) – contact rating 16 A - 250V A.C.

Connection is identical for resetting the AVR internal protection

- Field forcing

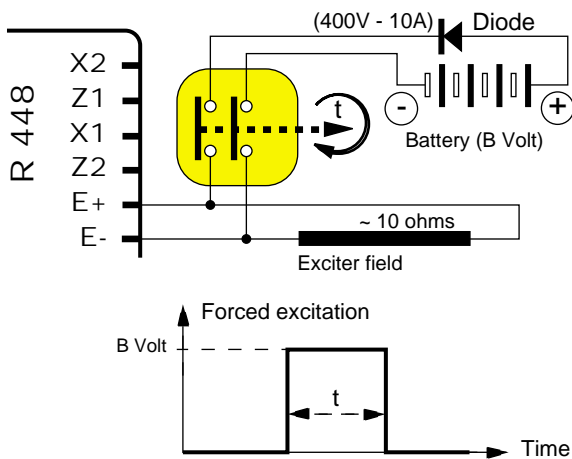

Applications	B volts	Time t
Guaranteed voltage build-up	12 (1A)	1 - 2 s
Parallel operation, de-energized	12 (1A)	1 - 2 s
Parallel operation, at standstill	24 (2A)	5 - 10 s
Frequency starting	48 (4A)	5 - 10 s
Sustained voltage on overload	48 (4A)	5 - 10 s

# LSA 46.2 / 47.1

## ALTERNATORS

### SERVICING - MAINTENANCE

## 4 - SERVICING - MAINTENANCE

### 4.1 - Safety measures



**Servicing or troubleshooting must be carried out strictly in accordance with instructions so as to avoid the risk of accidents and to maintain the machine in its original condition.**



**All such operations performed on the alternator should be undertaken by personnel trained in the commissioning, servicing and maintenance of electrical and mechanical components.**

Before any intervention on the machine, ensure that it cannot be started by a manual or automatic system and that you understand how the operating system works.

### 4.2 - Regular maintenance

#### 4.2.1 - Checks after start-up

After approximately 20 hours of operation, check that all fixing screws on the machine are still tight, plus the general condition of the machine and the various electrical connections in the installation.

#### 4.2.2 - Cooling circuit

It is advisable to check that circulation of air is not reduced by partial blocking of the air intake and outlet grilles : mud, fibre, grease, etc.

#### 4.2.3 - Bearings

The bearings are greasable (option). It is advisable to lubricate the machine during operation. Time intervals and quantity of grease are given in the table below.

DE bearing - LSA 46.2	6316 C3
Quantity of grease	33 g
Lubrication interval	4000 H

NDE bearing - LSA 46.2/ 47.1	6315 C3
Quantity of grease	30 g
Lubrication interval	4500 H

DE bearing - LSA 47.1	6318 C3
Quantity of grease	41 g
Lubrication interval	3500 H

Lubrication intervals are given for a grease of grade LITHIUM - standard - NLGI 3.

The factory lubrication is performed with grease :  
SHELL - ALVANIA G3.

Before using another grease, check for compatibility with the original one. Monitor the temperature rise in the bearings, which should not exceed 50°C above the ambient temperature. Should this value be exceeded, the machine must be stopped and checks carried out.

#### 4.2.4 - Electrical servicing

Cleaning product for the windings

### WARNING

**Do not use : trichlorethylene, perchlorethylene, trichloroethane or any alkaline products.**

Certain strictly defined pure volatile degreasing products can be used, such as :

- Normal petrol (without additives)
- Toluene (slightly toxic); inflammable
- Benzene (or benzine, toxic); inflammable
- Cyclohexane (non toxic); inflammable

#### Cleaning of the stator, rotor, exciter and diode bridge

The insulating components and the impregnation system are not at risk of damage from solvents (see the above list of authorised products).

Avoid letting the cleaning product run into the slots. Apply the product with a brush, sponging frequently to avoid accumulation in the housing. Dry the winding with a dry cloth. Let any traces evaporate before reassembling the machine.

#### 4.2.5 - Mechanical servicing

### WARNING

**Cleaning the machine using water or a high-pressure washer is strictly prohibited.**

**Any problems arising from such treatment are not covered by our warranty.**

Degreasing : Use a brush and detergent (suitable for paintwork).

Dusting : Use an air gun.

If filters have been added to the machine after manufacture and do not have thermal protection, the service personnel should clean the air filters periodically and systematically, as often as is necessary (every day in very dusty atmospheres). Cleaning can be performed using water for dry dust or in a bath containing soap or detergent in the case of greasy dust. Petrol or chlorethylene can also be used.

After cleaning the alternator, it is essential to check the winding insulation (see sections 3.2. and 4.8.).

# LSA 46.2 / 47.1 ALTERNATORS SERVICING - MAINTENANCE

### 4.3 - Fault detection

If, when commissioned, the alternator does not work normally, the source of the malfunction must be identified.

To do this, check that :

- the protective devices are fitted correctly
- the connections comply with diagrams in the manuals

supplied with the machine

- the speed of the unit is correct (see section 1.3).

Repeat the operations defined in section 3.

### 4.4 - Mechanical defects

Fault		Action
Bearing	Excessive overheating of one or both bearings (bearing temperature 50°C above the ambient temperature) (With or without abnormal bearing noise)	<ul style="list-style-type: none"> <li>- If the bearing has turned blue or if the grease has turned black, change the bearing.</li> <li>- Bearing not fully locked (abnormal play in the bearing cage).</li> <li>- End shields incorrectly aligned.</li> </ul>
Abnormal temperature	Excessive overheating of alternator frame (more than 40° C above the ambient temperature)	<ul style="list-style-type: none"> <li>- Airflow (inlet-outlet) partially clogged or hot air is being recycled from the alternator or engine</li> <li>- Alternator operating at too high a voltage (&gt; 105% of Un on load)</li> <li>- Alternator overloaded</li> </ul>
Vibrations	Too much vibration	<ul style="list-style-type: none"> <li>- Misalignment (coupling)</li> <li>- Defective mounting or play in coupling</li> <li>- Rotor balancing fault (Engine - Alternator)</li> </ul>
	Excessive vibration and humming noise coming from the machine	<ul style="list-style-type: none"> <li>- Phase imbalance</li> <li>- Stator short-circuit</li> </ul>
Abnormal noise	Alternator damaged by a significant impact, followed by humming and vibration	<ul style="list-style-type: none"> <li>- System short-circuit</li> <li>- Mis-paralleling</li> </ul> <p>Possible consequences</p> <ul style="list-style-type: none"> <li>- Broken or damaged coupling</li> <li>- Broken or bent shaft end.</li> <li>- Shifting and short-circuit of main field</li> <li>- Fan fractured or coming loose on shaft</li> <li>- Irreparable damage to rotating diodes or AVR.</li> </ul>

**LSA 46.2 / 47.1**  
**ALTERNATORS**  
SERVICING - MAINTENANCE

**4.5 - Electrical faults**

Fault	Action	Effect	Check/Cause
No voltage at no load on start-up	Connect a new battery of 4 to 12 volts to terminals E- and E+, respecting the polarity, for 2 to 3 seconds	The alternator builds up and its voltage is still correct when the battery is removed.	- Lack of residual magnetism
		The alternator builds up but its voltage does not reach the rated value when the battery is removed.	- Check the connection of the voltage reference to the AVR - Faulty diode - Armature short-circuit
		The alternator builds up but its voltage disappears when the battery is removed	- Faulty AVR - Field windings open circuit (check winding) - Main field winding open circuit (check the resistance)
Voltage too low	Check the drive speed	Correct speed	Check the AVR connections (possible AVR failure) - Field windings short-circuited - Rotating diodes burnt out - Main field winding short-circuited - Check the resistance
		Speed too low	Increase the drive speed. (Do not touch the AVR voltage pot. (P2) before running at the correct speed.)
Voltage too high	Adjust AVR voltage potentiometer	Adjustment ineffective	Faulty AVR
Voltage oscillations	Adjust AVR stability potentiometer	If no effect : try normal / fast recovery modes (ST2)	- Check the speed : possibility of cyclic irregularity - Loose connections - Faulty AVR - Speed too low when on load (or LAM set too high)
Voltage correct at no load and too low when on load	Run at no load and check the voltage between E+ et E- on the AVR	Voltage between E+ and E- (DC) AREP / PMG < 10V	- Check the speed (or LAM set too high)
		Voltage between E+ and E- AREP / PMG > 15V	- Faulty rotating diodes - Short-circuit in the main field. Check the resistance- Faulty exciter armature. Check the resistance.
Voltage disappears during operation	Check the AVR, the surge suppressor, the rotating diodes, and replace any defective components	The voltage does not return to the rated value.	- Exciter winding open circuit - Faulty exciter armature - Faulty AVR - Main field open circuit or short-circuited

**4.5.1 - Checking the winding**

You can check the winding insulation by performing a high voltage test. In this case, you must disconnect all AVR wires.

**WARNING**

**Damage caused to the AVR in such conditions is not covered by our warranty.**

# LSA 46.2 / 47.1

## ALTERNATORS

SERVICING - MAINTENANCE

### 4.5.2 - Checking the diode bridge

#### DIODE BRIDGE

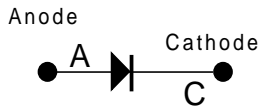

A diode in good working order must allow the current to flow from the anode to the cathode only.

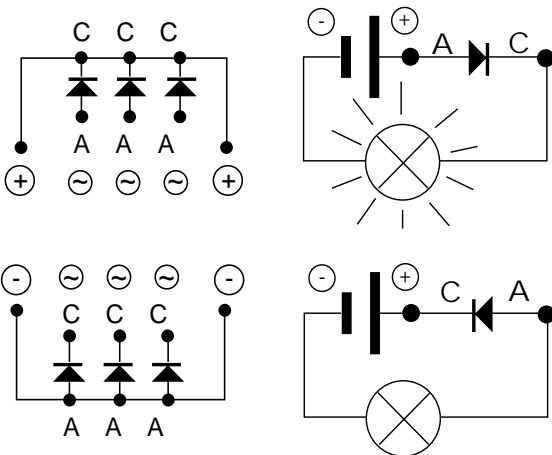

#### ASSEMBLY A

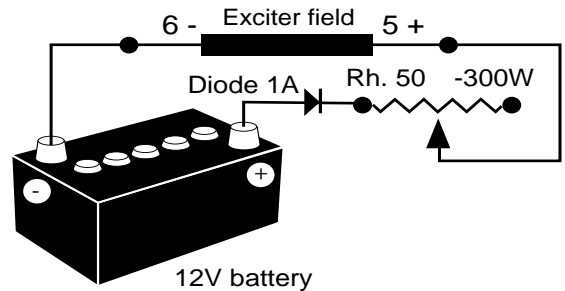

**Assembly B :** Connect a “Variac” variable power supply and a diode bridge on both exciter field wires (5+) and (6-).

Both these systems should have characteristics which are compatible with the machine field excitation power (see the nameplate).

3) Run the unit at its rated speed.

4) Gradually increase the exciter field current by adjusting the rheostat or the variac and measure the output voltages on L1 - L2 - L3, checking the excitation voltage and current at no load and on load (see the machine nameplate or ask for the factory test report).

When the output voltage is at its rated value and balanced within < 1 % for the rated excitation level, the machine is in good working order. The fault therefore comes from the AVR or its associated wiring (ie. sensing, auxiliary windings).

### 4.5.3 - Checking the windings and rotating diodes using separate excitation



During this procedure, make sure that the alternator is disconnected from any external load and inspect the terminal box to check that the connections are fully tightened.

- 1) Stop the unit, disconnect and isolate the AVR wires.
- 2) There are two ways of creating an assembly with separate excitation.

**Assembly A :** Connect a 12 V battery in series with a rheostat of approximately 50 ohms - 300 W and a diode on both exciter field wires (5+) and (6-).

#### ASSEMBLY B

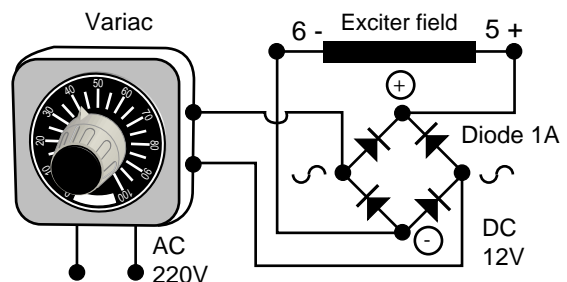

# LSA 46.2 / 47.1 ALTERNATORS SERVICING - MAINTENANCE

## 4.6 - Dismantling, reassembly (see sections 5.4.1. & 5.4.2.)

**WARNING**

During the warranty period, this operation should only be carried out in an approved LEROY-SOMER workshop or in our factory, otherwise the warranty may be invalidated.

Whilst being handled, the machine should remain horizontal (rotor not locked when moved).

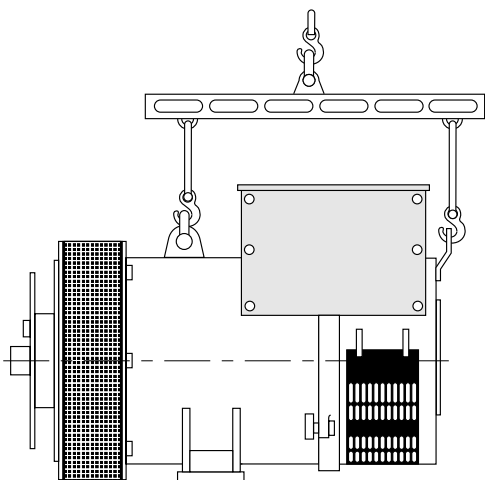

### 4.6.1 - Tools required

To fully dismantle the machine, we recommend using the tools listed below :

- 1 ratchet spanner + extension,
- 1 torque wrench,
- 1 set of flat spanners : 8 mm, 10 mm, 18 mm,
- 1 socket set : 8, 10, 13, 16, 18, 21, 24, 30 mm
- 1 socket with male ferrule : 5 mm,
- 1 puller.

### 4.6.2 - Screw tightening torque

IDENTIFICATION	Screw Ø	Torque N.m
Exciter screw	M 6	10
Star diode bridge	M 6	10
Diode nut	M 6	4
Flange / Frame screw (46.2 S, M)	M 14	80
Flange / Frame screw (46.2 L, VL)	M 14	190
Flange / Frame screw (47.1)	M 16	190
NDE bracket / frame screw	M 12	50
Discs / Sleeve screw	M 16	230
Earth screw	M 10	20
Grille screws	M 6	5
Cover screws	M 6	5
Terminal block nut	M 12	35

### 4.6.3 - Access to diodes

- Open the air inlet louvre (51)
  - Disconnect the diodes.
  - Check the diodes using an ohmmeter or a battery lamp (see section 4-5)
- If the diodes are faulty
- Remove the surge suppressor (347).
  - Remove the 6 "H" mounting nuts for the diode bridges on the support.
  - Change the crescents, respecting the polarity.

### 4.6.4 - Access to connections and the regulation system

Access directly by removing the box lid (48) or the AVR access door (466).

### 4.6.5 - Replacing the NDE bearing on single bearing machines

- Remove the box lid (48) and the NDE panel (365) and remove the 2 screws from the part (122).
- Disconnect the stator outputs (T1 to T12).
- Disconnect the auxiliary winding wires with AREP (X1,X2,Z1,Z2).
- Disconnect the exciter wires (5+,6-).
- Remove the air inlet louvre (51)
- Remove the 2 bearing thrust screws (78).
- Remove all 4 screws (37).
- Remove the bearing (36).
- Remove the ball bearing (70) using a puller with a central screw (see drawing below).

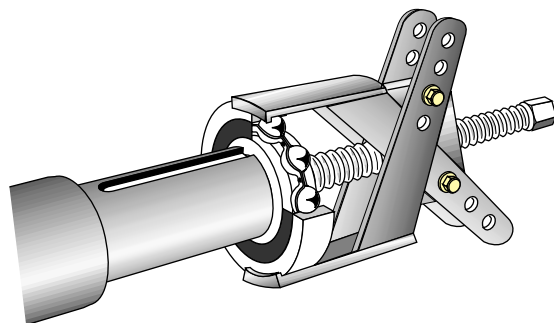

- Check the condition of the "O" ring seal (349) and, if necessary, change it.
- Fit the new bearing, after heating it by induction to approximately 80°C.

**WARNING**

When dismantling the machine, always change the bearings.

# LSA 46.2 / 47.1

## ALTERNATORS

### SERVICING - MAINTENANCE

#### 4.6.6 - Replacing the DE bearing on two-bearing machines

- Remove the screws (31) and (62).
- Remove the shield (30).
- Remove the circlips (284).
- Remove the ball bearing (60) using a puller with a central screw.
- Fit the new bearing, after heating it by induction to approximately 80°C.

### WARNING

When dismantling the machine, always change the bearings.

#### 4.6.7 - Complete dismantling

- Remove the DE shield (30) as described in section 4.6.6.
- Support the DE rotor (4) with a strap or a support constructed as shown in the drawing below.

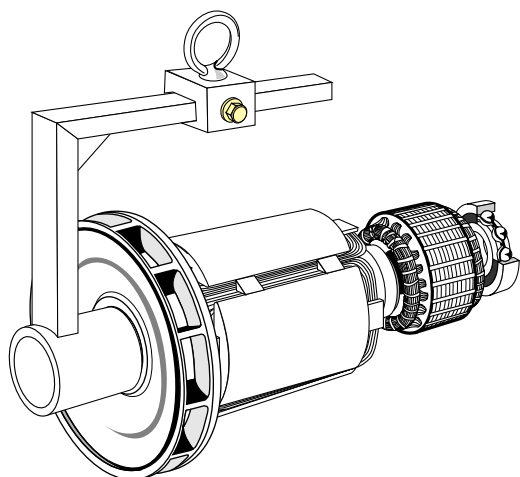

- Remove the NDE shield bearing cover.
- Tap the shaft end lightly on the opposite side from the coupling using a small mallet.
- Pull the strap in order to move the rotor and ensure its weight is evenly supported.
- Remove the NDE shield following the instructions in section 4.6.5.

#### 4.6.8 - Reassembling the end shields

- Place the "O" ring seal (349) and the preloading wavy washer (79) in the bearing seat (36).
- Position shields (30) and (36) on the stator (1).
- Tighten screws (31) and (37).
- Reconnect all the exciter wires, auxiliary windings, stator, etc.
- Fit the 2 support screws (122).
- Fit the air inlet louvre (51)
- Replace the cover.

#### 4.6.9 - Reassembling the rotor

- On single bearing machines :
- Mount the rotor (4) in the stator (1) (see drawing below)
  - Check that the machine is correctly assembled and that all screws are tightened.
- On two-bearing machines :
- Mount the rotor (4) in the stator (1).
  - Position shield (30) on the stator (1).
  - Tighten screws (31).
  - Mount the inner bearing retainer (68) using the screws (62).

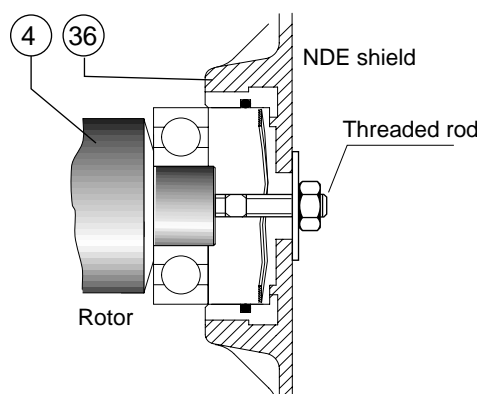

- Mount the circlips (284)
- Check that the machine is correctly assembled and that all screws are tightened.

#### 4.6.10 - Dismantling and reassembly of the filters

- Remove the grille (417) then take out the filter (418) .
- Change the filter, if necessary, please refer to section 4.2.5 for cleaning the filter. To replace follow instructions in reverse order.

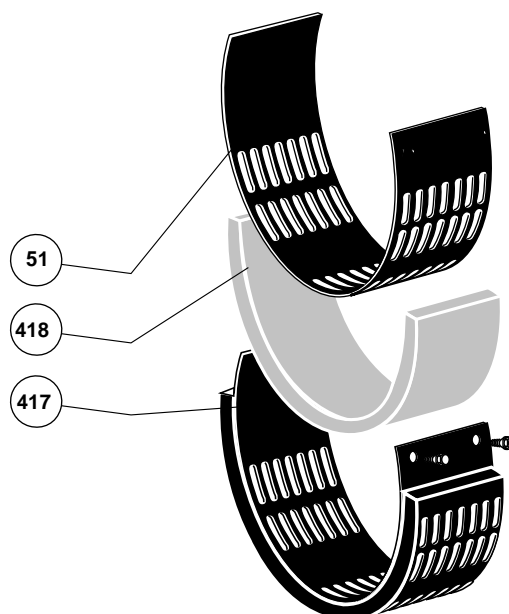

# LSA 46.2 / 47.1

## ALTERNATORS

### SERVICING - MAINTENANCE

### WARNING

When removal of the rotor involves changing parts or rewinding, the rotor must be rebalanced.



After operational testing, replace all access panels or covers.

## 4.7 - Installation and maintenance of the PMG

In LSA 46.2 / 47.1, the PMG reference is : PMG 2.

### 4.7.1 - Mechanical characteristics

The components are :

- an adaptation shaft (to position the rotor on the alternator shaft).
  - an M16 tie rod and nut for assembling the rotor on the shaft.
  - a rotor with 16 magnets.
  - A housing + wound stator + plastic connection sleeve assembly + plastic ferrules.
  - the housing cover (4 CBLXS M5 screws).
  - 4 HM6 screws (mounting housing on the NDE shield).
- If mounting in kit form, follow the instructions below.

- 1 - Remove the PMG cover [297] and the seal (71) on the alternator NDE shield.
- 2 - Mount the PMG housing assembly [290] on the shield using the 4 HM6 screws.
- 3 - Put adhesive on the tie rod [295] and screw it fully into the tapped hole in the alternator shaft extension.
- 4 - Mount the magnetised rotor on the adaptation shaft, then using 2 M10 threaded rods screwed into the rotor slide the assembly onto the tie rod.
- 5 - Once the rotor is in position, remove the 2 M10 rods.
- 6 - Fit the cable gland washer [296].
- 7 - Tighten the assembly with the M16 nut.
- 8 - Close the PMG with the cover [297].
- 9 - Remove the plastic plug on the NDE panel and fit the plastic sleeve and its ferrule.
- 10 - Connect the PMG to the AVR (section 4.7.2.).

### 4.7.2 - Electrical connection

- Connect the 3 PMG wires (14/15/16), the 2 exciter wires (5/6) and the 2 previously mentioned voltage detection wires (2/3) in accordance with the connection diagram (see section 2.3.2).

Mounting the PMG on an AREP machine

- Connect the 3 PMG wires (14/15/16), to terminals X1,X2,Z2

on the AVR. The 4 auxiliary winding wires X1.X2.Z1.Z2 should be isolated using the domino fitting supplied with the kit. Both exciter field wires (5/6) and the voltage sensing wires (2/3) remain in place.

Electrical characteristics of the PMG 2

Stator phase/phase resistance 20°C : 2.1 Ω

No-load A.C. voltage between phases at 1500 rpm : 125 V.

### ATTENTION

With the PMG, check that strap ST9 has been disconnected.

### 4.7.3 - Exploded view of the PMG

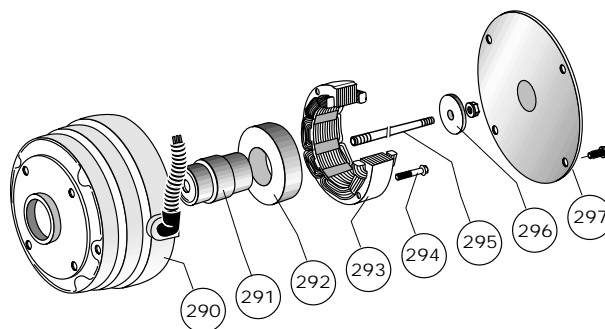

# LSA 46.2 / 47.1

## ALTERNATORS

### SERVICING - MAINTENANCE

#### 4.8 - Table of characteristics

Table of average values

Alternator - 4 poles - 50 Hz - Standard winding No. 6.  
(400V for the excitation values)

The voltage and current values are given for no-load operation and operation at rated load with separate field excitation. All values are given at  $\pm 10\%$  and may be changed without prior notification (for exact values, consult the test report).

##### 4.8.1 - Average values for LSA 46.2

Resistances at 20°C ( $\Omega$ )

LSA 46.2	Stator L/N	Rotor	Field	Armature
M3	0.022	0.23	8.8	0.035
M5	0.0182	0.24	8.8	0.035
L6	0.0148	0.264	8.8	0.035
L9	0.012	0.295	8.8	0.035
VL12	0.0085	0.343	10	0.037

Resistance of AREP auxiliary windings at 20°C ( $\Omega$ )

LSA 46.2	Auxil wdg : X1, X2	Auxil wdg : Z1, Z2
M3	0.24	0.4
M5	0.215	0.36
L6	0.185	0.36
L9	0.19	0.32
VL12	0.17	0.32

Field excitation current  $i_{exc}$  (A)

Symbols : " $i_{exc}$ ": excitation current of the exciter field.

LSA 46.2	No load	At rated load
M3	1.1	4
M5	1.1	3.8
L6	1.1	4.1
L9	1.2	4
VL12	1.1	3.5

For 60 Hz machines, the " $i_{exc}$ " values are approximately 5 to 10 % lower.

##### 4.8.2 - Average values for LSA 47.1

Resistances at 20°C ( $\Omega$ )

LSA 47.1	Stator L/N	Rotor	Field	Armature
M4	0.0108	0.8	10.2	0.13
M6	0.0081	0.9	10.2	0.13
L9	0.006	1.04	10.2	0.13
L10	0.0053	1.1	10.2	0.13
L11	0.0053	1.1	10.2	0.13
VL 12	0.0028	1.13	10.2	0.13

Resistance of AREP auxiliary windings at 20°C ( $\Omega$ )

LSA 47.1	Auxil wdg : X1, X2	Auxil wdg : Z1, Z2
M4	0.23	0.405
M6	0.21	0.335
L9	0.175	0.34
L10	0.173	0.29
L11	0.173	0.29
VL 12	0.18	0.325

Field excitation current  $i_{exc}$  (A)

Symbols : " $i_{exc}$ ": excitation current of the exciter field.

LSA 47.1	No load	At rated load
M4	0.9	3.8
M6	0.9	3.5
L9	0.9	3.2
L10	0.9	3.4
L11	0.9	3.7
VL 12	0.9	3.45

For 60 Hz machines, the " $i_{exc}$ " values are approximately 5 to 10 % lower.

##### 4.8.3 - Voltage of auxiliary windings at no load

LSA 46.2	Auxil wdg : X1, X2	Auxil wdg : Z1, Z2
50 Hz	70 V	10 V
60 Hz	85 V	12 V

LSA 47.1	Auxil wdg : X1, X2	Auxil wdg : Z1, Z2
50 Hz	70 V	5 V
60 Hz	85 V	6 V

# LSA 46.2 / 47.1 ALTERNATORS

## 5 - SPARE PARTS

### 5.1 - First maintenance parts

Emergency repair kits are available as an option. They contain the following items :

Ref.	Description	Qty	LSA 46.2	Part ref
	Emergency kit	1		
198	AVR	1	R 448	ESC 220 CV019
343	Diode bridge assembly	1	LSA 471. 9. 07 LSA 471.9 / 0.08	ADE 461 EQ 004
347	Surge suppressor	1	LSA 461.9.01	CII 111 PM 005
	AVR fuse	2	250 V - 10 A	PEL 010 FG 008
	Other spare parts			
60	DE bearing	1	6316 2RS/C3	RLT 080 TS030
70	NDE bearing	1	6315 2RS/C3	RLT 075 TS030

Ref.	Description	Qty	LSA 47.1	Part ref
	Emergency kit	1		
198	AVR	1	R 448	ESC 220 CV019
343	Diode bridge assembly	1	LSA 471. 9. 07 LSA 471,90.08	ADE 471 EQ 007
347	Surge suppressor	1	LSA 461.9.01	CII 111 PM 005
	AVR fuse	2	250 V - 10 A	PEL 010 FG 008
	Other spare parts			
60	DE bearing	1	6318 2RS/C3	RLT 090 TS030
70	NDE bearing	1	6315 2RS/C3	RLT 075 TS030

### 5.2 - Technical support service

Our technical support service will be pleased to provide any additional information you may require.

When ordering spare parts, you should indicate the complete machine type, its serial number and the information given on the nameplate.

Address your enquiry to your usual contact.

Part numbers should be identified from the exploded views and their description from the parts list.

Our extensive network of service centres can dispatch the necessary parts without delay.

To ensure correct operation and the safety of our machines, we recommend the use of original manufacturer spare parts. In the event of failure to comply with this advice, the manufacturer cannot be held responsible for any damage.

### 5.3 - Accessories

#### 5.3.1 - Space heater for use when stopped

The space heater must start up as soon as the alternator stops. It is installed at the rear of the machine. Its standard power is 250W with 220V or 250W with 110V on request.



**Warning : the power supply is present when the machine has stopped.**

#### 5.3.2 - Stator thermistor temperature probes (PTC)

These are thermistor triplets with a positive temperature coefficient installed in the stator winding (1 per phase). There can be a maximum of 2 triplets in the windings (at 2 levels : warning and trip) and 1 or 2 thermistors in the shields.

These probes must be linked to appropriate detection relays (supplied optionally)

Cold resistance of thermistor probes:  
100 to 250 Ω per probe.

#### 5.3.3 - Connection accessories

##### - 6-wire machines

Requirements for coupling (F) :

- 3 flexible shunts

##### - 12-wire machines

Requirements for coupling (A) :

- 6 links
- 1 link for the neutral

Requirements for coupling (F.F) :

- 4 flexible shunts
- 2 flexible shunts
- 1 link for the central point
- 1 additional starting range
- 1 additional terminal

Requirements for coupling (F) :

- 3 flexible shunts
- 1 link for the central point

# LSA 46.2 / 47.1 ALTERNATORS SPARE PARTS

## 5.4 - Exploded view, parts list

### 5.4.1 - Single bearing

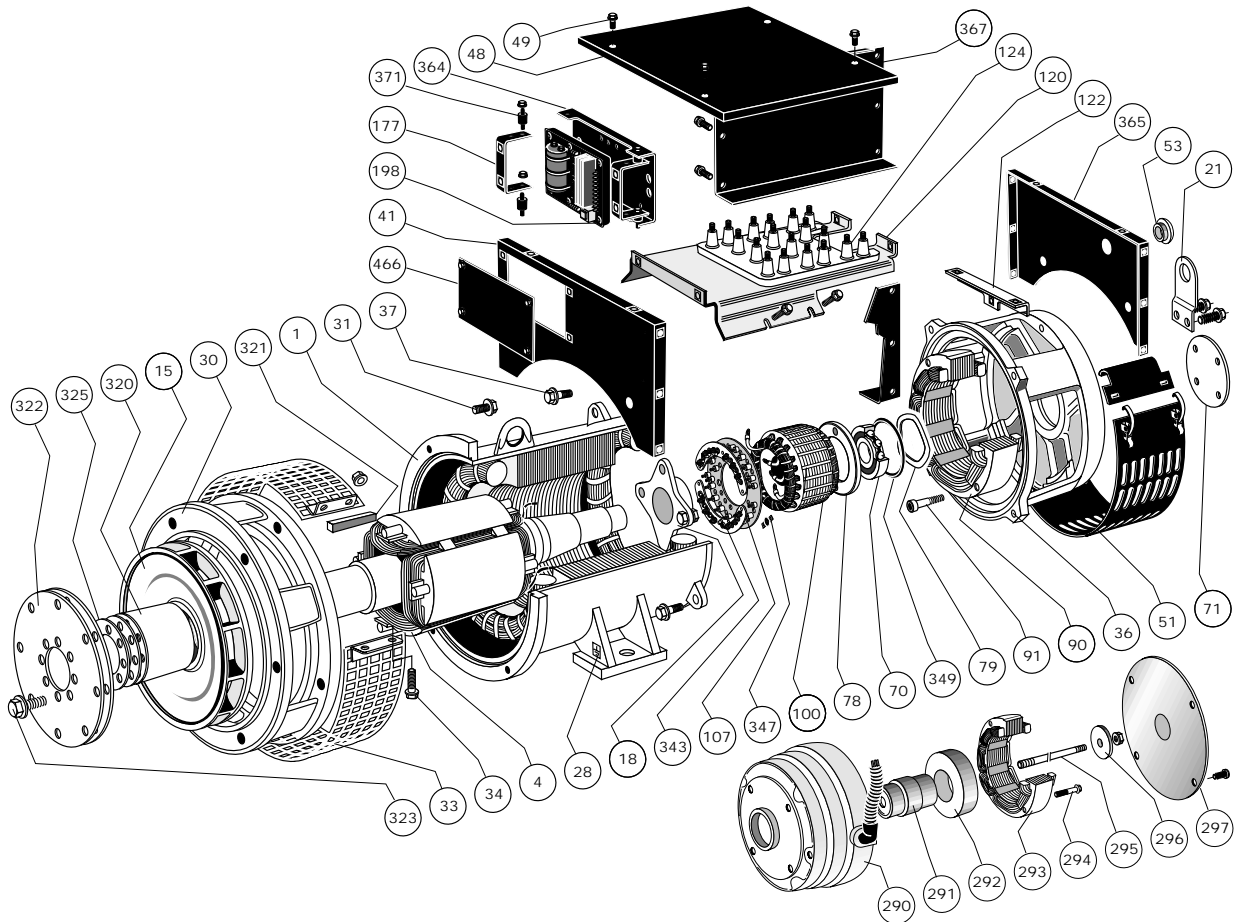

Ref.	Qty	Description	Ref.	Qty	Description
1	1	Stator assembly	124	1	Terminal block with terminals
4	1	Rotor assembly	177	2	AVR support bracket
15	1	Turbine	198	1	Voltage regulator (AVR)
18	1	Balancing disc	290	1	PMG housing
21	1	Lifting ring	291	1	Adaptation shaft
28	1	Earth terminal	292	1	Magnetic rotor
30	1	DE shield	293	1	Stator
31	6 or 4	Fixing screw	294	2	Fixing screw
33	1	Fan guard	295	1	Tie rod
34	2	Fixing screw	296	1	Cable gland washer + nut
36	1	Exciter end shield	297	1	End plate
37	4	Fixing screw	320	1	Coupling sleeve
41	1	Cover front panel	321	1	Sleeve key
48	1	Cover top panel	322	3	Coupling disc
49	-	Cover screws	323	6	Fixing screw
51	1	Air intake louvre	325	-	Spacer shim
53	1	Plug	343	1	Diode bridge assembly
70	1	NDE bearing	347	1	Protection varistor (+ PCB)
71	1	Outer bearing retainer	349	1	"O" ring
78	1	Inner bearing retainer	364	1	AVR support
79	1	Preloading wavy washer	365	1	Cover rear panel
90	1	Exciter field	367	2	Side panel
91	4	Fixing screw	371	4	Damper
100	1	Exciter armature	416	1	Filter
107	1	Crescent support	417	1	Filter support
120	1	Terminal support	466	2	AVR inspection door
122	1	Console support			

# LSA 46.2 / 47.1

## ALTERNATORS

### SPARE PARTS

#### 5.4.2 - Two-bearing

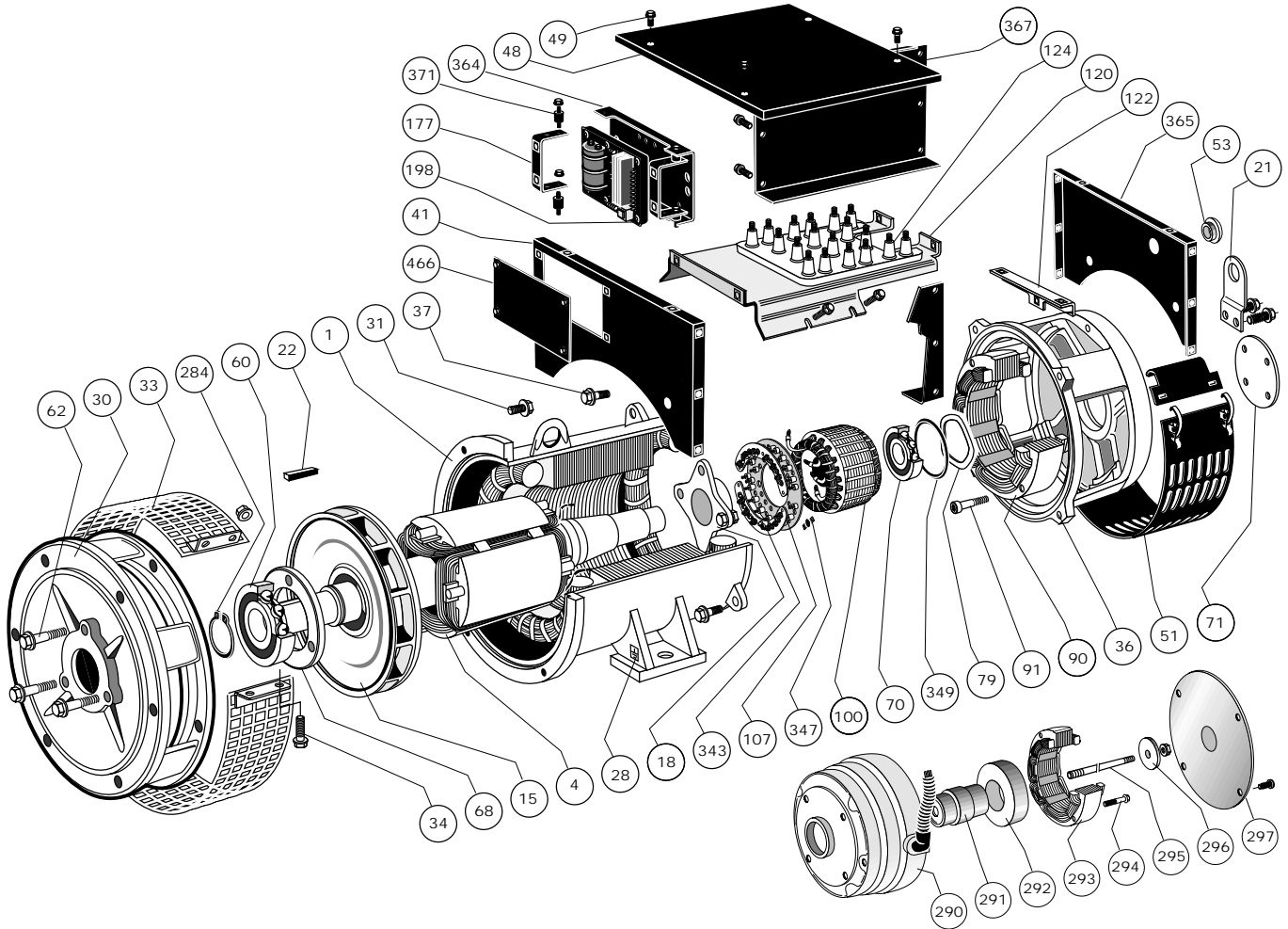

Ref.	Qty	Description	Ref.	Qty	Description
1	1	Stator assembly	100	1	Exciter armature
4	1	Rotor assembly	107	1	Crescent support
15	1	Turbine	120	1	Terminal support
18	1	Balancing disc	122	1	Console support
21	1	Lifting ring	124	1	Terminal block with terminals
22	1	Shaft extension key	177	2	AVR support bracket
28	1	Earth terminal	198	1	Voltage regulator (AVR)
30	1	DE shield	284	1	Circlips
31	6 or 4	Fixing screw	290	1	PMG housing
33	1	Fan guard	291	1	Adaptation shaft
34	2	Fixing screw	292	1	Magnetic rotor
36	1	Exciter end shield	293	1	Stator
37	4	Fixing screw	294	2	Fixing screw
41	1	Cover front panel	295	1	Tie rod
48	1	Cover top panel	296	1	Cable gland washer + nut
49	-	Cover screws	297	1	End plate
51	1	Air intake louvre	343	1	Direct diode crescent
53	1	Plug	347	1	Protection varistor (+ PCB)
60	1	DE bearing	349	1	"O" ring
62	3 or 4	Fixing screw	364	1	AVR support
68	1	Inner bearing retainer	365	1	Cover rear panel
70	1	NDE bearing	367	2	Side panel
71	1	Outer bearing retainer	371	4	Damper
79	1	Preloading wavy washer	416	1	Filter
90	1	Exciter field	417	1	Filter support
91	4	Fixing screw	466	2	AVR inspection door

**LSA 46.2 / 47.1**  
**ALTERNATORS**  
SPARE PARTS

**LSA 46.2 / 47.1**  
**ALTERNATORS**  
SPARE PARTS



**MOTEURS LEROY-SOMER 16015 ANGOULÊME CEDEX - FRANCE**