

Indian Maritime University				
(A Central University, Govt of India)				
End Semester Examination – June 2024				
Program Name : B Tech (ME)				
Semester : IV				
Subject Code : UG11T3403				
Subject Name : MECHANICS OF MACHINES II				
Date : 04.06.2024		Max Marks : 70		
Duration : 03 Hrs		Pass Marks : 35		
Part A (Part A is Compulsory)				
Q1 [10 x 1 = 10 Marks] Multiple Choice Questions	Options			
(1) Consider the following statement : The unbalanced force in a single-cylinder reciprocating engine is 1. Equal to inertia force of the reciprocating masses 2. Equal to gas force 3. Always fully balanced Which of the statement is/are correct?	A) 1 alone	B) 2 alone	C) 1 and 3	D) 2 and 3
(2) Whirling speed of shaft is the speed at which	A) shaft tends to vibrate in longitudinal direction	B) torsional vibrations occur	C) Shaft tends to vibrate vigorously in transverse direction	D) combination of transverse and longitudinal vibration occurs
(3) In a system subjected to damped forced vibrations, the ratio of maximum displacement to the static deflection is known as	A) Critical damping ratio	B) Damping factor	C) Logarithmic decrement	D) Magnification factor
(4) In balancing of 4-stroke in-line engines, firing order helps to control the magnitude of	A) Primary forces only	B) Secondary forces only	C) Primary forces and primary couples only	D) Primary and secondary couples only
(5) A motion is aperiodic at what value of the damping factor?	(A) 1.0 or above	(B) 0.5	(C) 0.3	(D) 0.866

(6) During torsional vibration of a shaft, the node is characterized by the	A) maximum angular velocity	B) maximum angular displacement	C) maximum angular acceleration	D) zero angular displacement
(7) The critical speed of a rotating shaft depends upon	A) mass	B) stiffness	C) mass and stiffness	D) mass, stiffness and eccentricity.
(8) A mass is suspended at the bottom of two springs in series having stiffness 10 N/mm and 5 N/mm. The equivalent spring stiffness of the two springs is nearly	A) 0.3 N/mm	B) 3.3 N/mm	C) 5 N/mm	D) 15 N/mm
(9) In a forced vibration with viscous damping, maximum amplitude occurs when forced frequency is	A) Equal to natural frequency	B) Slightly less than natural frequency	C) Slightly greater than natural frequency	D) Zero
(10) When the mass of a critically damped single degree of freedom system is deflected from its equilibrium position and released, it will	A) return to equilibrium position without oscillation	B) oscillate with increasing time period	C) oscillate with decreasing amplitude	D) oscillate with constant amplitude

Q2 [2 x 5 = 10 Marks] - Short Answer Type Questions

- (11) Brief outline of D'Alembert's method and Rayleigh's method to solve vibration problems.
- (12) Write a short note on free or natural and damped vibrations.
- (13) What is the phenomenon happens when shaft operated at whirling speed.
- (14) Explain logarithmic decrement
- (15) Define longitudinal, transverse and torsional vibrations

Part B (Answer any Five out of Seven) Each Question is for 10 Marks

16. A mass of 5 kg hangs from a spring and makes damped oscillations. If the time of 50 complete oscillations is found to be 20s, and the ratio of the first downward displacement to the sixth is found to be 22.5, find the stiffness of spring and the damping coefficient.
17. The flywheel of an engine dynamo weighs 150 N and has a radius of gyration of 0.25 m. The shaft at the flywheel end has an effective length of 0.2 m and is 50 mm in diameter. The armature weighs 80 N and has a radius of gyration of 0.2 m. The dynamo shaft has a diameter of 40 mm and an effective length of 0.15 m. Neglecting the inertia of the shaft and the coupling, calculate the frequency of torsional vibrations and position of node.
18. A shaft of 40 mm diameter and 2.5 m length has a mass of 15 kg per metre length. It is simply supported at the ends and carries three masses of 90 kg, 140 kg and 60 kg at 0.8m, 1.5m and 2m respectively from the left support. Taking $E = 200 \text{ GN/m}^2$. Find the frequency of the transverse vibration.
19. A centrifugal fan of mass 5 kg has a rotating unbalance of 0.25kgm. When dampers having damping factor 0.2 are used, specify the springs for mounting such

that only 10% of the unbalance force is transmitted to the floor and the force transmitted. The fan is running at a constant speed of 1000 rpm.

20. A shaft carries four masses as shown in fig 20 (a) and (b). The balancing masses are to be placed in planes L and M. If the balancing masses revolve at a radius of 100 mm, find their magnitude and angular position.

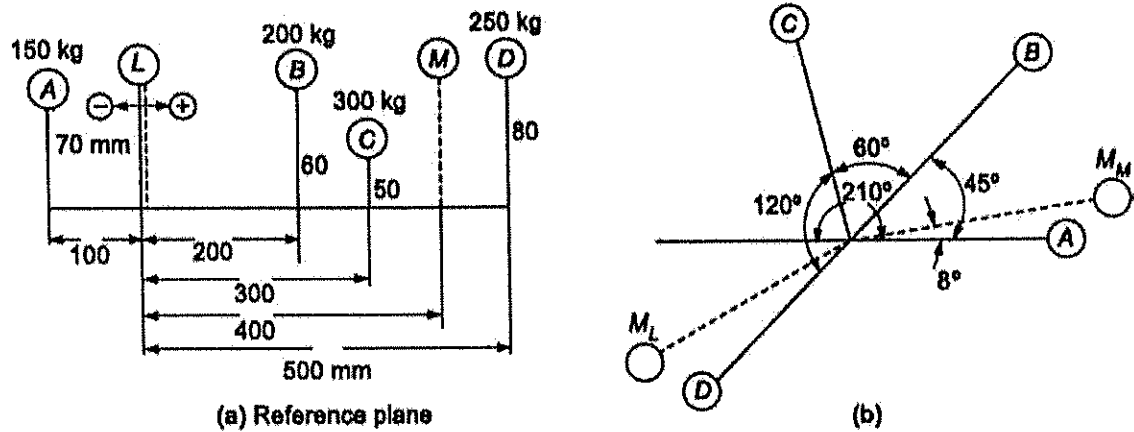

Figure 20

21. A rotor has a mass of 12 kg and is mounted midway on a 24 mm diameter horizontal shaft supported at the ends by two bearings. The bearings are 1 m apart. The shaft rotates at 2400 rpm. If the centre of mass of the rotor is 0.11 mm away from the geometric centre of the rotor due of a certain manufacturing defect, find the amplitude of the steady-state vibration and the total force transmitted to each bearing. $E = 200 \text{ GN/m}^2$.

22. Find the natural frequency of the oscillation of the vibrating system as shown in fig.22 (a) and (b).

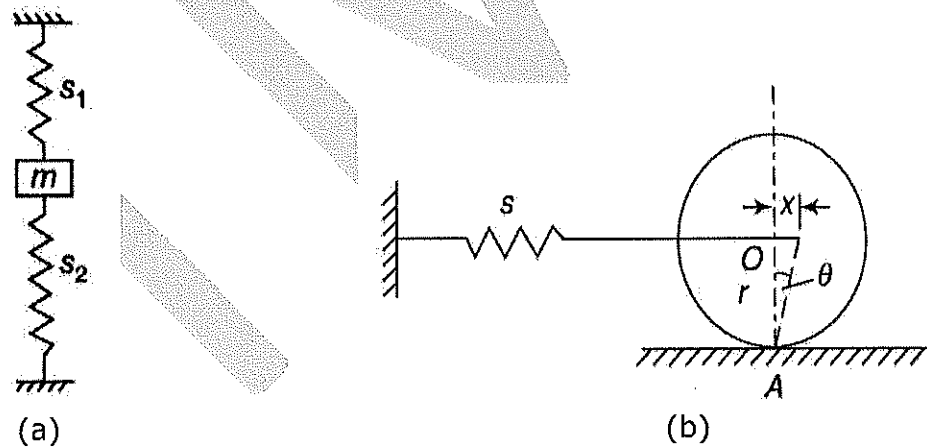

Figure 22

