

INDIAN MARITIME UNIVERSITY

(A Central University, Government of India)

END SEMESTER EXAMINATION December 2017

Programme: B Tech (Marine Engineering)

Semester: IV

Subject Name: MECHANICS OF MACHINES-II

Subject Code:

UG11T2403/ UG11T1403

Date: 29.12.2017

Maximum Marks: 100

Time: 3 Hrs

Pass Marks: 50

PART – A

Marks: 10 X 3=30

(All questions are compulsory)

Q.1 (a) A body is subjected simultaneously by two harmonic motions. They are $x_1 = 15 \sin(\omega t + \pi/6)$; $x_2 = 8 \cos(\omega t + \pi/3)$. Determine the amplitude and phase angle of resultant harmonic motion.

(b) What do you understand by "Engine Rocking" and how do you minimize the same.

(c) Explain how complete secondary balance of multi-cylinder-engine is carried out.

(d) A four wheeler having a mass 4500 kg deflects its spring 9 cm under its load when at rest. Determine the natural frequency of the four wheeler in vertical direction.

(e) A connecting rod is supported at the wrist pin end. It is displaced and allowed to oscillate like a compound pendulum. Mass of the connecting rod is 5 kg and CG is 20 cm from pivot point. If the frequency of oscillations is 40 cycles/minute, then determine the moment of inertia of the system about CG.

(f) Spring mass system having spring stiffness 'K' N/m and mass of 'M' kg has its natural frequency of vibration 3.56 Hz. on adding 5 kg mass, frequency reduced to 2.9 Hz. Then find the spring stiffness.

(g) In all wall clocks which work on the principle of simple pendulum, evaluate the length of string in mt that can be worked out for a time period of 1 sec.

(h) A 16 kg body is suspended from a spring of constant 'K'. $K = 1200$ N/m. Mass of the spring is 2.7 kg. Find the Natural frequency of the above system considering the mass of the system in Hz.

(i) In a damped vibrating system the mass being 6 kg makes 25 oscillations in 11 seconds. The amplitude of the vibrations decreases by 30 % of its initial value after 5 cycles. Determine the Damping ratio.

(j) A body performs two vibratory motions simultaneously.

$X_1 = 1.93 \sin 9.5 t$; $X_2 = 2.00 \sin 10.0 t$, units of amplitude and circular frequency and time are in cm., rad/sec and sec respectively. Determine the maximum beat amplitude and the beat frequency in Hz

PART – B (5 X 14=70 Marks)

(Answer any 5 of the following)

Q.2 An engine having five cylinders in line, works on a four stroke cycle. The distance between centre lines is 150 mm and the reciprocating mass for each cylinder is 1.5 kg, the engine stroke length is 100 mm and the connecting rod length is 175 mm. The engine runs at 600 rpm. Examine the engine for balance of primary and secondary couples. Determine the maximum values of these and the position of the central crank at which these maximum values occur. Firing order 1-4-5-3-2-1.

Q.3 An engine drives a centrifugal compressor through the gears. The gear is coupled to engine and Pinion is coupled to impeller. The length and the diameter of the shaft from engine to the gear are 1 m and 80 mm respectively. The centrifugal compressor runs 3 times faster than that of engine. The length and the diameter of the shaft from pinion to the impeller are 400 mm and 60 mm respectively. The moment of inertias of pinion and gear are 1 kg-m² and 11 kg-m² respectively. The moment of inertias of engine and pump impeller are 100 kg-m² and 25 kg-m² respectively. (Given modulus of rigidity for shaft material is 80 GN / m².) Determine natural frequencies and node points considering the inertias of the gears.

Q.4 For the system shown in Fig.1 determine natural frequency and the position of node. Assume $G=80 \times 10^9 \text{ N/m}^2$

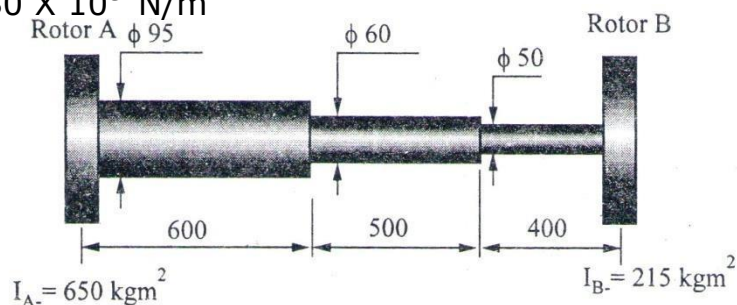

Fig. 1

Q.5 A shaft of 50 mm diameter and 3 m length has a mass of 10 kg per meter length as shown in Fig. 2. It is simply supported at the ends and carries three masses of 70 kg, 90 kg, 50 kg at the distances of 1 m, 2 m, 2.5 m from Left end support as shown in fig.1. Find the lowest natural frequency of transverse vibrations by Dunkerley's method. Assume $E=200 \times 10^9 \text{ N/m}^2$

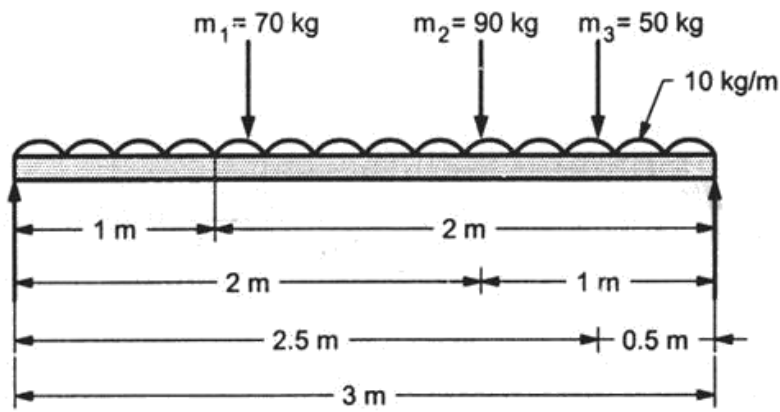

Fig. 2

Q.6 An engine weighing 1 kN is supported on four springs. It has a stroke length of 80 mm and runs at 1000 rpm. If the springs are symmetrically placed with respect to CG of the engine, find neglecting the damping the combined stiffness of the springs in order that the force transmitted to the foundation is 1/25 times of the impressed force. It is found that the damping however small reduces the amplitude of successive vibrations by 25%.

i) Force transmitted to the foundation at 1000 rpm ii) Force transmitted to the foundation at resonance and iii) the amplitude of vibration if the weight of the reciprocating parts is 20 N

Q.7 A disc of a torsional pendulum has a moment of inertia of 600 kg-cm^2 and is immersed in a viscous fluid. The brass shaft attached to it is of 10 cm diameter and 40 cm long. When the pendulum is vibrating, the observed amplitudes on the same side of the rest position for successive cycles are 9 deg. ,6 deg. and 4 deg..Determine i) logarithmic decrement ii) damping torque at unit velocity iii) the periodic time of vibrations. Assuming for the brass shaft, $G=4.4 \times 10^{10} \text{ N /m}^2$. What would be the frequency, if the disc is removed from the viscous fluid.

Q.8 A refrigerator unit of mass 35 kg is to be supported by three springs of stiffness $k \text{ N/m}$ each. If the unit operates at 600 rpm, what should be value of spring constant, k if only 10% of the shaking force of the unit is to be transmitted to the supporting structure neglecting damping?
