

Operating Instructions



Diesel Engine

D 2866 E

D 2866 TE

D 2866 LE

D 2866 LXE



Dear Customer

These Operating Instructions are intended to familiarize you with your new MAN Diesel engine and how it operates.

This manual is supplemented by the publication “Fuels, Lubricants and Coolants for MAN Diesel Engines” and the “Service record”.

Note:

All three publications belong to the engine and must always be kept ready to hand near the engine in the engine room.

Please read this Manual and the “Instructions for the installation of MAN Diesel Engines” before you put the new engine into operation.

Comply in full with instructions relating to operation, prevention of accidents and environmental protection.

MAN Diesel engines are developed and manufactured in line with the latest state of the art. However, trouble-free operation and high performance can only be achieved if the specified maintenance intervals are observed and only approved fuels, lubricants and coolants are used.

It is imperative and in your own interest to entrust your MAN Local Service Centre with the removal of any disturbances and with the performance of checking, setting, and repair work.

Yours faithfully,
MAN Nutzfahrzeuge Aktiengesellschaft
Werk Nürnberg

Subject to change to keep abreast with technological progress.

© 2001 MAN Nutzfahrzeuge Aktiengesellschaft
No parts of this publication may be reproduced or translated without prior written permission of MAN. MAN explicitly reserves all rights according to copyright law.

Declaration	3
Nameplates	4
Safety regulations	5
Technical information	10
Engine views	10
Engines	16
Engine lubrication	18
Fuel system	20
Turbocharger	21
Intercooler	22
Cooling	22
Air cleaner	22
Electrical equipment	23
Commissioning and operation	24
Preparations	24
Starting	25
Running in	25
During operation	25
Shutting down	26
Temporary decommissioning of engines	26
Maintenance and care	27
Engine lubrication	27
Fuel system	29
Cooling	35
Turbocharger	39
Intercooler	40
Air cleaner	41
Checking and setting	44
To check and set the start of delivery	44
To check and adjust valve clearance	48
Cylinder head bolts	48
V-belts	51
Technical data	54
Index	60

Declaration

In accordance with Article 4, paragraph 2, in conjunction with Appendix II, section B, of Directive 89/392/EEC, version 93/44/EEC

MAN Nutzfahrzeuge Aktiengesellschaft,

hereby declares that the engine described below is destined for installation in a machine as defined in the EC directive on machines.

Engine model:

Design:

For data see original declaration

Engine number:

If required this declaration is enclosed with the delivery note.

Rating / speed:

Note:

The manufacturer of the complete ready-to-use machine in which this engine is to be installed must take the further action necessary in the context of indirect safety-related engineering and provision of instructions to ensure that the ready-to-use machine complies with the requirements of the EC directive on machines.

The engine must not be put into operation until the complete machine satisfies the conditions laid down in the EC directive on machines 89/392/EEC, most recently amended by 93/44/EEC, or the latest amendment of said directive.

MAN Nutzfahrzeuge Aktiengesellschaft

Vogelweiherstraße 33

D-90441 Nürnberg



Nameplates

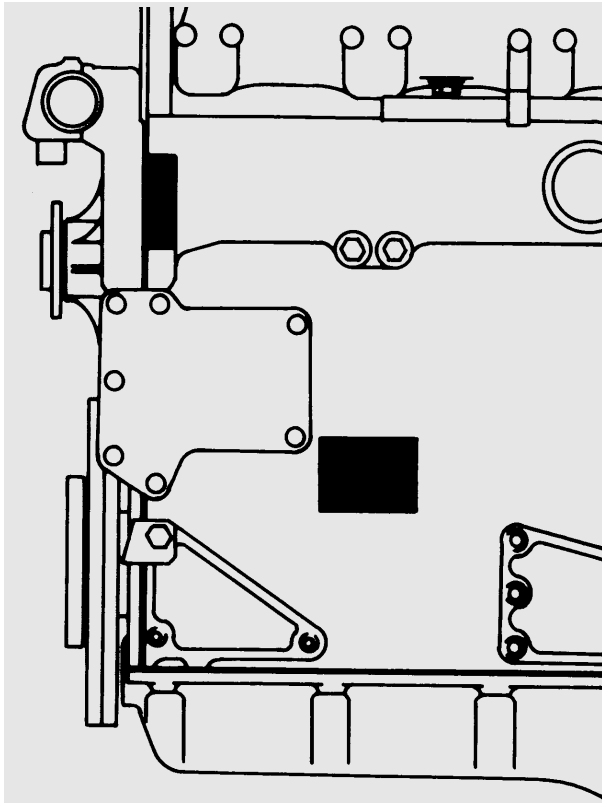

Model

.....

delivered on

.....

installed on

.....

In all your correspondence please always quote engine model, serial number and job number (Order number).

MAN Nutzfahrzeuge Aktiengesellschaft
 Typ
 Motor-Nr. / Engine No. NI/II

Enter 14-digit serial number (is used in the spare parts catalog to distinguish between spare parts).

MAN Nutzfahrzeuge Aktiengesellschaft
 Werk Nürnberg Germany
DIESEL ENGINE

Bauj. Year	Typ	Model	Motor-Nr.	Serial No
<input type="text"/>	<input type="text"/>	<input type="text"/>	<input type="text"/>	<input type="text"/>
Werk-Nr.	Job No	Leistung kW Rating kW	Drehz. 1/min	Speed rpm
<input type="text"/>	<input type="text"/>	<input type="text"/>	<input type="text"/>	<input type="text"/>
Temp.°C	Leistg. PS Rating BHP	Aufstellhöhe m uNN Altitude m		
<input type="text"/>	<input type="text"/>	<input type="text"/>		

-0219

Enter 14-digit engine serial number.

Enter 6-digit job number (Order number).

General notes

Handling diesel engines and the necessary resources is no problem when the personnel commissioned with operation and maintenance are trained accordingly and use their common sense.

This summary is a compilation of the most important regulations. These are broken down into main sections which contain the information necessary for preventing injury to persons, damage to property and pollution. In addition to these regulations those dictated by the type of engine and its site are to be observed also.

Important:

If, despite all precautions, an accident occurs, in particular through contact with caustic acids, fuel penetrating the skin, scalding from hot oil, anti-freeze being splashed in the eyes etc., ***consult a doctor immediately.***

Regulations designed to prevent accidents with injury to persons

During commissioning, starting and operation

- Before putting the engine into operation for the first time, read the operating instructions carefully and familiarize yourself with the “critical” points. If you are unsure, ask your MAN representative.
- For reasons of safety we recommend you attach a notice to the door of the engine room prohibiting the access of unauthorized persons and that you draw the attention of the operating personal to the fact that they are responsible for the safety of persons who enter the engine room.
- The engine must be started and operated only by authorized personnel. Ensure that the engine cannot be started by unauthorized persons.
- When the engine is running, do not get too close to the rotating parts. Wear close-fitting clothing.
- Do not touch the engine with bare hands when it is warm from operation – risk of burns.
- Exhaust gases are toxic. Comply with the instructions for the installation of MAN Diesel engines which are to be operated in enclosed spaces. Ensure that there is adequate ventilation and air extraction.
- Keep vicinity of engine, ladders and stairways free of oil and grease. Accidents caused by slipping can have serious consequences.

During maintenance and care

- Always carry out maintenance work when the engine is switched off. If the engine has to be maintained while it is running, e.g. changing the elements of change-over filters, remember that there is a risk of scalding. Do not get too close to rotating parts.
- Change the oil when the engines is warm from operation.
Caution:
There is a risk of burns and scalding. Do not touch oil drain plugs or oil filters with bare hands.
- Take into account the amount of oil in the sump. Use a vessel of sufficient size to ensure that the oil will not overflow.
- Open the coolant circuit only when the engine has cooled down. If opening while the engine is still warm is unavoidable, comply with the instructions in the chapter entitled "Maintenance and Care".
- Neither tighten up nor open pipes and hoses (lube oil circuit, coolant circuit and any additional hydraulic oil circuit) during the operation. The fluids which flow out can cause injury.
- Fuel is inflammable. Do not smoke or use naked lights in its vicinity. The tank must be filled only when the engine is switched off.
- When using compressed air, e.g. for cleaning the radiator, wear goggles.
- Keep service products (anti-freeze) only in containers which can not be confused with drinks containers.
- Comply with the manufacturer's instructions when handling batteries.
Caution:
Accumulator acid is toxic and caustic. Battery gases are explosive.

When carrying out checking, setting and repair work

- Checking, setting and repair work must be carried out by authorized personnel only.
- Use only tools which are in satisfactory condition. Worn open-end wrench slip, which could lead to injury.
- When the engine is hanging on a crane, no-one must be allowed to stand or pass under it. Keep lifting gear in good condition.
- When working on parts which contain asbestos, comply with the notes at the end of this chapter.

- When checking injectors do not put your hands under the jet of fuel. Do not inhale atomised fuel.
- When working on the electrical system disconnect the battery earth cable first. Connect it up again last in order to prevent short circuits.
- When welding comply with the “Instructions for welders”.

Regulations designed to prevent damage to engine and premature wear

Do not demand more from the engine than it is able to supply in its intended application. Detailed information on this can be found in the sales literature. The injection pump must not be adjusted without prior written permission of MAN Nürnberg.

If faults occur, find the cause immediately and have it eliminated in order to prevent more serious damage.

Use only genuine MAN spare parts. MAN will accept no responsibility for damage resulting from the installation of other parts which are supposedly “just as good”.

In addition to the above, note the following points:

- Never let the engine run when dry, i.e. without lube oil or coolant.
- When starting do not use any additional starting aids (e.g. injection with starting pilot).
- Use only MAN-approved service products (fuel, engine oil, anti-freeze and anti-corrosion agent). Pay attention to cleanliness. The Diesel fuel must be free of water. See “Maintenance and care”.
- Have the engine maintained at the specified intervals.
- Do not switch off the engine immediately when it is warm, but let it run without load for about 5 minutes so that temperature equalization can take place.
- Never put cold coolant into an overheated engine. See “Maintenance and care”.
- ***Do not add so much engine oil that the oil level rises above the max. marking on the dipstick. Do not exceed the maximum permissible tilt of the engine.*** Serious damage to the engine may result if these instructions are not adhered to.
- Always ensure that the testing and monitoring equipment (for battery charge, oil pressure, coolant temperature) function satisfactorily.

- Comply with instructions for operation of the alternator. See “Commissioning and operation”.
- Do not let the raw water pump run dry. If there is a risk of frost, drain the pump when the engine is switched off.

Regulations designed to prevent pollution
--

Engine oil and filter elements / cartridges, fuel/fuel filter

- Take old oil only to an old oil collection point.
- Take strict precautions to ensure that no oil or Diesel fuel gets into the drains or the ground.
The drinking water supply could be contaminated.
- Filter elements are classed as dangerous waste and must be treated as such.

Coolant

- Treat undiluted anti-corrosion agent and / or antifreeze as dangerous waste.
- When disposing of spent coolant comply with the regulations of the relevant local authorities.

Notes on safety in handling used engine oil *
--

Prolonged or repeated contact between the skin and any kind of engine oil decreases the skin. Drying, irritation or inflammation of the skin may therefore occur. Used engine oil also contains dangerous substances which have caused skin cancer in animal experiments. If the basic rules of hygiene and health and safety at work are observed, health risks are not to the expected as a result of handling used engine oil.

Health precautions:

- Avoid prolonged or repeated skin contact with used engine oil.
- Protect your skin by means of suitable agents (creams etc.) or wear protective gloves.
- Clean skin which has been in contact with engine oil.
 - Wash thoroughly with soap and water. A nailbrush is an effective aid.
 - Certain products make it easier to clean your hands.
 - Do not use petrol, Diesel fuel, gas oil, thinners or solvents as washing agents.

- After washing apply a fatty skin cream to the skin.
- Change oil-soaked clothing and shoes.
- Do not put oily rags into your pockets.

Ensure that used engine oil is disposed of properly – Engine oil can endanger the water supply –

For this reason do not let engine oil get into the ground, waterways, the drains or the sewers. Violations are punishable.

Collect and dispose of used engine oil carefully. For information on collection points please contact the seller, the supplier or the local authorities.

* Adapted from “Notes on handling used engine oil”.

Note on parts containing asbestos

- Certain parts of the engine (gaskets) may contain asbestos. Spare parts and, where necessary, their packaging is marked accordingly (see illustration below).
- When parts that contain asbestos are machined fine asbestos dust may be released. To prevent possible damage to health please take appropriate safety precautions and follow the advice given below:
- Wherever possible work in the open air or in well ventilated rooms.
- If possible use hand-operated or slow-running machines, if necessary with a dust trap. If fast-running machines are used they ought always to have such a device.
- Wet the material before cutting or drilling it.
- Wet the dust, put it into a tightly closing container and have it disposed of as dangerous waste.



Engine views D 2866 E

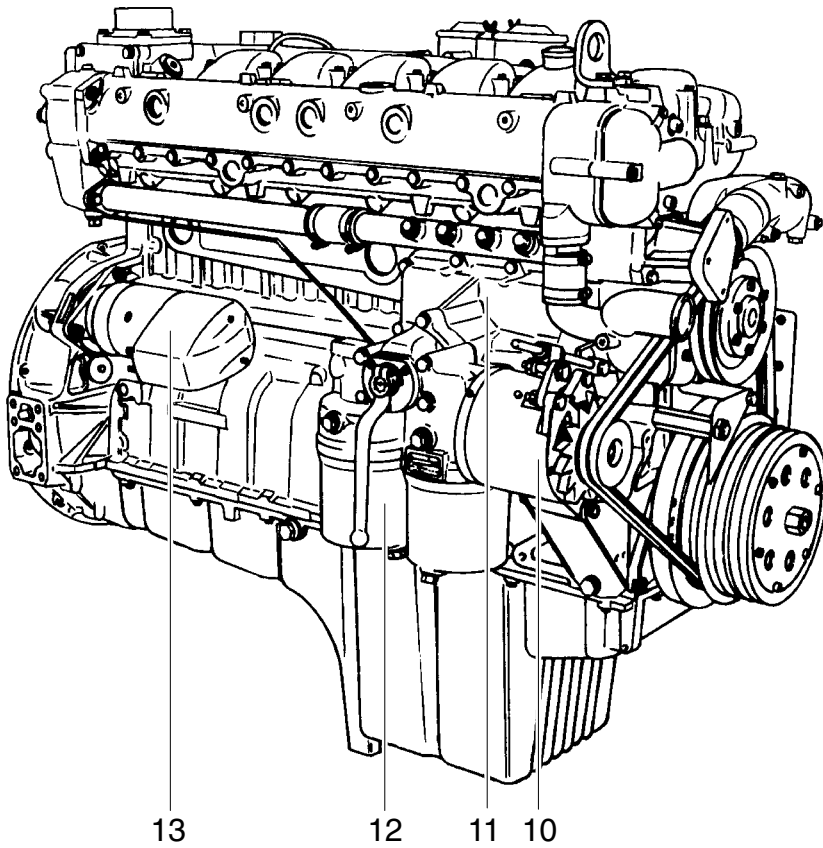
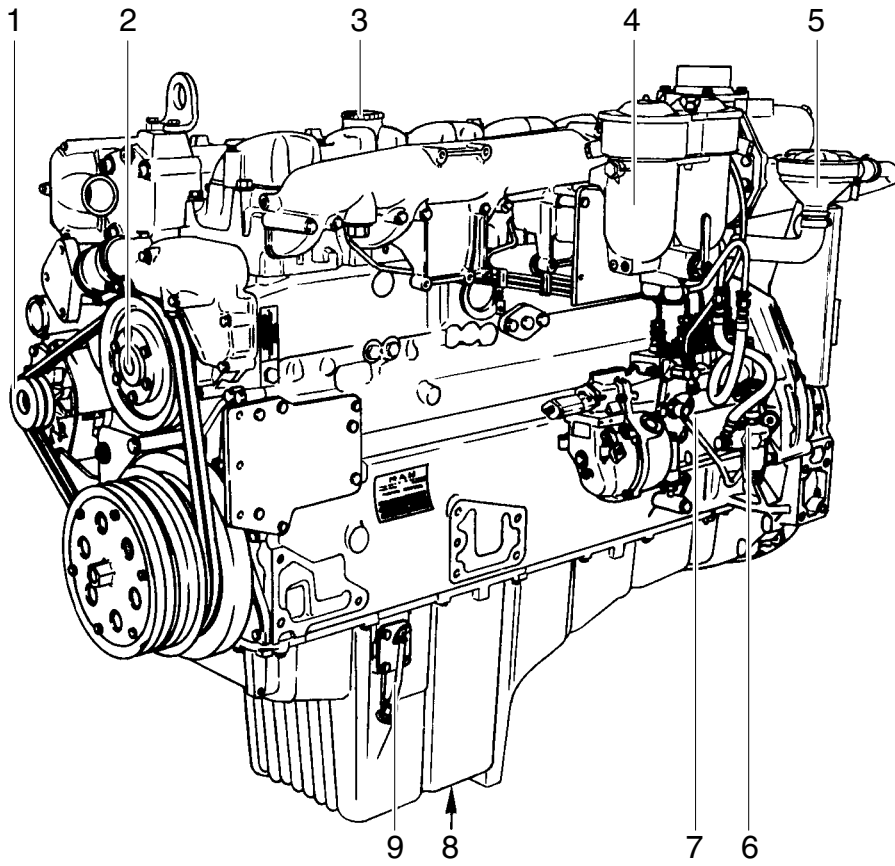

-
- 1 Tensioning pulley
 - 2 Water pump
 - 3 Oil filler neck
 - 4 Tandem fuel filter
 - 5 Oil separator valve for crankcase breather
 - 6 Fuel lift pump with prestrainer
 - 7 Injection pump
 - 8 Oil drain plug
 - 9 Oil dipstick
 - 10 Alternator
 - 11 Oil cooler
 - 12 Oil filter
 - 13 Starter motor

Engine views D 2866 TE

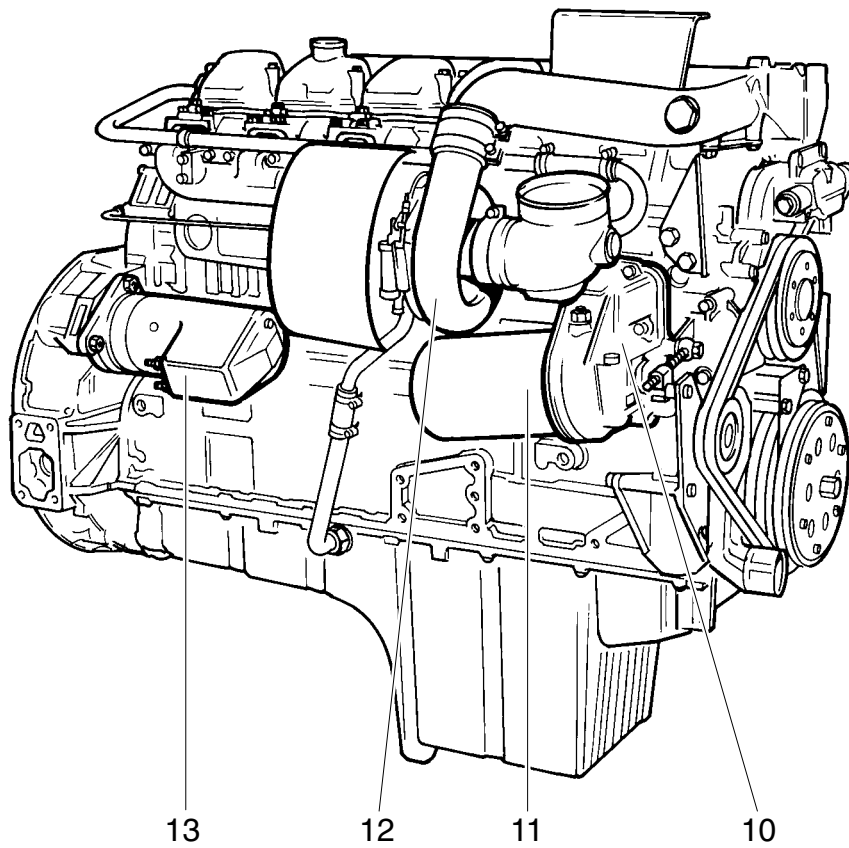
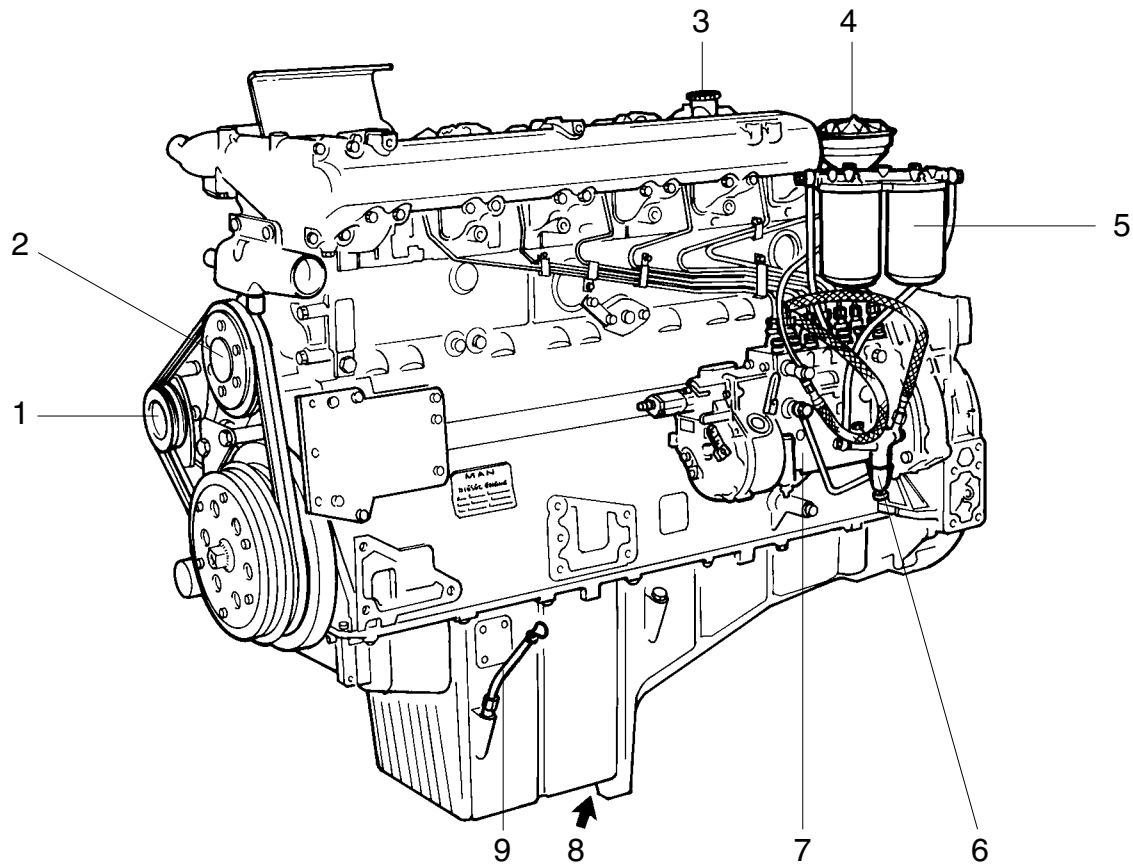

-
- 1 Tensioning pulley
 - 2 Water pump
 - 3 Oil filler neck
 - 4 Oil separator valve for crankcase breather
 - 5 Tandem fuel filter
 - 6 Fuel lift pump with prestrainer
 - 7 Injection pump
 - 8 Oil drain plug
 - 9 Oil dipstick
 - 10 Oil cooler
 - 11 Oil filter
 - 12 Turbocharger
 - 13 Starter motor

Engine views D 2866 LE, LXE

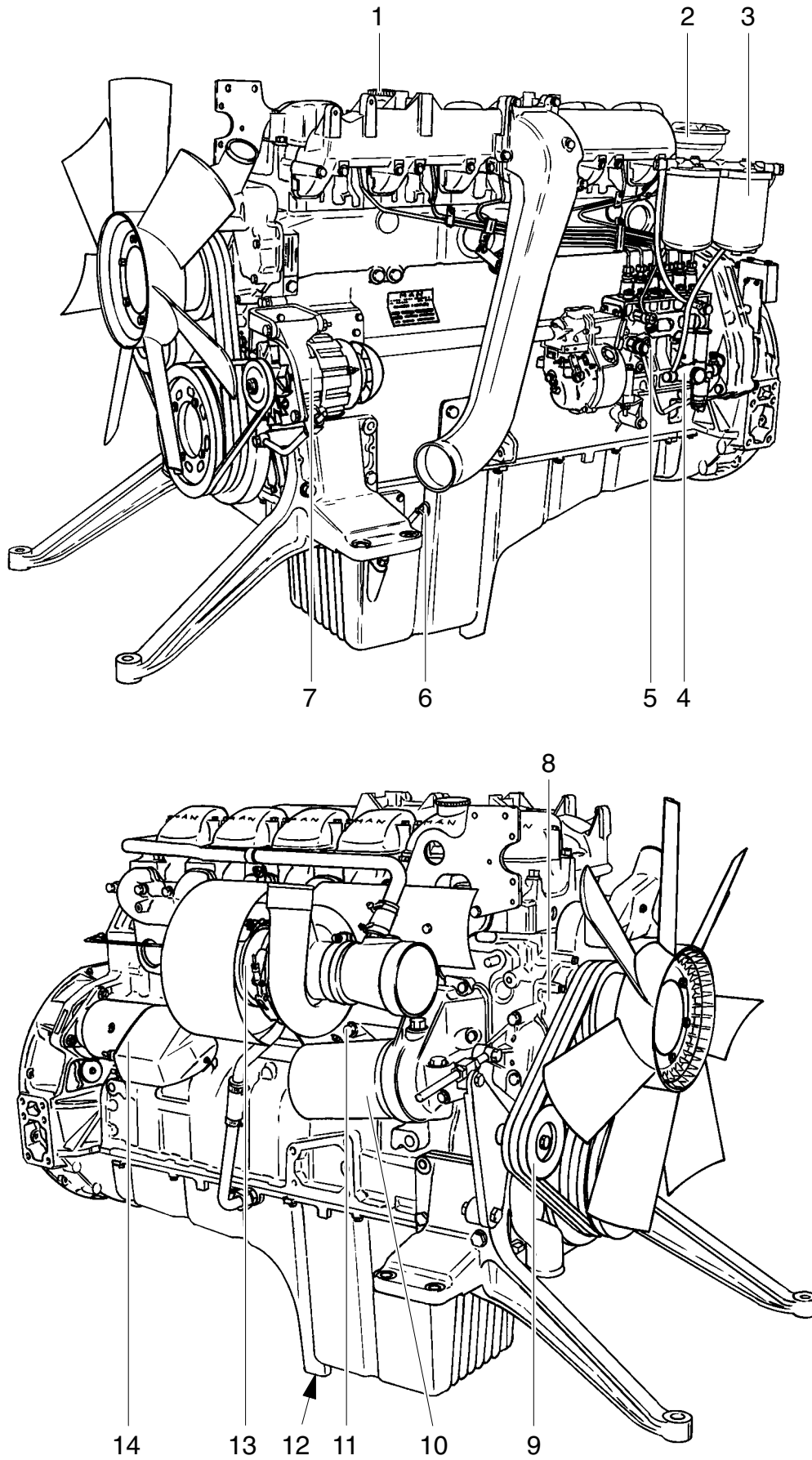

-
- 1 Oil filler neck
 - 2 Oil separator valve for crankcase breather
 - 3 Tandem fuel filter
 - 4 Fuel lift pump with prestrainer
 - 5 Injection pump
 - 6 Oil dipstick
 - 7 Alternator
 - 8 Water pump
 - 9 Tensioning pulley
 - 10 Oil filter
 - 11 Water drain plug
 - 12 Oil drain plug
 - 13 Turbocharger
 - 14 Starter motor

Engines

The engines D 2866 E / TE / LE / LXE are in-line vertical liquid-cooled 6-cylinder four-stroke Diesel engines with direct injection. D 2866 E is a naturally aspirated engine. D 2866 TE is turbocharged, and D 2866 LE / LXE are turbocharged and intercooled.

Engine block

The cylinder block is a single piece of alloy cast iron. To increase its stiffness, it is extended to a level below the crankshaft centre line. The engine has replaceable wet cylinder liners and individual cylinder heads with shrunk-in valve seat rings and replaceable valve guides.

Piston / Conrod / Crank assembly

The forged crankshaft has screwed-on counterweights. Radial seals with replaceable wearing rings on crankshaft and flywheel are provided to seal the crankcase penetrations.

The connecting rods are die-forged, diagonally split and can be removed through the top of the cylinders together with the pistons. Crankshaft and connecting rods run in steel-backed lead bronze ready-to-fit type bearings.

Engine timing

Camshaft, oil pump and injection pump are driven by a gear train arranged at the fly-wheel end.

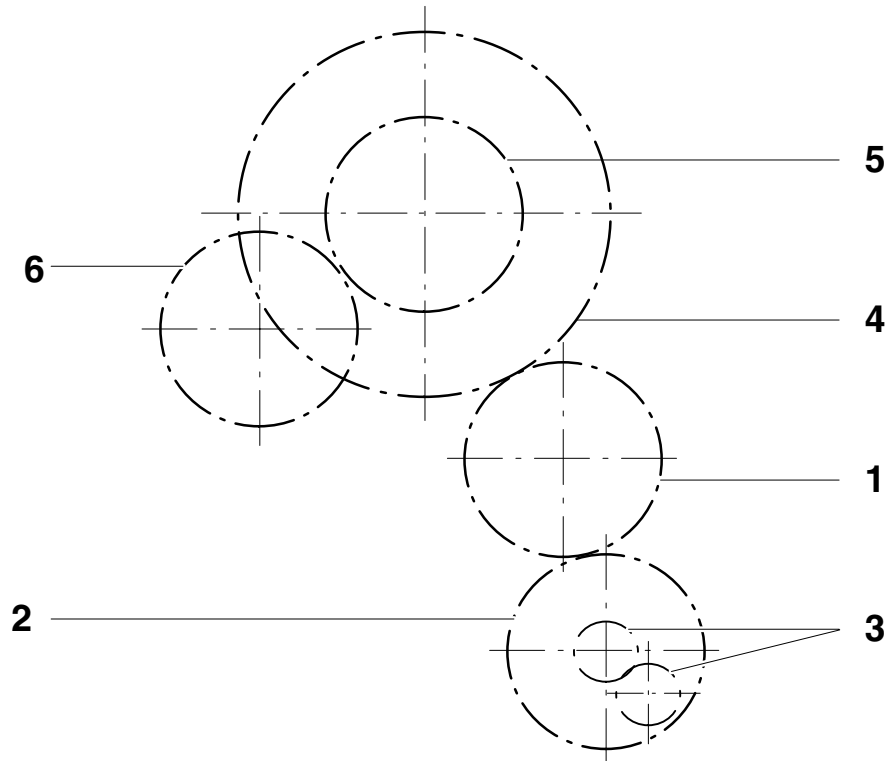

- | | |
|---------------------------|-----------------------------|
| 1 Crankshaft gear | 4 Camshaft drive gear |
| 2 Oil pump drive gear | 5 Idler gear |
| 3 Oil pump impeller gears | 6 Injection pump drive gear |

The crankshaft gear and camshaft gear are match-marked by “1” or “●”.

Valves

The overhead valves are actuated via chilled cast iron tappets, push rods and rocker arms from the camshaft.

Engine lubrication

The engine is equipped with force-feed lubrication.

The pressure is produced by a gear pump whose drive gear is in direct mesh with the crankshaft gear at the flywheel end.

The oil pump draws the oil from the oil sump and delivers it through the oil cooler and oil filter to the main distributor gallery and from there to the main bearings, big-end bearings and camshaft bearings as well as to the small-end bearings and the rocker arms.

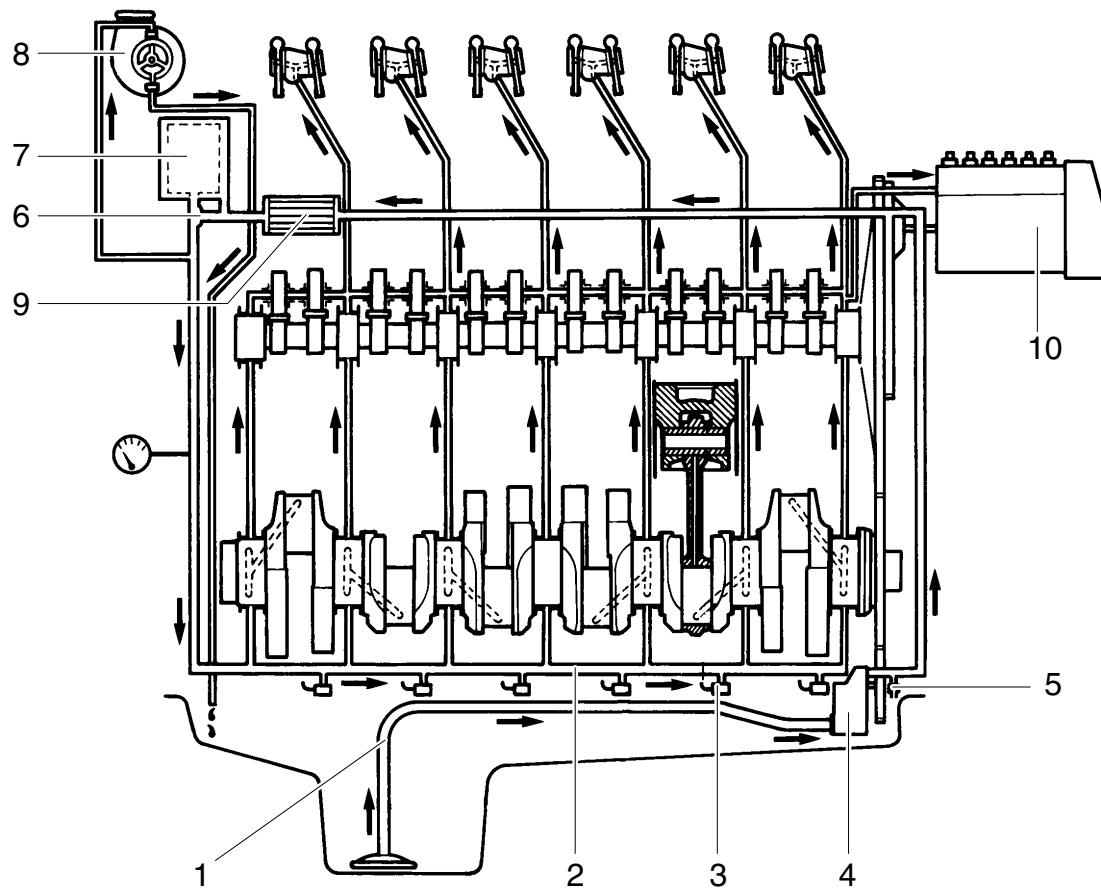

- | | |
|---|---|
| 1 Oil suction pipe | 7 Oil filter |
| 2 Main oil galleries | 8 Turbocharger
(D 2866 TE / LE / LXE only) |
| 3 Jets for piston cooling and cam lubrication | 9 Oil cooler |
| 4 Oil pump | 10 Injection pump |
| 5 Oil relief valve | |
| 6 Bypass valve | |

The injection pump and the turbocharger are also connected to the engine lubricating system.

The cylinder walls and timing gears are splash-lubricated.

Each cylinder has an oil jet provided for cooling the underside of the pistons.

The lube oil is cleaned in a full-flow oil filter.

Depending on the agreed extent of delivery and the design of the engine, the lube oil circuit can be equipped with oil pressure monitors (advance warning and cut-off function) which shut the engine down in the event of a sudden loss of pressure.

Oil cooler

An oil cooler is provided between the oil filter and the crankcase. This cooler is of the flat tube type with turbulence inserts and operated by the coolant.

Fuel system

The fuel is delivered by the fuel lift pump via the fuel filter to the injection pump and from there to the injectors.

The fuel is sprayed into the cylinder through four-hole nozzles fitted in screw-fit injectors in the cylinder heads.

Excessive fuel delivered and leak fuel from the injectors flow through the return pipe back to the tank. A strainer and a hand pump are arranged ahead of the fuel lift pump.

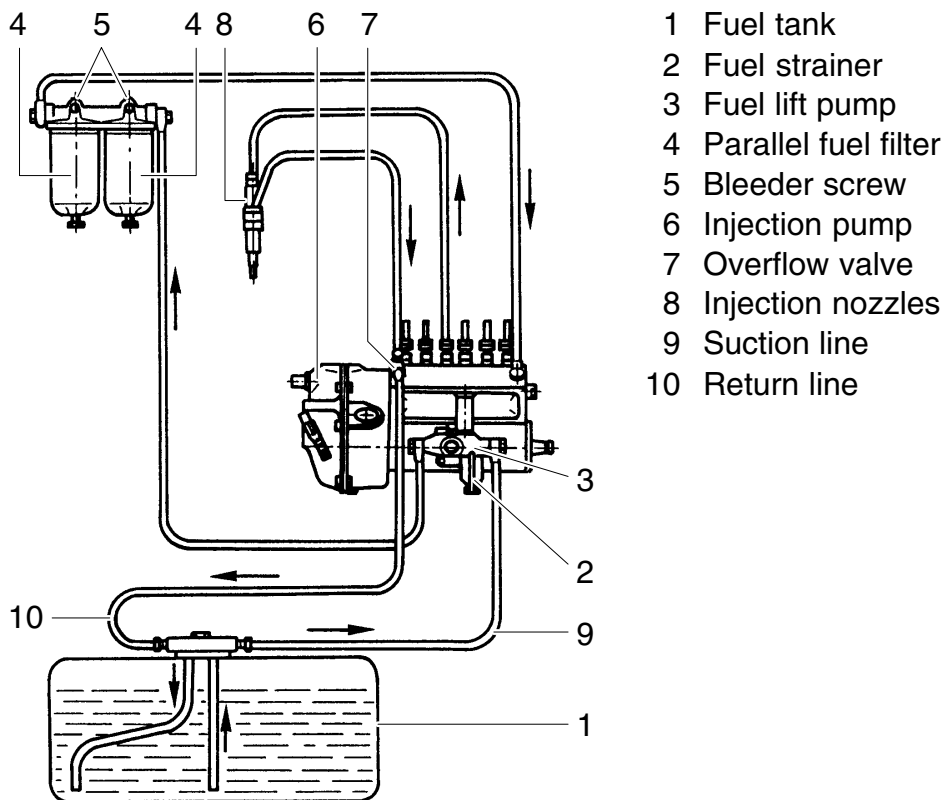

- 1 Fuel tank
- 2 Fuel strainer
- 3 Fuel lift pump
- 4 Parallel fuel filter
- 5 Bleeder screw
- 6 Injection pump
- 7 Overflow valve
- 8 Injection nozzles
- 9 Suction line
- 10 Return line

Injection pump

The in-line injection pump is driven via gears from the crankshaft. It is connected to the force-feed lubricating system of the engine and consequently maintenance-free.

The centrifugal governor flange-mounted on the pump casing is a variable range governor designed to keep the speed set by the control lever constant under conditions of varying load.

The governor of the turbocharged engines has a full load stop controlled by the charge-air pressure and is designed to decrease the full load fuel quantity in the low speed range from a certain (adjustable) charge-air pressure onwards.

Fuel filters

Before entering the suction chamber of the injection pump, the fuel is cleaned in a two-stage, parallel or changeover filter.

Turbocharger (D 2866 TE, LE, LXE)

The exhaust gases of the engine are passed through the turbine rotor of the turbocharger. Air impeller mounted on the same shaft draws in fresh air and delivers it at a higher pressure to the cylinders.

The turbocharger is air-cooled or liquid-cooled. Lubrication of the main bearing is by oil under pressure from the engine lubricating system.

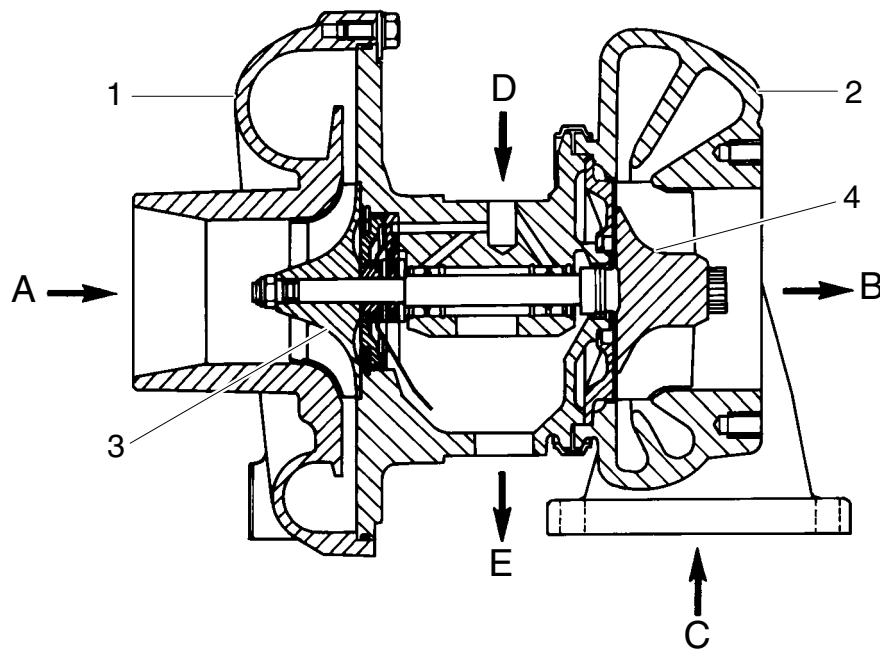

- 1 Compressor casing
- 2 Turbine casing
- 3 Compressor wheel
- 4 Turbine rotor

- A Air inlet
- B Gas outlet
- C Gas inlet
- D Oil inlet
- E Oil return

Intercooler (D 2866 LE, LXE)

Before entering the cylinders the combustion air compressed in the turbocharger is passed through a heat exchanger (intercooler).

Heat removal in the cooler is either by air (air-to-air intercooler) or, in case of the marine application, by means of seawater (air-to-water intercooler) delivered by the raw water pump.

It is important to provide a seawater filter ahead of the air-to-water intercooler.

In the case of extended standstills, cleaned seawater may be left in the intercooler, but dirty water (brackish water) must definitely be discharged.

The seawater-operated intercooler must be regularly cleaned as required in order to maintain its full cooling efficiency. If the engine output is found to drop, the reason may be in a fouled-up intercooler. The intercooler has to be removed from the engine for cleaning.

Cooling

The engine has a liquid-cooling system.

The water pump is a maintenance-free impeller pump driven by V-belts from the crankshaft pulley.

Depending on the agreed extent of delivery and the design of the engine, the coolant circuit can be equipped with temperature and level monitors which, in the event of overheating, will trigger an advance warning system or, in the event of loss of coolant, shut the engine down.

Air cleaner

Air cleaner is mounted on the engine to purify the air for combustion.

The intervals at which the air cleaner requires servicing depend on the specific operating conditions encountered. Clogged air filters may cause black smoke and reduce power.

A check should be made from time to time to see that the fastening elements securing the air cleaner to the intake manifold seal the connection tightly. Any ingress of unfiltered air is liable to cause a high rate of cylinder and piston wear.

Electrical equipment

Alternator

The alternator is fitted with integral silicon rectifiers.

A transistorized regulator mounted on the alternator limits the alternator voltage. The alternator should not be operated except with the regulator and battery connected in circuit to avoid damage to the rectifier and regulator.

The alternator is maintenance-free. Nevertheless, it must be protected against dust and, above all, against moisture.

Operate the alternator according to the instructions given in the chapter "Commissioning and operation".

Starter motor

The sliding-gear starter motor is flanged to the rear of the flywheel housing on the right-hand side.

As part of every engine overhaul, the starter pinion and ring gear should be cleaned with a brush dipped in fuel and then a coat of grease should be applied again.

Always protect starter motor against moisture.

Warning:

Always disconnect the battery earth cable before starting work on the electrical system. Connect up the earth cable last, as there is otherwise a risk of short-circuits.

Preparations

At the time of initial commissioning of a new or overhauled engine make sure to have observed the “Technical Information for the installation of MAN Diesel engines”.

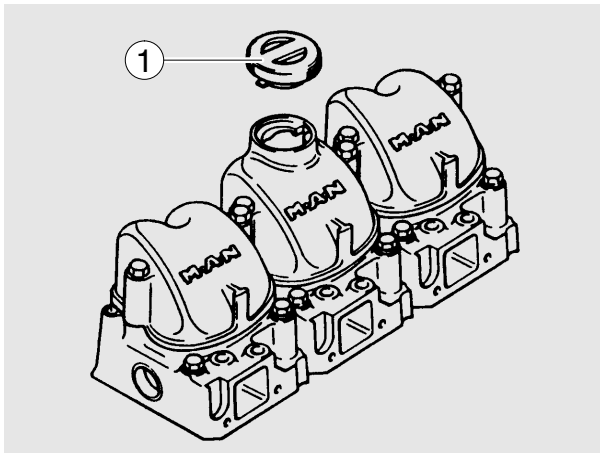

1 Oil filler neck on valve cover

Before daily starting the engine, check fuel level, coolant level and engine oil level and replenish, if necessary.

The notches in the dipstick indicate the highest and lowest permissible oil levels.

Marking the dipstick

As a rule oil dipsticks of marine propulsion engines are not marked by the manufacturer since the final installed position is unknown. Therefore, they should be marked after engine installation.

Proceed as follows:

- Fill with minimum oil quantity recommended for the respective engine type. After this initial filling wait about 1/2 hour until the entire oil has collected in the oil sump
- Pull out dipstick and mark minimum oil level visible on dipstick

- Thereafter fill up to maximum oil sump capacity, wait about 1/2 hour and mark maximum oil level visible on dipstick
- After refilling with oil, rotate the engine with the starter and move the shut-down lever to “stop” at the same time until the oil pressure warning light goes out and the oil pressure gauge shows a pressure. Then start the engine and allow it to run at medium speed for a few minutes. Check oil pressure and tightness of system. Then shut down the engine. After about 20 minutes, check the oil level. The oil level should now be at the upper notch of the dipstick, but not higher. Add any necessary oil to the upper dipstick mark.

Caution:

Do not add so much engine oil that the oil level rises above the max. marking on the dipstick. Overfilling will result in damage to the engine.

The oil required in the sump is specified in the “Technical Data” at the end of these Instructions.

Note:

The oil required to fill the oil filters and pipes depends upon the engine equipment and use and must be determined individually at the time of initial commissioning (Make a note of the determined quantity).

Ensure utmost cleanliness when handling fuels, lubricants and coolants.

Use only approved fuels, lubricants etc. (see brochure “Fuels, lubricants etc.”). Otherwise the manufacturer’s warranty will become null and void.

Raw water pump

Do not let raw water pump run dry.
Make sure that all valves / cocks in the raw water circuit are open.
If there is a risk of frost, drain the raw water pump.

Starting

Insert key in starting lock.

Press starter button, moving control lever against stop "maximum engine speed".

Do not operate starter for longer than 10 seconds at a time.

After ignition of the engine, release the starter button and adjust control lever for desired speed.

If engine fails to start, release the key, wait about 30 seconds, then operate starter again.

Avoid running the cold engine for any length of time since in any internal combustion engine this is liable to cause increased wear due to corrosion. Prolonged idling is harmful to the environment.

Note:

On initial start of an overhauled engine or after long periods without use, press shut-down lever in "stop" position and operate starter motor for a few seconds (max. 10) until oil pressure is indicated. Only then the engine should be started in the normal way.

Running in

It is recommended that new or overhauled engines should not be operated at a load higher than about 75% maximum load during the first few hours of operation. Initial run-in should be at varying speeds. After this initial run-in, the engine should be brought up to full output gradually.

During operation

Do not overload the engine. Do not exceed the maximum permissible engine tilt. If faults occur, find their cause immediately and have them eliminated in order to prevent more serious damage!

During operation the oil pressure in the engine lubrication system must be monitored. If the monitoring devices register a drop in the lube oil pressure, switch off the engine immediately.

The coolant temperature should be approx. 80 to 85°C.

The charge warning light of the alternator should go out when the engine is running.

Alternator

In order to avoid damage to the alternator, observe the following instructions:

While the engine is running

- Do not de-energize the main battery switch!
- Do not disconnect the battery or pole terminals or the cables!
- If, during operation, the battery charge lamp suddenly lights up, stop the engine immediately and remedy the fault in the electrical system!
- Do not run the engine unless the battery charge control is in satisfactory order!
- Do not short-circuit the connections of the alternator with those of the regulator or said connections with ground, not even by briefly bringing the connections into contact!
- Do not operate the alternator without battery connection!

Shutting down

Disengage the gearbox clutch and move the shut-down lever to “stop”. After the engine has been running at a high load level, do not shut it down immediately but allow it to idle about 5 minutes so that temperatures may equalize.

Remove key from starting lock.

Caution:

Ensure that the engine can not be started by unauthorized persons.

Temporary decommissioning of engines

Temporary anti-corrosion protection according to MAN works norm M 3069 is required for engines which are to be put out of service for fairly long periods.

The works standard can be obtained from our After-Sales Service department in Nuremberg.

Engine lubrication

Oil level

Check the oil level in the engine sump daily with a dipstick. The level should be between the two notches cut into the dipstick and should never be allowed to drop below the lower notch.

Caution:

Do not add so much engine oil that the oil level rises above the max. marking on the dipstick. Overfilling will result in damage to the engine.

The oil level should be checked with the engine horizontal and only after it has been shut down for about 20 minutes.

Oil drainage

With the engine at operating temperature, remove the oil drain plugs on the oil sump and the oil filter bowl and allow the old oil to drain off completely. Use a vessel of sufficient size to ensure that the oil does not overflow. Refit the oil drain plugs with new gaskets.

Caution:

The oil is hot- risk of scalding. Do not touch the oil drain plug with bare fingers. Oil is an environmental hazard. Handle it with care!

Refilling with oil

Refill with fresh engine oil at the oil filler neck.

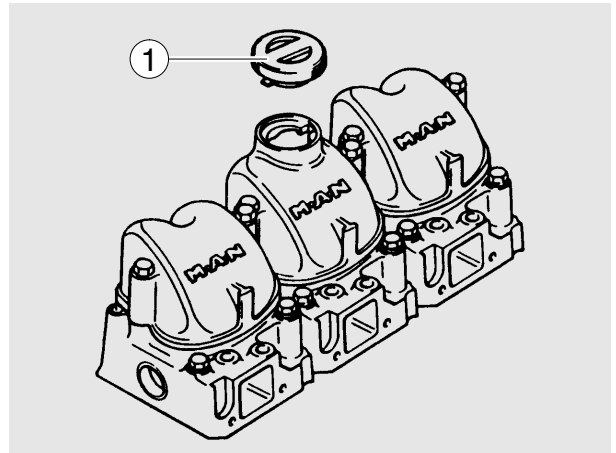

1 Oil filler neck on valve cover

After refilling with oil, rotate the engine with the starter and move the shut-down lever to “stop” at the same time until the oil pressure warning light goes out and the oil pressure gauge shows a pressure. Then start the engine and allow it to run at medium speed for a few minutes. Check oil pressure and tightness of system. Then shut down the engine. After about 20 minutes, check the oil level. The oil level should now be at the upper notch of the dipstick, but not higher. Add any necessary oil to the upper dipstick mark.

Note:

Refer to maintenance chart for compulsory oil change intervals and oil quality for D 2866 TE engines having higher ratings.

Lubricating oil filter

Cleaning of the lubricating oil is effected in a full-flow oil filter with paper cartridges. A bypass valve ensures continuity of oil supply if the filter elements should be clogged.

After draining off the oil, release tie screw. Remove filter bowl. Renew filter cartridge. Thoroughly clean all other parts in cleaning fluid. Use new gaskets for re-assembly

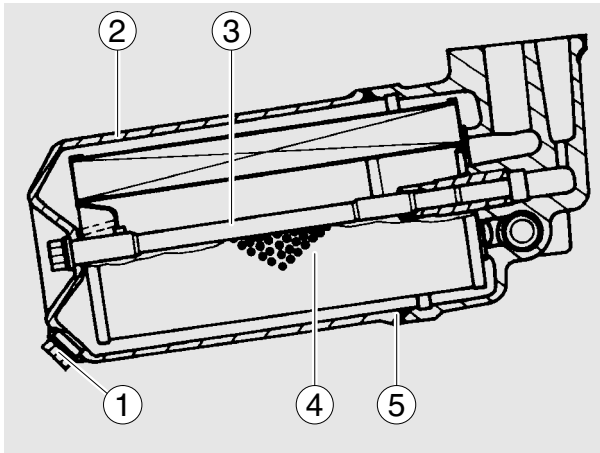

- 1 Oil drain plug
- 2 Oil filter bowl
- 3 Tie screw
- 4 Filter cartridge
- 5 Gasket

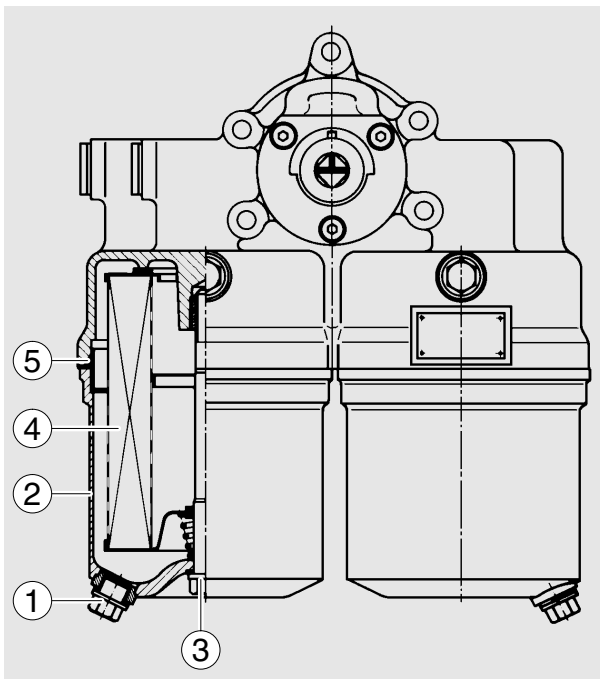

- 1 Oil drain plug
- 2 Oil filter bowl
- 3 Tie screw
- 4 Filter cartridge
- 5 Gasket

A changeover-type oil filter, the filter elements of which can be replaced even during operation, can be fitted on request. During continuous operation position the selector lever that both filter halves are in operation.

Observe positions of selector lever!

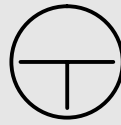

Continuous operation
(both filter halves
in operation)



Right-hand filter
cut out



Left-hand filter
cut out

Caution:

Do not leave selector lever in any intermediate position because this would be liable to interfere with oil supply.

Renewal of filter cartridges

- Allow the filter content to run off along drain plugs. Hold a suitable vessel under hole

Caution:

Oil is hot and under pressure!

- After releasing the clamping bolts remove filter bowls
- Renew filter cartridges. Thoroughly clean all other parts in cleaning fluid (do not allow cleaning fluid to enter the oil circuit)
- Use new gaskets for reassembly of filter bowls

Note:

To prevent the seal from twisting hold the filter bowl firmly when tightening the tensioning screw

Every time an oil change is made, the two oil filter cartridges should be renewed!

Caution:

Used oil filters are classed as dangerous waste and must be disposed of accordingly.

Fuel system

Fuel

If Diesel fuel which contains moisture is used the injection system and the cylinder liners / pistons will be damaged. This can be prevented to some extent by filling the tank as soon as the engine is switched off while the fuel tank is still warm (formation of condensation is prevented). Drain moisture from storage tanks regularly. Installation of a water trap upstream of the fuel filter is also advisable. Do not use any additives to improve flow properties in winter.

Injection pump

No alterations must be made to the injection pump. If the lead seal is damaged the warranty on the engine will become null and void.

Faults

We urgently recommend that you have faults in the injection pump rectified only in an authorised specialist workshop.

Bleeding the fuel system

Bleeding the fuel filters is by releasing the bleed screws and operating the manual primer (fit new seals).

The suction chamber of the injection pump is continuously bled via the relief valve during operation. If the suction chamber is completely empty, e.g., when fitting a new pump, filling and bleeding it is by actuating the manual primer.

Fuel lift pump

The fuel lift pump is operated by the injection pump camshaft via the roller tappet.

Strainer

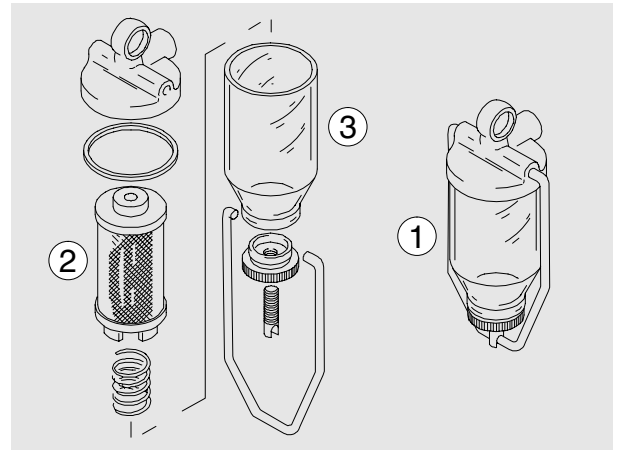

- 1 Fuel strainer
- 2 Filtering screen
- 3 Filter housing

After every 200 hours of operation the fuel strainer connected upstream of the fuel lift pump should be cleaned.

Fuel filter

After every 1000 hours of operation – or earlier if loss of engine power indicates clogging – the filter elements should be renewed.

Two-stage fuel filter

(replaced by parallel fuel filter)

In two filter housings connected in series the fuel first passes through a felt tube element and then through a paper element.

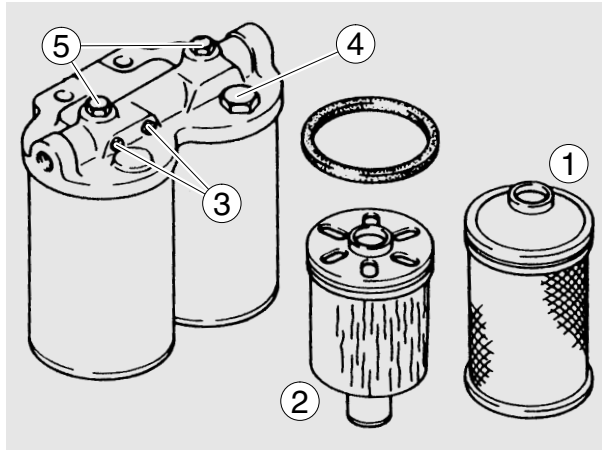

- 1 Felt tube element (primary filter)
- 2 Paper element (secondary filter)
- 3 Vent plugs
- 4 Filler plug
- 5 Clamping screws

Replacement of filter elements

- Remove clamping bolts
- Take off filter bowls
- Take out filter elements
- Wash out filter bowls
- Install new filter cartridges
- Refit filter bowls using new gaskets
- Open vent plug for primary filter (felt tube element). Fit new seals
- Operate manual fuel lift pump until fuel is emitted without any bubbles
- Close vent plug on primary filter
- Bleed secondary filter in the same manner

Parallel fuel filter with filter cartridges

(replaced by parallel filter with interchangeable filter)

The fuel passes through two filter elements connected in parallel.

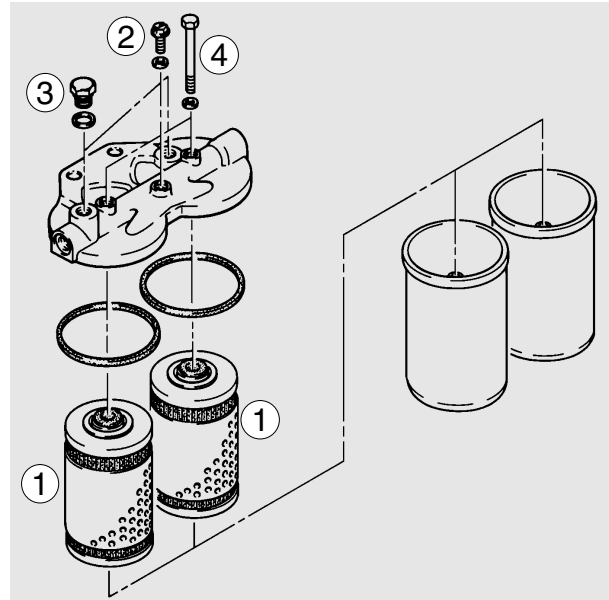

- 1 Filter elements
- 2 Vent plugs
- 3 Filler plug
- 4 Clamping screws

Replacement of filter elements

- Remove clamping bolts
- Take off filter bowls
- Take out filter elements
- Wash out filter bowls
- Install new filter cartridges
- Refit filter bowls using new gaskets
- Open vent plug (fit new seals)
- Operate manual fuel lift pump until fuel is emitted without any bubbles
- Close vent plug

Parallel fuel filter with interchangeable filter

The fuel flows through two parallel filters.

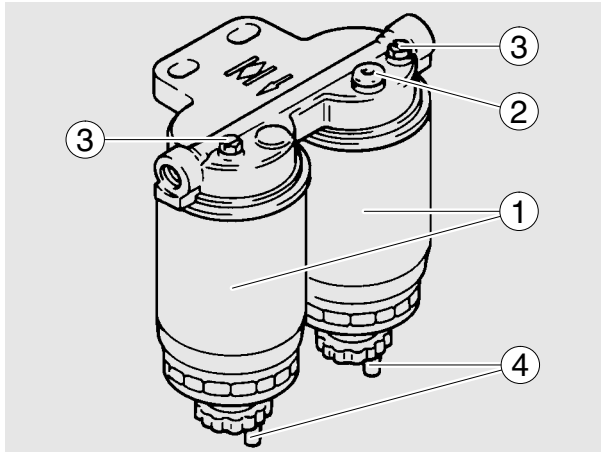

- 1 Filter cartridge
- 2 Screw plug
- 3 Bleed screw
- 4 Moisture drain plugs

Draining moisture:

Unscrew drain plugs at every oil change until moisture has been discharged and clean fuel flows out.

Replacement of filter elements:

After every 1000 hours of operation – or earlier if loss of engine power indicates clogging – the filter elements should be renewed.

Caution:
Used fuel filters are classed as dangerous waste and must be disposed of accordingly.

Change-over fuel filter with filter cartridges

(replaced by change-over fuel filter with interchangeable filter)

Where the changeover-type filter is installed, the servicing procedure is for the filter side requiring to be shut off with the engine running. During continuous operation, the selector lever should be placed in a position where both filter halves are in operation.

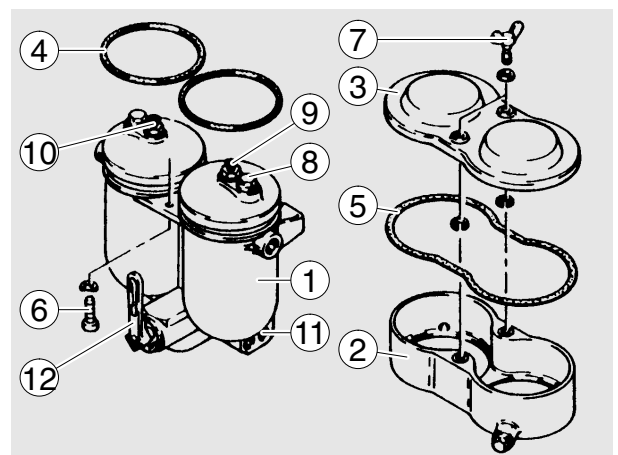

- 1 Changeover type filter
- 2 Collecting vessel
- 3 Cover for collecting vessel
- 4 O-ring
- 5 Gasket
- 6 Fixing bolts for collecting vessel
- 7 Screw nut
- 8 Filler plug
- 9 Vent plug
- 10 Fixing nut
- 11 Sludge drain plug (socket head width across flats 5)
- 12 Selector lever

Caution:

Do not leave selector lever in any intermediate position because this would be liable to interfere with fuel supply. If in doubt stop the engine to change the fuel filter.



Continuous operation
(both filter halves
in operation)



Right-hand filter
cut out



Left-hand filter
cut out

To replace filter element

- Move selector lever to position where filter side to be cleaned is cut out
- Slacken vent plug 1 or 2 turns (fit new seals)
- Allow filter to drain through sludge drain plug
- Take off filter cover on slackening fixing nut
- Withdraw filter element and flush filter chamber with clean fuel
- Install new element
- Fit filter cover using new gasket
- Fill filter bowl through filler opening with fuel. Close vent plug
- Position selector lever so that both filters are in circuit

Change-over fuel filter with inter-changeable filter

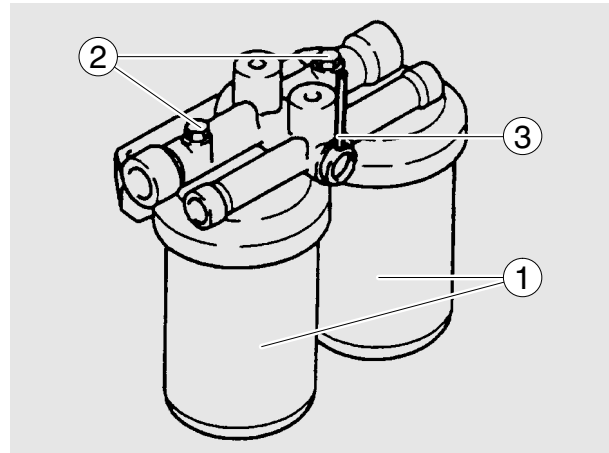

- 1 Filter cartridge
- 2 Bleed screw
- 3 Selector lever

Replacement of filter elements:

After every 1000 hours of operation – or earlier if loss of engine power indicates clogging – the filter elements should be renewed.

Caution:

Used fuel filters are classed as dangerous waste and must be disposed of accordingly.

Injector maintenance

(by authorized specialist personnel)

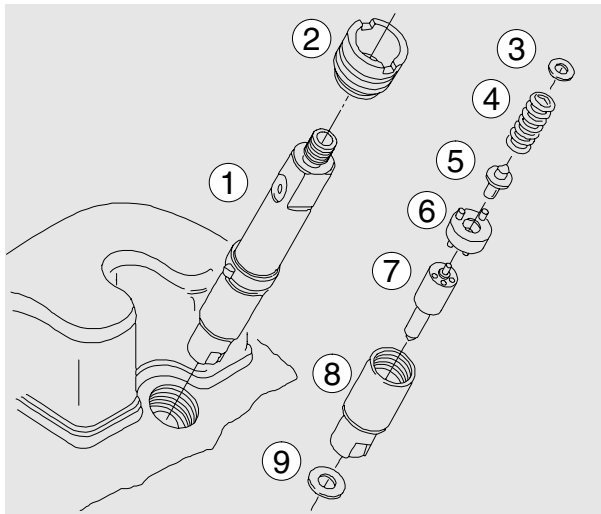

- 1 Nozzle holder
- 2 Union screw
- 3 Washer
- 4 Compression spring
- 5 Thrust pin
- 6 Intermediate disc
- 7 Injection nozzle
- 8 Nozzle nut
- 9 Gasket

The injectors are designed to spray the fuel delivered by the injection pump directly into the spherical combustion chamber in the piston crown.

The injector consists of the nozzle and the nozzle holder.

A copper gasket fitted to the injector ensures gas-tight seating and good heat dissipation.

The opening pressure of the nozzle is adjusted by means of shims at the compression spring.

Removal, dismantling and cleaning

Unscrew delivery pipe at nozzle holder and at the injection pump.

Remove leak-off pipe.

Release union screw of nozzle holder with special wrench.

Remove nozzle holder with gasket from the cylinder head.

Note for cleaning nozzles with Bosch cleaning set KDEP 2900

Clean nozzle body externally from soot and carbon. When cleaning several nozzles at the same time, make sure nozzle bodies and needles are not mixed up. Visually inspect needle and body. Cleaning is useless if the seat of the needle is indented or the pintle is damaged and the nozzle should be replaced.

Clean annular groove with scraper over full circumference. Wash out dislodged carbon deposits and dirt.

Scrape needle seat with cleaning cutter. Dip cutter in test oil before use. The cutter can also be clamped in a lathe.

Polish needle seat with wooden cleaning tool, preferably by chucking the needle in a lathe at the pintle end.

Clean the spray holes of hole nozzles using the cleaner KDEP 2900/2 by chucking a cleaning needle of suitable diameter in the collet. If the carbon deposits in the spray holes cannot be removed by rotating and pressing, have the needle project only slightly from the collet and drive out the carbon by lightly tapping on the tool.

Before reassembly thoroughly wash nozzle body and needle in clean test oil.

Hold the needle at the pintle end only; to avoid corrosion do not touch the lapped surfaces of the needle with your fingers.

Thoroughly clean all other parts of the nozzle holder with clean fuel.

Check nozzle discharge pressure in nozzle tester.

The edge-type filter should not be pressed into the nozzle holder by approx. 5 mm.

If this depth is exceeded the injector must be replaced.

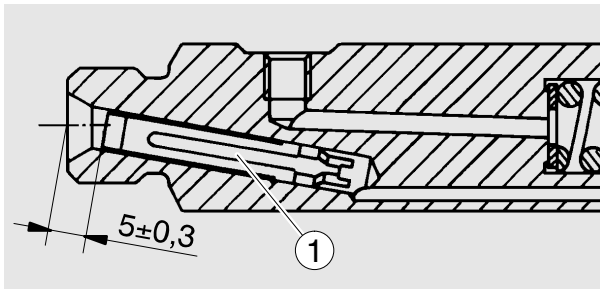

1 Edge-type filter

Check nozzle discharge pressure in nozzle tester. Adjust the discharge pressure by inserting shims of suitable thickness under the compression spring.

Caution:

Do not hold your hands under the fuel jet, as there is a risk of injury. Do not inhale the atomised fuel. If possible work under an extraction system.

Installation

Clean seat in cylinder head.

Insert nozzle holder with new gasket. Tighten union nut with 120 Nm.

Install injection lines free of constraint. Install leak fuel lines.

Caution:

The injection lines are designed for high operating pressures and should thus be handled with particular care.

- When mounting the pipes to the engine take care of good fitness
- Do not bend pipes to permanent deformation (not for replacing the nozzles either)
- Do not mount any heavily bent pipes
- Avoid bending the pipes at the ends by more than 2 to 3 degrees
- In case of faults in the injection system which might have resulted in excessive operating pressures, not only the failed part but also the injection line has to be replaced

Cooling

Fill the cooling system of the engine with a mixture of drinkable tap water and anti-freeze agent on ethylene glycole basis or anti-corrosion agent.

See Publication “Fuels, Lubricants and Coolants for MAN Diesel Engines”.

Filling-in of coolant (only when engine has cooled down)

- Fill in the coolant slowly
- Make sure that all air can escape from the cooling system
- Run the engine briefly and then check coolant level once more

If, in an **exceptional** case, the coolant level has to be checked in an engine that has reached operating temperature, first carefully turn the cap (large cap) with safety valve to the first stop, let off pressure, then open carefully.

Coolant must be added at the filler neck only. Do not put cold coolant into an engine which is warm from operation.

Ensure that the ratio of water to anti-freeze is correct. Find the cause of the loss of coolant and have it eliminated.

Warning:

If the cap with the working valves is opened, there is the risk that it will not close tightly again afterwards. The excess pressure required in the system will then no longer build up. Premature boiling occurs and coolant is lost. To prevent damage to the engine open this cap only in exceptional circumstances and fit a new one as soon as possible.

Draining of coolant

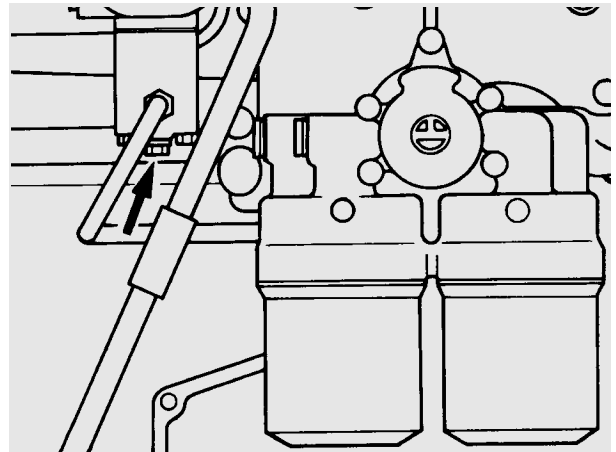

Drain plug in oil cooler housing cover (for engines with liquid-cooled turbocharger)

Drain coolant as follows when cooling system has cooled down:

- Remove cover from filler neck of surge tank
- Remove drain plug in crankcase, oil cooler housing and exhaust manifold

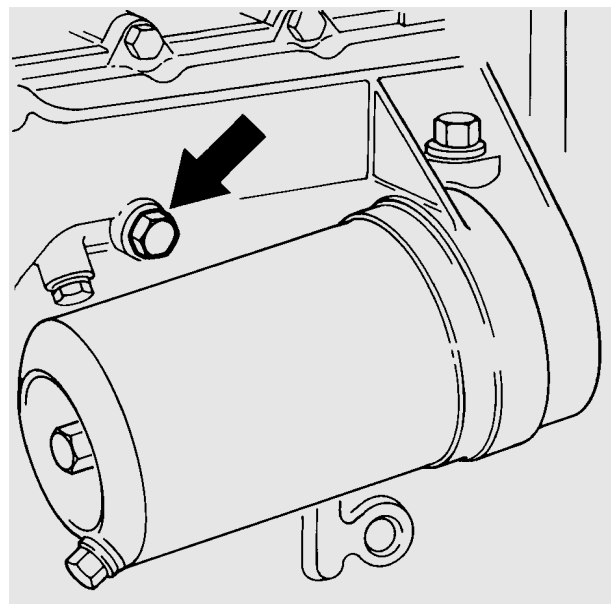

Drain plug in oil cooler housing

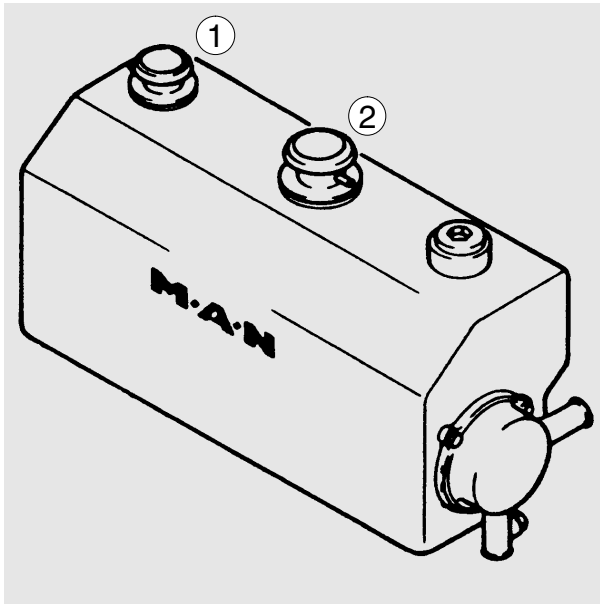

- 1 Working valve
2 Filler cap

Improper mixing of anti-freeze and corrosion inhibitors may lead to lime and corrosion deposits in the engine cooling system which can jeopardize cooling efficiency.

In such cases it is necessary to clean the cooling system at suitable intervals.

Cleaning the outside of the radiator (wear goggles)

Extreme dirt deposits can clog the honeycombs so that the remaining surface no longer ensures sufficient cooling. In such cases, the insects, dust etc. should be removed from the honeycomb system of the radiator block and the radiator itself then cleaned with the cleansing agent HENKEL P3-begesol. This cleansing agent is available from MAN in 10-kg cans under Part No. 09.21002-0164.

Procedure:

- Mix P3-begesol with water, ratio 1:1
- Using a spray gun, spray the mixture in as straight a jet as possible directly into the radiator fins

- Let the mixture work for 5 minutes
- Hose down the radiator with a straight jet of tap water directly from the front. In cases of stubborn dirt deposits remove the radiator and hose it down directly from behind. Do not use high-pressure cleaners (steam sprayers may be used)

Henkel P3-begesol contains no toxic or corrosive substances and, if handled properly, may be used without hesitation.

Cleaning the inside of the cooling system

(by authorized specialist personnel)

Investigations have shown that in many cases the poor condition of the coolant and / or the cooling system accounts for damage to the water pump mechanical seal. The poor condition of the cooling system is normally due to use of unsuitable or no anti-freezing agents and corrosion inhibitor or defect, not early enough replaced covers for filler neck and working valves.

If twice in a short time the water pump of an engine develops leaks or the coolant is heavily contaminated (dull, brown, mechanically contaminated, grey or black signs of a leakage on the water pump casing, after the defect on the oil cooler) clean the cooling system **prior to** removing that water pump as follows:

- a) Drain coolant
- b) Open thermostats positively (use short-circuit inserts), so that the entire coolant circuit is flushed in the cleaning operation
- c) Fill coolant circuit with a mixture of hot water (min. 50°C) and Henkel P 3 neutral 5265 detergent (1.5% by volume) (-5266, -5225, Kluthe Hakopur 316), see Publication "Fuels, Lubricants ..."

- d) Warm up engine under load. After a temperature of 60°C is reached, run engine for a further 15 minutes
- e) Drain cleaning fluid
- f) Repeat steps c) and d)
- g) Flush cooling system. To this effect
- h) Replace drain plug by drain plug with a bore of 8 mm dia
- i) Fill cooling system with hot water
- k) Run engine at idle for 30 minutes. At the same time continuously replenish the water leaking from the bore in drain plug by adding fresh water

- Drain the pickling fluid, fill the system with tap water, and run the engine at idle for 5 minutes to flush out all fluid; then drain the water
- Fill the system with a 1% soda solution. Drain the soda solution after running the engine at idle for 5 minutes, and flush with tap water until the discharging water is clear
- Fill cooling circuit with a mixture of potable tap water and anti-freeze with at least 40% by volume, refer to Publication "Fuels, Lubricants ..."

Repair water pump only now. Thereafter, fill the cooling system with approved cooling fluid. See Publication "Fuels, Lubricants ...".

Note:

Only sediments and suspended particles can be removed by this cleaning method. If corrosion and lime deposits are found, proceed according to the following section:

Note:

Older radiators may develop leaks when such deposits are removed. The surge tank should be filled only up to the bottom edge as otherwise foaming will cause the pickling fluid to spill over.

Removal of lime deposits in the cooling system

(by authorized specialist personnel)

Procedure:

- Drain the coolant
- Fill the system with undiluted original pickling fluid (Lithsolventsäure or engine pickling fluid RB-06), see sources of supply
- Let the engine run (also in normal operation) for approx. 8 hours with this filling in the cooling circuit
- Drain the pickling fluid and thoroughly flush the system with tap water
- If necessary, refill the circuit again with fresh pickling fluid and pickle the engine for another 8 hours

Cleaning the inside of tube bundles of raw water heat exchangers

(by authorized specialist personnel)

Deposits building up inside the tube bundle of the water-to-water heat exchanger can reduce the flow cross-section of the individual tubes to the point where a decrease in engine cooling occurs. This condition will automatically lead to overheating of the engine with all of its accompanying effects. For this reason, it is recommendable to clean the tube bundle of the water-to-water heat exchanger at the first sign of high engine coolant.

Procedure:

- Remove and dismantle the heat exchanger (integrated in the coolant surge tank)
- Place the removed tube bundle in a suitable container made of plastic, such as PE, PP, PVC, GFK

- Fill the container with undiluted original pickling fluid at room temperature (Lithsolventsäure or engine pickling fluid RB-06) until the tube bundle is completely immersed
- Allow the pickling fluid to work approx. 10 hours. If this time is not sufficient, continue the pickling process for up to 5 hours
- Pickling can be shortened by heating up the fluid (max 50°C) and by occasionally moving the tube bundle
- After pickling thoroughly flush the bundle with tap water and reinstall in the heat exchanger
- Use new gaskets (O-seals)
- Mount the heat exchanger on the engine and check for tightness

Note:

The variety of dirt deposits may also create problems for the method of pickling described above. In such cases, we ask you to first of all submit a specimen of the deposit for further examination.

Damaged tube bundles may develop leaks when dirt deposits are removed.

Filler caps and working valves of cooling system

The rubber gaskets of the filler caps and working valves (negative pressure and positive pressure valves) of the cooling system are subject to natural aging.

To preclude leakages in the cooling system and tailing pressure drop and its consequences up to severe engine damage, renew the filler caps and working valves in line with the change of coolant (every two years at the latest).

Waste water treatment

Drained and spent cleaning and pickling fluid should be brought up to a pH value of 7.5 to 8.5 with the aid of caustic soda. Once the precipitation has settled to the bottom of the container the clear fluid above can be dumped into the sewer. The sludge at the bottom should be taken to a special waste dump. Anyway, it is recommended to consult the local authorities for more information about waste water rules or restrictions.

Sources of supply for pickling fluids

Lithsolventsäure

Keller & Bohacek
Liliencronstr. 54
D-40472 Düsseldorf
Phone: (02 11) 96 53 0

Motor pickling fluid RB-06

Reincolor-Chemie GmbH
Werkstr. 21
D-90518 Altdorf
Phone: (0 91 87) 97 03 0

Turbocharger

Maintenance

(by authorized specialist personnel)

The turbochargers do not call for any specific maintenance.

The only points to be observed are the oil pipes which should be checked at every oil change for leakage and restrictions.

The air cleaners should be carefully serviced.

Furthermore, a regular check should be kept on charge air and exhaust gas pipes. Any leakages should be attended to at once because they are liable to cause overheating of the engine.

When operating in highly dust or oil-laden atmospheres, cleaning of the air impeller may be necessary from time to time. To do this, take compressor housing (**Caution: do not tilt it so that it jams**) and clean it in solvent (diesel oil, petroleum ether) using a brush.

If the air compressor should be badly fouled, it is recommended that the wheel be allowed to soak in a vessel with solvent and to clean it then with a stiff brush. In doing so, take care to see that only the compressor wheel is immersed and that the turbocharger is supported on the bearing casing and not on the wheel.

Special hints

It is recommended that the radial and axial clearances of the rotor be checked after every 3000 hours operation.

This precaution will enable any wear of the bearings to be detected in good time before serious damage is caused to the rotor and bearings.

Measuring of axial clearance

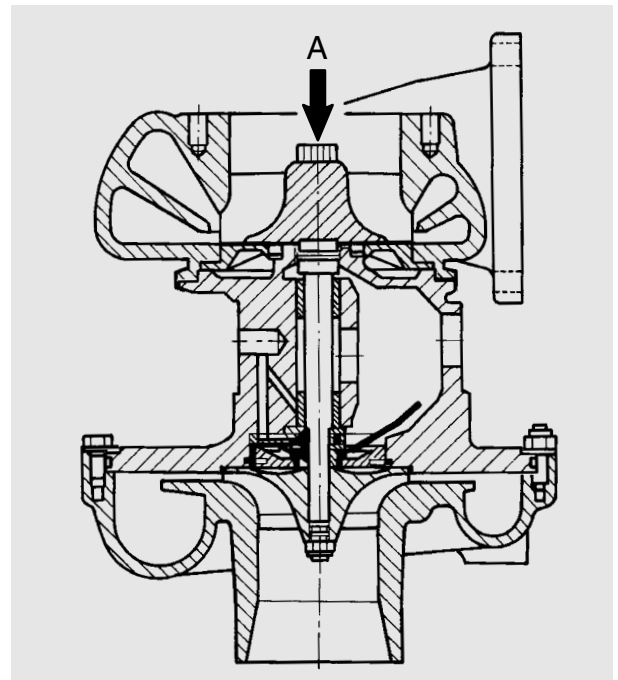

A = Measuring point for dial gauge

Measuring of radial clearance

(The radial clearance will be determined only at turbine end)

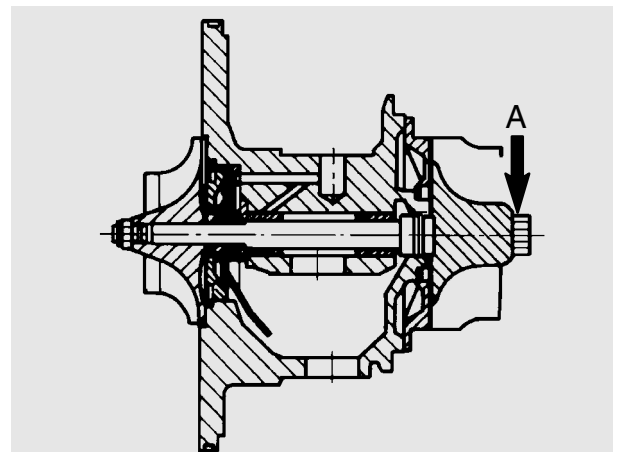

A = Measuring point for dial gauge

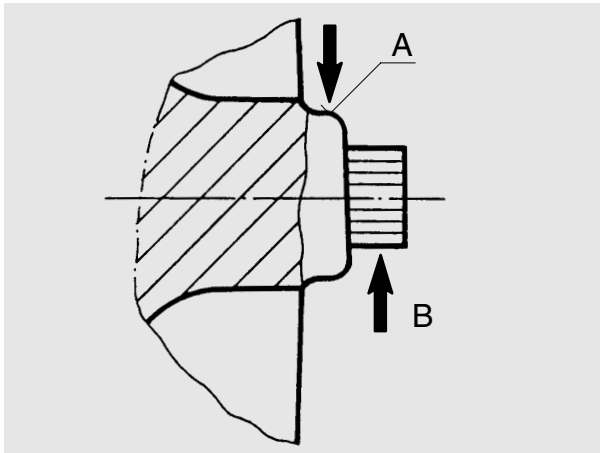

A = Point of support for dial gauge tip
B = Measuring capacity

Axial and radial clearances

	KKK model	axial (mm)	radial (mm)
D 2866 TE/LE/LXE with liquid-cooled exhaust manifold	K 36	0,16	0,58
D 2866 TE/LE/LXE with uncooled exhaust manifold	4LGZ	0,20	0,65

If excessive clearances are found, the turbocharger should be replaced.

Intercooler

Maintenance

(by authorized specialist personnel)

In order to maintain the heat transfer efficiency of the intercooler, it is necessary to clean it at regular intervals which depend on the quality of the coolant used.

For this purpose, dismantle the intercooler. In almost all cases, it will suffice to clean the individual parts in a hot alkaline solution, e.g. a 3 to 5% P3-FD solution.

Should hard and firmly adhering scale deposits continue to exist a second treatment should be made with a descaling agent which will not corrode the cooler core.

Use new gaskets when assembling the cooler.

Be sure to clean the sealing surfaces carefully before installing the gaskets.

Observe the specified pressure when making the hydraulic test.

Test gauge pressure	water side	4 bar
	charge air side	3 bar

Air cleaner

Dry air cleaner

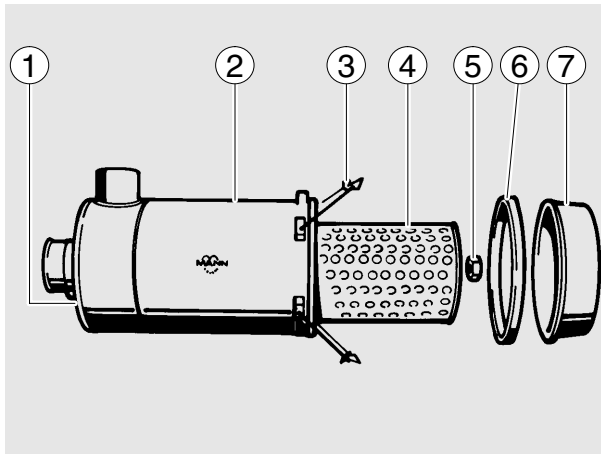

- 1 Connection port, fouling indicator
- 2 Cleaner housing
- 3 Clamp
- 4 Element
- 5 Hexagon nut
- 6 Cover
- 7 Dust bowl

Service only when engine is switched off.

Dust collector

The dust collector must be emptied at regular intervals. The collector should never be more than half full of dust.

When the two retainers have been folded up the dust collector can be taken off.

Remove the lid of the dust collector and empty the collector.

Ensure that the lid and the collector are reassembled correctly. A lug on the collector fits into a recess in the edge of the lid. If the filter is installed horizontally note the “oben” (“top”) marking on the filter bowl.

Fouling Indicator

As the degree of clogging increases the red indicator becomes more and more visible in the transparent section of the air cleaner.

If the fouling indicator remains engaged, i.e. it still shows completely red even with the engine shut down, the filter cartridge must be cleaned or replaced.

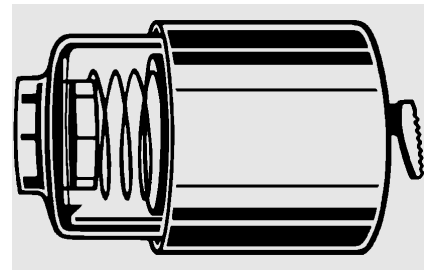

Filter operational

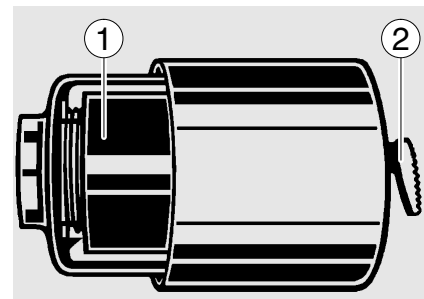

Filter must be serviced

- 1 Red indicator
- 2 Reset button

After servicing the cartridge, press the button to reset the fouling indicator.

Changing the filter cartridge

Caution:

No dust must get to the clear air end.

Remove the hex nut, take out the contaminated cartridge and fit a new one.

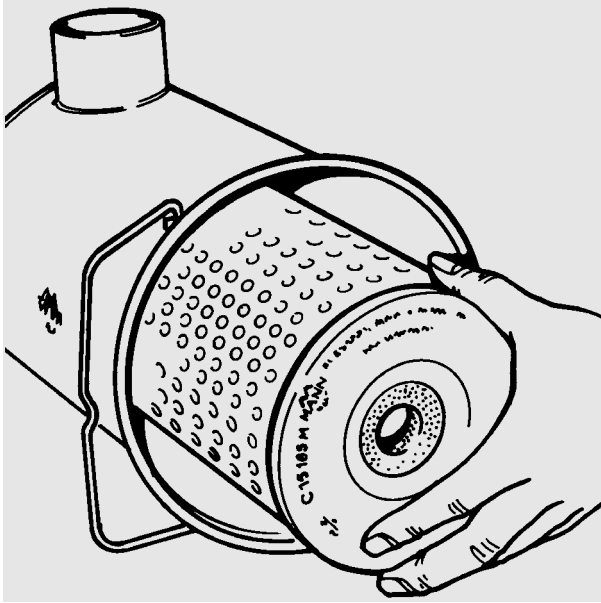

Clean the filter housing with a damp cloth, especially at the sealing face for the cartridge.

Caution:

The engine must not be run without a main cartridge.

Cleaning the cartridge

Caution:

The filter cartridge should normally be changed. Clean it only in emergencies (e.g. when no replacement is available).

Blowing out (wear goggles)

To do this fit a pipe to the compressed air gun. The end of the pipe should be bent by approx. 90°. The pipe must be long enough to reach the bottom of the cartridge.

Blow the cartridge out from the inside with dry compressed air (max. 5 bar) by moving the pipe up and down inside the cartridge until no more dust is released.

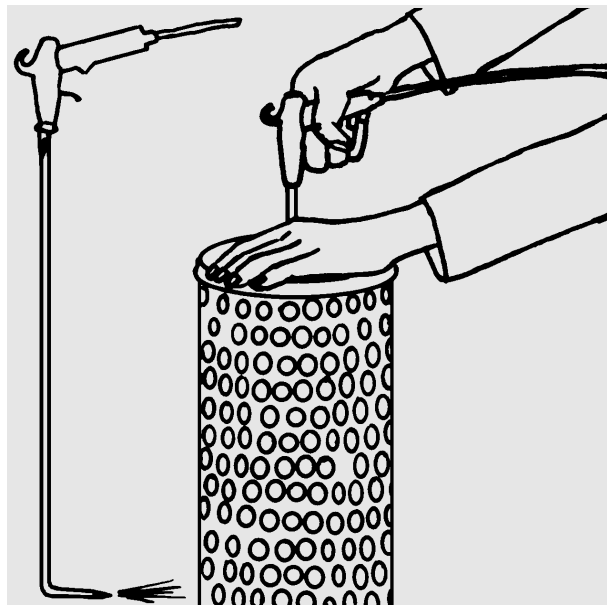

Checking the cartridge

When a cartridge has been cleaned it must be examined for damage before it is refitted, e.g. damage to the paper bag and rubber seals. Check also for compression of or dents in the metal jacket.

Tears and holes in the paper bag can be found by shining a torch into the bag.

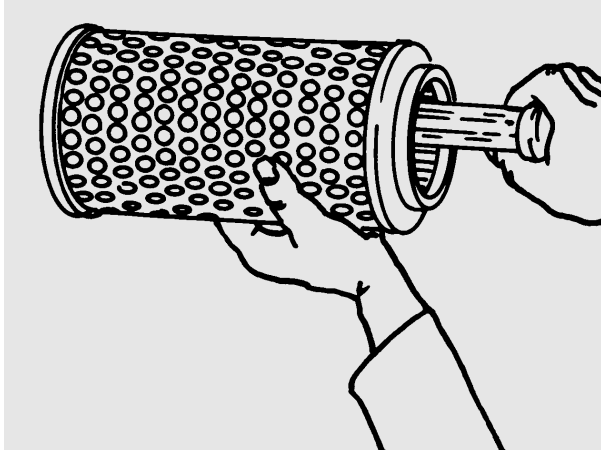

On no account re-use damaged cartridges. If in doubt fit a new cartridge.

Safety cartridge

When the main cartridge is being serviced the safety cartridge remains in the filter housing. The engine must not be run without the main cartridge.

Safety cartridges must be neither cleaned nor re-used.

Safety cartridges must be changed:

- at the latest after being in use for two years
- if, after the main cartridge has been serviced (changed), the contamination gauge responds again immediately
- if the main cartridge is defective

When the main cartridge has been removed the safety cartridge is accessible and can be removed also.

Remove the hex nut.
Pull out the safety cartridge.
Insert a new safety cartridge. Refit and tighten the hex nut.

Viscous air cleaner

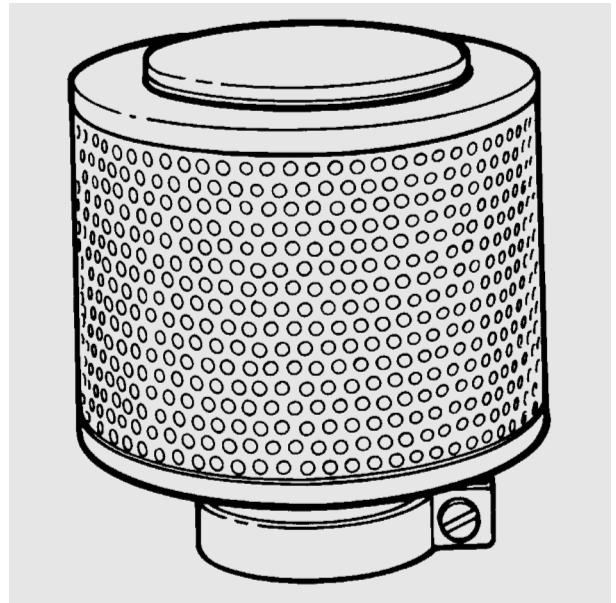

The maintenance intervals for filters depend on the respective operating conditions.

As soon as a distinct layer of dust has accumulated on the filter element, remove air cleaner and wash in fuel or cleaning oil.

Shake element out thoroughly to dry it.

Uniformly coat filter surface with a thin film of engine oil.

To check and set the start of delivery with start of delivery marker on injection pump hub

(by authorized specialist personnel)

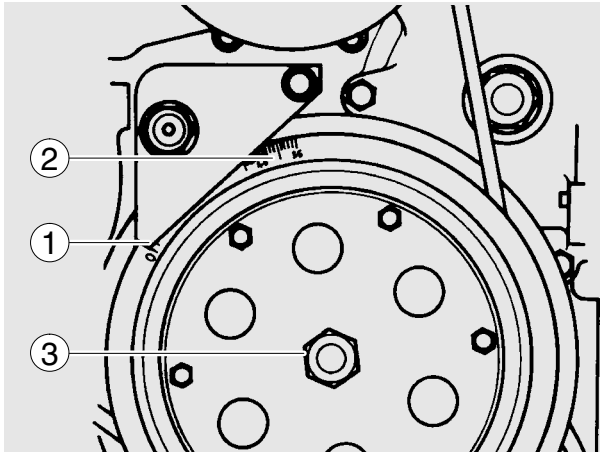

- 1 Setting pointer
- 2 "OT" (top dead centre) mark and scale
- 3 Hexagon driver to rotate engine by hand (Width across flats 32)

For the purpose of checking the start-of-delivery setting, an "OT" (top dead centre) mark and a scale from 10 ... 50° before top dead centre are engraved on a disc fitted in front of the torsional vibration damper. The scale marks are read against a pointer fitted to the crankcase.

There is another scale engraved on the flywheel which can be read through an inspection hole in the flywheel housing but access may be difficult. The scale should be used for readjusting the pointer after the vibration damper has been removed or replaced.

In other words, before the vibration damper with the scale disc is installed, the engine should be positioned at "OT" (top dead centre) by means of the scale on the flywheel.

The pointer should then be aligned such that its measuring edge exactly coincides with the "OT" mark on the scale disc.

In order to enable the engine to be rotated manually during adjustments, there is a plate with a central hexagon driver fitted to the front of the crankshaft pulley (bar-ring device).

Checking

Remove screw plug for inspection hole in mounting flange of the injection pump.

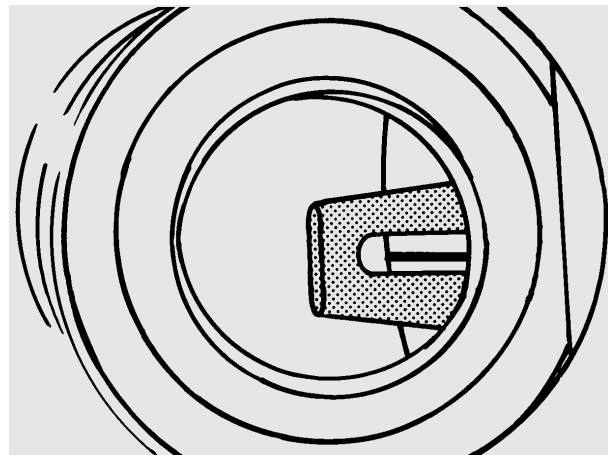

Then rotate engine so that mark on pointer fitted to injection pump coincides with mark on pump hub.

Read degrees on scale engraved on disc on torsional vibration damper.

The reading should equal the specified start-of-delivery setting (see "Technical Data").

If not, correct start-of-delivery setting.

Setting start of delivery

Correct start of delivery by turning the pump hub in the slotted holes of the drive gear.

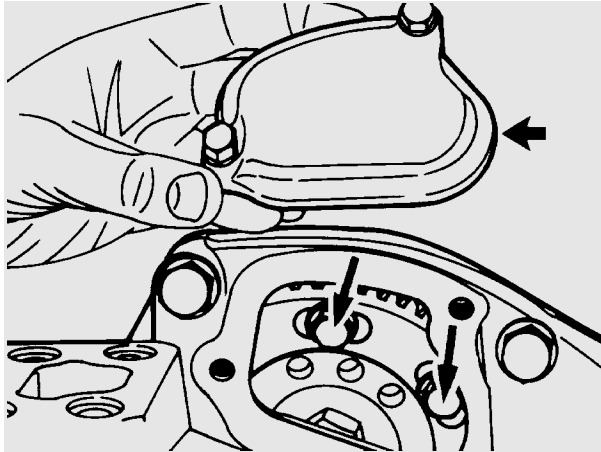

Remove cover above the injection pump drive gear

Rotate engine with barring device until the pointer is on the specified start of delivery (scale disc ahead of vibration damper).

Unscrew timing case cover. Remove fixing screws of injection pump impeller. Turn the hub of the injection pump accordingly until the line marks (pointer and injection pump hub) are in alignment. After every adjustment carefully retighten fixing screws.

Recheck start of delivery.

Use new gaskets when mounting cover and screw plug.

Note:

The D 2866 LE / LXE engines with fan-cooled radiator are not equipped with a scale disc in front of the torsional vibration damper. Start of delivery in these engines should be set by means of the degrees scale on the flywheel.

To check and set the start of delivery with start of delivery indicator in the governor housing

(by authorized specialist personnel)

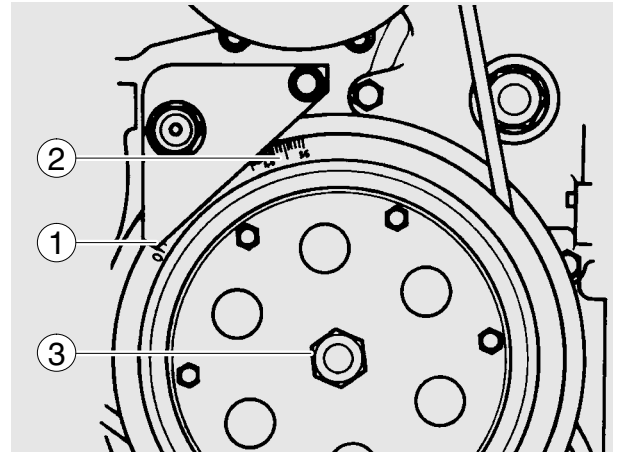

- 1 Setting pointer
- 2 "OT" (top dead centre) mark and scale
- 3 Hexagon driver to rotate engine by hand (Width across flats 32)

For the purpose of checking the start-of-delivery setting, an "OT" (top dead centre) mark and a scale from 10 ... 50° before top dead centre is engraved on a disc fitted in front of the torsional vibration damper. The scale marks are read against a pointer fitted to the crankcase.

There is another scale engraved on the flywheel which can be read through an inspection hole in the flywheel housing but access may be difficult. The scale should be used for readjusting the pointer after the vibration damper has been removed or replaced.

In other words, before the vibration damper with the scale disc is installed, the engine should be positioned at "OT" (top dead centre) by means of the scale on the flywheel.

The pointer should then be aligned such that its measuring edge exactly coincides with the "OT" mark on the scale disc.

In order to enable the engine to be rotated manually during adjustments, there is a plate with a central hexagon driver fitted to the front of the crankshaft pulley (bar-ring device).

Checking

Remove screw plug (1) on governor housing. If fitted, take out blocking pin (2). If the pointer is exactly in the centre of the inspection hole, the pump plunger for cylinder no. 1 is at start of delivery. However, it is possible to determine exactly whether or not the pump is at start of delivery only by means of the following special tools:

a. Light signal transmitter 80.99605-6002

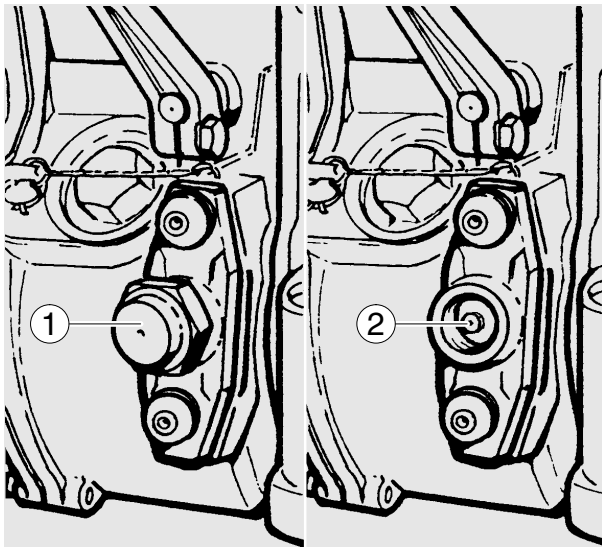

Push light signal transmitter into socket in governor housing. Ensure that the lug (3) fits in the groove (4). Tighten the knurled nut (5) by hand.

Connect up power supply of light signal transmitter (red terminal = +). Turn engine by hand so that piston in cylinder no. 1 in the compression stroke comes close to the start of delivery.

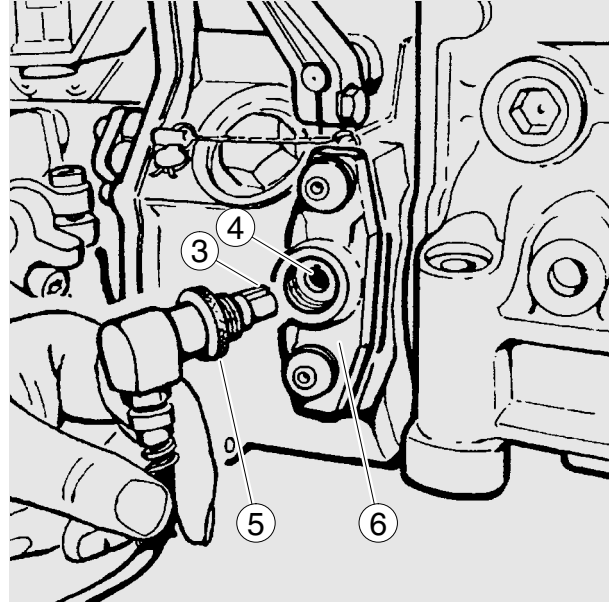

Lamp (A) comes on shortly before start of delivery is reached.

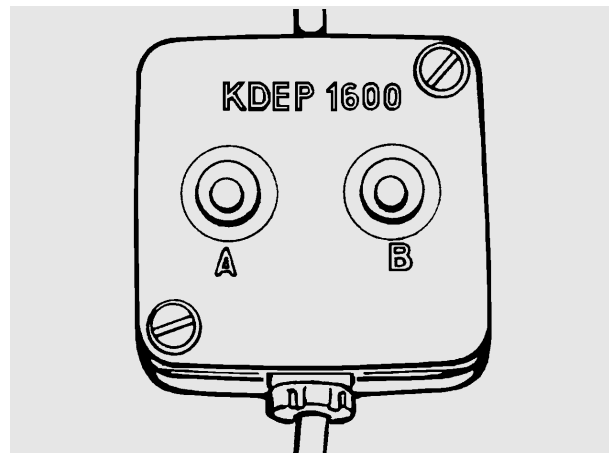

Slowly turn the engine further until lamp (B) comes on too. The injection pump is now at start of delivery.

When the pump is in this position the degree scale on the flywheel housing must also indicate the specified start of delivery.

Note:

If only lamp (B) comes on during this test the engine has been turned past the start of delivery. In this case turn the engine back and repeat the procedure.

b. Sleeve

If a light signal transmitter is not available, good measurement results can also be achieved with a plug-in receptacle.

The receptacle is to be made of aluminium or steel in accordance with the drawing (figure 2259).

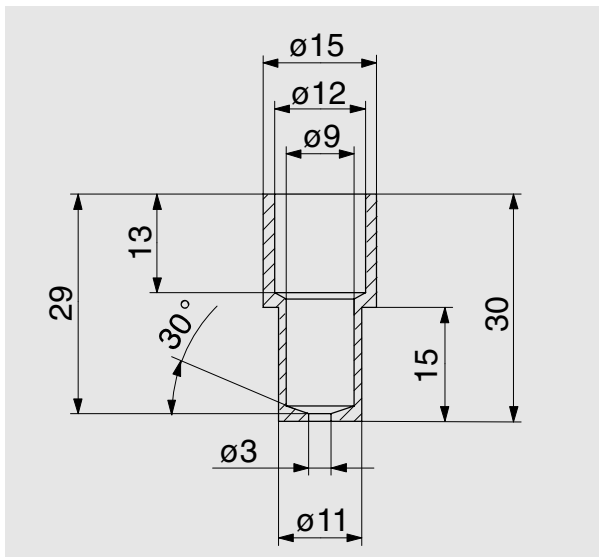

Set engine to start of delivery as described above.

Insert the sleeve into the governor housing up to the stop. The start of delivery is set exactly when the pointer for start of delivery is in the centre of the 3 mm bore in the sleeve.

Setting start of delivery

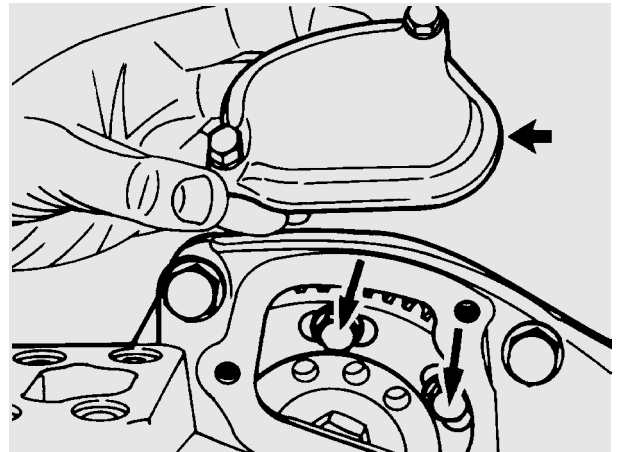

If the start of delivery as determined in the checks carried out in accordance with method a) or b) is not correct, proceed as follows:

Remove cover above the injection pump drive gear. Loosen the fixing bolts joining the drive gear to the injection pump hub.

Set the engine so that the cylinder no. 1 is at the specified number of degrees before firing top dead centre (TDC).

Remove screw plug on governor housing. The pointer for start of delivery must be visible in the centre of the inspection hole.

Turn the injection pump camshaft to the left or right as necessary until the conditions required for a) or b) (depending on which method is being used) are obtained.

After every adjustment carefully retighten fixing bolts.

Check start of delivery again. Close up governor housing.

To check and adjust valve clearance

(by authorized specialist personnel)

The valve clearance for new and overhauled engines should be checked after the first 10 to 20 hours of operation.

Then it should be adjusted every 400 hours of operation.

The valve clearance (see “Technical Data”) should be adjusted so that the feeler gauge can be moved between the valves stem and the rocker arm with a slight resistance being felt.

Adjustment is made with the adjusting screw after releasing the lock nut.

Rotate the crankshaft so that the piston of the cylinder to be adjusted is at firing TDC. This is the case when the valves of the synchronous pistons are just rocking.

Valve rocking on cylinder

1	5	3	6	2	4
6	2	4	1	5	3

Adjust valves on cylinder

In order to enable the engine to be rotated manually during adjustments, there is a plate with a central hexagon driver fitted to the front of the crankshaft pulley (bar-ring device).

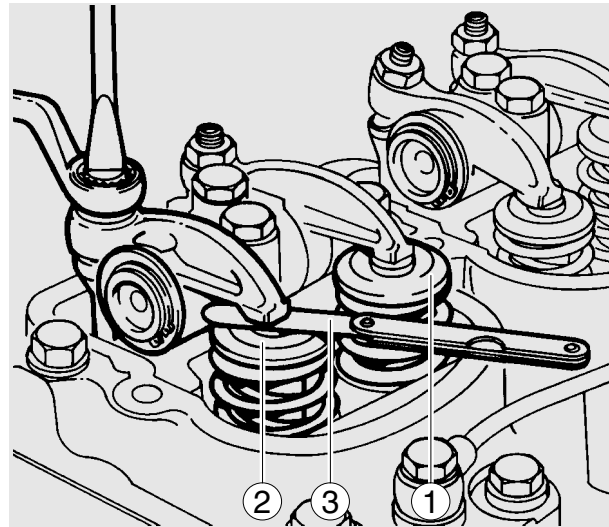

- 1 Inlet valve
- 2 Exhaust valve
- 3 Feeler gauge

Cylinder head bolts

General notes

The engine may have either of the following two types of cylinder head bolt:

- Cylinder head bolts with hex head tightened by the angle-of-rotation method, socket size 19
- Cylinder head bolts with Torx head tightened by the angle-of-rotation method, Torx wrench size E18

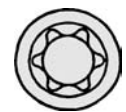

Bolts to be used in event of repairs:

Bolts with hex head may be replaced by bolts with Torx head if all the bolts on the engine are to be changed.

Do not use bolts with hex head and bolts with Torx head on the same engine.

Retightening cylinder head bolts on new engines (engine cold or warm)

by authorized specialist personnel

The cylinder heads are mounted with cylinder head bolts which are tightened by the angle-of-rotation method. On new engines the cylinder head bolts are tightened up for the first time at the factory after the engine has been broken in. The sticker “**First retightening of cylinder head bolts ...**” is then attached to one of the cylinder head covers.

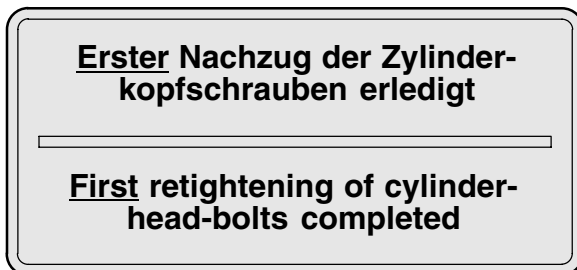

Spare part No. 51.97801–0211

After the first 400 hours of operation retighten cylinder head bolts 1 to 4 in the order shown in Tightening diagram “1” by a further 90° (1/4 revolution).

The two outer screws (intake and exhaust sides) must not be retightened.

Note:

The cylinder head bolts to be retightened must not be loosened first, but simply tightened by a further 90° (1/4 revolution) from their actual position.

Remove the sticker “**First retightening of cylinder head bolts ...**” and attach the sticker “**Second retightening of cylinder head bolts ...**” to show that the cylinder head bolts have been retightened for the second time.

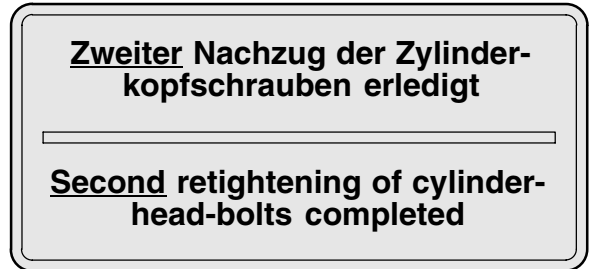

Spare part No. 51.97801–0212

Intake side / injector

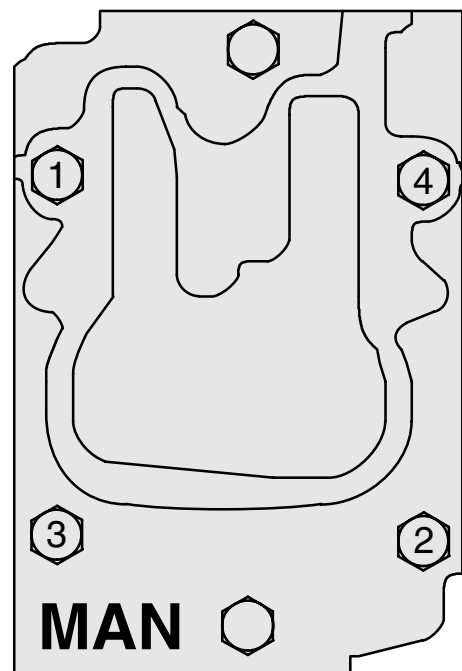

Exhaust side

Tightening diagram “1”

Tightening cylinder head bolts after a repair (engine cold)

by authorized specialist personnel

Before inserting the cylinder head bolts oil them with engine oil on the thread (not to the bore) and coat the contact face of the bolt head with "Optimoly White T" assembly paste. Do not use any oils or oil additives that contain MoS₂. The bolts must be tightened by the angle-of-rotation method as shown in Tightening diagram "2".

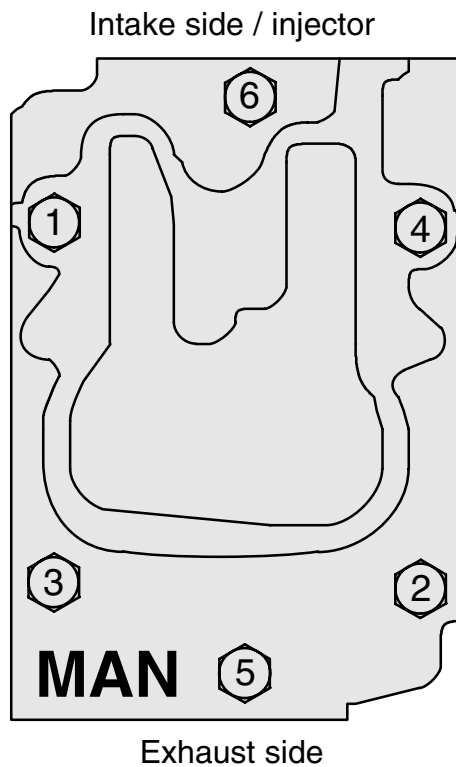

Tightening diagram "2"

- 1st pretightening step = to 10 Nm
- 2nd pretightening step = to 80 Nm
- 3rd pretightening step = to 150 Nm
- 4th pretightening step = turn by 90°
- Final tightening = turn by 90°

Adjust valve clearance

Retightening cylinder head bolts after repairs (engine cold or warm)

by authorized specialist personnel

After the first 10 to 20 hours of operation after a repair turn the cylinder head bolts by a further 90° (1/4 revolution) in the order shown in Tightening diagram "2".

The cylinder head bolts to be retightened must not be loosened first, but simply tightened by a further 90° (1/4 revolution) from their actual position.

Attach the sticker "**First retightening of cylinder head bolts ...**" (Remove any other stickers which may already be attached).

After the first 400 hours of operation after a repair tighten cylinder head bolts 1 to 4 in the order shown in Tightening diagram "1" again by a further 90° (1/4 revolution).

The two outside screws (intake and exhaust side) must not be retightened.

Attach the sticker "**Second retightening of cylinder head bolts ...**".

Note:

When a cylinder head has been removed the cylinder head gasket must always be changed.

Re-using old cylinder head bolts

Checking

Before re-using old cylinder head bolts check them as follows:

Length

During tightening the bolts are intentionally stressed beyond the yield point and therefore subjected to some permanent elongation each time they are tightened.

The shank lengths "L" of new bolts are 109, 144 and 168 mm.

Permissible maximum lengths are 111, 146 and 170 mm respectively.

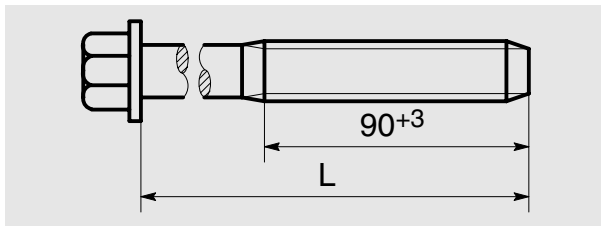

L = Shank length

Surface

The surface of the bolts must be in satisfactory condition, i.e. the phosphate coating must be intact and there must be no rust.

Rusted or damaged bolts or bolts elongated beyond the maximum permissible length must immediately be made unusable – e.g. by destroying the threads with a hammer – and scrapped.

V-belts

The tension of the V-belts should be checked after every 200 hours of operation.

Change the V-belts if necessary

If, in the case of a multiple belt drive, wear or differing tensions are found, always replace the complete set of belts.

Checking condition

Check V-belts for cracks, oil, overheating and wear.
Change damaged V-belts.

Testing by hand

A more precise check of the V-belt tension is possible only by using a V-belt tension tester.

Check with V-belt tension tester

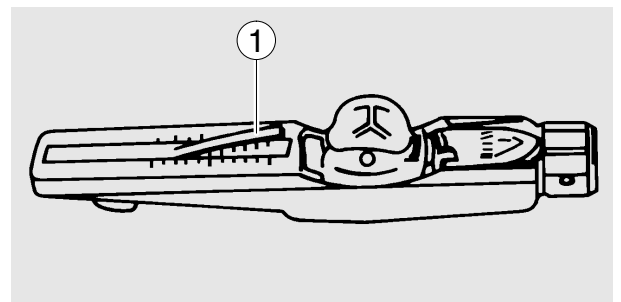

Measuring tension

- Lower indicator arm ① into the scale
- Apply tester to belt at a point midway between two pulleys so that edge of contact surface ② is flush with the V-belt

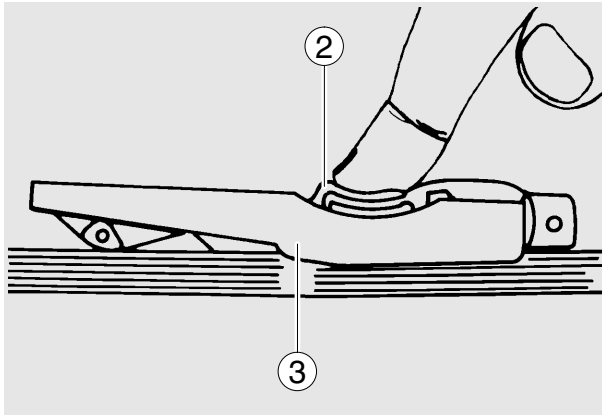

- Slowly depress pad ③ until the spring can be heard to disengage. This will cause the indicator to move upwards

If pressure is maintained after the spring has disengaged a false reading will be obtained!

Reading of tension

- Read of the tensioning force of the belt at the point where the top surface of the indicator arm ① intersects with the scale
- Before taking readings make ensure that the indicator arm remains in its position

Drive belt width	Tensioning forces according to the kg graduation on the tester		
	New installation		When servicing after long running time
	Installation	After 10 min. running time	
9.5	45–50	40–45	30
10.0	45–50	35–40	30
12.5	50–55	45–50	35
13.0	50–55	40–45	35
20.0	75	70	60
22.0	75	70	60
2/3VX	90–100	70–80	60
3/3VX	135–150	105–120	90

Tension and / or replace V-belts

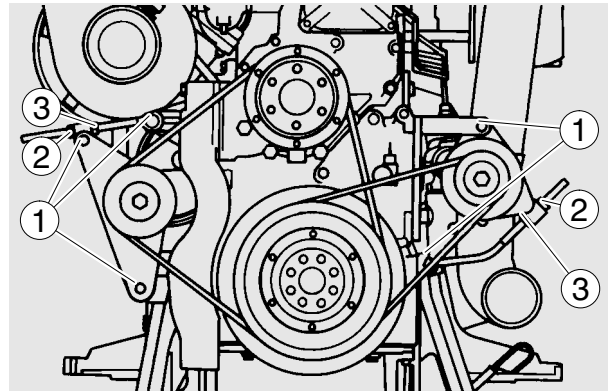

Water pump – Alternator

- Remove fixing bolts ①
- Remove lock-nut ②
- Adjust nut ③ until V-belts have correct tensions
- Retighten lock-nut and fixing bolts

To replace the V-belts loosen lock-nut and swing alternator inwards.



A series of horizontal dotted lines for writing notes.



Technical data

Model	D 2866 E
Design	in-line vertical
Cycle	4-stroke Diesel
Combustion system	Direct injection
Number of cylinders	6
Bore	128 mm
Stroke	155 mm
Swept volume	11 967 cm ³
Compression ratio	17.5 : 1
Rating	see engine nameplate
Firing order	1-5-3-6-2-4
Valve clearance (cold engine)	
Intake	0.25 mm
Exhaust	0.40 mm
Valve timing	
Intake opens	11° before TDC
Intake closes	49° after BDC
Exhaust opens	47° before BDC
Exhaust closes	9° after TDC
Fuel system	
Injection	In-line pump, with flange fastening
Governor	All speed type
Injection timer	Automatic centrifugal type in camshaft drive gear
Injectors	4-orifice nozzles
Opening pressure of injector	
New nozzle holder:	265 + 8 bar
Used nozzle holder:	250 + 8 bar
Start of delivery ± 1° crank angle before TDC (Speed constant = without timing adjustment)	
1500 rpm, constant	22°
1800 rpm, constant	24°
1500 rpm, variable	17°
1800 rpm, variable	17°
2100 rpm, variable	17°
2200 rpm, variable	17°

Technical data



Engine lubrication	Force feed	
Oil capacity in oil sump (litres)	min.	max.
Deep	12 l	18 l
Shallow	14 l	20 l
For 30° tilt	12 l	18 l
Oil pressure during operation (depending on oil temperature, oil viscosity class and engine rpm)	monitored by oil pressure monitors or displays	
Oil filter	Full flow filter with two paper cartridges	
Engine cooling system	Liquid cooling	
Operating temperature	80–85°C, temporarily 90°C allowed	
Electrical equipment		
Starter	24 V; 5.4 kW or 6.5 kW	
Alternator	28 V; 35, 55 or 120 A	



Technical data

Model	D 2866 TE
Design	in-line vertical
Cycle	4-stroke Diesel with turbocharger
Combustion system	Direct injection
Turbocharging	Turbocharger
Number of cylinders	6
Bore	128 mm
Stroke	155 mm
Swept volume	11 967 cm ³
Compression ratio	15.5 : 1
Rating	see engine nameplate
Firing order	1-5-3-6-2-4
Valve clearance (cold engine)	
Intake	0.50 mm
Exhaust	0.50 mm
Valve timing	
Intake opens	23° before TDC
Intake closes	37° after BDC
Exhaust opens	60° before BDC
Exhaust closes	30° after TDC
Fuel system	
Injection	In-line pump, with flange fastening
Governor	All speed type
Injection timer	Automatic centrifugal type in camshaft drive gear
Injectors	4-orifice nozzles
Opening pressure of injector	
New nozzle holder:	220 + 8 bar
Used nozzle holder:	220 + 8 bar
Start of delivery $\pm 1^\circ$ crank angle before TDC (Speed constant = without timing adjustment)	
1500 rpm, constant	24°
1800 rpm, constant	26°
1800 rpm, variable	19°
2100 rpm, variable	19°
2200 rpm, variable	19°

Technical data



Engine lubrication	Force feed	
Oil capacity in oil sump (litres)	min.	max.
Deep	12 l	18 l
Shallow	14 l	20 l
For 30° tilt	12 l	18 l
Oil pressure during operation (depending on oil temperature, oil viscosity class and engine rpm)	monitored by oil pressure monitors or displays	
Oil filter	Full flow filter with two paper cartridges	
Engine cooling system	Liquid cooling	
Operating temperature	80–85°C, temporarily 90°C allowed	
Electrical equipment		
Starter	24 V; 5.4 kW or 6.5 kW	
Alternator	28 V; 35, 55 or 120 A	



Technical data

Model	D 2866 LE, LXE
Design	in-line vertical
Cycle	4-stroke Diesel with turbocharger and intercooler
Combustion system	Direct injection
Turbocharging	Turbocharger with intercooler
Number of cylinders	6
Bore	128 mm
Stroke	155 mm
Swept volume	11 967 cm ³
Compression ratio	
D 2866 LE	15.5 : 1
D 2866 LXE	16 : 1
Rating	see engine nameplate
Firing order	1-5-3-6-2-4
Valve clearance (cold engine)	
Intake	0.25 mm
Exhaust	0.40 mm
Valve clearance changed	
Starting from engine no ...5264038.... (in engines with 2-cylinder air compressors and / or power take-off starting from engine no ...5274086....) (D 2866 LE only)	
Intake	0.50 mm
Exhaust	0.50 mm
See instruction label on valve cover	
Valve timing D 2866 LE	
Intake opens	23° before TDC
Intake closes	37° after BDC
Exhaust opens	60° before BDC
Exhaust closes	30° after TDC
Valve timing D 2866 LXE	
Intake opens	23° before TDC
Intake closes	12° after BDC
Exhaust opens	60° before BDC
Exhaust closes	30° after TDC
Fuel system	
Injection	In-line pump, with flange fastening
Governor	All speed type

Injection timer	Automatic centrifugal type in camshaft drive gear			
Injectors	4-orifice nozzles			
Opening pressure of injector				
Injector + injection nozzle	New nozzle holder:	Used nozzle holder:		
51.10101-7274	220 + 8 bar	220 + 8 bar		
51.10101-7290	235 + 8 bar	220 + 8 bar		
51.10101-7338	295 + 8 bar	280 + 8 bar		
Start of delivery $\pm 1^\circ$ crank angle before TDC (Speed constant = without timing adjustment)		Injection pump		
		Exhaust manifold		
		dry	liquid-cooled	
	1500 rpm, constant		23°	20°
	1500 rpm, constant (LXE)		15°	–
	1800 rpm, constant		25°	22°
	1800 rpm, constant (LXE)		16°	–
	1800 rpm, variable	51.11102–7659	–	15°
	1800 rpm, variable	51.11103–7075	–	18°
	2100 rpm, variable	51.11102–7657	–	15°
	2100 rpm, variable	51.11103–7084	–	20°
	2200 rpm, variable	51.11102–7656	–	15°
	2200 rpm, variable	51.11103–7072	–	21°
2200 rpm, variable (LXE)	51.11102–7993	–	15°	
2200 rpm, variable (LXE)	51.11103–7071	–	21°	
Engine lubrication	Force feed			
Oil capacity in oil sump (litres)	min.	max.		
Deep	12 l	18 l		
Shallow	14 l	20 l		
For 30° tilt	12 l	18 l		
Oil pressure during operation (depending on oil temperature, oil viscosity class and engine rpm)	monitored by oil pressure monitors or displays			
Oil filter	Full flow filter with two paper cartridges			
Engine cooling system	Liquid cooling			
Operating temperature	80–85°C, temporarily 90°C allowed			
Electrical equipment				
Starter	24 V; 5.4 kW or 6.5 kW			
Alternator	28 V; 35, 55 or 120 A			

A		N	
Air cleaner	22, 41–43	Nameplates	4
Alternator	23, 26		
C		O	
Checking and setting	44–52	Oil cooler	19
Commissioning and operation	24–26	Oil drainage	27
Cooling	22, 35–38	Oil level	27
Cooling circuit		P	
Cleaning outside of radiator	36	Piston / Conrod / Crank assembly	16
Cleaning the inside of tube bundles of raw water heat exchangers	37	Preparations	24
Descaling	37	R	
Filler caps and working valves	38	Raw water pump	25
Internal cleaning	36	Refilling with oil	27
Cylinder head bolts	48–51	Running in	25
D		S	
Declaration	3	Safety regulations	5–9
Draining of coolant	35	Safety regulations: Summary	
During operation	25	Handling parts containing asbestos	9
E		Handling used engine oil	8
Electrical equipment	23	Preventing accidents with injury to persons	5
Engine block	16	Preventing damage to engine and premature wear	7
Engine lubrication	18, 27	Preventing environmental damage	8
Engine timing	17	Shutting down	26
Engine views	10–15	Sources of supply for pickling fluids	38
Engines	16	Starter motor	23
F		Starting	25
Filling-in of coolant	35	Strainer	29
Fuel filters	21, 29–32	T	
Fuel lift pump	29	Technical data	54–59
Fuel system	20, 29–34	Technical information	10–23
I		Temporary decommissioning	26
Injection pump	20, 29	To check and adjust valve clearance	48
Injector maintenance	33	To check and set the start of delivery	44–48
Intercooler	22, 40	Turbocharger	21, 39
L		V	
Lubricating oil filter	27	V-belts	51
M		Valves	17
Maintenance and care	27–43	W	
Marking the dipstick	24	Waste water treatment	38



MAN Nutzfahrzeuge Aktiengesellschaft

**Vogelweiherstraße 33
D-90441 Nürnberg**



Printed in Germany

51.99493-8264