

**Indian Maritime University**  
**(A Central University, Govt of India)**  
**End Semester Examinations – December 2023**  
**Programme Name: B. Tech (Marine Engineering)**  
**Semester: I**  
**Subject Code: UG11T4102**  
**Subject Name: PHYSICS**

Date: 18.12.2023

Max Marks: 70

Duration: 03 Hrs

Pass Marks: 35

General Instructions

- (i) All Sections (A, B & C) are to be attempted.
- (ii) Options, if any, are specified in respective section.

**Section A**

**Ten MCQs/Fill in the Blanks of 01 Mark each – Choose the correct answer as applicable.**

1. Coulomb's law is valid for .....
  - (a) Only point charge
  - (b) for both point charge and distributed charge
  - (c) Only distributed charges
  - (d) Neither distributed nor point charge
2. Appliances based on heating effect of electric current work on
  - (a) DC only
  - (b) AC only
  - (c) Both AC & DC
  - (d) None of the above
3. For any medium , electric flux density D is related to electric intensity E by the equation
  - (a)  $D = \epsilon_0 E$
  - (b)  $D = \epsilon_0 \epsilon_r E$
  - (c)  $D = E / \epsilon_0 \epsilon_r$
  - (d)  $D = \epsilon_0 E / \epsilon_r$

4. The direction of induced e.m.f can be found by
- (a) Laplace law
  - (b) Lenz law
  - (c) Fleming's right hand rule
  - (d) Kirchhoff's voltage law
5. An electric fan and a heater are marked 100 W, 220 V and 1000 W, 220 V respectively. The resistance of the heater is
- (a) zero
  - (b) greater than that of fan
  - (c) less than that of fan
  - (d) equal to that of fan
6. A free-body diagram is
- (a) It's a sketch of a moving body that shows internal forces of the body and reaction forces
  - (b) It's a sketch of an undisturbed body that shows external forces of the body
  - (c) It's a sketch of an isolated body that shows external forces of the body and reaction forces
  - (d) It's a sketch of a body in motion that shows bending forces of the body
7. According to law of triangle of forces
- (a) Three forces acting at a point will be in equilibrium
  - (b) Three forces acting at a point can be represented by a triangle, each side being proportional to respective force
  - (c) If three forces acting at a point are in equilibrium, each force is proportional to the sine of the angle between the other two
  - (d) If three forces acting upon a particle are represented in magnitude and direction by the sides of a triangle, taken in order, they will be in equilibrium
8. Couple is formed due to two \_\_\_\_\_
- (a) like, parallel and non-collinear forces of same magnitude
  - (b) like, perpendicular and collinear forces of different magnitude
  - (c) unlike, parallel and non-collinear forces of same magnitude
  - (d) unlike, perpendicular and non-collinear forces of different magnitude

9. The force of friction between two bodies in contact
- (a) Is always normal to the surface of their contact
  - (b) Depends upon the relative velocity between them
  - (c) Depends upon the area of their contact
  - (d) All of the above
10. If a body is in equilibrium. We may conclude that
- (a) No force is acting on the body
  - (b) The resultant of all the forces acting on it is zero
  - (c) The moments of the forces about any point is zero
  - (d) Both (b) and (c)

### **Section B**

#### **Five Questions of 02 Marks each**

11. Two forces of 100 N and 150 N are acting simultaneously at a point. What is the resultant of these two forces, if the angle between them is  $45^\circ$ ?
12. What are magnetic field lines? Justify the following statements:
- (i) Two magnetic field lines never intersect each other.
  - (ii) Magnetic fields are closed curves.
13. Write a short note on electron drift velocity
14. State and explain Coulomb's law in electrostatics
15. Explain skin effect. List the factors that affect skin effect.

### **Section C**

#### **Seven Questions of 10 Marks each of which any 05 questions to be answered.**

16. a) Define coefficient of friction and angle of friction. Establish relation between them. Also show that angle of friction and angle of repose are equal. (06 marks)
- b) A mass of 4 kg rests on a horizontal plane. The plane is gradually inclined until at an angle  $\theta = 15^\circ$  with the horizontal, the mass just begins to slide. What is the coefficient of static friction between the block and the surface? (04 marks)

17. (a) Draw and explain B-H curve of a ferromagnetic material.  
 (b) Write the difference between self-inductance & mutual inductance.  
 (05 marks + 05 marks)
18. a) State & prove Law of parallelogram of forces (05 marks)  
 b) Two forces of 100 N and 150 N are acting simultaneously at a point.  
 Find the resultant if the angle between them is  $45^\circ$  (05 marks)
19. a) State and Explain Kirchoff's Law. (04 marks)  
 b) Find the unknown circuit parameters and power delivered by a 10 V battery for the simple parallel circuit shown below: (06 marks)

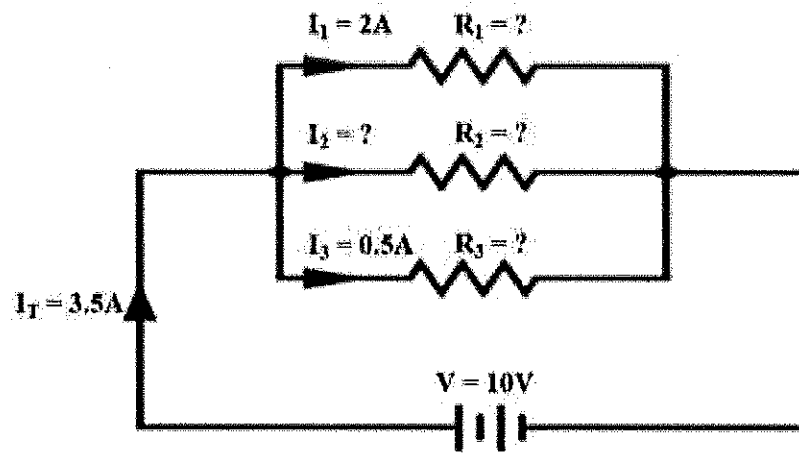

20. a) With necessary waveform explain lead and lag associated with an alternating quantity (05 marks)  
 b) An alternating current of frequency 60 Hz has a maximum value of 12 A.  
 (i) Write down the equation for instantaneous values.  
 (ii) Find the value of the current after  $1/360$  seconds.  
 (iii) Find the time taken to reach 9.6 A for the first time.  
 (05 marks)
21. Derive an expression for electric potential due to a point charge
22. a) State and prove Lami's theorem (06 marks)  
 b) What is Free body diagram? How to draw a free-body diagram?  
 (04 marks)