

TemPower

INSTRUCTION MANUAL FOR AIR CIRCUIT BREAKERS
(With Draw-out Cradle and Type AGR-21B, 22B Overcurrent Protective Device)



Types: AR208S
AR212S
AR216S
AR220S
AR325S
AR332S
AR440S
AR212H
AR216H
AR220H
AR316H
AR320H
AR325H
AR332H

Notice

- Be sure to read this manual before installing, operating, servicing, or inspecting the ACB.
- Please retain this manual for future reference.
- Electrical work must be done by competent persons.
- ACB maintenance, inspection, parts replacement, OCR field tests and setting changes must be performed by competent persons.

TERASAKI ELECTRIC CO., LTD.

TABLE OF CONTENTS

1. SAFETY NOTICES	5	5-3-4. Setup screen	48
2. RECEIVING AND HANDLING	7	5-3-5. Reset screen	50
2-1. Transportation Precautions	7	5-3-6. Setting 1 screen	51
2-1-1. Transporting the ACB	7	5-3-7. Setting 2 screen	53
2-1-2. Transporting the breaker body	8	5-3-8. Maintenance screen	56
2-1-3. Transporting the draw-out cradle	8	5-4. OCR Function Check	57
2-2. Storage Precautions	8	5-5. Operation Indication and Indication Resetting Procedure	59
2-3. Installation Precautions	9	6. MAINTENANCE, INSPECTION AND PARTS REPLACEMENT	61
3. GENERAL	14	6-1. Inspection Procedures	62
3-1. Types and Descriptions	14	6-2. Parts Replacement Procedure	65
3-2. Parts and Functions	17	6-2-1. Preparation	65
3-3. Circuits and Ratings	20	6-2-2. Arc chambers	68
4. OPERATION	25	6-2-3. Stationary contact	69
4-1. Charging and Opening operation	25	6-2-4. Moving contact	71
4-1-1. Charging operation	25	6-2-5. Latch release coil (LRC)	73
4-1-2. Closing operation	26	6-2-6. Shunt trip device (SHI)	74
4-1-3. Opening operation	26	6-2-7. Control relay	75
4-1-4. Motion of trip indication and spring charge indication switches	26	6-2-8. Magnet hold trigger (MHT)	78
4-1-5. Motion of operation mechanisms	27	6-2-9. Auxiliary switches	79
4-2. Draw-out and Insertion Operation	29	7. TROUBLESHOOTING FLOWCHARTS	81
4-2-1. General	29		
4-2-2. Draw-out operation	30		
4-2-3. Putting the breaker body back into the draw-out cradle	31		
4-2-4. Contact status of auxiliary and position switches	33		
4-3. ON-OFF Button Cover Locking Procedure	33		
4-4. Lock in OFF Procedure	34		
4-5. Position Lock Lever Locking Procedure	34		
4-6. Breaker Fixing Bolt Securing Procedure	35		
4-7. OCR Cover Locking Procedure	35		
5. OVERCURRENT RELEASE (OCR)	36		
5-1. Specifications	36		
5-2. Characteristics	37		
5-2-1. L characteristic for general feeder	37		
5-2-2. R characteristic for general feeder	39		
5-2-3. S characteristic for generator protection	43		
5-3. How to display measurements and make settings	45		
5-3-1. General	45		
5-3-2. Available screens	46		
5-3-3. Monitor screen	47		

1. SAFETY NOTICES

Thank you for purchasing the TERASAKI AR-series Air Circuit Breaker (TemPower2).

This chapter contains important safety information.

Be sure to carefully read these safety notices, instruction in this manual, and other documents accompanying the Air Circuit Breaker (hereinafter referred to as the ACB) to familiarize yourself with safe and correct procedures or practices before installing, operating, or servicing the ACB.

In this manual, safety notices are divided into “DANGER” and “CAUTION” according to the hazard level:

 **DANGER** : A danger notice with this symbol indicates a potentially hazardous situation which, if not avoided, could result in death or serious injury.

 **CAUTION** : A caution notice with this symbol indicates a potentially hazardous situation which, if not avoided, may result in minor or moderate injury and/or property damage.

Note that failure to observe a caution notice could result in serious injury/damage in some situations. Because safety notices contain important information, be sure to read and observe them.

■ Transportation Pre caution

DANGER

- Never stand under the ACB that has been lifted or suspended by a lifter or lifting attachments. The weight of the ACB may cause serious injury.

■ Installation Pre cautions

CAUTION

- Electrical work must be done by competent persons.
- Do not place the ACB in such an area that is subject to high temperatures, high humidity, dusty air, corrosive gases, strong vibration and shock, or other unusual conditions. Mounting the ACB in such an area could cause a fire or malfunction.
- Be careful to prevent foreign objects (such as debris, concrete powder, dust, chippings, and iron powder) and oil or rainwater from entering the ACB. These materials inside the ACB could cause a fire or malfunction.
- Prior to commencing any work on the ACB, open an upstream circuit breaker or the like to isolate all sources of power/voltage. Otherwise, electric shock may result.
- Fix the draw-out cradle of the ACB firmly on a flat, level surface using mounting screws. Otherwise, the draw-out operation may cause the breaker body or the draw-out cradle to fall, resulting in damage to the ACB or personal injury.
- Take care not to deform or bend protrusions in the bottom face of the draw-out cradle when fixing the draw-out cradle with mounting screws. Deformation of the protrusions may cause a malfunction.
- Connect conductors (including screws) to the main circuit terminals in the specified area. Otherwise, a short-circuit may result.
- When terminating conductors to the ACB, tighten terminal screws to the torque specified in this manual. Otherwise, a fire could result.
- For 4-pole ACBs, be sure to connect a 3-phase, 4-wire neutral conductor to the N-phase pole (on the right end). Otherwise, an overcurrent may hinder the ACB from tripping, resulting in a fire.

■ Operation Pre cautions

DANGER

- Never touch live terminal parts. Doing so will result in electric shock.
- Do not leave the ACB body in the draw-out position. If the ACB body is accidentally dropped, its weight may cause serious injury.

CAUTION

- Do not force down the charging handle after completion of manual charging operation. Doing so may cause a malfunction.
- The permissible operating voltage of the spring charging motor is 85 to 110% of the rated ac voltage or 75 to 110% of the rated dc voltage. Be sure to supply a voltage within the above ranges to the motor. Otherwise, a malfunction, burnout, or fire may result.

■ Operation Precautions (continued)

⚠ CAUTION

- Repeated open/close operation by the motor charging mechanism without pause should not exceed 15 times. If repeated continuous open/close operation is inevitable, a pause of at least 20 minutes should be provided after the repetitions of 15 times. Otherwise, a spring charging motor may be burnt out.
- Do not bring your hand or face close to arc gas vent of the arc chamber while the ACB is closed. Otherwise, a burn may result from high-temperature arc gas blowing out of the arc gas vent when the ACB trips open.
- If the ACB trips open automatically, remove the cause of tripping operation before re-closing the ACB. Otherwise, a fire could result.
- If the ACB has the breaker fixing bolts, be sure to loose the fixing bolts before draw-out operation. Otherwise, damage to the ACB may result.
- Make sure the draw-out cradle is secured with mounting screws before inserting or drawing out the breaker body. Otherwise, the insertion or draw-out operation may cause the breaker body or the draw-out cradle to fall, resulting in damage to the ACB or personal injury.
- When retracting the draw-out rail into the draw-out cradle, be sure to push the rail end. Do not hold the hook pin, body stopper, or body stopper shaft. Doing so may cause your fingers to be pinched, resulting in injury.
- Do not forcibly turn the draw-out handle clockwise when the breaker body is in the "CONN." position. Doing so may cause a malfunction.
- If the ACB has the breaker fixing bolts, make sure the bolts on both sides are securely tightened before using the ACB. Loosened fixing bolts may cause a malfunction of the ACB, in particular when it is installed in such an area that is subject to strong vibrations.

■ OCR (Overcurrent Release) Handling Precautions

⚠ CAUTION

- OCR field tests and setting changes must be performed by competent persons.
- After completion of OCR tests, be sure to return the settings to the original values. Failure to do so may cause a fire or burnout.

■ Maintenance and Inspection Precautions

⚠ CAUTION

- ACB maintenance, inspection and parts replacement must be performed by competent persons.
- Do not touch ACB current carrying parts and ACB structural parts close to a current carrying part immediately after the ACB trips open. Remaining heat may cause a burn.
- Prior to commencing any work on the ACB, open an upstream circuit breaker or the like to isolate all sources of power/voltage from the main and control circuits. Otherwise, electric shock may result.
- Take care to avoid adhesion of dust to main and control circuit contacts. Dust on the contacts may result in a fire.
- Prior to commencing maintenance, inspection, or parts replacement, make sure that the closing springs are released and the ACB is open. Otherwise, unintentional open/close operation may lead to fingers or tools to be pinched by the open/close mechanism, resulting in injury.
- Retighten the terminal screws periodically to the specified torque. Otherwise, a fire could result.
- When grinding a contact tip, be careful to prevent grinding dust from entering the breaker operating mechanism. Wipe the tip clean after grinding. Otherwise, a malfunction or fire could result.
- Do not perform dielectric withstand tests under other conditions than specified. Doing so may cause a malfunction.
- Be sure to reinstall the arc chamber if removed. Failure to do so or incorrect installation of the arc chamber may result in a fire or burn.
- When charging the closing springs or performing open/close operation of the ACB with the arc chamber, front cover and/or side covers removed during maintenance or inspection work, do not touch parts other than those required for the above operation (charging handle, ON/OFF buttons, moving core and the like). Doing so may cause fingers or tools to be pinched, resulting in injury.
- When replacing an auxiliary, do not damage the control wire for the auxiliary or pinch the wire between the auxiliary and the breaker body. Doing so may cause a malfunction.

2. RECEIVING AND HANDLING

Upon receipt of your ACB, check the following. If you have any question or problem, contact us at the indicated on the back cover of this manual.

- Check that the ACB received is as ordered and that the accessories are as specified.
- Check that the ACB is not damaged during shipment.

2-1. Transportation Precautions

⚠ DANGER

- Never stand under the ACB that has been lifted or suspended by a lifter or lifting attachments. If the ACB body is accidentally dropped, its weight may cause serious injury.

2-1-1. Transporting the ACB

- Before transporting the ACB, make sure the breaker body is in the CONN. position. If the ACB has breaker fixing bolts, make sure the breaker body is secured to the draw-out cradle with the fixing bolts.
- When lifting the ACB, hold it using lifting attachments or wire ropes through the lifting holes. Take care that the position switches, control circuit terminals, auxiliary switches, arc gas barrier and control terminal block cover which are shown in Fig. 1 are not damaged by the lifting rope. Lift the ACB carefully and gently. For transportation, place the ACB on a pallet and carry slowly and carefully.
- Avoid shock and vibration to the ACB during transportation.
- Do not lay the ACB during transportation.
- When transporting the ACB over great distances, crate it for protection against shock and vibration and secure the crate package with wood or ropes.
- When transporting the ACB while it is installed in a switchboard, you should fix the breaker body in the draw-out cradle with the breaker fixing bolts (optional).
- Lower the ACB onto a flat, level surface.

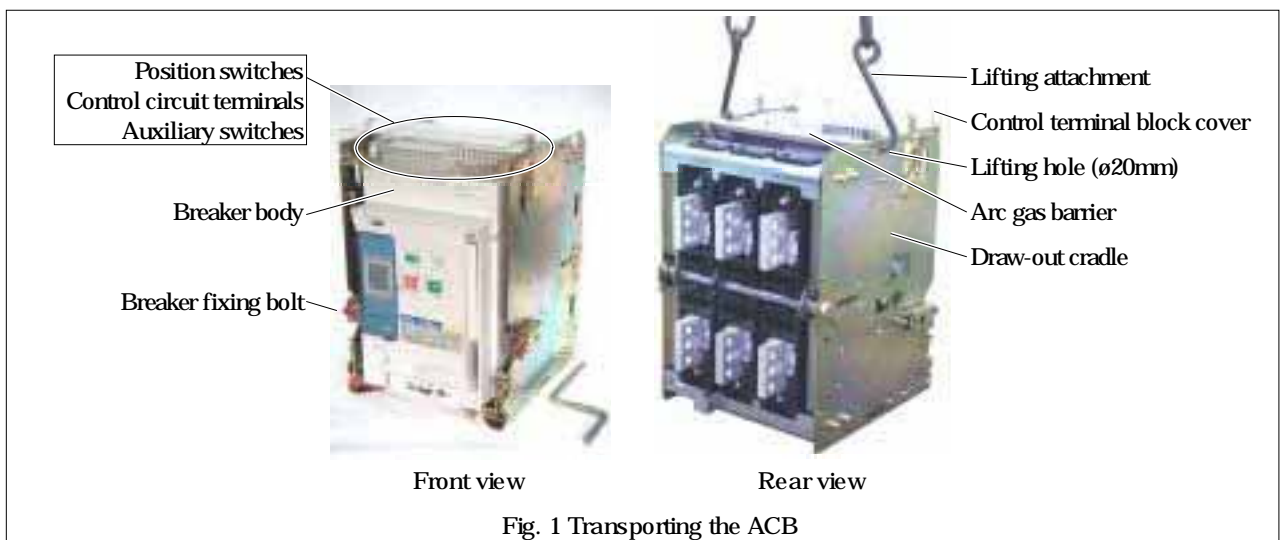
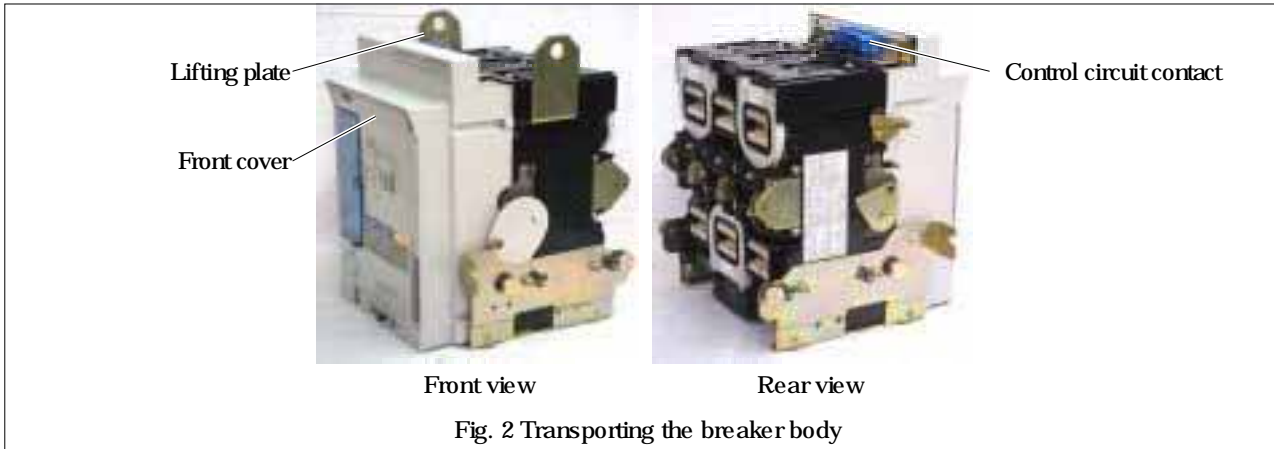

Fig. 1 Transporting the ACB

2-1-2. Transporting the breaker body

- Use an optional lifter or lifting plate to transfer the breaker body.
- When transporting the breaker body on a lifter, move the lifter with the lifter fork held at the lowest possible position.
- Take care not to exert forces on the front cover and the control circuit contacts shown in Fig. 2 . Otherwise, a deformation or damage may result.



2-1-3. Transporting the draw-out cradle

- When transporting the draw-out cradle, hold it using lifting attachments or wire ropes through the lifting holes or carry it by the portions (4 points) marked with the arrows shown in Fig 3. When carrying the draw-out cradle, take care not to exert forces on the arc gas barrier, the draw-out arm, the position switches, the auxiliary switches, the control circuit terminals, the control terminal block cover, and the control circuit contacts.

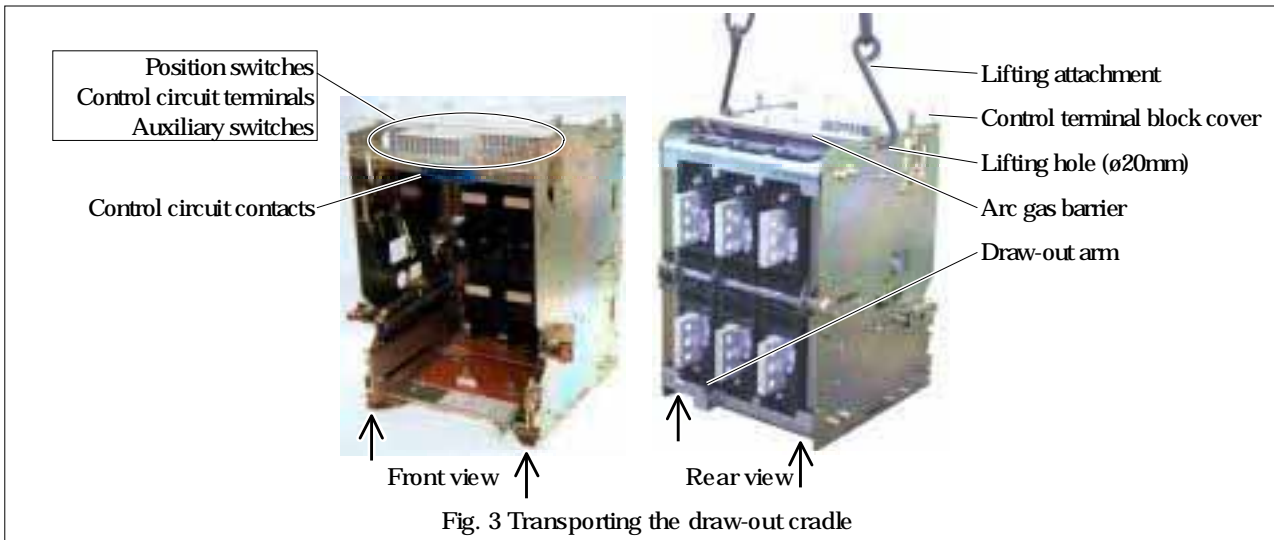

2-2. Storage Precautions

It is recommended that the ACB be used as soon as you have received it. If it is necessary to store the ACB, note the following:

- Store the ACB in a dry indoor location to prevent condensation due to sudden changes in ambient temperature. Condensation has a harmful effect on the ACB insulation.
- Store the ACB in a clean place free of corrosive gases and dust. In particular, exposure to a mixture of moisture and cement dust may cause corrosion damage to metal parts of the ACB.
- Place the ACB on a flat, level surface in its normal position (Do not lay the ACB).
- Do not place the ACB directly on the floor. Do not stack the ACBs during storage.

2-3. Installation Precautions

⚠ CAUTION

- Electrical work must be done by competent persons.
- Do not place the ACB in such an area that is subject to high temperatures, high humidity, dusty air, corrosive gases, strong vibration and shock, or other unusual conditions. Mounting the ACB in such an area could cause a fire or malfunction.
- Be careful to prevent foreign objects (such as debris, concrete powder, dust, chippings, and iron powder) and oil or rainwater from entering the ACB. These materials inside the ACB could cause a fire or malfunction.
- Prior to commencing any work on the ACB, open an upstream circuit breaker or the like to isolate all sources of power/voltage. Otherwise, electric shock may result.
- Fix the draw-out cradle of the ACB firmly on a flat, level surface using mounting screws. Otherwise, the draw-out operation may cause the breaker body or the draw-out cradle to fall, resulting in damage to the ACB or personal injury. Take care not to deform or bend protrusions in the bottom face of the draw-out cradle when fixing the draw-out cradle with mounting screws. Deformation of the protrusions may cause a malfunction.
- Connect conductors (including screws) to the main circuit terminals in the specified area. Otherwise, a short-circuit may result.
- When terminating conductors to the ACB, tighten terminal screws to the torque specified in this manual. Otherwise, a fire could result.
- For 4-pole ACBs, be sure to connect a 3-phase, 4-wire neutral conductor to the N-phase pole (on the right end). Otherwise, an overcurrent may hinder the ACB from tripping, resulting in a fire.

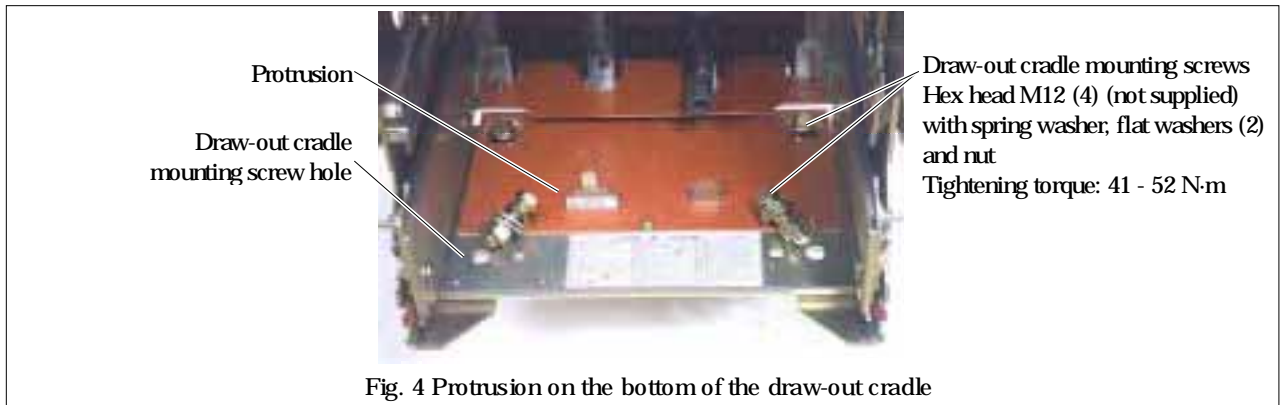

Fig. 4 Protrusion on the bottom of the draw-out cradle

- Do not install the ACB in such an area that is exposed to direct sunlight.
- Make sure that the mounting base has a sufficient capacity of bearing the weight of the ACB (see Table 3 and Table 4). The mounting base must be protected against vibration. Take appropriate measures to provide a perfect protection to the mounting base against resonance. Otherwise, open/close operation of the ACB may cause a malfunction of other devices in the switchboard or vibrations of the switchboard may cause a malfunction of the ACB.
- Use the following screws with appropriate length for the main circuit terminals.
Main circuit terminal screws: Hex head M10, with flat washers (2), spring washer (1) and nut (1) per screw
Tightening torque: 22.5 - 37.2 N·m

Table 1 Number of main circuit terminal screws required

ACB type		AR208S, AR212S, AR216S	AR220S, AR212H, AR216H, AR220H	AR325S, AR332S, AR316H, AR320H, AR325H, AR332H	AR440S
Number of main circuit terminal screws (3/4-pole)	Vertical terminals	12/16	18/24	24/32	48/64
	Horizontal/front terminals*	12/16		18/24	-

* Front terminals are not applicable for high-performance ARxxxH types.

- Use the following screw for the ground terminal. The screw must have a length that allows it to be inserted 4 - 9 mm into the ground terminal M8 tapped hole.
Ground terminal screw: M8 (1) with spring washer and flat washer
Tightening torque: 11.8 - 14.7 N·m

- Connect conductors to the main circuit terminals in the conductor connection area as shown in Figs. 5 - 7.

● Vertical terminals, 3 Poles

Right side view

Back view

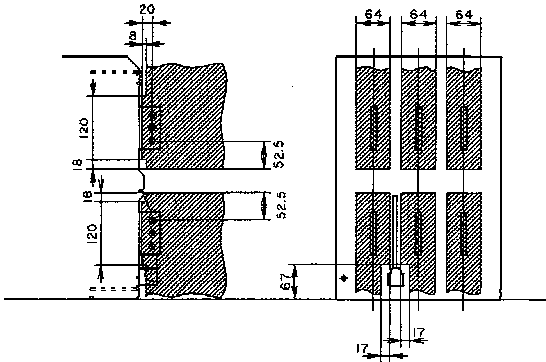

● Vertical terminals, 4 Poles

Right side view

Back view

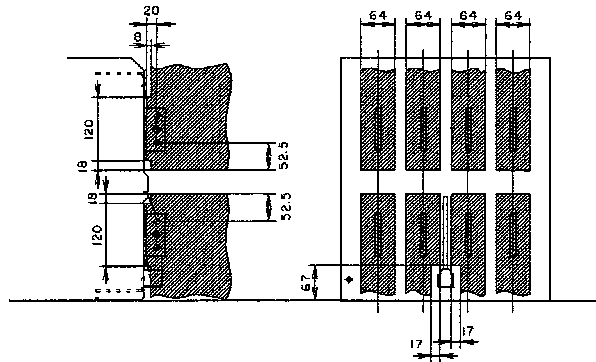

● Horizontal terminals, 3 Poles

Right side view

Back view

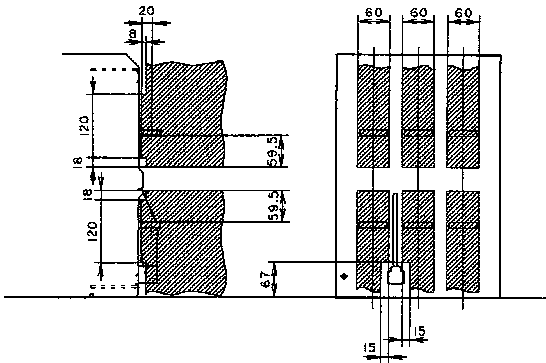

● Horizontal terminals, 4 Poles

Right side view

Back view

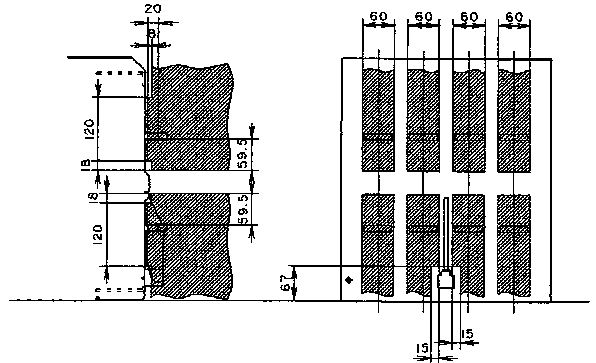

● Front terminals, 3 Poles

Right side view

Back view

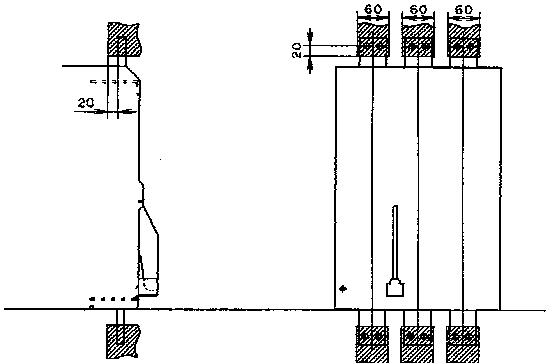

● Front terminals, 4 Poles

Right side view

Back view

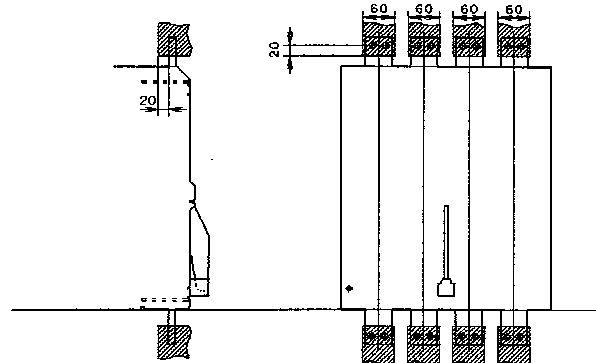
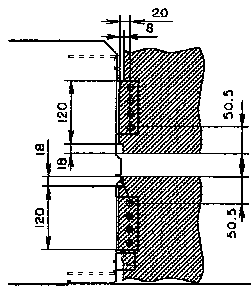

Fig. 5 Conductor (include screw) connection area (AR208S, AR212S, AR216S, AR220S, AR212H, AR220H)

● Vertical terminals, 3 Poles

Right side view



Back view

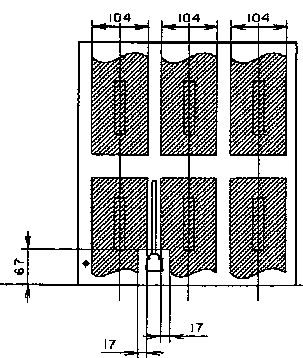

● Vertical terminals, 4 Poles

Right side view

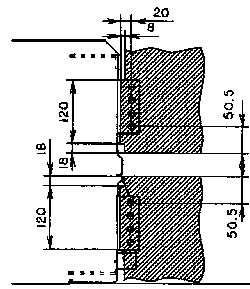

Back view

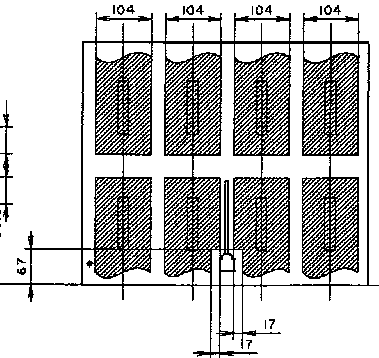

● Horizontal terminals, 3 Poles

Right side view

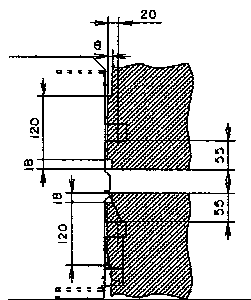

Back view

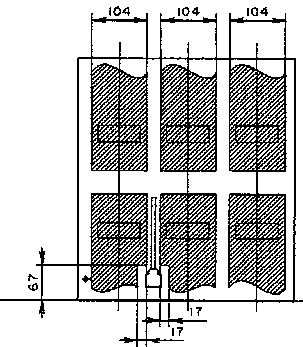

● Horizontal terminals, 4 Poles

Right side view

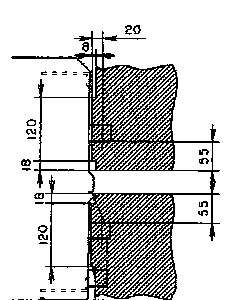

Back view

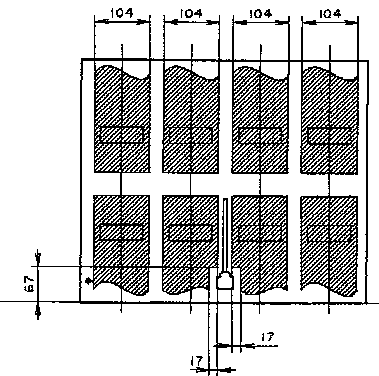

● Front terminals, 3 Poles

Right side view

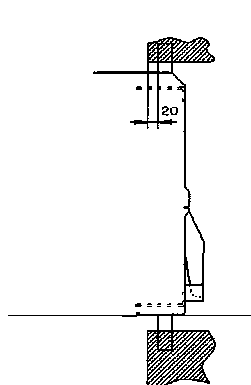

Back view

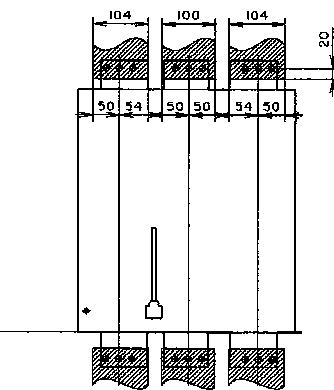

● Front terminals, 4 Poles

Right side view

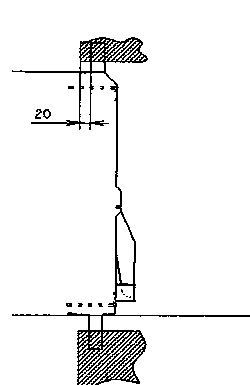

Back view

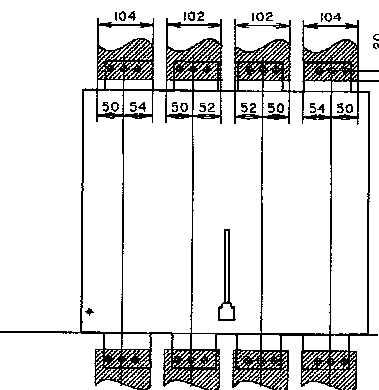
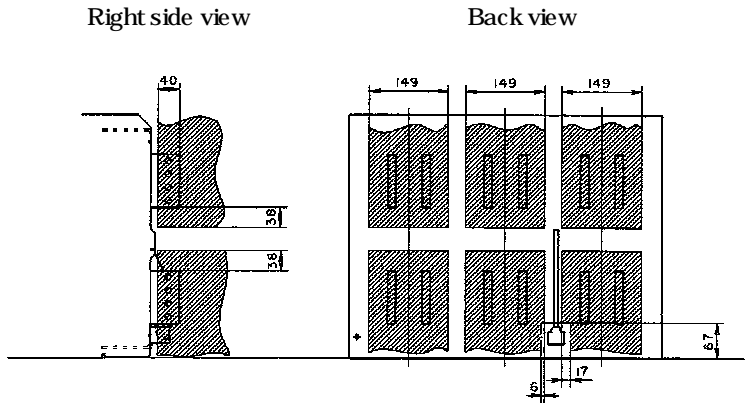

Fig. 6 Conductor (include screw) connection area (AR325S, AR332S, AR316H, AR320H, AR325H, AR332H)

● Vertical terminals, 3 Poles



● Vertical terminals, 4 Poles

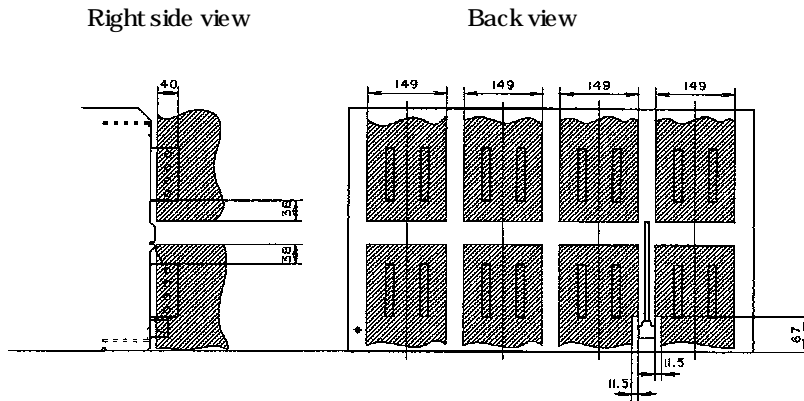

Fig. 7 Conductor (include screw) connection area (AR440S)

- Use a support to hold conductors securely at distance L as shown in Fig. 8 and Table 2. Such a support will help preventing the conductors and main circuit terminals from being deformed or damaged due to a large electromagnetic force caused by any fault current. Use a high-quality insulating material for a support and secure enough insulation distance.

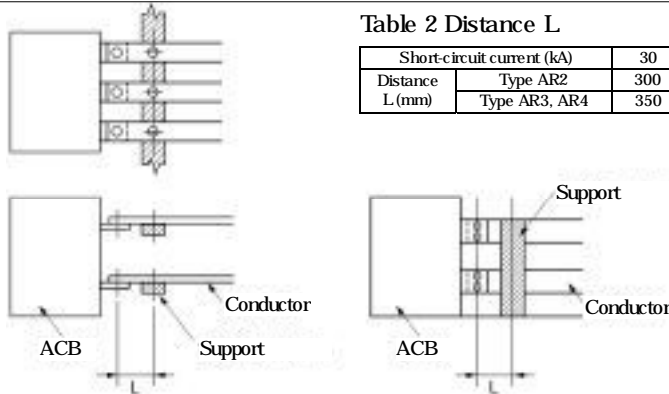
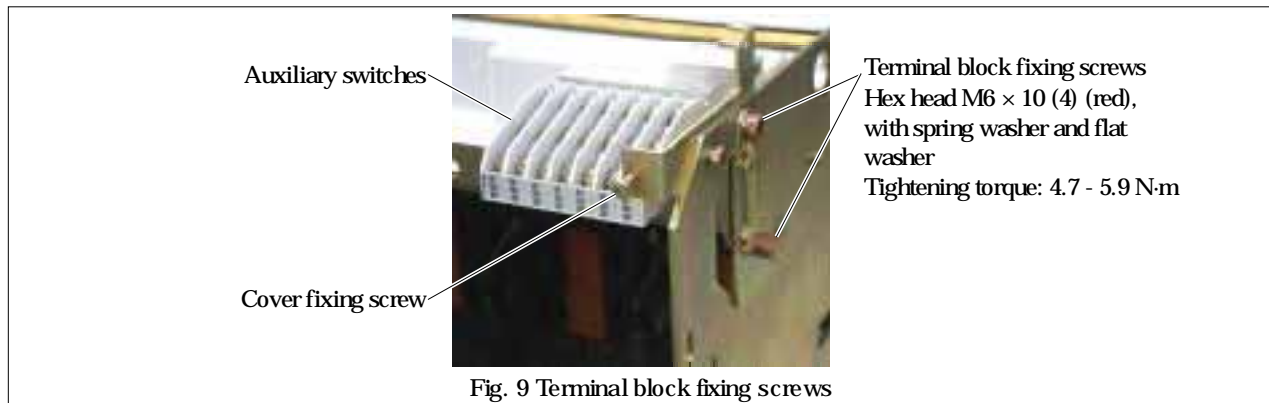

Table 2 Distance L

Short-circuit current (kA)		30	50	65	80	100
Distance L (mm)	Type AR2	300	250	150	150	-
	Type AR3, AR4	350	300	250	150	150

Fig. 8 Support mounting

- The following procedure makes it easy to make connections with plug-in tab terminals (#187) of position switches, control circuit terminals, and auxiliary switches.
- (1) Draw out the breaker body to the removed position, and remove it using an optional lifter or lifting plate. Refer to sections 4-2-2 and 2-1-2.
 - (2) If the ACB is equipped with the control terminal block cover, loosen both the cover fixing screws and remove the cover.
 - (3) Remove the terminal block fixing screws shown in Fig. 9.



- (4) Tilt the terminal block down as shown in Fig. 10. After connecting wires, tilt the terminal block up again and fix it with the terminal block fixing screws.

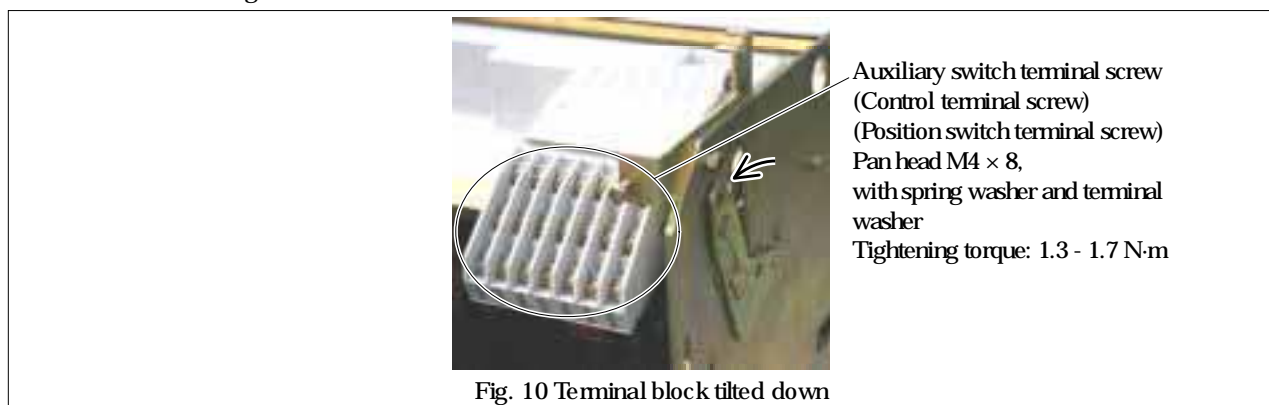

- Connect the control wire to a com. terminal as shown in Fig. 11.

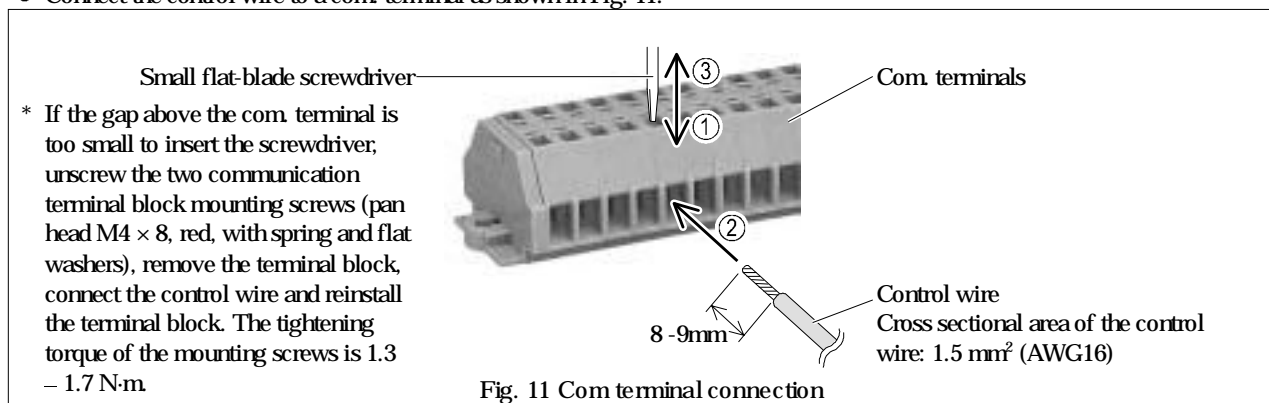



- If any work is done near the ACB that have been installed, protect the openings of the ACB with appropriate covers to prevent spatters, metal chips, wire cuttings or other foreign objects from entering the ACB.

3. GENERAL

3-1. Types and Descriptions

TemPower2 is available in types shown in Tables 3 and 4.

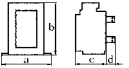
Table 3 Standard types

Frame size (A)	800		1250		1600		2000		2500		3200		4000			
Type	AR208S		AR212S		AR216S		AR220S		AR325S		AR332S		AR440S			
Max. rated current [I _n] (A) *1, *2	IEC, EN, AS		800		1250		1600		2000		2500		3200		4000	
	JIS		800		1250		1600		2000		2500		3200		4000	
	Marine use		800		1250		1600		2000		2500		3200		4000	
N-phase rated current (A)	800		1250		1600		2000		2500		3200		4000			
Number of poles *3, *4	3	4	3	4	3	4	3	4	3	4	3	4	3	4		
Dielectric withstand voltage [U] (50/60Hz) *5	1000		1000		1000		1000		1000		1000		1000			
Operating voltage [U _o] (50/60Hz) *6	690		690		690		690		690		690		690			
Rated breaking/making current [kA sym rms/kA peak]																
IEC, EN, AS [I _{cs} = I _{cu}]	AC 690V *8		50/105		65/143 *10		85/187 *10		65/143		75/165					
	AC 440V		65/143 *10		85/187 *10		65/143		75/165							
	AC 550V		50/105		85/195.5		100/230									
JIS	AC 460V		65/143		85/195.5		100/230									
	AC 220V		50/115		65/153		75/179									
	AC 690V		65/153 *10		85/201 *10		100/245									
For DC	DC 600V *9		40/40		40/40		40/40		40/40		40/40		40/40			
	DC 250V		40/40		40/40		40/40		40/40		40/40		40/40			
Rated short-time current [I _{cs}] [kA ms] (1 sec.)	65		65		85		85		100		100		100			
Rated latching current (kA)	65		65		85		85		100		100		100			
Endurance in number of ON-OFF cycles *11	Mechanical	With maintenance	30000	30000	30000	25000	20000	20000	20000	15000						
		Without maintenance	15000	15000	15000	12000	10000	10000	8000							
	Electrical	AC 460V	12000	12000	12000	10000	7000	7000	3000							
		AC 690V	10000	10000	10000	7000	5000	5000	2500							
Installation	Draw-out or fixed type															
Mass (kg) for draw-out type	73	86	73	86	76	90	79	94	105	125	105	125	139	176		
External dimensions (mm)																
Fixed type *12		a	360	445	360	445	360	445	360	445	466	586	466	586	-	-
		b	460		460		460		460		460		460			
		c	290		290		290		290		290		290			
		d	75		75		75		75		75		75			
Draw-out type *13		a	354	439	354	439	354	439	354	439	460	580	460	580	631	801
		b	460		460		460		460		460		460			
		c	345		345		345		345		345		345			
		d	40		40		40		40		40		40			
Connection method	Line side	Vertical, horizontal or front terminals												Vertical terminals		
	Load side	Vertical, horizontal or front terminals												Vertical terminals		
Control circuit terminal type	screw terminals															
Spring charging method	Manual or motor charging															
Overcurrent release (OCR)	No OCR, L-characteristic for general feeder, R-characteristic for general feeder, or S-characteristic for generator protection															
Operation indication	Individual indication															
Tripping device	Tripping coil (MFI)	Standard equipment for OCR-equipped ACB														
	Shunt trip device (SHI)	Optional														
	undervoltage trip device (UVI)	Optional														
Auxiliary switches	Number of switches	4C (standard), 7C or 10C; available for general feeder or microload														
	Terminal type	screw terminals														
Rated voltage	Control power	AC100 - 120V } shared or		DC100 - 125V } shared or		DC200 - 250V } shared or		DC24V } shared		DC48V } shared						
	Operation power	AC100 - 120V, AC200 - 240V, DC100 - 125V, DC200 - 250V, DC24V or DC48V														
		Power consumption: 5 VA Permissible voltage range: 85 - 110% (AC) or 75 - 110% (DC) of ratings														

*1 Ambient temperature: 40°C (45°C for marine used)

*2 With horizontal terminals for AR208S - 216S and vertical terminals for AR220S - 440S

*3 For 2-pole applications, use two poles at both ends.

*4 4-pole ACBs are not applicable to power distribution IT systems unless N-phase protection is provided.

*5 Varies depending on applicable standards. AC1000V applies to ACBs conforming to IEC60947-2 and JIS C8201-2.

*6 Varies depending on applicable standards. AC690V applies to ACBs conforming to IEC60947-2 and JIS C8201-2.

*7 Applicable to 3-pole ACBs

*8 For applicability to power distribution IT systems, consult us

*9 Applicable under 3-pole serial connection scheme.

*10 For AC500V

*11 Expected service life based on endurance test. The service life of ACB depends on the working and environmental conditions. Refer to chapter 6 "Maintenance, Inspection and Parts Replacement".

*12 For both vertical and horizontal terminals

*13 This manual covers draw-out type ACBs.

Table 4 High-performance types

Frame size (A)			1250	1600	2000	1600	2000	2500	3200							
Type			AR212H	AR216H	AR220H	AR316H	AR320H	AR325H	AR332H							
Max. rated current [I _n] (A) *1, *2	IEC, EN, AS		1250	1600	2000	1600	2000	2500	3200							
	JIS															
		Marine use														
N-phase rated current (A)			1250	1600	2000	1600	2000	2500	3200							
Number of poles *3, *4			3 4	3 4	3 4	3 4	3 4	3 4	3 4							
Dielectric withstand voltage [U _i] (50/60Hz) *5			1000	1000	1000	1000	1000	1000	1000							
Operating voltage [U _o] (50/60Hz) *6			690	690	690	690	690	690	690							
Rated breaking/making current [kA sym rms/kA peak] *7																
IEC, EN, AS [I _{cs} = I _{cu}]	AC 690V *9		55/121				85/187									
	AC 440V		80/176				100/220									
JIS	AC 550V		55/121				85/196									
	AC 460V AC 220V		80/176				100/230									
NK *8	AC 690V		55/128				85/201									
	AC 450V		80/186				100/233									
For DC	DC 600V *10 DC 250V						40/40									
Rated short-time current [I _{tw}] [kA rms] (1 sec.)			80				100									
Rated latching current (kA)			65				85									
Endurance in number of ON-OFF cycles *11	Mechanical	With maintenance	30000	30000	25000	30000	25000	20000	20000							
		Without maintenance	15000	15000	12000	15000	12000	10000	10000							
	Electrical	Without maintenance	AC 460V	12000	12000	10000	12000	10000	7000	7000						
		AC 690V	10000	10000	7000	10000	7000	5000	5000							
Installation			Draw-out or fixed type													
Mass (kg) for draw-out type			79	94	79	94	79	94	105	125	105	125	105	125	105	125
External dimensions (mm)																
Fixed type *12			a	360	445	360	445	360	445	466	586	466	586	466	586	
			b	460												
			c	290												
			d	75												
Draw-out type *13			a	354	439	354	439	354	439	460	580	460	580	460	580	
			b	460												
			c	345												
			d	40												
Connection method		Line side	Vertical terminals (Horizontal terminals can be specified as an option)													
		Load side	Vertical terminals (Horizontal terminals can be specified as an option)													
Control circuit terminal type		screw terminals														
Spring charging method		Manual or motor charging														
Overcurrent release (OCR)		No OCR, L-characteristic for general feeder, R-characteristic for general feeder, or S-characteristic for generator protection														
Operation indication		Individual indication														
Tripping device	Tripping coil (MFI)		Standard equipment for OCR-equipped ACB													
	Shunt trip device (SHI)		Optional													
	undervoltage trip device (UVT)		Optional													
Auxiliary switches		Number of switches	4C (standard), 7C or 10C; available for general feeder or microload													
		Terminal type	screw terminals													
Rated voltage	Control power		AC100 - 120V } shared or AC200 - 240V }				DC100 - 125V } shared or DC200 - 250V }				DC24V } shared or DC48V }					
	Operation power		Power consumption: 5 VA Permissible voltage range: 85 - 110% (AC) or 75 - 110% (DC) of ratings													

- *1 Ambient temperature: 40°C (45°C for marine used)
- *2 For vertical terminals
- *3 For 2-pole applications, use two poles at both ends.
- *4 4-pole ACBs are not applicable to power distribution IT systems unless N-phase protection is provided.
- *5 Varies depending on applicable standards. AC1000V applies to ACBs conforming to IEC60947-2 and JIS C8201-2.
- *6 Varies depending on applicable standards. AC690V applies to ACBs conforming to IEC60947-2 and JIS C8201-2.
- *7 Be sure to enable MCR if instantaneous trip function is not alive. Otherwise, rated breaking current will decrease to rated latching current.
- *8 Applicable to 3-pole ACBs
- *9 For applicability to power distribution IT systems, consult us
- *10 Applicable under 3-pole serial connection scheme.
- *11 Expected service life based on endurance test. The service life of ACB depends on the working and environmental conditions. Refer to chapter 6 "Maintenance, Inspection and Parts Replacement".
- *12 For vertical terminals
- *13 This manual covers draw-out type ACBs.

Use the ACBs in the environmental conditions specified in Table 5.

Table 5 Operating environment

Standard environment (Standard equipped ACBs)	Altitude	2000 m max.
	Ambient temperature	-5°C to +45°C
	Humidity	45 to 85% rel. max.
	Vibration	0.7G max.
	Shock	200 m/s ² (20G) max.
	Atmosphere	No excessive water vapor, oil vapor, dust, or comosive gases. No sudden change in temperature and no condensation. Ammonia (NH ₃): 0.5 ppm max, Hydrogen sulfide (H ₂ S)/sulfur dioxide (SO ₂)/hydrogen chloride (HCl): 0.1 ppm max., Chlorine (Cl ₂): 0.05 ppm max.
Special environment (Optional)	Tropical environment package	Different from standard ACBs in that Ambient temperature: 60°C max. and Humidity: 95% rel. max. (no condensation)
	Cold environment package	Different from standard ACBs in that Ambient temperature: -25°C min. for use and -40°C min. for storage (no condensation)
	Corrosion-resistant package	Different from standard ACBs in that NH ₃ : 50 ppm max, H ₂ S: 10 ppm max., SO ₂ /HCl: 5 ppm max., and Cl ₂ : 1 ppm max.

Table 6 shows the dielectric withstand voltage and the insulation resistance of the ACBs.

⚠ CAUTION	
● Do not perform dielectric withstand/insulation resistance tests under other conditions than specified. Doing so may cause a malfunction.	

Table 6 Dielectric withstand voltage and insulation resistance

Circuit			Dielectric withstand voltage (50/60Hz)			Impulse withstand voltage U_{imp}	Insulation resistance (DC500V Megger used)
Main circuit			Between poles, and terminal group and ground	AC3500V	1 minute	12kV	300M Ω
Control circuit	Auxiliary switches	For general feeder	Between terminal group and ground	AC2500V	1 minute	6kV	100M Ω
		For microload	Between terminal group and ground	AC2000V	1 minute	4kV	100M Ω
	Position switches		Between terminal group and ground	AC2000V	1 minute	4kV	100M Ω
	Overcurrent release		Between terminal group and ground	AC2000V	1 minute	4kV	100M Ω
	Undervoltage trip device, Reverse power trip device		Between terminal group and ground	AC2500V	1 minute	6kV	100M Ω
Other accessories			Between terminal group and ground	AC2000V	1 minute	4kV	100M Ω

The above data applies to new ACBs. Device terminals within ACBs are not covered. Use a DC500V Megger to measure the insulation resistance.

Table 7 shows the internal resistance and power consumption of the ACBs.

Table 7 Internal resistance and power consumption

Type	AR208S	AR212S	AR216S	AR220S	AR325S	AR332S	AR440S
Frame size (A)	800	1250	1600	2000	2500	3200	4000
DC internal resistance (m Ω) (for 1-pole ACB)	0.033	0.033	0.028	0.024	0.014	0.014	0.014
AC power consumption (W) (for 3-pole ACB)	200	350	350	490	600	780	1060

Type	AR212H	AR216H	AR220H	AR316H	AR320H	AR325H	AR332H
Frame size (A)	1250	1600	2000	1600	2000	2500	3200
DC internal resistance (m Ω) (for 1-pole ACB)	0.024	0.024	0.024	0.014	0.014	0.014	0.014
AC power consumption (W) (for 3-pole ACB)	260	350	490	310	430	600	780

Table 8 shows applicable current of the ACBs. The applicable current varies depending on the ambient temperatures.

Table 8 Dependence of applicable current on ambient temperature

Type	Conductor size Ambient temperature (°C)	AR208S	AR212S	AR216S	AR220S	AR325S	AR332S	AR440S
Standard		2 × 50 × 5t	2 × 80 × 5t	2 × 100 × 5t	3 × 100 × 5t	2 × 100 × 10t	3 × 100 × 10t	4 × 150 × 6t
IEC60947-2 EN60947-2 AS3947-2 JIS C8201-2	40 (standard ambient temperature)	800	1250	1600	2000	2500	3200	4000
	45	800	1250	1600	2000	2500	3200	4000
	50	800	1250	1600	2000	2500	3200	4000
	55	800	1200	1540	1820	2500	2990	3940
	60	800	1150	1460	1740	2400	2850	3760
NEMA,SG-3 ANSI C37.13	40 (standard ambient temperature)	800	1250	1540	2000	2500	3200	3700
	45	800	1190	1470	1960	2500	3010	3580
	50	800	1130	1390	1860	2440	2860	3470
	55	790	1070	1310	1750	2300	2690	3350
	60	740	1000	1230	1640	2150	2520	3140
JIS C8372	40 (standard ambient temperature)	800	1250	1600	2000	2500	3200	3700
	45	800	1250	1600	1900	2500	2900	3580
	50	800	1190	1540	1820	2500	2800	3470
	55	800	1130	1460	1740	2400	2710	3350
	60	800	1080	1390	1650	2280	2610	3230
JEC-160	40 (standard ambient temperature)	800	1100	1460	1740	2370	2610	3230
	45	800	1060	1400	1680	2280	2510	3100
	50	800	1010	1340	1600	2180	2400	2970
	55	770	960	1280	1530	2080	2290	2830
	60	730	920	1220	1450	1970	2170	2690

Type	Conductor size Ambient temperature (°C)	AR212H	AR216H	AR220H	AR316H	AR320H	AR325H	AR332H
Standard		2 × 80 × 5t	2 × 100 × 5t	3 × 100 × 5t	2 × 100 × 5t	3 × 100 × 5t	2 × 100 × 10t	3 × 100 × 10t
IEC60947-2 EN60947-2 AS3947-2 JIS C8201-2	40 (standard ambient temperature)	1250	1600	2000	1600	2000	2500	3200
	45	1250	1600	2000	1600	2000	2500	3200
	50	1250	1600	2000	1600	2000	2500	3200
	55	1250	1600	1820	1600	2000	2500	2990
	60	1250	1550	1740	1600	2000	2400	2850
NEMA,SG-3 ANSI C37.13	40 (standard ambient temperature)	1250	1600	2000	1600	2000	2500	3200
	45	1250	1600	1960	1600	2000	2500	3010
	50	1250	1600	1860	1600	2000	2440	2860
	55	1250	1510	1750	1600	1920	2300	2690
	60	1230	1420	1640	1600	1820	2150	2520
JIS C8372	40 (standard ambient temperature)	1250	1600	2000	1600	2000	2500	3200
	45	1250	1600	1900	1600	2000	2500	2900
	50	1250	1600	1820	1600	2000	2500	2800
	55	1250	1550	1740	1600	2000	2400	2710
	60	1250	1480	1650	1600	1900	2280	2610
JEC-160	40 (standard ambient temperature)	1250	1500	1740	1600	2000	2370	2610
	45	1250	1440	1680	1600	2000	2280	2510
	50	1250	1380	1600	1600	2000	2180	2400
	55	1250	1310	1530	1600	1920	2080	2290
	60	1230	1250	1450	1600	1820	1970	2170

Notes: For AR208S, AR212S and AR216S, it is assumed that main circuit terminals are of horizontal type at both the line and load sides. For other types, it is assumed that main circuit terminals are of vertical type at both the line and load sides. The above values may vary depending on the switchboard configuration.

3-2. Parts and Functions

Fig. 12 provides a general views of the ACB.

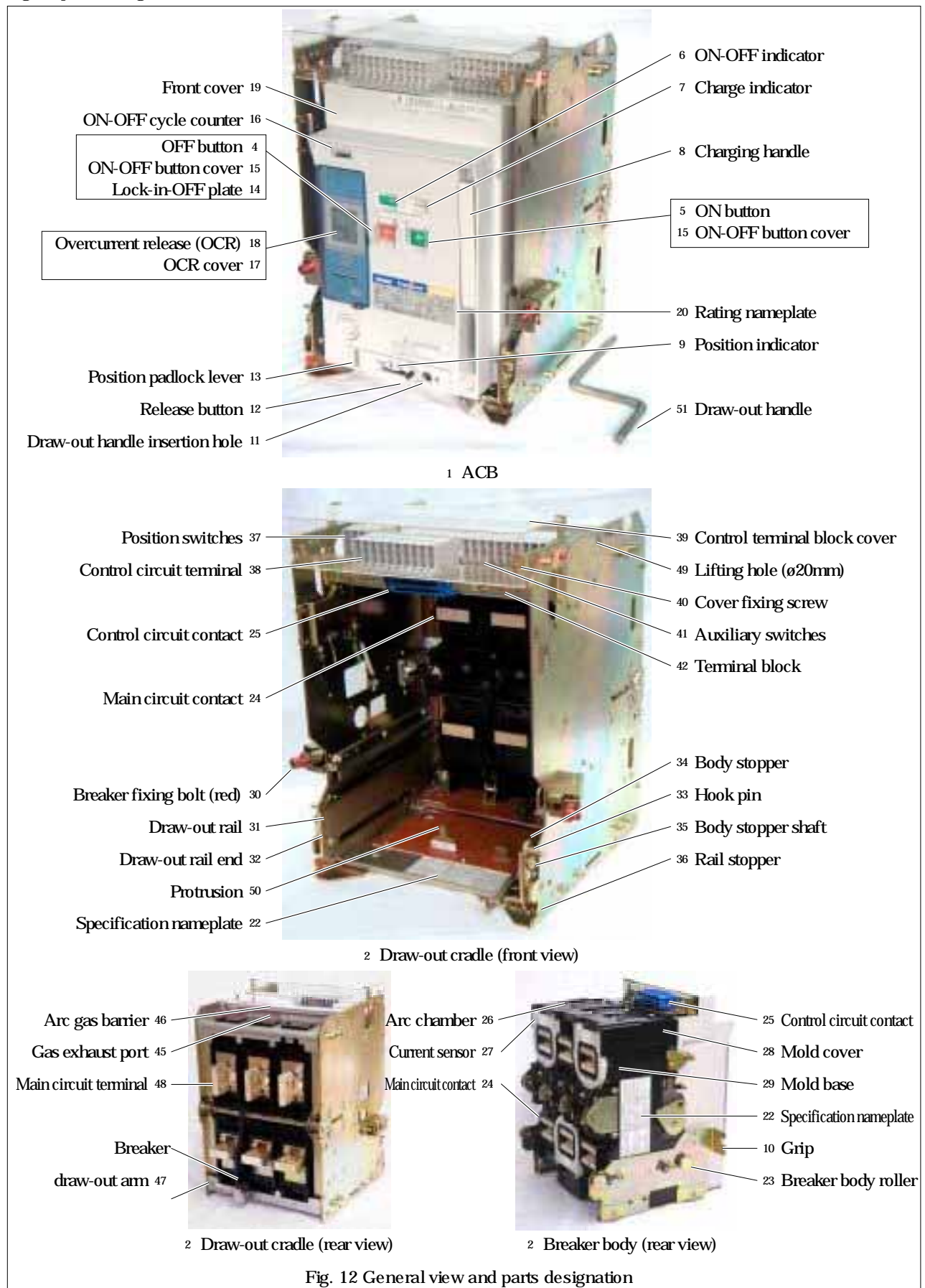
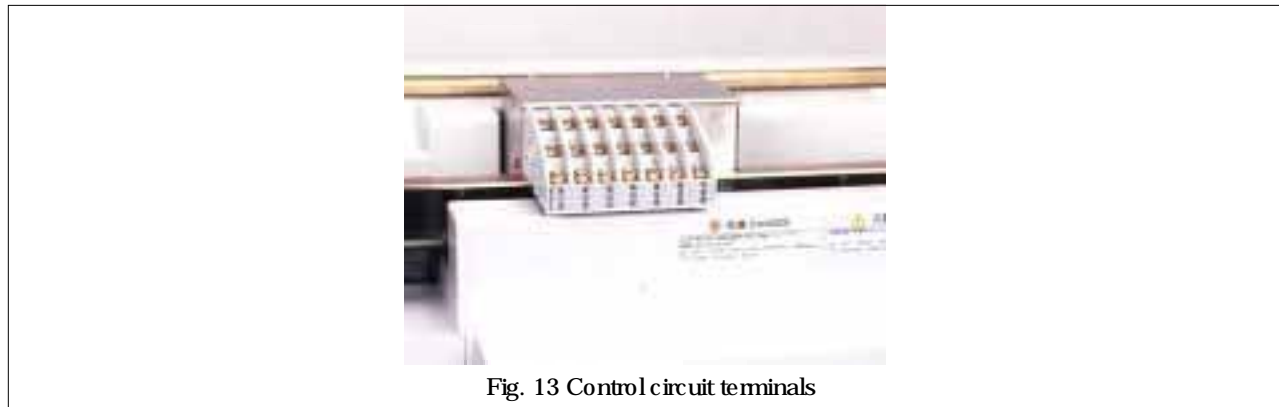

Fig. 12 General view and parts designation

1	ACB	Consists of breaker body ³ and draw-out cradle ² .
2	Draw-out cradle	Comes with main circuit terminals ⁴⁸ , control circuit terminals ³⁸ , auxiliary switches ⁴¹ , and position switches ³⁷ .
3	Breaker body	Contains the ON-OFF mechanism, the closing coil, the tripping device, and overcurrent release ¹⁹ .
4	OFF button	Push to open the ACB.
5	ON button	Push to close the ACB.
6	ON-OFF indicator	Shows "OFF" when the ACB is open and "ON" when it is closed.
7	Charge indicator	Shows "CHARGED" when the closing springs are charged and "DISCHARGED" when it is released.
8	Charging handle	Pump to charge the closing springs.
9	Position indicator	Indicates the present breaker body position: CONN., TEST, or ISOLATED.
10	Grip	Hold to draw out the breaker body.
11	Draw-out handle insertion hole	Insert the draw-out handle into this hole to move the breaker body.
12	Release button	Push to move the breaker body from the TEST position.
13	Position padlock lever (optional)	Accommodates up to three padlocks to lock the breaker body in the CONN., TEST or ISOLATED position. (Padlocks are not supplied. Use padlocks with a 6 mm-diameter shackle.)
14	Lock-in-OFF plate (optional)	Padlocking this plate allows the ACB to be locked in the open (OFF) state. (Padlocks are not supplied. Use padlocks with a 6 mm-diameter shackle.)
15	ON-OFF button cover	Provides protection against inadvertent button operation and can be padlocked. (Padlocks are not supplied. Use padlocks with a 6 mm-diameter shackle.) Up to three padlocks can be installed.
16	ON-OFF cycle counter (optional)	Reads the number of ON-OFF cycles. It counts a series of operations from close to open as one cycle.
17	OCR cover	Padlocking this plate prevents settings of overcurrent release ¹⁸ to be inadvertently changed. (Padlocks are not supplied. Use padlocks with a 6 mm-diameter shackle.)
18	Overcurrent release (OCR)	This protective device is supplied power via the power CT installed in the ACB main circuit. When the current sensor detects an overcurrent in the main circuit, the OCR instructs the magnet hold trigger (MHT) to trip open the ACB.
19	Front cover	A plastic cover of the breaker body front panel.
20	Rating nameplate	Indicates the type, applicable standards and rated breaking capacity of the ACB.
22	Specification nameplate	Indicates the number of poles, operation method, accessories, and serial number of the ACB.
23	Breaker body roller	Allows breaker body ³ to be moved on draw-out rail ³¹ .
24	Main circuit contact	Closes when the breaker body is in the CONN. position.
25	Control circuit contact	Closes when the breaker body is in the CONN. or TEST position.
26	Arc chamber	Extinguishes the arc that occurs in the breaking operation. Two arc chambers are fitted per pole. See 6-2-2. "Arc chambers".
27	Current sensor	Converts the current in the main circuit into a voltage signal in proportion to the magnitude of the current and sends the signal to overcurrent release ¹⁸ .
28	Mold cover	A plastic cover of the breaker body side face.
29	Mold base	A plastic cover of the breaker body rear face.
30	Breaker fixing bolt (red) (optional)	Allows the breaker body to be locked in the CONN. position even if the ACB is subject to strong vibrations. Standard equipped on ACBs that conform to ship classification society rules.
31	Draw-out rail	Use to draw out the breaker body from the draw-out cradle.
32	Draw-out rail end	Refer to chapter 1 "Operation Precautions".
33	Hook pin	Refer to chapter 1 "Operation Precautions".
34	Body stopper	Prevents the breaker body from falling when the body is drawn out from the draw-out cradle.
35	Body stopper shaft	Refer to chapter 1 "Operation Precautions".
36	Rail stopper (red)	Allows the draw-out rail to be locked in the drawn-out or retracted state.
37	Position switches (optional)	Indicate the present breaker body position: CONN., TEST, ISOLATED or INSERTED. The position switches are available in 2C or 4C configuration. Connections to the position switches are made through M4 screws.

38	Control circuit terminals	Allow connections of external control wire to the control circuits. Wire connections are made through M4 screw terminals. Fig. 13 shows the control circuit terminals.
----	---------------------------	------------------------------------------------------------------------------------------------------------------------------------------------------------------------



39	Control terminal block cover (optional)	Protects the position switches, the control circuit terminals and the auxiliary switches from damage.
40	Cover fixing screw	Secures the control terminal block cover.
41	Auxiliary switches (optional)	Indicate the state of the ACB (ON or OFF). The auxiliary switches are available in 4C configuration (standard), or 7C or 10C configuration (optional). Connections to the switches are made through M4 screw terminals.
42	Terminal block	Contains position switches 36, control circuit terminals 37, and auxiliary switches 38.
44	Ground terminal M8 tapped hole	Allows connection of a ground terminal.
45	Gas exhaust port	Allows the arc gas to be discharged from arc chamber 25 in a horizontal direction when the ACB trips open.
46	Arc gas barrier	Prevents the arc gas from being discharged upwards from arc chamber 25 when the ACB trips open.
47	Breaker draw-out arm	Is retracted in the draw-out cradle when the breaker body is in the CONN. position.
48	Main circuit terminals	Allow connections of external conductors. These terminals are available in three configurations as shown in Fig. 14.



49	Lifting hole (ø20mm)	Allows lifting attachments or wire ropes to be used for lifting the ACB.
50	Protusion	Refer to section 2-3. "Installation Precautions".
51	Draw-out handle (removable)	Use to draw out /insert the breaker body from/into the draw-out cradle.

3-3. Circuits and Ratings

Fig. 15 shows an ACB circuit diagram and Table 9 and Fig. 16 show the function of each terminal and the meaning of each sign in the diagram.

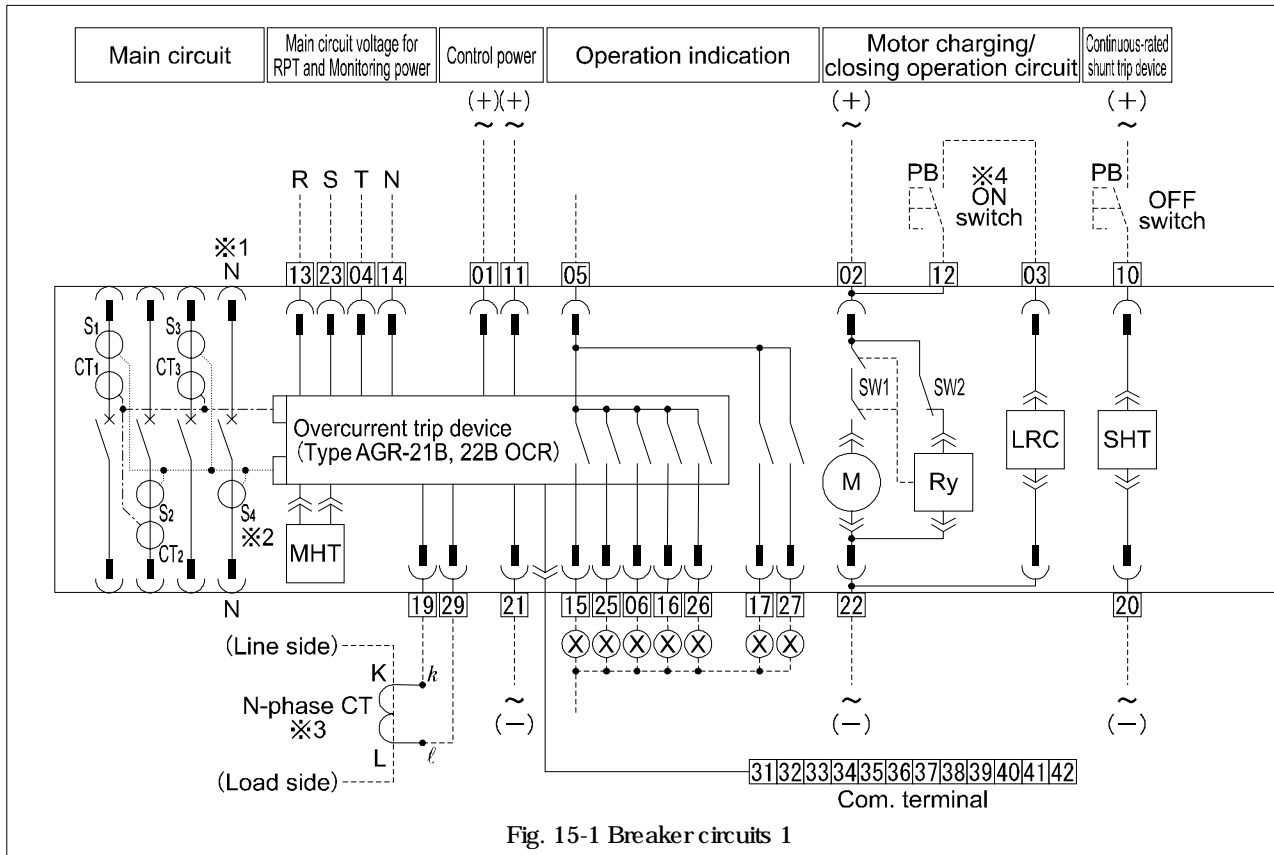

Fig. 15-1 Breaker circuits 1

Table 9-1 Terminal functions and circuit symbols 1 (Applicable to both 50 and 60Hz for AC. ⊕ and ⊖ mean the polarity for DC)

Function	Terminal No.	Remarks				
Control power supply	01, 11, 21	Connect the unit to the applicable terminal Nos.	Terminal No.	Circuit voltage		
				When compatible with both AC100 - 120V and AC200 - 240V power *5	When compatible with both DC100 - 125V and DC200 - 250V power *5	When compatible with both DC24V and DC48V power *5
			01 - 11	AC100 - 120V	NA	NA
			11 ⊕ - 21 ⊖	NA	DC100 - 125V	DC24V
Operation power	02 ⊕ - 22 ⊖	AC100 - 120V, AC200 - 240V, DC100 - 125V, DC200 - 250V, DC24V or DC48V *5				
ON switch	03 - 12					
Undervoltage trip device power	08, 09, 18, 28	Connect the unit to the applicable terminal Nos.	Terminal No.	Circuit voltage		
				AC100V compatible *5	AC200V compatible *5	AC400V compatible *5
			08 - 09	AC100V	AC200V	AC380V
			09 - 18	AC110V	AC220V	AC415V
OFF switch	24 - 30	Available for ACBs equipped with undervoltage trip device				
Continuous-rated shunt trip device power and OFF switch	10 - 20	AC100V, AC110V, AC120V, AC200V, AC220V, AC240V, DC24V, DC48V, DC100V, DC110V, DC125V, DC200V or DC220V *5				
Operation indication	05 - 15	Long time delay trip (LT)				
	05 - 25	Short time delay (ST) and instantaneous trip (INST/MCR)				
	05 - 06	Pretrip alarm (PTA)				
	05 - 16	Ground fault trip (GF) or reverse power trip (RPT) *5				
	05 - 26	System alarm				
	05 - 17	Line side ground fault (REF), negative-phase sequence protection (NS), contact overheat monitoring (OH) or tripping operation *5				
	05 - 27	Pretrip alarm 2 (PTA2), undervoltage alarm (UV) or spring charge operation *5				
Main circuit input voltage	13, 23, 04, 14	R-phase - 13, S-phase - 23, T-phase - 04, N-phase - 14				
Separate N-phase CT	19 - 29 (31 - 32)	When the ACB is equipped with the undervoltage trip device, connect the CT between 31 and 32. Polarity: 19 (31) - k, 29 (32) - l *3				
Line side ground fault protection (REF) CT	35 - 36	Polarity: 35 - k, 36 - l				
Zone interlock control power	33 ⊕ - 34 ⊖	DC24V				
Zone interlock signal I/O	37, 38, 39, 40	See Fig. 19.				
Communication signal I/O	41, 42					
(Reserved)	07					

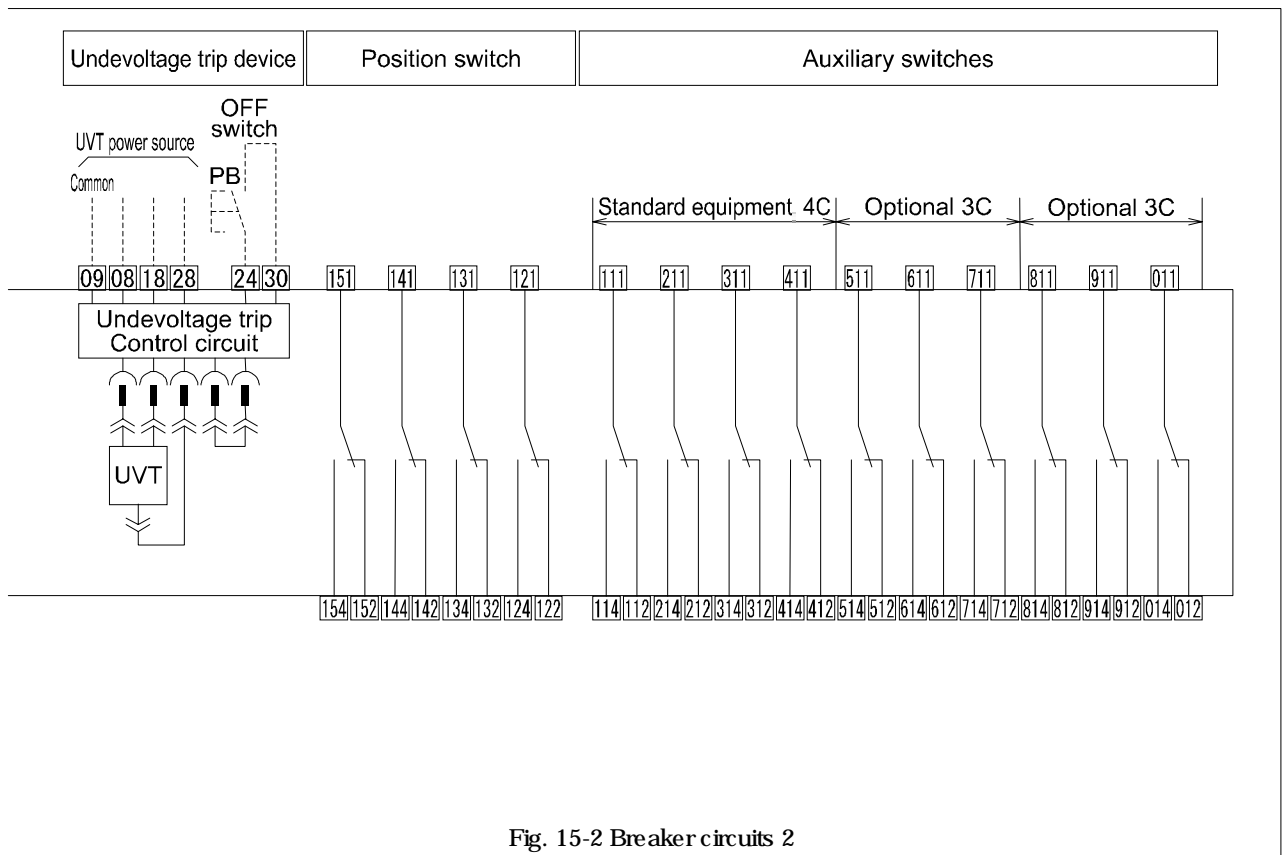

Fig. 15-2 Breaker circuits 2

Table 9-2 Terminal functions and circuit symbols 2

Symbol	Meaning	Symbol	Meaning
$S_1 - S_4$	Current sensors *6	LRC	Latch release coil
$CT_1 - CT_3$	Power supply CT *7	SHI	Shunt trip device
MHT	Magnet hold trigger	UVT	Undervoltage trip device
M	Spring charging motor		Main/control circuit contact
Ry	Control relay		Hand connector
SW1	Spring charged "OFF" switch	----	User wiring
SW2	Control relay a contact		Relay or LED

*1 For 4-pole ACBs.

*2 For 4-pole ACBs equipped with N-phase protection and/or ground fault trip functions.

*3 Used for 3-pole ACBs with ground fault trip functions to be installed in a 3-phase, 4-wire circuit.

*4 Do not connect the ON switch with auxiliary switch b-contact in series. Doing so may cause pumping.

*5 To be stated when ordering

*6 Conversion ratio: CT rated primary current I_{CT} (A)/150 mV

*7 Provide power to the overcurrent trip device when control power is lost.

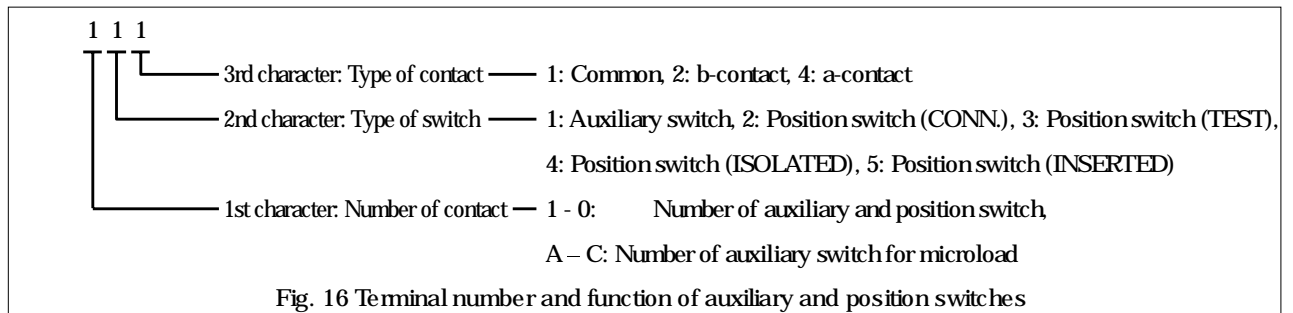

Fig. 16 Terminal number and function of auxiliary and position switches

Fig. 17 provides the terminal arrangement of the ACB.

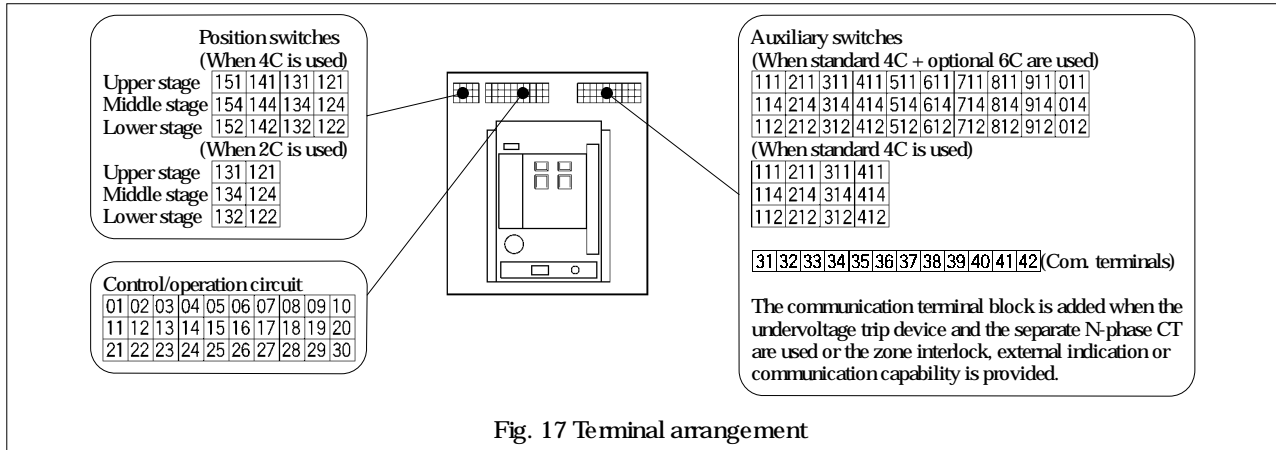

Fig. 17 Terminal arrangement

Fig. 18 shows how to connect the line side ground fault protection (REF) CT when the overcurrent release (OCR) is provided with the REF capability. See Fig. 15 for other circuits than that of the line side ground fault protection CT.

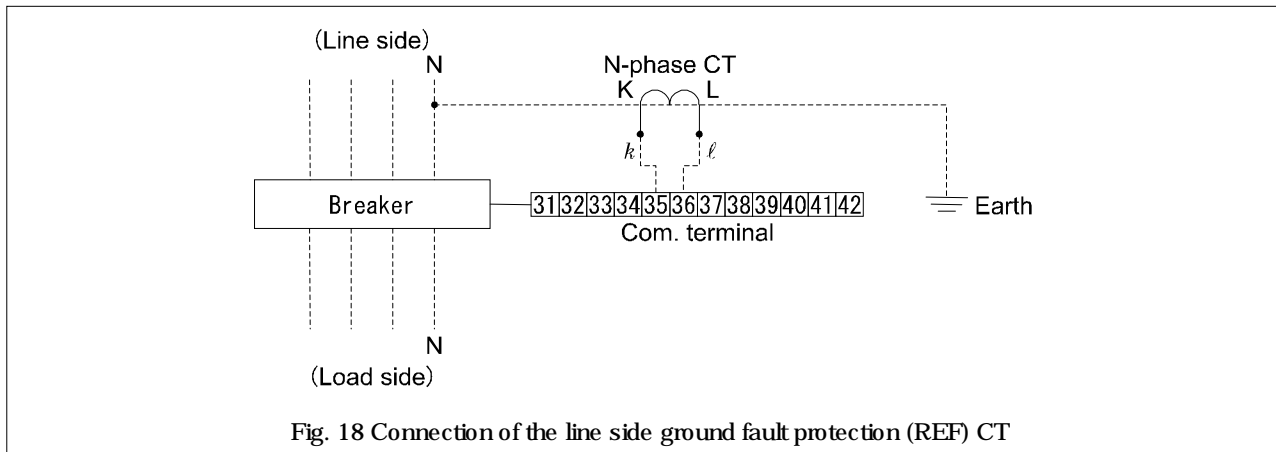

Fig. 18 Connection of the line side ground fault protection (REF) CT

Fig. 19 shows how to connect ACBs when the overcurrent release (OCR) is provided with the zone interlock (Z) capability. See Fig. 15 for other circuits than that of the zone interlock.

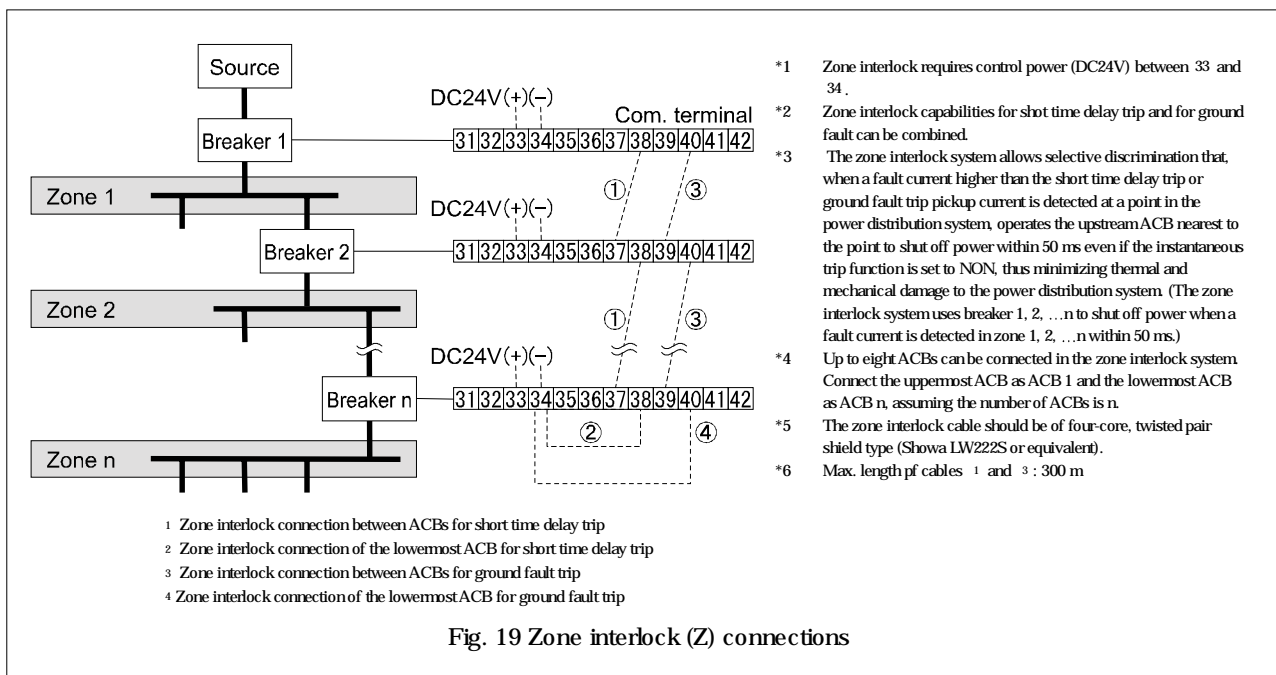

Fig. 19 Zone interlock (Z) connections

Tables 10 - 15 show the ratings of the operation power supply, the shunt trip device (SHI), the undervoltage trip device (UVT), auxiliary switches, position switches, operation indication contacts, and the N-phase CT.

Table 10 Ratings of operation power supply

Rated voltage (V)	Permissible charging/closing voltage range	Ratings of operation power supply			
		Peak motor starting current (A)	Steady-state motor current (A)	Peak making current (A)	Latch release coil (LRC) resistance (ohm) *
AC100	85 - 110	7	1.1	0.48	180-230
AC110	94 - 121	7	1.1	0.39	220-280
AC120	102 - 132	7	1.1	0.37	260-330
AC200	170 - 220	4	0.7	0.24	750-920
AC220	187 - 242	4	0.7	0.19	910-1120
AC240	204 - 264	4	0.7	0.18	1060-1300
DC24	20 - 26	14	4	1.65	13-16
DC48	41 - 53	10	1.6	0.86	49-61
DC100	85 - 110	6	0.8	0.39	220-280
DC110	94 - 121	6	0.8	0.37	260-330
DC125	106 - 138	6	0.8	0.31	350-440
DC200	170 - 220	4	0.5	0.19	910-1120
DC220	187 - 242	4	0.5	0.18	1060-1300

* Ambient temperature: 20°C

Table 11 Ratings of shunt trip device (SHI)

Rated voltage (V)	Permissible voltage range (V)	Peak exciting current (A)	Steady-state current (A)	Coil resistance (ohm) *	Max. contact parting time (ms)
AC100	70 - 110	0.48	0.32	180-230	40
AC110	77 - 121	0.39	0.26	220-280	
AC120	84 - 132	0.37	0.24	260-330	
AC200	140 - 220	0.24	0.16	750-920	
AC220	154 - 242	0.19	0.13	910-1120	
AC240	168 - 264	0.18	0.12	1060-1300	
DC24	16.8 - 26.4	1.65	1.1	13-16	
DC48	33.6 - 52.8	0.86	0.57	49-61	
DC100	70 - 110	0.39	0.26	220-280	
DC110	77 - 121	0.37	0.25	260-330	
DC125	87.5 - 137.5	0.31	0.21	350-440	
DC200	140 - 220	0.19	0.13	910-1120	
DC220	154 - 242	0.18	0.12	1060-1300	

* Ambient temperature: 20°C

Table 12 Ratings of undervoltage trip device (UVT)

Rated voltage (V)	Opening voltage range (V)	Attraction voltage (V)	Coil exciting current (A)	Power consumption (VA)		Coil resistance (ohm) *
				Normal	Attraction	
AC100	35 - 70	85	0.1	8	10	Holding coil: 410 - 510 Attraction coil: 5.6-6.8
AC110	38.5 - 77	93.5				
AC120	42 - 84	102				
AC200	70 - 140	170				
AC220	77 - 154	187				
AC240	84 - 168	204				
AC380	133 - 266	323				
AC415	145 - 290	352				
AC440	154 - 308	374				
DC24	8.4-16.8	20.4				
DC48	16.8-33.6	40.8				
DC100	35-70	85				

* Ambient temperature: 20°C

Table 13 Ratings of auxiliary and position switches

Voltage (V)	Auxiliary switches *1 *2				Position switches	
	For general feeder		For microload *3		Resistive load (A)	Inductive load (A) *5
	Resistive load (A)	Inductive load (A) *4	Resistive load (A)	Inductive load (A) *5		
AC100 - 250	5	5	0.1	0.1	11	6
AC251 - 500	5	5	-	-	-	-
DC8	-	-	-	-	10	6
DC30	1	1	0.1	0.1	6	5
DC125	-	-	-	-	0.6	0.6
DC250	-	-	-	-	0.3	0.3
DC125 - 250	1	1	-	-	-	-

*1 Using b-contact results in contact chatter of 20 ms or less when the ACB opens or closes.

*2 Do not apply different voltages to contacts of a switch.

*3 Min. applicable load: DC5V/1 mA

*4 AC $\cos\phi \geq 0.3$, DC L/R ≤ 0.01

*5 AC $\cos\phi \geq 0.6$, DC L/R ≤ 0.007

Table 14 Ratings of operation indication contacts

Voltage (V)	Rated contact current (A)			
	Individual indication Long-time delay trip, short-time delay trip, instantaneous trip, pretrip alarm, ground fault trip, system alarm		Spring charging/tripping operation	
	Resistive load (A)	Inductive load (A) *1	Resistive load (A)	Inductive load (A) *1
AC250	0.5	0.2	3	3
DC30	2	0.7	3	2
DC125	0.5	0.2	0.5	0.5
DC250	0.27	0.04	0.1	0.1

*1 AC $\cos\phi \geq 0.6$, DC L/R ≤ 0.007

Table 15 Ratings of N-phase CT

Type of ACB	Type of N-phase CT	Ratings (A)		
AR208S, AR212S, AR216S	CW80-40LS	200/5A	400/5A	800/5A
AR212H, AR216H, AR316H		1250/5A	1600/5A	
AR220S, AR325S, AR332S, AR440S	EC160-40LS	1600/5A	2000/5A	2500/5A
AR220H, AR320H, AR325H, AR332H		3200/5A	4000/5A	

4. OPERATION

4-1. Charging and Opening operation

⚠ DANGER

- Never touch live terminal parts. Otherwise, electric shock may result.

⚠ CAUTION

- Do not force down the charging handle after completion of manual charging operation. Doing so may cause a malfunction.
- The permissible operating voltage of the spring charging motor is 85 to 110% of the rated ac voltage or 75 to 110% of the rated dc voltage. Be sure to supply a voltage within the above ranges to the motor. Otherwise, burnout may result.
- Repeated open/close operation by the motor charging mechanism without pause should not exceed 15 times. If repeated continuous open/close operation is inevitable, a pause of at least 20 minutes should be provided after the repetitions of 15 times. Otherwise, a spring charging motor may be burnt out.
- Do not bring your hand or face close to arc gas vent of the arc chamber while the ACB is energized. Otherwise, a burn may result from high-temperature arc gas blowing out of the arc gas vent when the ACB trips open.
- If the ACB trips open automatically, remove the cause of tripping operation before re-closing the ACB. Otherwise, a fire could result.
- If the ACB has the breaker fixing bolts, make sure the bolts on both sides are securely tightened before using the ACB. Loosened fixing bolts may cause a malfunction of the ACB, in particular when it is installed in such an area that is subject to strong vibrations.

The ACBs are available in two types in terms of the closing spring charging method and the remote operation capability: a manual charging type and a motor charging type. The manual charging type requires the charging and ON-OFF (close/open) operation to be done manually while the motor charging type allows the operation to be done either manually or by using a motor.

4-1-1. Charging operation

The ACB can be closed only when the closing springs have been charged. Be sure to charge the closing springs before closing the ACB. The charging operation is permitted, regardless of whether the ACB is ON (closed) or OFF (open). The procedure for charging the closing springs is as follows:

- Manual charging

Pump the charging handle (Fig. 20 2) until the charge indicator (Fig. 20 1) shows “CHARGED” Pumping the handle with the full stroke 10 - 13 times will fully charge the closing springs.

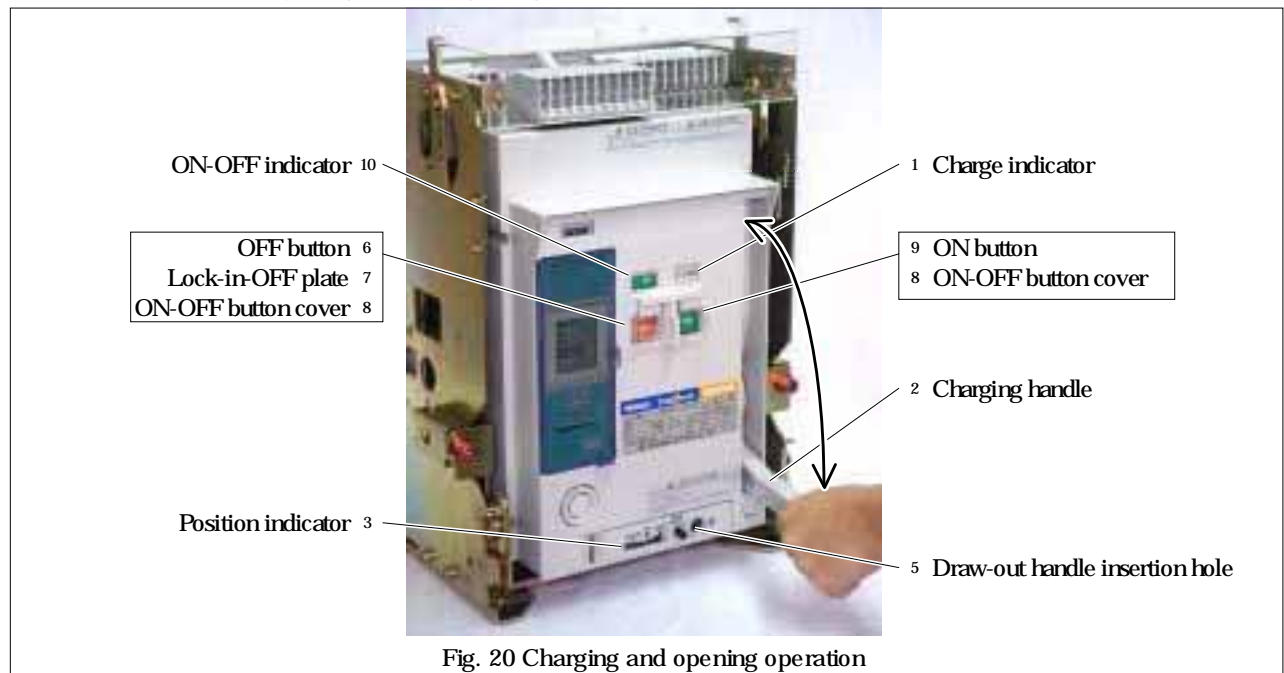

● **Motor charging**

When the charge indicator (Fig. 20 1) changes to “DISCHARGED” while the specified operation voltage is applied to the control circuit terminals 02 and 22 , the charging motor is activated to start charging the closing springs. Upon completion of the charging operation, the charge indicator shows “CHARGED” and the charging motor is automatically deactivated. The time required for the motor charging operation depends on the operation voltage or the ACB types, but does not exceed 10 seconds.

4-1-2. Closing operation

The ACB closing operation is not permitted unless all of the following conditions are met

- 1) The charge indicator (Fig. 20 1) shows "CHARGED".
- 2) The position indicator (Fig. 20 3) shows "CONN.", "TEST" or "ISOLATED" (a halfway position not permitted).
- 3) The draw-out handle is not inserted in the draw-out handle insertion hole(Fig. 20 5) .
- 4) The OFF button (Fig. 20 6) is not locked with the lock-in-OFF plate (Fig. 20 7).
- 5) The specified voltage is supplied to the undervoltage trip device .

The control power of the overcurrent release (OCR) must be supplied before closing operation in order that the internal program can be started. If the OCR trips open directly after the control power is supplied to the OCR, operation indication may be incorrect.

● **Manual closing**

Open the ON-OFF button cover (Fig. 20 8) and press the ON button (Fig. 20 9). The ACB will be closed with a sound. The ON-OFF indicator (Fig. 20 10) shows "ON" and the charge indicator (Fig. 20 1) shows "DISCHARGED".

● **Electrical closing**

Press the ON switch shown in Fig. 15. The latch release coil (LRC) (Fig. 15) will be excited and the ACB is closed with a sound. The ON-OFF indicator (Fig. 20 10) shows "ON", the charge indicator (Fig. 20 1) shows "DISCHARGED", and the charging motor starts charging the closing springs.

4-1-3. Opening operation

● **Manual opening**

Open the ON-OFF button cover (Fig. 20 8) and press the OFF button (Fig. 20 16). The ACB will trip open with a sound. The ON-OFF indicator (Fig. 20 10) shows "OFF".

● **Electrical opening**

Press the OFF switch shown in Fig. 15. The shunt trip device (SHT) or the fixed type undervoltage trip device (Fig. 15) will be excited so that the ACB trips open with a sound. The ON-OFF indicator (Fig. 20 10) shows "OFF".

4-1-4. Motion of trip indication and spring charge indication switches

The trip indication and spring charge indication switches provide the breaker status as shown in Table 16.

Table 16 Motion of trip indication and spring charge indication switches

Type of OCR	Operation	Terminal No. See Fig. 15	Contact output				
			State				
			Closing spring		ACB closed	ACB open	
Charged	Discharged	Not ready to close *	Ready to close *				
All	Trip	05 , 17	No change	No change	OFF	ON	OFF
	Spring charge	05 , 27	ON	OFF	No change	No change	No change

* "Ready to close" means that all of the following conditions are met:
 1. The closing springs are charged.
 2. Opening operation is complete (At least 40 ms has elapsed after trip signal was produced).
 3. The OFF button is released.
 4. The specified voltage is applied to the undervoltage trip device (if equipped).

4-1-5. Motion of operation mechanisms

Figs. 21 - 24 illustrate the motion of the charging and ON-OFF mechanisms.

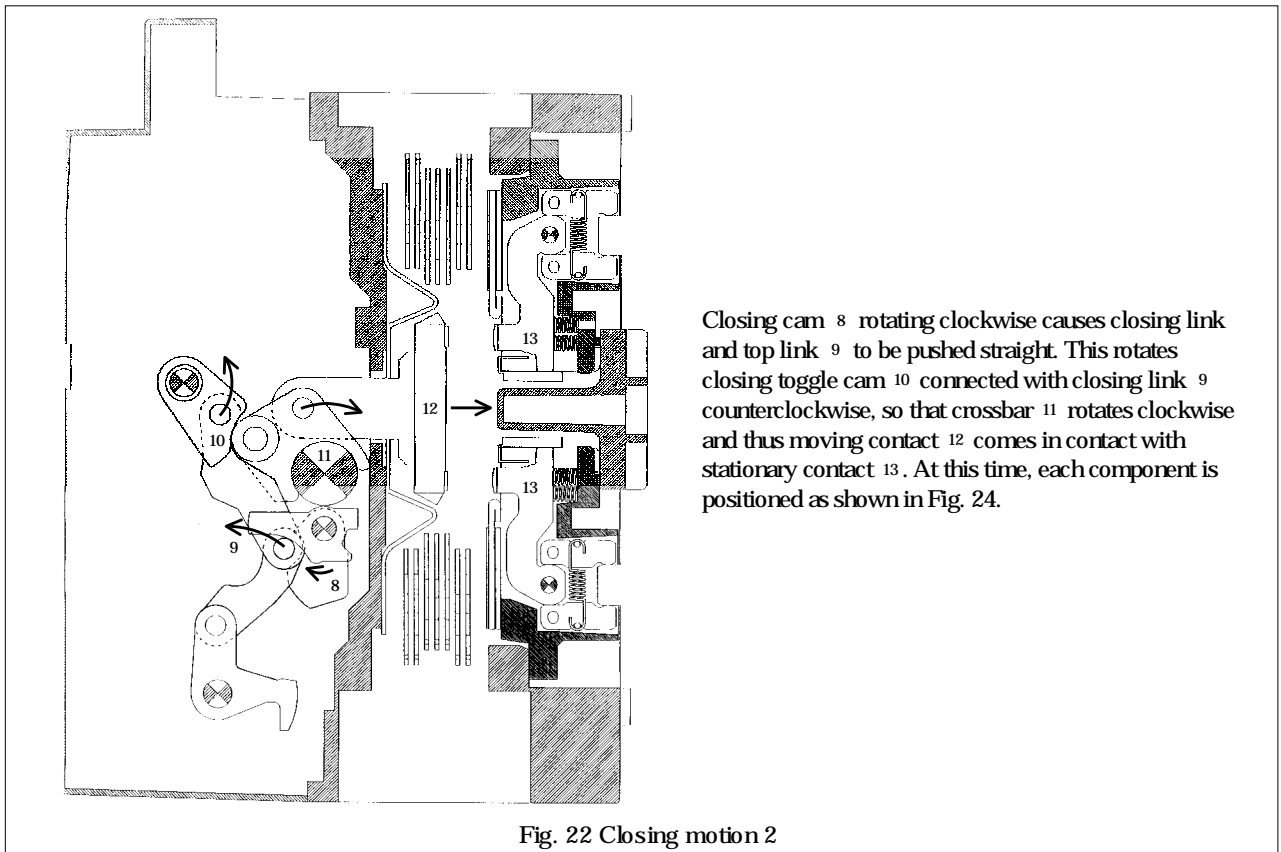
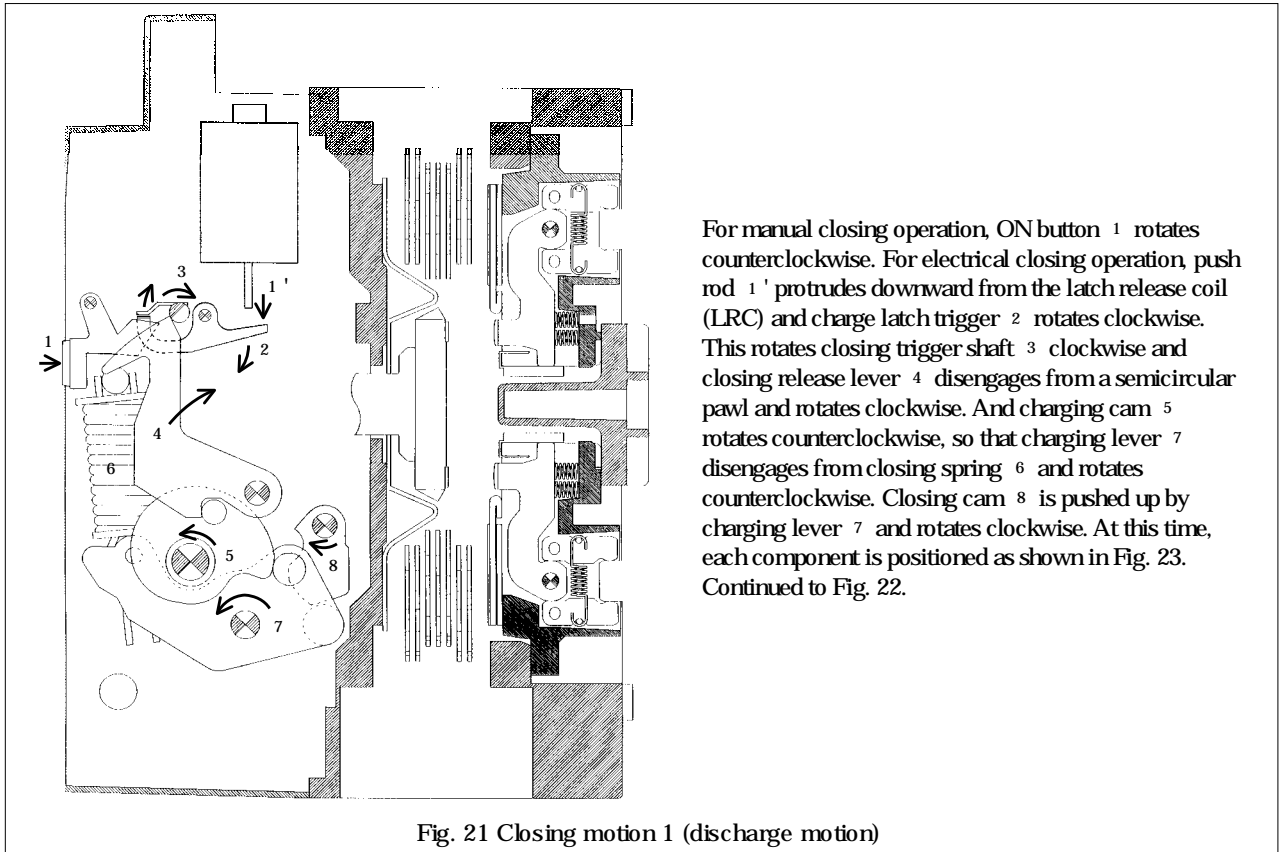

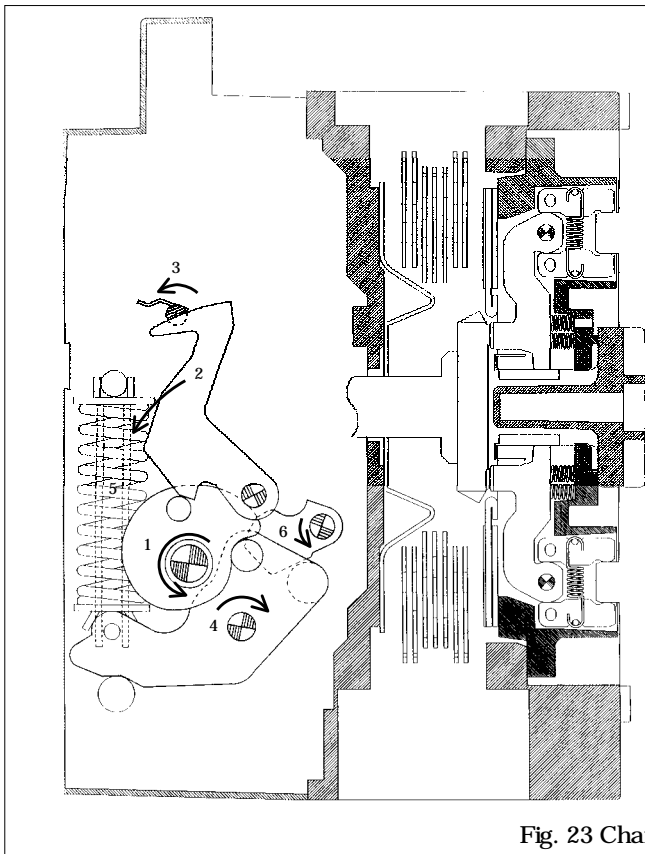

Fig. 23 Charging motion

The charging handle or the charging motor provides a counterclockwise rotation to charging cam 1 . This rotates closing release lever 2 and closing tripper lever 3 counterclockwise and a semicircular pawl engages with closing release lever 2 . And charging lever 4 rotates clockwise so that closing spring 5 is compressed and closing cam 5 rotates counterclockwise. At this time, each component is positioned as shown in Fig. 21.

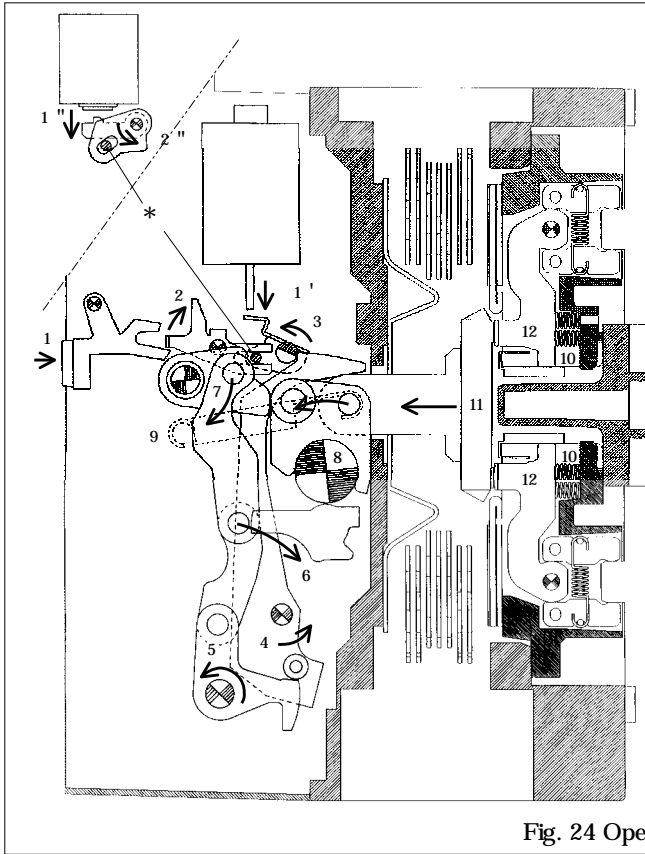

Fig. 24 Opening motion

For manual opening operation, OFF button 1 rotates counterclockwise and trip linkage 2 rotates clockwise. For electrical opening operation, push rod 1 protrudes downward from the shunt trip device (SHT) or the undervoltage trip device (UVT). For tripping operation by the overcurrent release (OCR), moving core 1 protrudes downward from the magnet hold trigger (MHT) and trip linkage 2 rotates counterclockwise. (Parts marked with an asterisk (*) are trip pins. To avoid superposition in the figure, magnet hold trigger related parts are drawn in positions that are different from actual positions. This rotates trip trigger shaft 3 counterclockwise and trip lever B 4 disengages from a semicircular pawl and rotates counterclockwise. And trip lever A 5 rotates counterclockwise, trip link 6 moves to a lower right direction and closing toggle cam 7 rotates clockwise. The force of closing spring 9 and contact spring 10 rotates crossbar 8 counterclockwise, so that moving contact 10 is parted from stationary contact 12 . At this time, each component is positioned as shown in Fig. 22.

4-2. Draw-out and Insertion Operation

4-2-1. General

The draw-out type ACB consists of the breaker body and the draw-out cradle. The main and control circuit terminals are installed on the draw-out cradle, which permits you to draw out and inspect or service the breaker body without the need for removing wiring from the terminals.

The draw-out mechanism allows you to move the breaker body to any of the four positions as shown in Fig. 25. The switchboard panel door can be shut with the breaker body drawn out to the CONN., TEST or ISOLATED position.

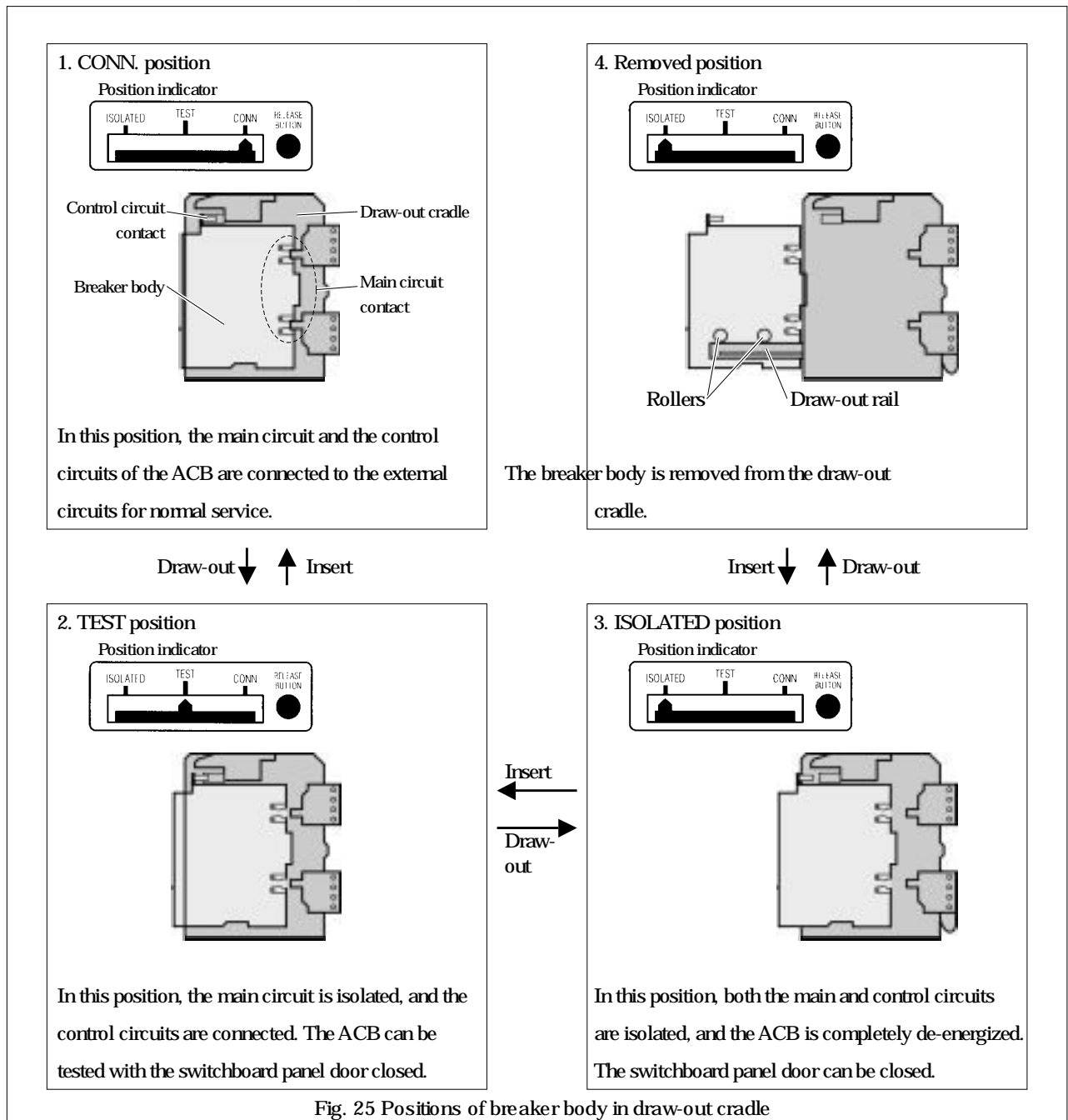

Fig. 25 Positions of breaker body in draw-out cradle

● Operation Durability

The AR series ACBs are designed to ensure the operation durability of 100 draw-out and insertion cycles in conformance to IEC 60947-1 and JIS C8201-2 (one cycle means that the breaker body is drawn out from the CONN. position to the Removed position and inserted back to the CONN. position). Draw-out and insertion operation of more than 100 cycles could abrade the main circuit contacts, resulting in an overheat of the contacts during energization.

4-2-2. Draw-out operation

⚠ DANGER

- Never touch live terminal parts. Otherwise, electric shock may result.
- Do not leave the ACB body in the removed position. The weight of the ACB may cause serious injury.

⚠ CAUTION

- If the ACB has the breaker fixing bolts, be sure to loosen the bolts on both sides before draw-out operation. Otherwise, damage to the ACB may result.
- Make sure the draw-out cradle is secured with mounting screws before drawing out the breaker body. Otherwise, the draw-out operation may cause the breaker body or the draw-out cradle to fall, resulting in damage to the ACB or personal injury.
- When retracting the draw-out rail into the draw-out cradle, be sure to push the rail end. Do not hold the hook pin, body stopper, or body stopper shaft. Doing so may cause your fingers to be pinched, resulting in injury.

Use the separate draw-out handle to draw-out the breaker body.

4-2-2-1. Moving the breaker body from the CONN. position to the TEST position

- 1) Open the ACB. (If the ACB remains closed, the draw-out handle (Fig. 26 1) cannot be inserted).
 - 2) Loosen the breaker fixing bolts (Fig. 26 2), if used, to unlock the breaker body (Fig. 26 3).
 - 3) Unlock the position lock lever (Fig. 26 14) if locked. See section 4-5.
 - 4) Insert the draw-out handle into the draw-out handle insertion hole (Fig. 26 4) and slowly turn counterclockwise until the position indicator (Fig. 26 5) shows "TEST".
- When the main circuit is disconnected at the disconnect contacts, the breaker body will be slightly pushed forward by the spring action of the main circuit disconnect contacts. At this moment, a bang sound will be heard. This sound does not mean a malfunction.
 - The ACB cannot be closed as long as the draw-out handle is in the draw-out handle insertion hole. To close the ACB e.g., for ON-OFF testing, remove the draw-out handle.

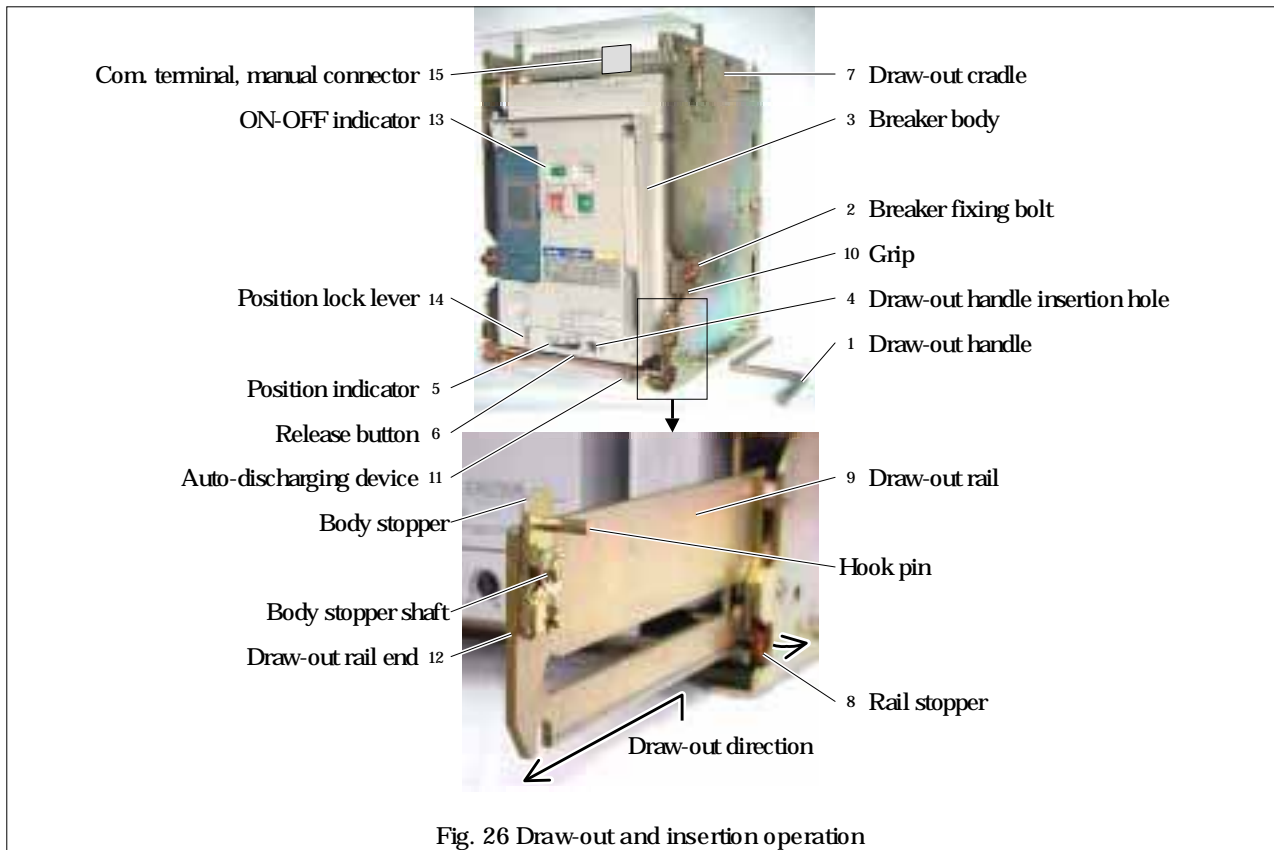

4-2-2-2. Moving the breaker body from the TEST position to the ISOLATED position

- 1) Open the ACB. (If the ACB remains closed, the draw-out handle (Fig. 26 1) cannot be inserted).
- 2) Press the release button (Fig. 26 6). The release button will be locked depressed.
- 3) Unlock the position lock lever (Fig. 26 14) if locked. See section 4-5.
- 4) Insert the draw-out handle into the draw-out handle insertion hole (Fig. 26 4) and slowly turn counterclockwise until the position indicator (Fig. 26 5) shows “ISOLATED” and a freewheeling sound is heard. Turning the draw-out handle will unlock the release button.
- 5) Remove the draw-out handle.

4-2-2-3. Moving the breaker body from the ISOLATED position to the removed position

- 1) Make sure the draw-out cradle (Fig. 26 7) is secured with mounting screws.
- 2) Unlock the position lock lever (Fig. 26 14) if locked. See section 4-5.
- 3) Push the rail stoppers (Fig. 26 8) outward on both sides of the draw-out cradle to unlock the draw-out rail (Fig. 26 9), and then uphold and pull out the rail until it stops. The draw-out rail will be locked again by the stoppers. (The breaker body cannot be drawn out unless the rail is locked).
- 4) Holding both the grips (Fig. 26 10), draw out the breaker body until it stops.
 - If the ACB is equipped with the communication terminal block, pull out the hand connector (Fig. 26 15) from the communication terminal block while drawing out the breaker body. Make sure the hand connector and control wire of the ACB are not snagged when drawing out the breaker body again.
 - If the ACB is equipped with an optional auto-discharging device (Fig. 26 11), the closing springs of the ACB will be automatically discharged with a mechanical sound. This sound does not mean a malfunction.
 - Do not leave the ACB body on the draw-out rail pulled out.
- 5) Use an optional lifter or lifting plate to transfer the breaker body (Fig. 26 3) to a safe place. Refer to section 2-1-2.

4-2-3. Putting the breaker body back into the draw-out cradle

 DANGER
<ul style="list-style-type: none">● Never touch live terminal parts. Otherwise, electric shock may result.● Do not leave the ACB body in the removed position. The weight of the ACB may cause serious injury.

 CAUTION
<ul style="list-style-type: none">● Make sure the draw-out cradle is secured with mounting screws before inserting the breaker body into the draw-out cradle. Otherwise, the insertion operation may cause the breaker body or the draw-out cradle to fall, resulting in damage to the ACB or personal injury.● When retracting the draw-out rail into the draw-out cradle, be sure to push the rail end. Do not hold the hook pin, body stopper, or body stopper shaft. Doing so may cause your fingers to be pinched, resulting in injury.● Do not forcibly turn the draw-out handle clockwise when the breaker body is in the CONN. Position. Doing so may cause a malfunction.● If the ACB has the breaker fixing bolts, make sure the bolts on both sides are securely tightened before using the ACB. Loosened fixing bolts may cause a malfunction of the ACB, in particular when it is installed in such an area that is subject to strong vibrations.

Use the separate draw-out handle to insert the breaker body.

4-2-3-1. Putting the breaker body back to the ISOLATED position

- 1) Make sure the draw-out cradle (Fig. 26 7) is secured with mounting screws.
- 2) Push the rail stoppers (Fig. 26 8) outward on both sides of the draw-out cradle to unlock the draw-out rail (Fig. 26 9), and then uphold and pull out the rail until it stops. The draw-out rail will be locked again by the stoppers. (The breaker body (Fig. 26 3)

cannot be inserted unless the rail is locked).

- 3) Use an optional lifter or lifting plate to place the breaker body rollers (Fig. 27) on the draw-out rail (Fig. 27).
 - Do not leave the ACB body on the draw-out rail pulled out.
- 4) Make sure the breaker fixing bolts (Fig. 26 2), if fitted, are loosened and not arrest the breaker body.
- 5) Make sure the hand connector (Fig. 26 15) of the communication terminal block, if fitted, is so positioned that it does not get caught between the breaker body and the draw-out cradle.
- 6) If the ACB has the breaker fixing bolts (Fig. 26 2), make sure the bolts are loosened and, holding both the grips (Fig. 26 10), firmly push the breaker body into the draw-out cradle.
 - If the ACB is equipped with the communication terminal block, plug the hand connector (Fig. 26 15) into the communication terminal block while pushing the breaker body into the draw-out cradle. Make sure the hand connector and control wire of the ACB are not snagged when pushing the breaker body into the draw-out cradle.
- 7) Push the rail stoppers (Fig. 26 8) outward on both sides of the draw-out cradle (Fig. 26 12) to unlock the draw-out rail, and then push the rail ends to insert the rail until it stops. The draw-out rail will be locked again by the stoppers.

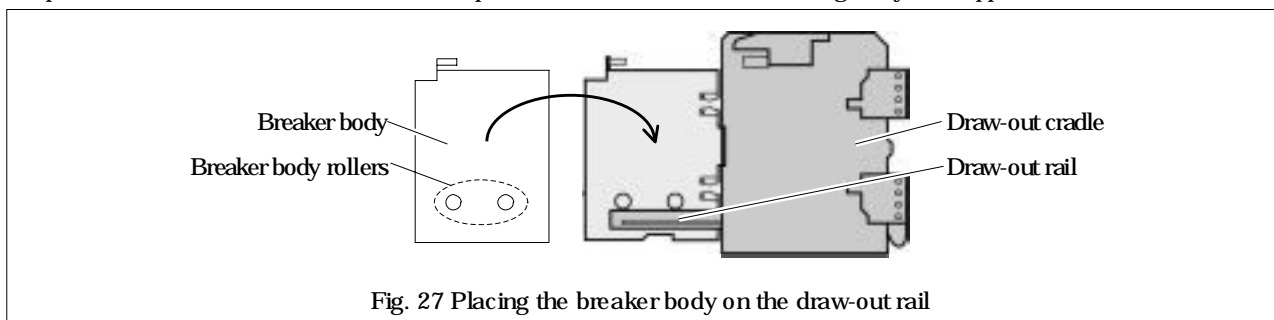

Fig. 27 Placing the breaker body on the draw-out rail

4-2-3-2. Moving the breaker body from the ISOLATED position to the TEST position

- 1) Make sure the ON-OFF indicator (Fig. 26 13) shows “OFF”. (If the ACB remains closed, the draw-out handle (Fig. 26 1) cannot be inserted).
- 2) Unlock the position lock lever (Fig. 26 14) if locked. See section 4-5.
- 3) Insert the draw-out handle into the draw-out handle insertion hole (Fig. 26 4) and slowly turn clockwise until the position indicator (Fig. 26 5) shows “TEST”.
 - The ACB cannot be closed as long as the draw-out handle is in the draw-out handle insertion hole. To close the ACB e.g., for ON-OFF testing, remove the draw-out handle.

4-2-3-3. Moving the breaker body from the TEST position to the CONN. position

- 1) Open the ACB. (If the ACB remains closed, the draw-out handle (Fig. 26 1) cannot be inserted).
- 2) Unlock the position lock lever (Fig. 26 14) if locked. See section 4-5.
- 3) Press the release button (Fig. 26 6). The release button will be locked depressed.
- 4) Insert the draw-out handle into the draw-out handle insertion hole (Fig. 26 4) and turn clockwise until the position indicator (Fig. 26 5) shows “CONN.” and the handle cannot be turned with its max. operating torque (14.7 N·m).

Turning the draw-out handle will unlock the release button.

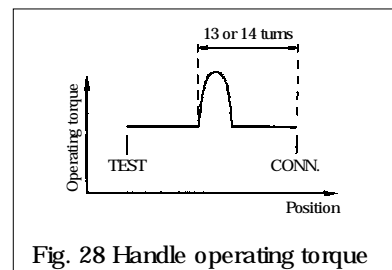

Fig. 28 Handle operating torque

- When the main contact starts engaging, the force required to turn the handle will increase as shown in Fig. 28. This symptom does not mean a malfunction. Continue to turn the handle. Rotating the handle more 13 or 14 turns moves the breaker body to the CONN. position, where the handle cannot be turned with its max. operating torque.
- 5) Remove the draw-out handle.
 - 6) Tighten the breaker fixing bolts (Fig. 26 2), if used, to lock the breaker body.

4-2-4. Contact status of auxiliary and position switches

Tables 17 and 18 show the contact status of auxiliary switches and position switches respectively.

Table 17-1 Contact status of auxiliary switches

Breaker body position \ ACB state	ON	OFF	Status of a-contact	Status of b-contact
	CONN.	High	Low	ON
TEST	High	Low	ON	OFF
ISOLATED	High	Low	ON	OFF
Removed	High	Low	ON	OFF
	Low	High	OFF	ON

Table 17-2 Contact status of auxiliary switches (When pursuant to ship classification society rules)

Breaker body position \ ACB state	ON	OFF	Status of a-contact	Status of b-contact
	CONN.	High	Low	ON
TEST	High	Low	ON	OFF
ISOLATED	High	Low	ON	OFF
Removed	High	Low	ON	OFF
	Low	High	OFF	ON

Table 18 Contact statuses of position switches

Switch \ Position indication	ISOLATED	TEST	CONN.	Status of a-contact	Status of b-contact
	CONN. position indication	Low	Low	High	ON
TEST position indication	Low	High	Low	ON	OFF
ISOLATED position indication	High	Low	Low	ON	OFF
Inserted position indication *	High	Low	Low	ON	OFF
	Low	Low	High	OFF	ON

* "Inserted" means that the breaker body is in the CONN., TEST, or ISOLATED position.

4-3. ON-OFF Button Cover Locking Procedure

Lock the button cover using a padlock with $\phi 6$ shackle (up to 3 padlocks can be used) as shown in Fig. 29. The ON-OFF button cover is locked and the ON and OFF buttons cannot be operated.

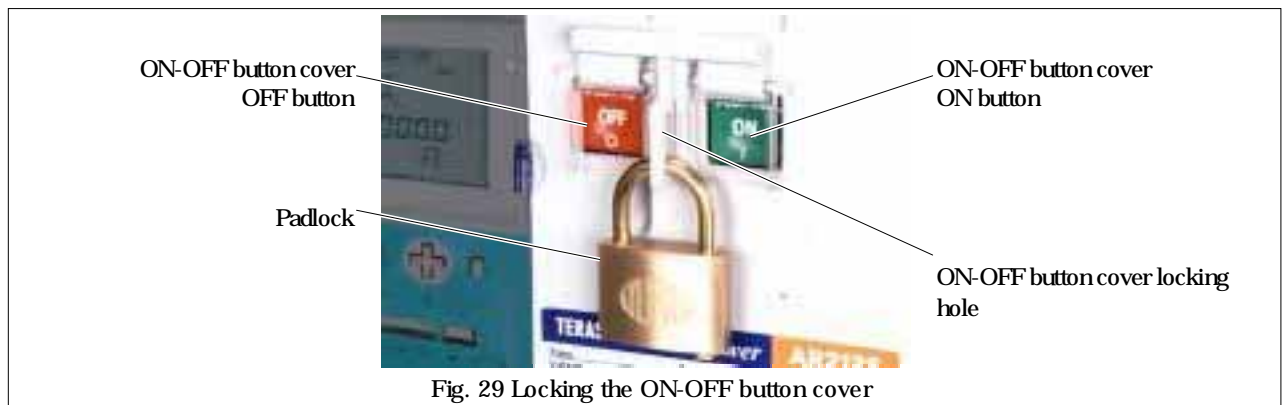

Fig. 29 Locking the ON-OFF button cover

4-4. Lock in OFF Procedure

- 1) Open the OFF button cover shown in Fig. 30.
- 2) Raise the OFF-lock tab and close the button cover:
- 3) Lock the button cover using a padlock with $\phi 6$ shackle (up to 3 padlocks can be used) as shown in Fig. 30. The OFF button is locked depressed, which disables the ON button.



4-5. Position Lock Lever Locking Procedure

- 1) Move the breaker body to the desired position (CONN, TEST or ISOLATED).
- 2) Pull out the position lock lever shown in Fig. 31.
- 3) Lock the position padlock lever using a padlock with $\phi 6$ shackle (up to 3 padlocks can be used) as shown in Fig. 31. This prevents the draw-out handle from being inserted into the draw-out handle insertion hole, i.e., the breaker position cannot be changed.

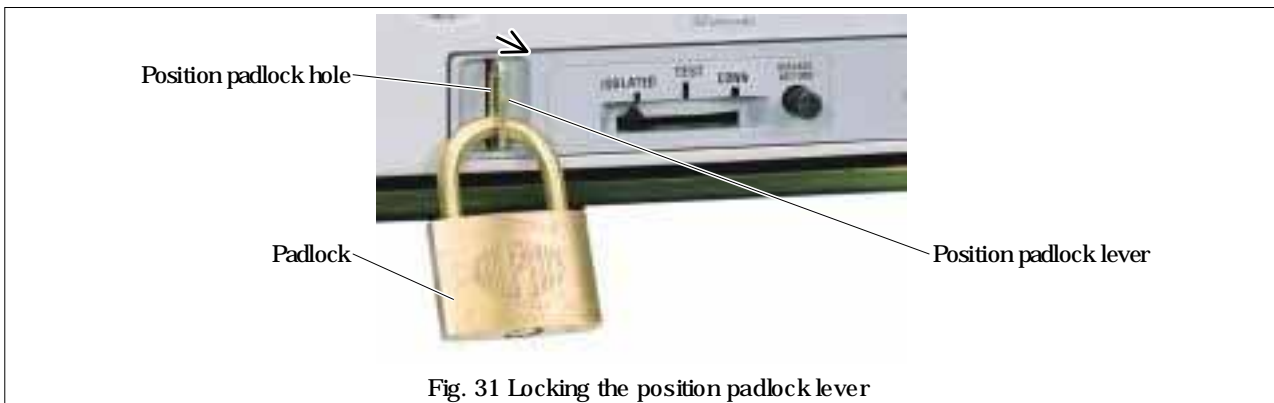

4-6. Breaker Fixing Bolt Securing Procedure

- 1) Move the breaker body to the CONN. position.
- 2) Loosen the breaker fixing bolt shown in Fig. 32, move the spring and flat washers close to the bolt head and push the bolt into the U-notch of the grip.
- 3) Tighten the breaker fixing bolt using the draw-out handle. This procedure is required for both the sides of the ACB.

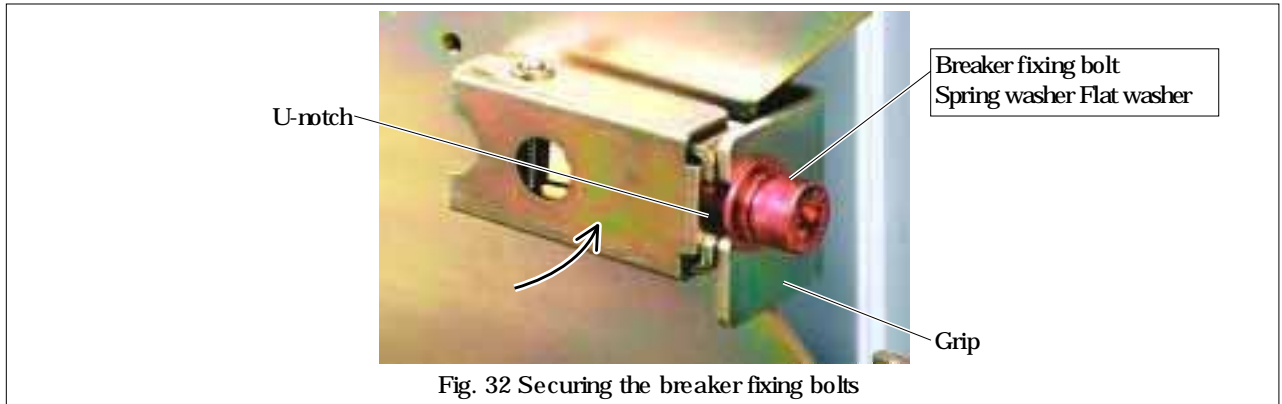

4-7. OCR Cover Locking Procedure

Lock the OCR cover using a padlock with $\phi 6$ shackle as shown in Fig. 33. The OCR cover cannot be opened, which prevents OCR settings from being changed.

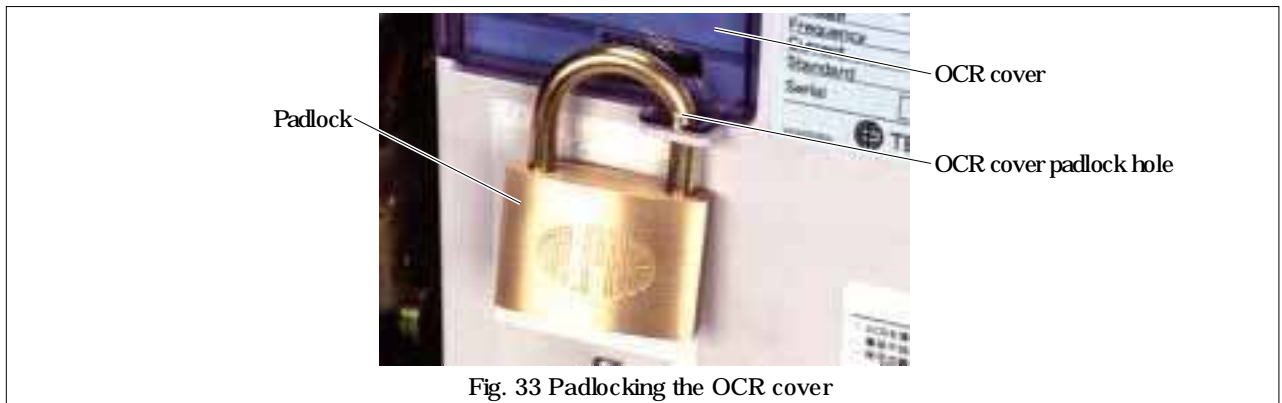

5. OVERCURRENT RELEASE (OCR)

Options available for the type AR ACBs include a highly reliable, multi-functional overcurrent release (OCR) with a built-in 16-bit microprocessor:

This OCR is supplied with power through a CT and main circuit current signals from current sensors. When the OCR detects a fault, it sends a trip signal to the magnet hold trigger (MHT) or provides a trip indication or an alarm depending on the type of the fault. The OCR uses the root mean square sensing for the long time delay (LT), pre-trip alarm (PTA, PTA2), and N-phase protection (NP) functions. (When six times the CT rated primary current is exceeded, the peak value sensing is used instead.) If a harmonic current flows through the ACB continuously, the root mean square sensing allows the ACB to operate normally.

The OCR is available in the type that follows:

- AGR-21BL L characteristic for general feeder (for works and transformer protection)
- AGR-21BR R characteristic for general feeder (3 characteristics conforming to IEC60255)
- AGR-21BS,22BS S characteristic for generator protection

5-1. Specifications

Specifications of the OCR are shown in Table 19.

Table 19 Specifications of type AGR-21B, 22B OCR (●: Standard, ○: Optional, -: Not applicable)

Application		For general feeder				For generator protection		Reference section
		L		R		S		
Type designation		AGR-21BL-XX		AGR-21BR-XX		AGR-XXXX-XX		
Suffix (XX or XXXX) of type designation		PS	PG	PS	PG	21BS-PS	22BS-PR	
Protective function	Long time delay trip (LT), short time delay trip (ST) and instantaneous trip (INST/MCR) ¹	●	●	●	●	●	●	5-2., 5-3-6.
	Ground fault trip (GF) ^{2 3}	-	●	-	●	-	-	5-2., 5-3-7.
	Reverse power trip (RPT) ^{2 4 5}	-	-	-	-	-	●	5-2., 5-3-6.
	N-phase protection (NP) ^{1 6}	○	○	○	○	-	-	5-2., 5-3-6.
	Negative-phase sequence protection (NP) ^{2 7}	○	○	○	○	-	-	5-2., 5-3-7.
	Line side ground fault protection (REF) ^{2 3 8 9}	-	○	-	○	-	-	5-2., 5-3-7.
	Contact overheat monitoring (OH) ^{2 9 10}	-	-	-	-	-	○	3-3.
Zone interlock (Z) ^{9 11}	-	-	-	-	-	○	3-3.	
Alarm function	Pretrip alarm (PTA) ^{9 12 13}	●	●	●	●	●	●	5-2., 5-3-7.
	Pretrip alarm 2 (PTA2) ^{9 12 13}	-	-	-	-	-	○	5-2., 5-3-7.
	Undervoltage alarm (UV) ^{5 9 12 14}	-	-	-	-	-	○	5-2., 5-3-6.
Protection characteristic	COLD/HOT (LT) ¹⁵	●	●	-	-	-	-	5-2., 5-3-6.
	Ft ON/OFF (ST) ¹⁶	●	●	●	●	●	●	5-2., 5-3-7.
	INST/MCR (Instantaneous trip) ¹⁷	●	●	●	●	●	●	5-3-4.
	$I^{0.02}t/I^t/F^t/P^t$ (LT) ¹⁸	-	-	●	●	-	-	5-3-4.
	Ft ON/OFF (FC) ¹⁶	-	●	-	●	-	-	5-3-4.
Polarity NOR/REV (RPT) ¹⁹	-	-	-	-	-	●	5-5.	
Operation indication	Indication on LCD and contact output (individual indication) ⁹	●	●	●	●	●	●	5-5.
Measurement/ event indication	Present current (switchable between respective phase current and max. phase current) ⁹	●	●	●	●	●	●	5-3-3.
	Max. current (max. phase current) ⁹	●	●	●	●	●	●	5-3-3.
	Trip event log (last trip event) ^{9 20}	●	●	●	●	●	●	5-3-8.
	Alarm event log (last alarm event) ^{9 20}	●	●	●	●	●	●	5-3-8.
Communication Functions	○	○	○	○	○	○	3-3.	
External indicator	-	-	-	-	-	○	-	
Test function ^{9 21}	●	●	●	●	●	●	5-4.	
Control power supply ²²	Required	Required	Required	Required	Required	Required	3-3.	

1 Two modes are available; one where the ACB is tripped open and operation indication is provided and the other where the ACB is not tripped and no operation indication is provided. Fail-safe against failure in setup (see 5-2).

2 Three modes are available; the first where the ACB is tripped open and operation indication is provided, the second where the ACB is not tripped and only operation indication is provided, and the third where the ACB is not tripped open and no operation indication is provided.

3 Residual current sensing. When a 3-pole ACB applies to a 3-phase, 4-wire circuit, be sure to use the separate N-phase protection CT (see 3-3).

4 Allows 3-phase generators operated in parallel to be protected against reverse power.

5 If the main circuit voltage exceeds AC250V, a step-down PT (potential transformer) is needed.

6 Provides protection to the neutral conductor in a 3-phase, 4-wire circuit against overcurrent. This function applies to a 4-pole ACB.

7 Provides protection to ACBs against negative-phase current caused by phase loss or reverse phase, preventing damage to loads.

8 The line side ground fault protection capability allows the ACB to trip open when transformer windings or cables on the line side suffers a ground fault in TN-C or TN-S power distribution systems where the line side neutral is grounded.

9 Control power supply is required. Disabled when control power is lost.

10 Protects the breaker main contact against overheat, preventing troubles caused by thermal damage of the contact. Helpful for preventive maintenance.

11 Zone selective interlock implemented between ACBs in a hierarchical system allows the upstream ACB nearest a fault point to trip open in a minimum time, irrespective of short time delay trip or ground fault trip pickup timing, thereby minimizing thermal or mechanical damage to loads. This stands for selective discrimination with zero timing.

12 Two modes are available; one where operation indication is provided and the other where no operation indication is provided.

13 The pretrip alarm capability provides an alarm on the LCD and delivers contact output when it is detected that the current value exceeds the current setting for longer than the time setting, thereby preventing the ACB from tripping due to a gradual increase in load current. Pretrip alarm 2 allows two different timings to be set and helps regulate loads depending on their importance.

14 Provides an alarm on the LCD and delivers contact output when the voltage of the main circuit becomes low.

15 In HOT mode, the OCR is actuated in shorter time than in COLD mode when an overload occurs after a certain degree of load is maintained for a certain time of period. This mode helps protect heat sensitive loads.

16 Ft ON avoids intersection of characteristic curves of the ACB and e.g., a downstream fuse. This will improve selective discrimination flexibility.

17 INST is enabled, the OCR trips open the ACB when the trip pickup current is reached or exceeded, irrespective of the ACB status. When MCR is enabled, the OCR trips open the ACB when the ACB making current setting is reached or exceeded, and after tripping operation, it locks the ACB in the open state. MCR provides the INST function if the control power is lost.

18 Helpful for protection in coordination with fuses or the like. (IEC 60255-3)

19 Allows selection of the power supply terminal position between upstream and downstream of the breaker.

20 Logs the latest trip event and alarm event and allows displaying the cause, fault current value and operating time of the events.

21 Allows simplified field testing where simulation signals from/to the OCR are used to check for normal long time delay, short time delay, instantaneous and ground fault trip functions.

22 If the control power is lost, the long time delay trip, short time delay trip, instantaneous trip, ground fault trip, reverse power trip, N-phase protection and negative-phase sequence protection functions are alive.

5-2. Characteristics

5-2-1. L characteristic for general feeder

Characteristic settings and characteristic curves of the type AGR-11BL OCR (with L characteristic) are shown in Table 20 and Fig. 34-36 respectively.

Table 20 Settings of type AGR-21BL OCR (with L characteristic)

Setting item		Symbol	Setting range										
Rated current ²		I _n	CT rated primary current [I _{CT}] × (0.5-0.63-0.8-1.0) (A)										
			Applied [I _{CT}] (A)										
			Rated current [I _n] (A)	[I _{CT}] × 0.5	100	200	400	630	800	1000	1250	1600	2000
				[I _{CT}] × 0.63	125	250	500	800	1000	1250	1600	2000	2500
[I _{CT}] × 0.8	160	320	630	1000	1250	1600	2000	2500	3200				
[I _{CT}] × 1.0	200	400	800	1250	1600	2000	2500	3200	4000				
Long time delay trip (LT) ³	pickup current (continuous)	I _R	[I _n] × (0.8-0.85-0.9-0.95-1.0-NON) (A) ⁴										
	trip timing	t _R	(0.5-1.25-2.5-5-10-15-20-25-30) (sec) at 600% of [I _R], Tolerance: ±15%, +0.15s -0s										
	INST/MCR	-	COLD/HOT ⁶										
Short time delay trip (ST) ⁷	pickup current	I _{sd}	[I _n] × (1-1.5-2-2.5-3-4-6-8-10-NON) (A), Tolerance: ±15% ⁴										
	trip timing	t _{sd}	Relaying time (ms.)	50	100	200	400	600	800				
		Resettable time (ms.)	25	75	175	375	575	775					
	Pt mode	Pt t _{sd}	Max. total clearing time (ms.)	120	170	270	470	670	870				
Instantaneous trip (INST/MCR)	pickup current	I _i	[I _n] × (2-4-6-8-10-12-14-16-NON) (A), Tolerance: ±20% ⁴										
	INST/MCR	-	INST/MCR										
Ground fault trip (GF)	pickup current ⁹	I _g	[I _{CT}] × (0.1-0.2-0.3-0.4-0.6-0.8-1.0-NON) (A), Tolerance: ±20% ⁴										
	trip timing	t _g	Relaying time (ms.)	100	200	300	500	1000	2000				
		Resettable time (ms.)	75	175	275	475	975	1975					
	Pt mode	Pt t _g	Max. total clearing time (ms.)	170	270	370	570	1070	2070				
Mode	-	TRIP/AL/OFF ¹⁰											
N-phase protection trip (NP) ³	pickup current (continuous)	I _N	[I _{CT}] × (0.4-0.5-0.63-0.8-1.0)										
	trip timing	t _R	• Non tripping at not more than [I _N] × 1.05, Tripping at more than [I _N] × 1.05 and not more than [I _N] × 1.2 ⁵										
	HOT/COLD	-	Depends on the long time delay trip mode (HOT/COLD). ⁶										
Negative-phase sequence protection (NS) ¹¹	Current setting	I _{NS}	[I _n] × (0.2-0.3-0.4-0.5-0.6-0.7-0.8-0.9-1.0) (A), Tolerance: ±10%										
	Time setting	t _{NS}	(0.4-0.8-1.2-1.6-2.2-2.4-2.8-3.2-3.6-4) (sec) at 150% of [I _{NS}], Tolerance: ±20%, +0.15 s -0 s										
	Mode	-	TRIP/AL/OFF ¹⁰										
Line side ground fault protection (REF)	Current setting	I _{REF}	[I _{CT}] × (0.1-0.2-0.3-0.4-0.6-0.8-1.0-NON) (A), Tolerance: ±20% ⁴										
	Line side ground fault protection bias current	I _{REF2}	[I _{CT}] × (0.1-0.2-0.3-0.5-0.7-0.9-1.1-1.3-1.5) (A), Tolerance: ±20%										
	Time setting	-	Instantaneous										
	Mode	-	TRIP/AL/OFF ¹⁰										
Pretrip alarm (PTA)	Current setting	I _{P1}	[I _n] × (0.75-0.8-0.85-0.9-0.95-1.0) (A), Tolerance: ±7.5%										
	Time setting	t _{P1}	(5-10-15-20-40-60-80-120-160-200) (sec) at not less than [I _{P1}], Tolerance: ±15%, +0.1s -0 s										
	Mode	-	AL/OFF ¹²										

1 Underlined values are default settings.

2 A change in rated current setting results in changes in long time delay trip, short time delay trip, instantaneous trip, pretrip alarm and negative-phase sequence protection trip pickup current settings accordingly.

3 The operating time (t) at a long time delay (or N-phase protection) trip pickup current setting is given by

$$t = -27.94 \times t_r \times \log_e \{ 1 - (1.125 I_R / i)^2 \} \pm 15\% + 0.15 - 0 \text{ [sec]}$$

(I_R: Long time delay or N-phase protection trip pickup current setting, i: Overcurrent value, t_r: Time setting)

4 NON setting disables protective functions. If the short time delay trip function and the instantaneous trip (or MCR) function are both attempted to be set to NON, however, the fail-safe operates so that

- When the short time delay trip function has been set to NON, the instantaneous trip function cannot be set to NON or MCR.
- When the instantaneous trip function is set to NON or MCR, the short time delay trip function cannot be set to NON.

5 A pickup current means the threshold by which the OCR determines whether or not an overcurrent occurs. When the current flowing through the OCR exceeds the pickup current setting provided that [I_n] × 1.05 < pickup current setting ≤ [I_n] × 1.2, the OCR starts counting the time for tripping. Once the current flowing through the OCR reduces to less than the pickup current setting, time count is reset.

6 In HOT mode, the OCR is actuated in shorter time than in COLD mode when an overload occurs after a certain degree of load is maintained for a certain time of period. The OCR is factory set to COLD mode. See 5-3-6 for how to set the OCR to HOT mode. If the control power is lost, load data stored in HOT mode is cleared. Fig. 34 shows the operating time in COLD and HOT modes.

7 The short time delay trip function has precedence over the long time delay trip function. The OCR operates at the short time delay trip timing even in those current ranges in which the long time delay trip time setting is shorter than the short time delay time setting.

8 Fig. 35 shows the operating characteristic at P_t ON and P_t OFF. When P_t is ON, the OCR operates at fixed trip pickup current of 1000% (100% for ground fault trip) of [I_n].

9 The ground fault trip pickup current setting should not exceed 1200A.

10 "TRIP" means the breaker is tripped open and operation indication is provided, "AL" means the breaker is not tripped and only operation indication is provided, and "OFF" means the breaker is not tripped open and no operation indication is provided.

11 The operating time (t) at a negative-phase sequence protection trip pickup current setting is given by

$$t = 1.5 \times t_{NS} \times I_{NS} / i \pm 20\% + 0.15 - 0 \text{ [sec]}$$

(I_{NS}: Negative-phase sequence protection trip pickup current setting, i: Overcurrent value, t_{NS}: Time setting) (I_{NS} is fixed to I_n when I_{NS} > 3 X I_n)

12 "AL" means operation indication is provided and "OFF" means no operation indication is provided.

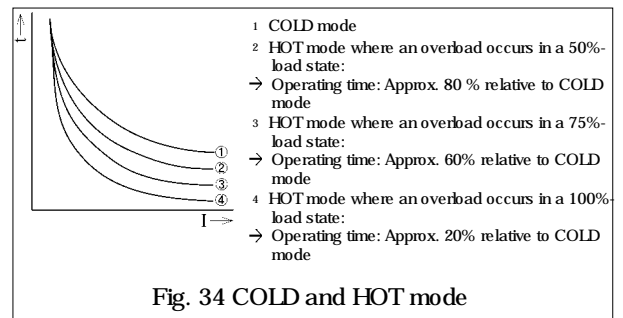

Fig. 34 COLD and HOT mode

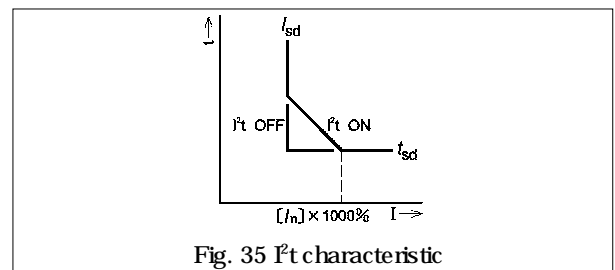
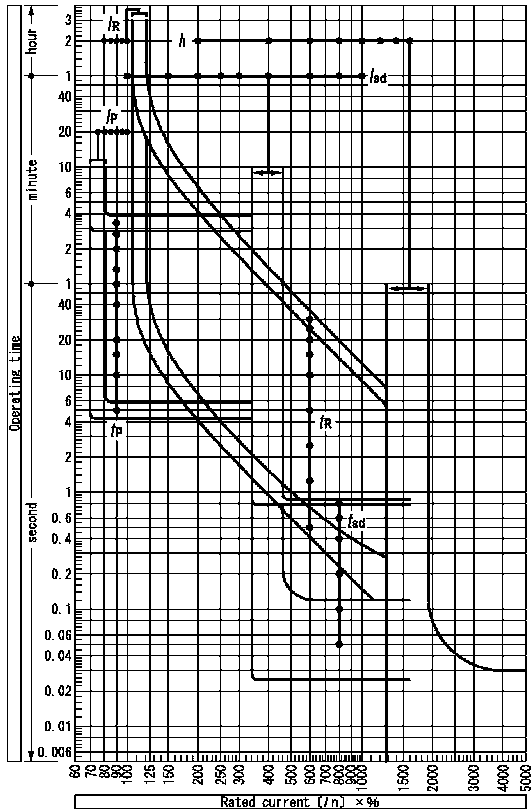
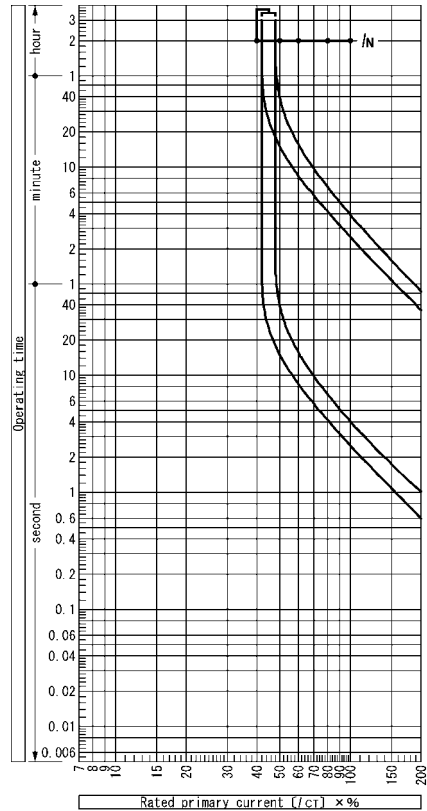

Fig. 35 P_t characteristic



Long time delay trip, Short time delay trip, Instantaneous trip and Pre-trip alarm



N-phase protection trip

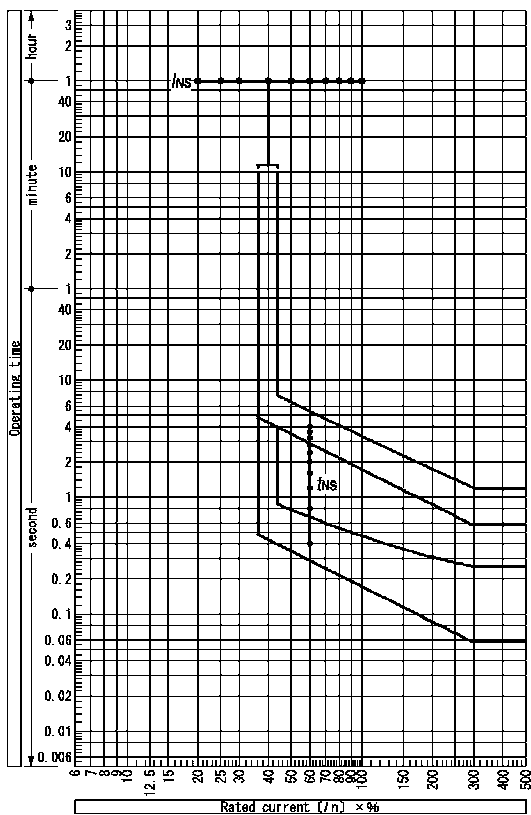

Negative-phase sequence protection

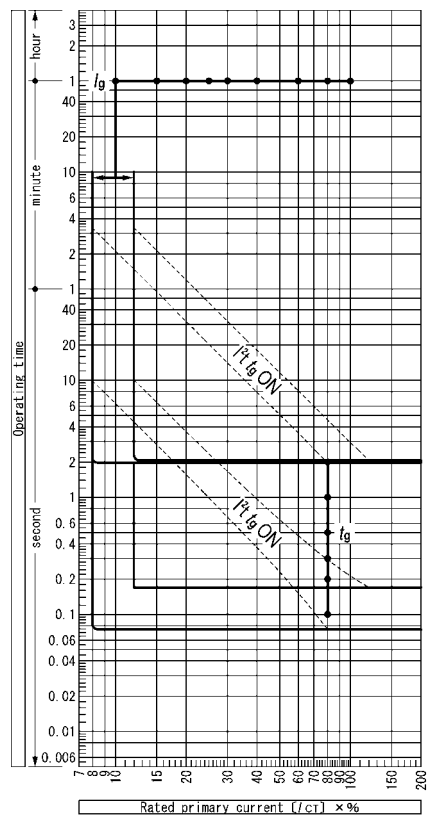

Ground fault trip

Fig. 36 Characteristic curves of type AGR-21BL OCR (with L characteristic)

5-2-2. R characteristic for general feeder

Characteristic settings and characteristic curves of the type AGR-21BR OCR (with R characteristic) are shown in Table 21 and Figs. 37 - 42 respectively.

Fig. 21 Characteristic settings of type AGR-21BR OCR (with R characteristic)

Setting item		Symbol	Setting range ¹									
Rated current ²		I _n	CT rated primary current [I _{CT}] × (0.5-0.63-0.8-1.0) (A)									
			Applied [I _{CT}] (A)									
	Rated current [I _n] (A)		[I _{CT}] × 0.5	100	200	400	630	800	1000	1250	1600	2000
			[I _{CT}] × 0.63	125	250	500	800	1000	1250	1600	2000	2500
		[I _{CT}] × 0.8	160	320	630	1000	1250	1600	2000	2500	3200	
		[I _{CT}] × 1.0	200	400	800	1250	1600	2000	2500	3200	4000	
Long time delay trip (LT) ³	Current setting (continuous energization)	I _R	[I _n] × (0.8-0.85-0.9-0.95-1.0-NON) (A), Tolerance: ±5% ⁴									
	Time setting	t _R	(1-2-3-4-5-6-3-6-8-10) (sec) at 300% of [I _R], Tolerance: ±20%, +0.15 s -0 s									
	Protection type	-	STF: F ^{0.02} t, VIT: I t, EIT: F t, 3IT: F t, 4IT: F t									
Short time delay trip (ST) ⁵	Current setting	I _d	[I _n] × (1-1.5-2-2.5-3-4-6-8-10-NON) (A), Tolerance: ±15% ⁴									
		t _{sd}	Relaying time (ms.)									
	Time setting		Resettable time (ms.)									
			Max. total clearing time (ms.)									
	F ^t protection type	F ^t t _{sd}	OFF/ON ⁶									
Instantaneous trip (INST/MCR)	Current setting	I	[I _n] × (2-4-6-8-10-12-14-16-NON) (A), Tolerance: ±20% ⁴									
		-	INST/MCR									
Ground fault trip (GF)	Current setting ⁷	I _g	[I _{CT}] × (0.1-0.2-0.3-0.4-0.6-0.8-1.0-NON) (A), Tolerance: ±20% ⁴									
		t _g	Relaying time (ms.)									
	Time setting		Resettable time (ms.)									
			Max. total clearing time (ms.)									
	F ^t protection type	F ^t t _g	OFF/ON ⁶									
	Mode	-	TRIP/AL/OFF ⁸									
N-phase protection (NP) ³	Current setting (continuous energization)	I _N	[I _{CT}] × (0.4-0.5-0.63-0.8-1.0-NON) (A), Tolerance: ±5%									
	Time setting	t _R	Depends on the long time delay trip pickup timing. Activated at 300% of [I _R].									
Negative-phase sequence protection (NS) ⁹	Current setting	I _{NS}	[I _n] × (0.2-0.3-0.4-0.5-0.6-0.7-0.8-0.9-1.0) (A), Tolerance: ±10%									
	Time setting	t _{NS}	(0.4-0.8-1.2-1.6-2.2-4-2.8-3.2-3.6-4) (sec) at 150% of [I _{NS}], Tolerance: ±20%, +0.15 s -0 s									
	Mode	-	TRIP/AL/OFF ⁸									
Line side ground fault protection (REF)	Current setting	I _{REF}	[I _{CT}] × (0.1-0.2-0.3-0.4-0.6-0.8-1.0-NON) (A), Tolerance: ±20% ⁴									
	Line side ground fault protection bias current	I _{REF2}	[I _{CT}] × (0.1-0.2-0.3-0.5-0.7-0.9-1.1-1.3-1.5) (A), Tolerance: ±20%									
	Time setting	-	Instantaneous									
	Mode	-	TRIP/AL/OFF ⁸									
Pretrip alarm (PTA)	Current setting	I _{P1}	[I _n] × (0.75-0.8-0.85-0.9-0.95-1.0) (A), Tolerance: ±7.5%									
	Time setting	t _{P1}	(5-10-15-20-40-60-80-120-160-200) (sec) at not less than [I _{P1}], Tolerance: ±15%, +0.1s -0 s									
	Mode	-	AL/OFF ¹⁰									

¹ Underlined values are default settings.

² A change in rated current setting results in changes in long time delay trip, short time delay trip, instantaneous trip, pretrip alarm and negative-phase sequence protection trip pickup current settings accordingly.

³ The operating time (t) at a long time delay (or N-phase protection) trip pickup current setting is given by

$$t = 0.2222 \times t_R / \{ (i/I_R)^{0.02} - 1 \} \pm 20\% + 0.15 - 0 \text{ [sec]} \text{ (I}^{0.02}\text{t protection type)}$$

$$t = 2 \times t_R / \{ (i/I_R) - 1 \} \pm 20\% + 0.15 - 0 \text{ [sec]} \text{ (It protection type)}$$

$$t = 8 \times t_R / \{ (i/I_R)^2 - 1 \} \pm 20\% + 0.15 - 0 \text{ [sec]} \text{ (I}^2\text{t protection type)}$$

$$t = 26 \times t_R / \{ (i/I_R)^3 - 1 \} \pm 20\% + 0.15 - 0 \text{ [sec]} \text{ (I}^3\text{t protection type)}$$

$$t = 80 \times t_R / \{ (i/I_R)^4 - 1 \} \pm 20\% + 0.15 - 0 \text{ [sec]} \text{ (I}^4\text{t protection type)}$$

(I_R: Long time delay or N-phase protection trip pickup current setting, i: Overcurrent value, t_R: Time setting)

⁴ NON setting disables protective functions. If the short time delay trip function and the instantaneous trip (or MCR) function are both attempted to be set to NON, however, the fail-safe operates so that:

- When the short time delay trip function has been set to NON, the instantaneous trip function cannot be set to NON or MCR.
- When the instantaneous trip function has been set to NON or MCR, the short time delay trip function cannot be set to NON.

⁵ The short time delay trip function has precedence over the long time delay trip function. The OCR operates at the short time delay trip timing even in those current ranges in which the long time delay trip time setting is shorter than the short time delay time setting.

⁶ Fig. 35 shows the operating characteristic at F ON and F OFF. When F^t is ON, the OCR operates at fixed trip pickup current of 1000% (100% for ground fault trip) of [I_n].

⁷ The ground fault trip pickup current setting should not exceed 1200A.

⁸ "TRIP" means the breaker is tripped open and operation indication is provided, "AL" means the breaker is not tripped and only operation indication is provided, and "OFF" means the breaker is not tripped open and no operation indication is provided.

⁹ The operating time (t) at a negative-phase sequence protection trip pickup current setting is given by

$$t = 1.5 \times t_{NS} \times I_{NS} / i \pm 20\% + 0.15 - 0 \text{ [sec]}$$

(I_{NS}: Negative-phase sequence protection trip pickup current setting, i: Overcurrent value, t_{NS}: Time setting)

(I_{NS} is fixed to I_n when I_{NS} > 3 X I_n)

¹⁰ "AL" means operation indication is provided and "OFF" means no operation indication is provided.

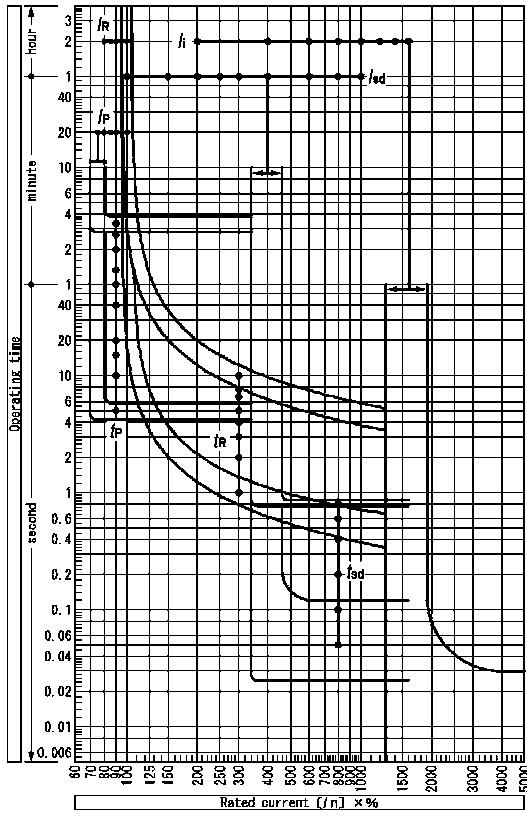

Long time delay trip, short time delay trip, instantaneous trip and pretrip alarm

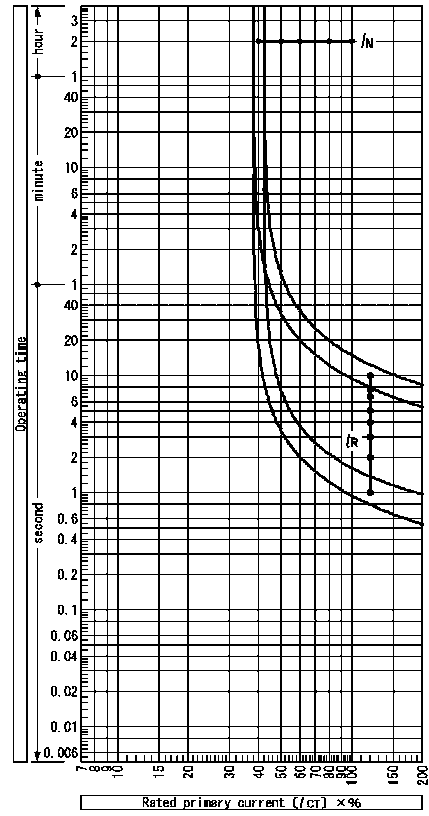

N-phase protection

Fig. 37 Characteristic curves of type AGR-21BR OCR (with R characteristic of $I^{0.02}t$ protection type)

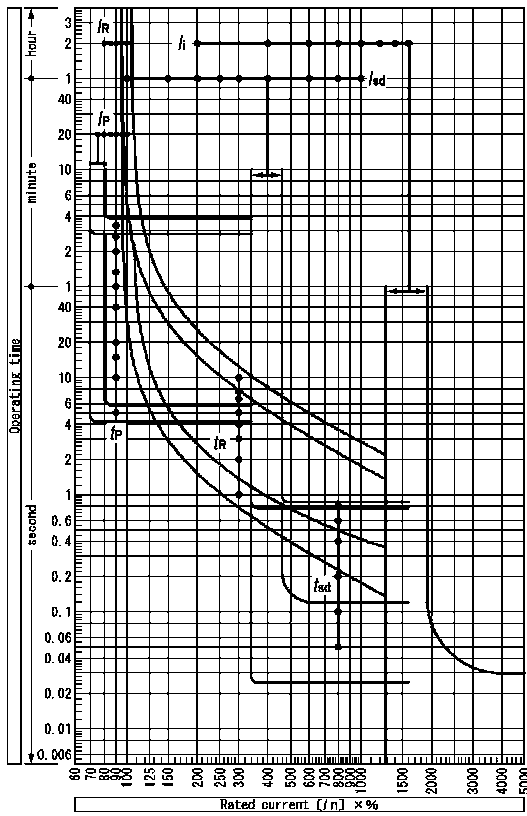

Long time delay trip, short time delay trip, instantaneous trip and pretrip alarm

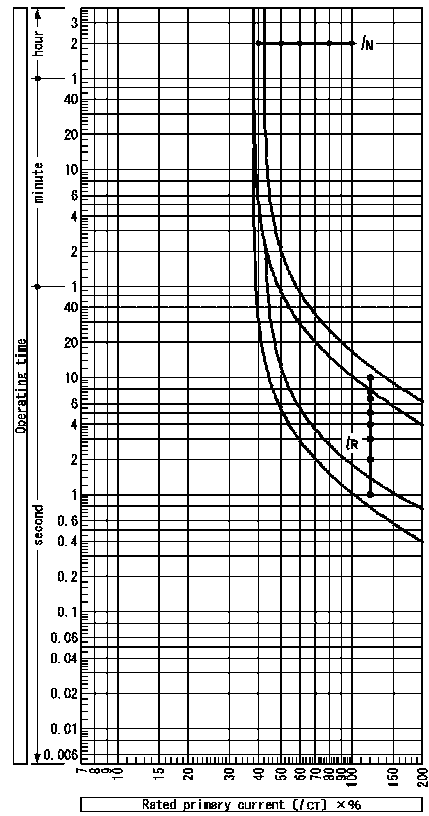

N-phase protection

Fig. 38 Characteristic curves of type AGR-21BR OCR (with R characteristic of I_t protection type)

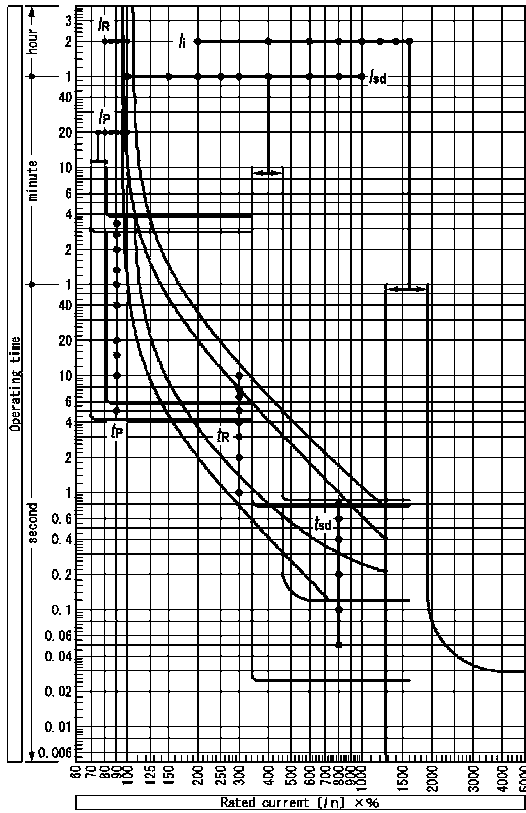

Long time delay tip, short time delay tip, instantaneous tip and pretrip alarm

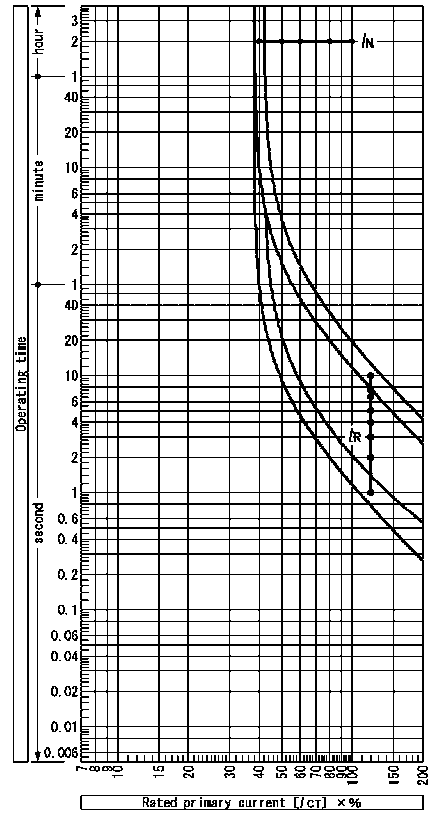

N-phase protection

Fig. 39 Characteristic curves of type AGR-21BR OCR (with R characteristic of P't protection type)

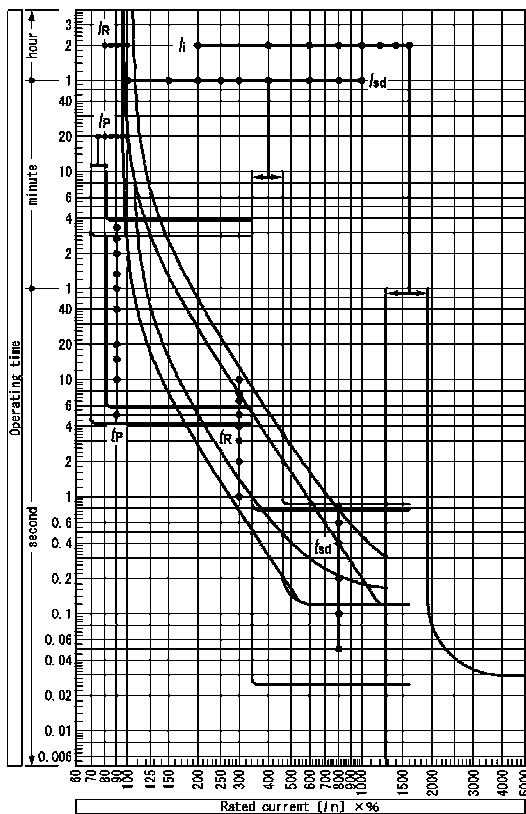

Long time delay tip, short time delay tip, instantaneous tip and pretrip alarm

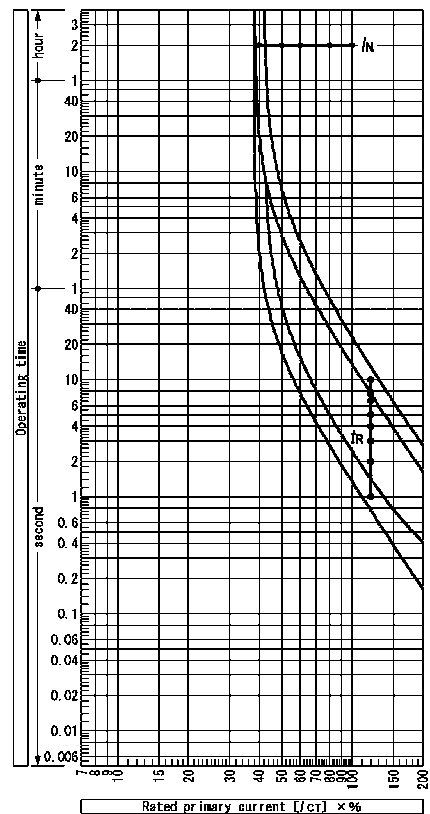

N-phase protection

Fig. 40 Characteristic curves of type AGR-21BR OCR (with R characteristic of P't protection type)

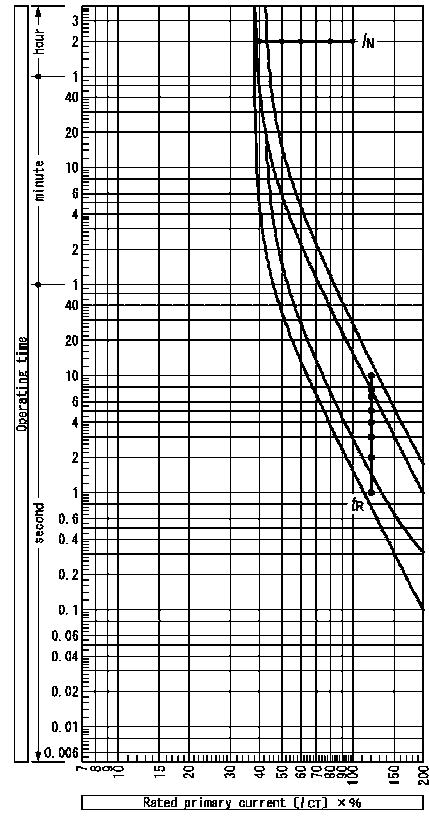
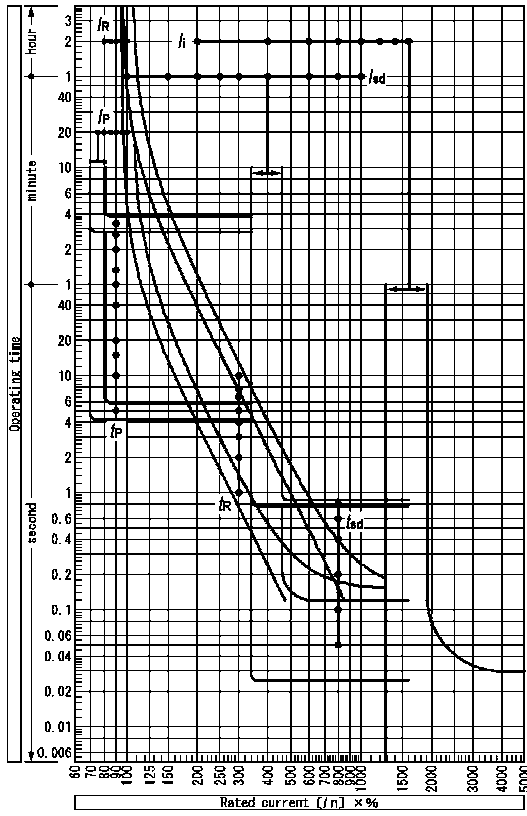

Long time delay trip, short time delay trip, instantaneous trip and pretrip alarm

N-phase protection

Fig. 41 Characteristic curves of type AGR-21BR OCR (with R characteristic of I^t protection type)

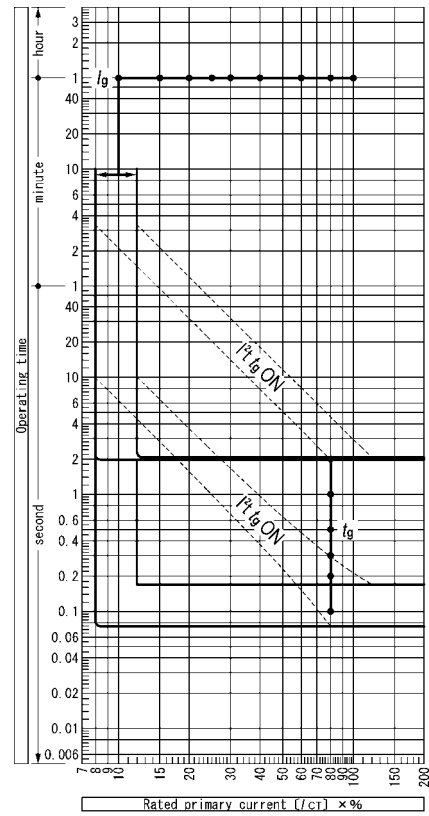
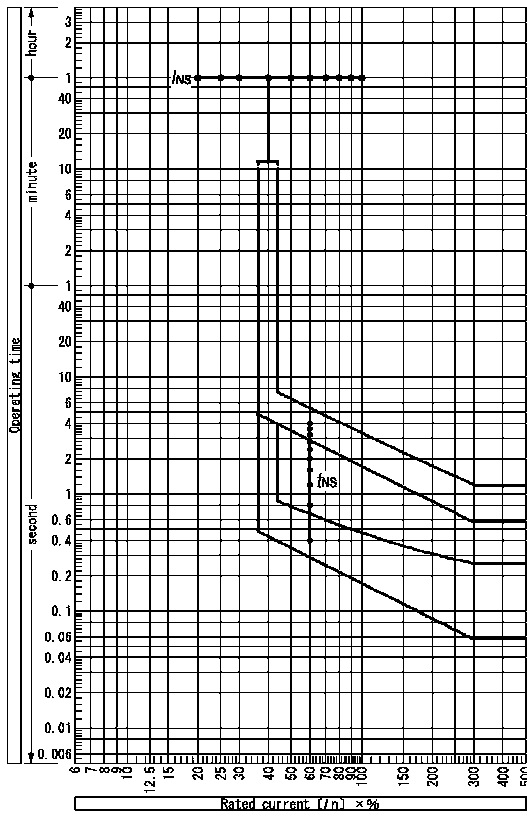

Negative-phase sequence protection

Ground fault trip

Fig. 42 Characteristic curves of type AGR-21BR OCR (with R characteristic of common protection type)

5-2-3. S characteristic for generator protection

Characteristic settings and characteristic curves of the type AGR-21BS/22BS OCR (with S characteristic) are shown in Table 22 and Figs. 43 and 44 respectively.

Fig. 22 Characteristic settings of type AGR-21BS/22BS OCR (with S characteristic)

Setting item		Symbol	Setting range ¹						
Rated current ²		I_n	CT rated primary current [I_{CT}] × (0.5 to 1.0) (A); Fixed to a single point						
Long time delay trip (LT) ³	Current setting (continuous energization)	I_R	$[I_n] \times (0.8-1.0-1.05-1.1-1.15-NON)$ (A), Tolerance: ±5% ⁴						
	Time setting	t_R	(15-20-25-30-40-50-60) (sec) at 120% of [I_R], Tolerance: ±15%, +0.15 s -0 s						
Short time delay trip (ST) ⁵	Current setting	I_{sd}	$[I_n] \times (2-2.5-2.7-3-3.5-4-4.5-5-NON)$ (A), Tolerance: ±10% ⁴						
	Time setting ⁶	t_{sd}	Relaying time (ms.)	100	<u>200</u>	300	400	600	800
		-	Resettable time (ms.)	75	175	275	375	575	775
	-	t_{td}	Max. total clearing time (ms.)	170	270	370	470	670	870
Instantaneous trip (INST/MCR)	Current setting	I	$[I_n] \times (2-4-6-8-10-12-14-16-NON)$ (A), Tolerance: ±20% ⁴						
	INST/MCR	-	INST/MCR						
Reverse power trip (RPT) ⁸	Power setting	P_R	$[P_n] \times (0.04-0.05-0.06-0.07-0.08-0.09-0.1-NON)$ (kW), Tolerance: +0% -20% ⁴						
	Time setting	-	(2.5-5-7.5-10-12.5-15-17.5-20) (sec) at 100% of [P_R], Tolerance: ±20%						
	Polarity	-	NOR/REV ⁹						
	Mode	-	TRIP/AL/OFF ¹⁰						
Contact overheat monitoring (OH)	Temperature setting	-	155°C						
	Time setting	-	Instantaneous						
	Mode	-	TRIP/AL/OFF ¹⁰						
Zone interlock (Z) ¹¹	Current setting	-	Short time delay trip and/or ground fault trip pickup current						
	Time setting	-	50 ms. or less						
Pretrip alam (PTA)	Current setting	I_{P1}	$[I_n] \times (0.75-0.8-0.85-0.9-0.95-1.0-1.05)$ (A), Tolerance: ±5%						
	Time setting	t_{P1}	(10-15-20-25-30) (sec) at 120% of [I_{P1}], Tolerance: ±15%, +0.1s -0s						
	Mode	-	AL/OFF ¹²						
Pretrip alam (PTA2)	Current setting	I_{P2}	$[I_n] \times (0.75-0.8-0.85-0.9-0.95-1.0-1.05)$ (A), Tolerance: ±5%						
	Time setting	t_{P2}	(1.5 × t_{P1}) (sec) at 120% of [I_{P2}], Tolerance: ±15%, +0.1s -0s						
	Mode	-	AL/OFF ¹²						
Undervoltage alam ^{13 14}	Voltage setting	-	$[V_n] \times (0.4-0.6-0.8)$ (V), Tolerance: ±5%						
	Time setting	-	(0.1-0.5-1-2-5-10-15-20-30-36) (sec) at voltage setting or less, Tolerance: +0.15 s -0.025 s						
	Recovery voltage setting ¹⁵	-	$[V_c] \times (0.8-0.85-0.9-0.95)$ (V), Tolerance: ±5%						
	Mode	-	AL/OFF ¹²						

- 1 Underlined values are default settings.
- 2 Cannot be changed by the user.
- 3 The operating time (t) at a long time delay trip (or pretrip alam) pickup current setting is given by

$$t = 1.44 \times t_R \times (I_R/i)^2 \pm 15\% + 0.15 - 0 \text{ [sec]}$$

(I_R : Long time delay trip or pretrip alam pickup current setting,
i: Overcurrent value, t_R : Time setting)

- 4 NON setting disables protective functions. If the short time delay trip function and the instantaneous trip (or MCR) function are both attempted to be set to NON, however, the fail-safe operates so that:
 - When the short time delay trip function has been set to NON, the instantaneous trip function cannot be set to NON or MCR.
 - When the instantaneous trip function has been set to NON or MCR, the short time delay trip function cannot be set to NON.
- 5 The short time delay trip function has precedence over the long time delay trip function. The OCR operates at the short time delay trip timing even in those current ranges in which the long time delay trip time setting is shorter than the short time delay time setting.
- 6 If DC24V zone interlock power is not provided between ³³ and ³⁴, the max. total clearing time is 50 msec, irrespective of the time setting.
- 7 Fig. 43 shows the operating characteristic at Ft ON and Ft OFF. When Ft is ON, the OCR operates at fixed trip pickup current of 500% of [I_n].
- 8 The operating time (t) at a reverse power trip pickup current setting is given by

$$t = 0.111 \times t_{RP} / \{ (P/0.9P_R) - 1 \} \pm 20 \text{ [sec]}$$

(P_R : Reverse power trip pickup current setting, P: Reverse power value,
 t_{RP} : Time setting)

- 9 Select NOR when the power supply of the load is upstream of the breaker and REV when it is downstream of the breaker. (See 5-3-4).
- 10 "TRIP" means the breaker is tripped open and operation indication is provided, "AL" means the breaker is not tripped and only operation indication is provided, and "OFF" means the breaker is not tripped open and no operation indication is provided.
- 11 Activated only when the fault point is within the zone covered by the breaker. If DC24V zone interlock power is not provided between ³³ and ³⁴, the zone interlock is inoperative and the short time delay trip function works with a total clearing time of 50 ms or less when a fault current is detected.
- 12 "AL" means operation indication is provided and "OFF" means no operation indication is provided.
- 13 Provides an alarm and delivers contact output when the voltage of the main circuit decreases to the voltage setting or lower for longer than the time setting. The alarm ceases when the main circuit voltage returns to the recovery voltage or higher.
- 14 When this capability is used in conjunction with the undervoltage trip device (UVD), an alarm may be provided after tripping operation of the breaker depending on the voltage setting.
- 15 The undervoltage alam capability does not work if the main circuit voltage is originally under the recovery voltage.

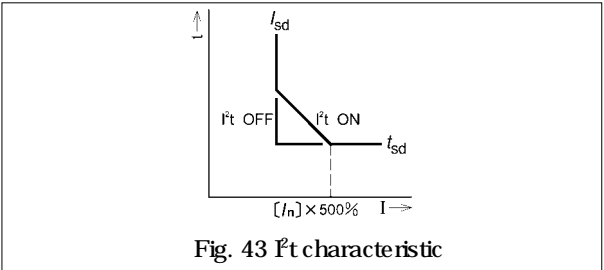
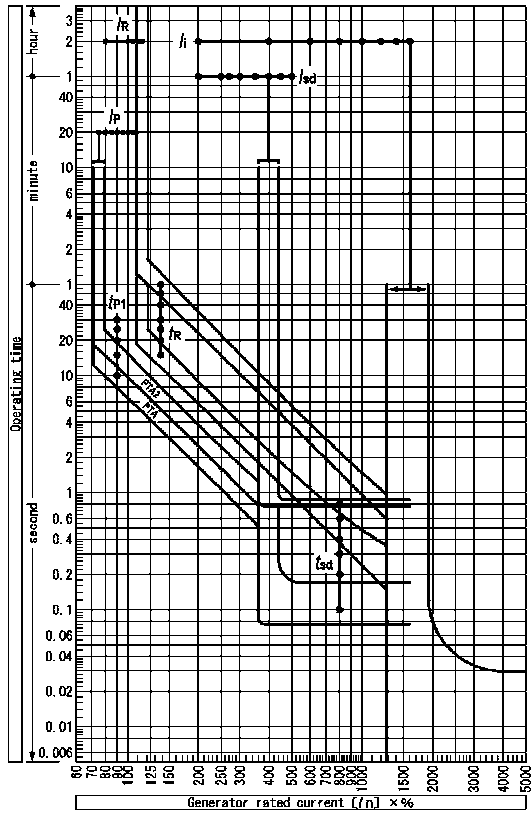
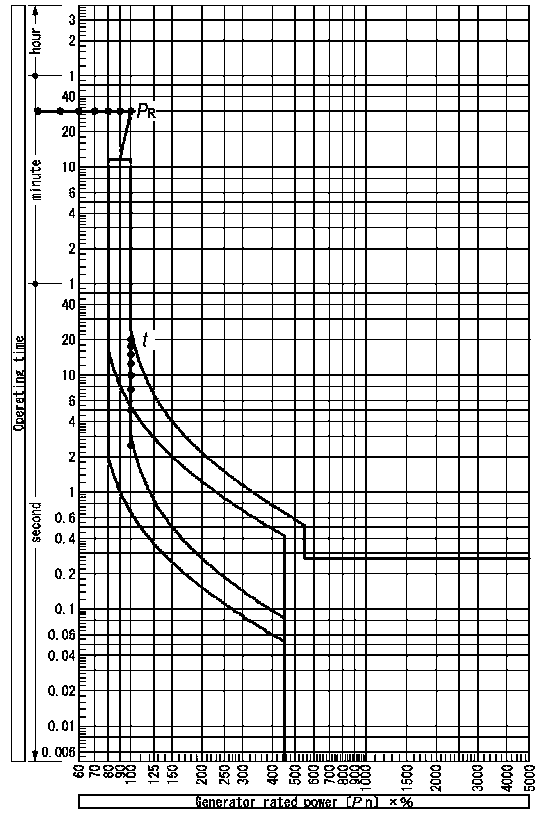

Fig. 43 Ft characteristic



Long time delay trip, short time delay trip, instantaneous trip and pretrip alarm



Reverse power trip

Fig. 44 Characteristic settings of type AGR-21BS/22BS OCR (with S characteristic)

5-3. How to display measurements and make settings

⚠ CAUTION

- OCR setting changes must be performed by competent persons.

The following describes how to display measurements and make settings of the OCR.

5-3-1. General

- 1) Push the right end of the OCR cover to the left at the hollow on the front cover to unlatch and open the OCR cover. See Fig. 45.
If the OCR cover is padlocked, first remove the padlock.

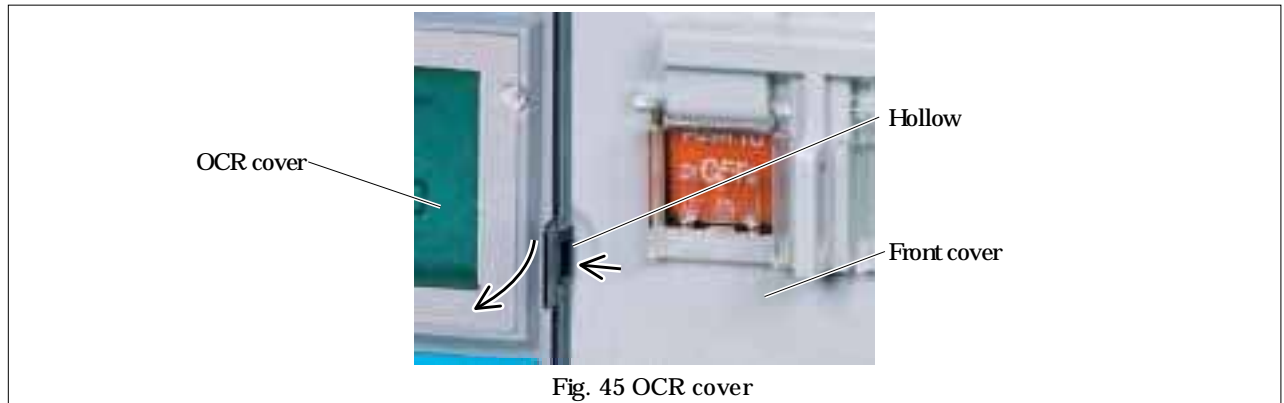

Fig. 45 OCR cover

- 2) Make sure that control power is supplied. Control power supply is required to display measurements.
- 3) The MENU, SET, cross and ENT buttons are used to navigate the LCD screen. Fig. 46 provides the general view of the OCR.

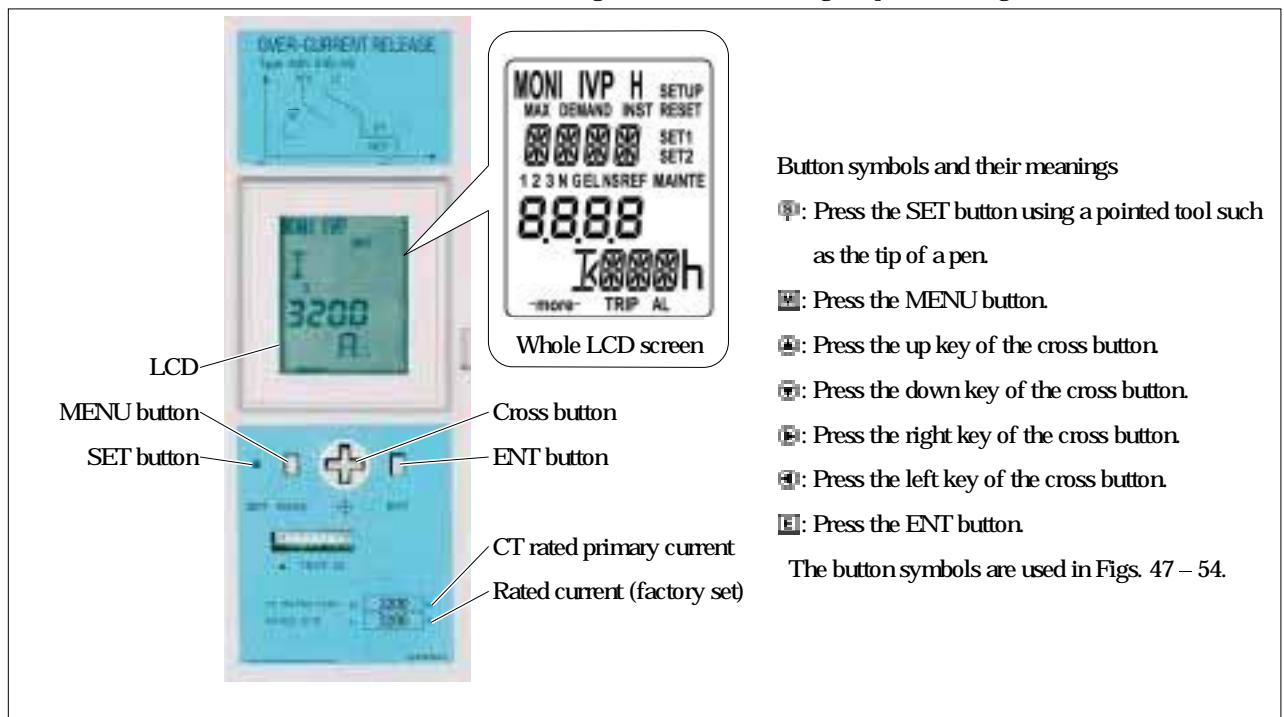
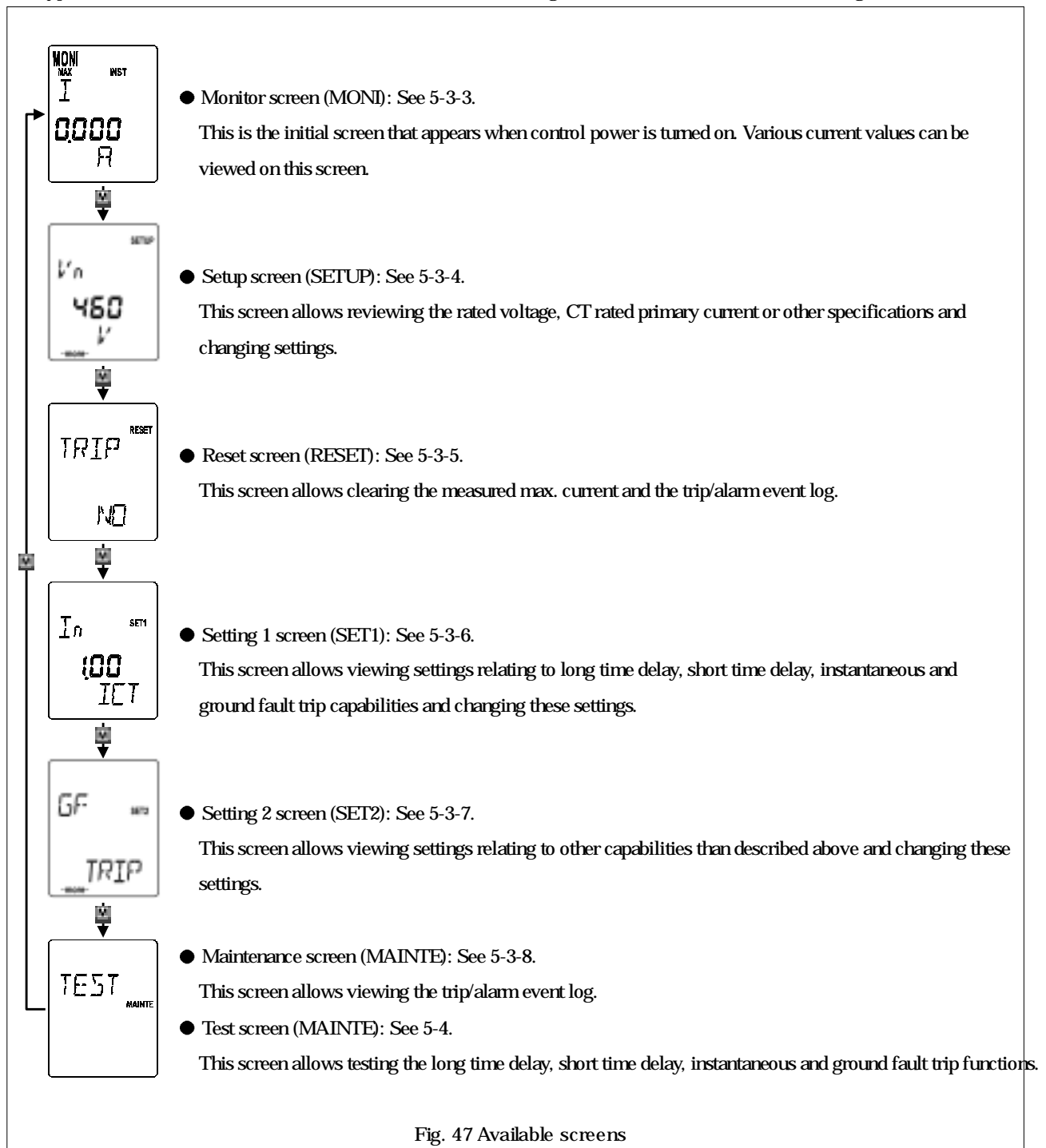

Fig. 46 OCR general view (type AGR-21BL-PG)

- 4) Before changing OCR settings, open the ACB and then lock the OFF button to prevent the ACB from being closed inadvertently. Unlock the OFF button after changing OCR settings.
- 5) Close the OCR cover after viewing measurements or changing settings.
- 6) After setting changes are made, it is recommended that the settings be checked with e.g., a type ANU-1 OCR checker (optional).

5-3-2. Available screens

The type AGR-21B/22B OCR has six screens available as shown in Fig. 21 below. Press the MENU button to go to the next screen.



5-3-3. Monitor screen

Fig. 48 shows how to navigate the monitor screen and Table 23 lists the items that can be viewed on this screen.

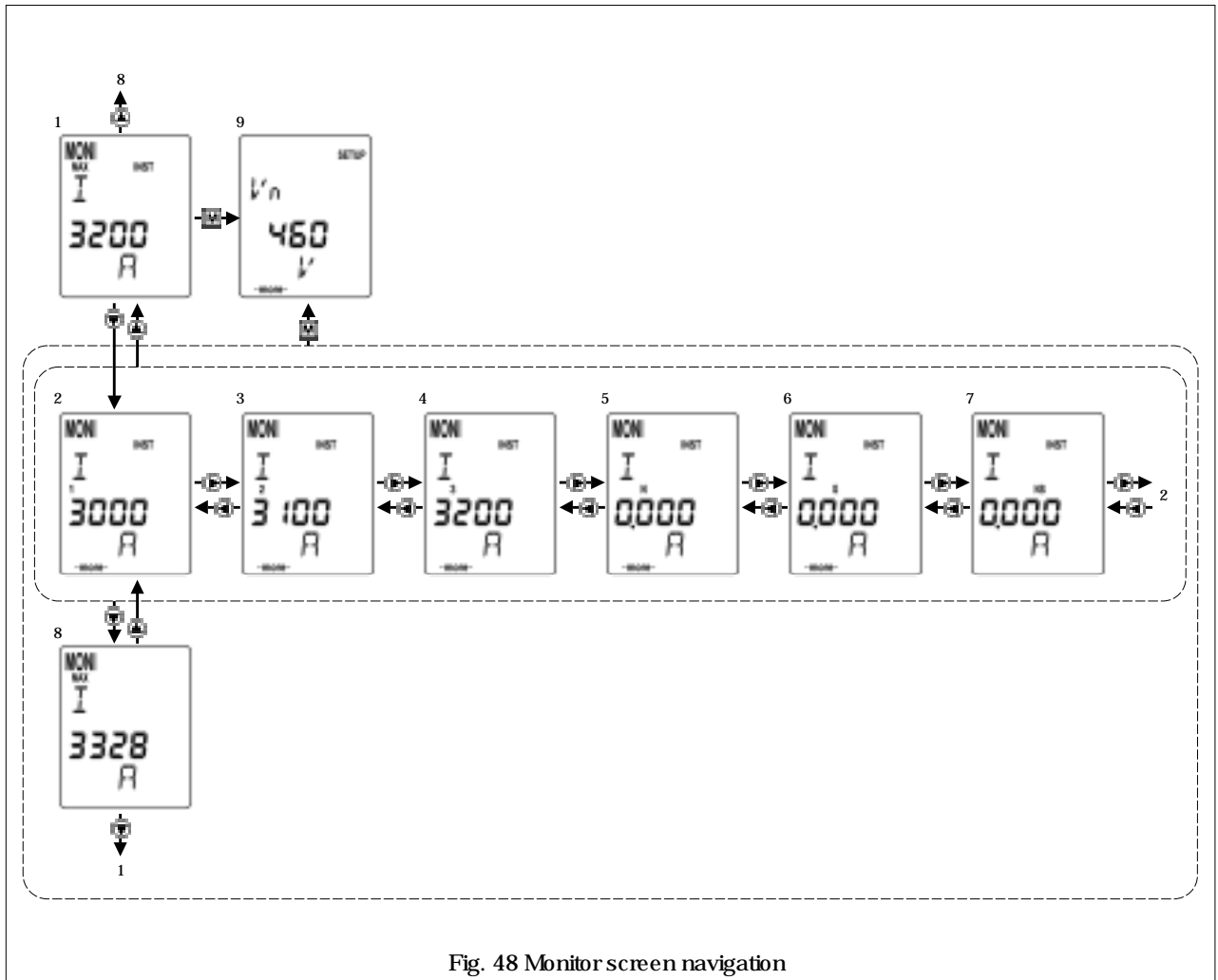

Fig. 48 Monitor screen navigation

Table 23 Monitor subscreens

No.	Subscreen item *1	Description	Tolerance
1	Max. phase current (present value)	Initial display	
2	First phase (R/A-phase) current (present value)	-	For type AGR-21B OCR: ±2.5% of CT rated primary current [I _{CT}]
3	Second phase (S/B-phase) current (present value)	-	Reading will be "0" when < 2.5% of CT rated primary current [I _{CT}].
4	Third phase (T/C-phase) current (present value)	-	
5	Neutral (N-phase) current (present value)	Displayed when THE ACB is of 4-pole type	
6	Ground fault current (present value)	Displayed only when THE ACB is equipped with the ground fault trip function	For type AGR-22B OCR: ±1.5% of CT rated primary current [I _{CT}]
7	Negative-phase current (present value)	Displayed only when THE ACB is equipped with the negative-phase sequence protective function	Reading will be "0" when < 1.5% of CT rated primary current [I _{CT}].
8	Max. phase current	-	
9	(Setup screen)	See 5-3-4.	-

*1 If no value is found for an item, the corresponding subscreen is skipped.

5-3-4. Setup screen

Fig. 49 shows how to navigate the setup screen and Table 24 lists the items that can be viewed on this screen.

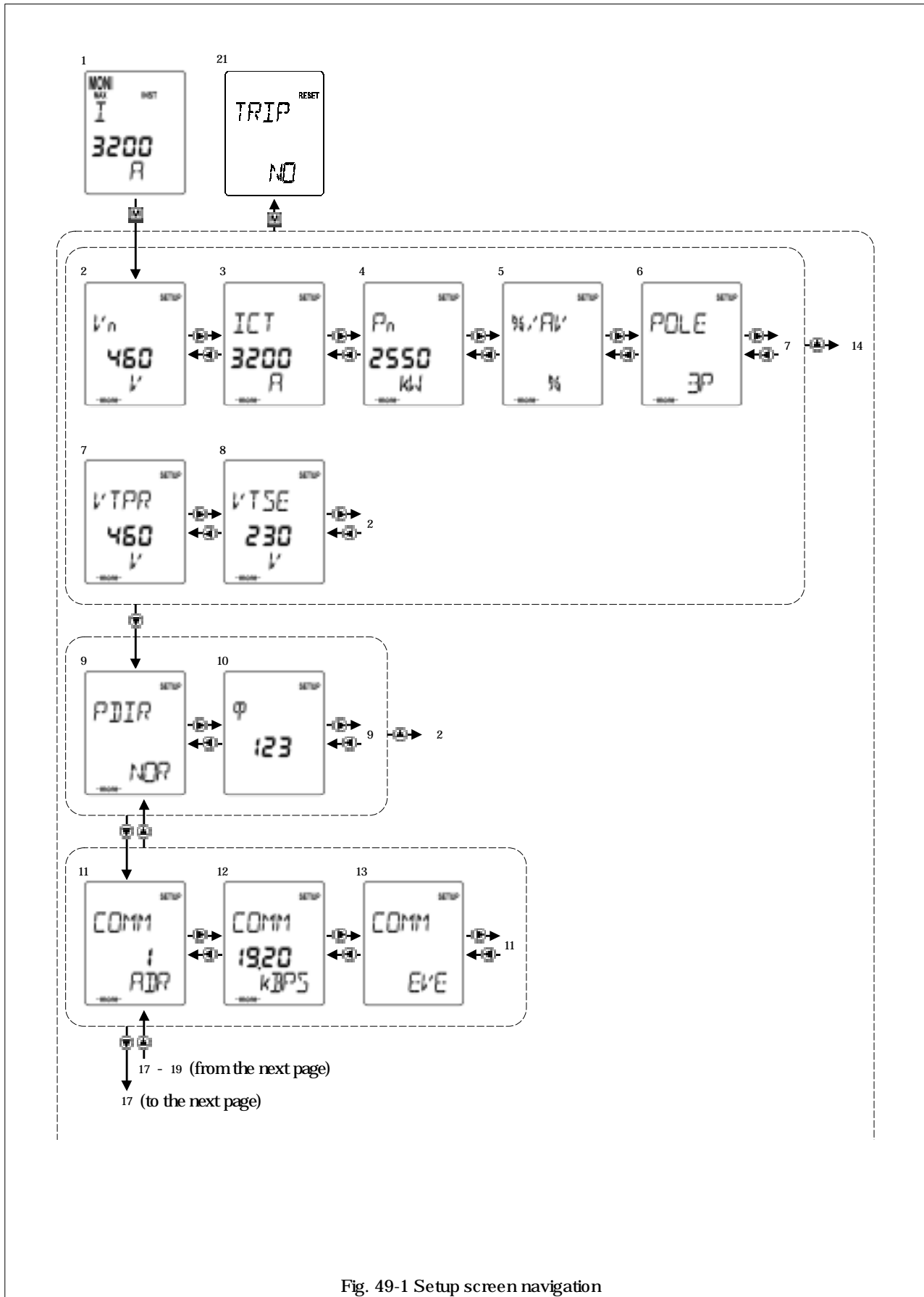

Fig. 49-1 Setup screen navigation

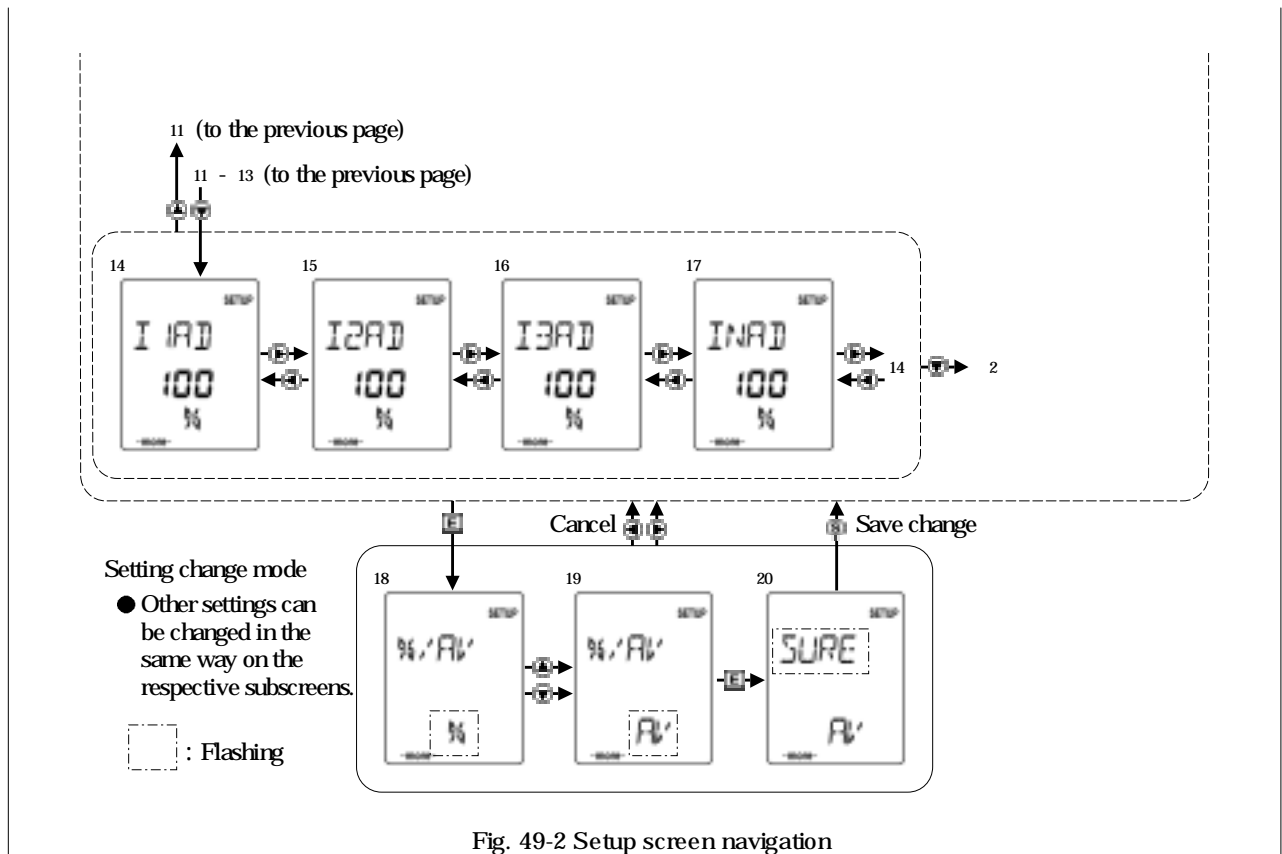

Fig. 49-2 Setup screen navigation

Table 24 Setup subscreens

No.	Subscreen item *1	Setting change	Setting range/Remarks *2
1	(Monitor screen)	-	See 5-3-3.
2	Main circuit rated voltage	Disabled	Fixed *3
3	CT rated primary current	Disabled	Fixed *3
4	Main circuit rated power	Disabled	Determined (calculated with main circuit rated voltage and rated current [I _n])
5	Trip/alarm pickup settings	Enabled	% - AV (%: Percentage of setting reference, AV: Actual current (A)/voltage (V)/power (kW) value)
6	Number of poles	Disabled	Fixed *3
7	PT (potential transformer) primary current	Disabled	Fixed (displayed only when THE ACB is equipped with the reverse power trip function and the main circuit voltage exceeds 250V) *3
8	PT (potential transformer) secondary current	Disabled	Fixed (displayed only when THE ACB is equipped with the reverse power trip function and the main circuit voltage exceeds 250V) *3
9	Polarity	Enabled	NOR-REV (NOR: Normal connection, REV: Reverse connection) Select NOR when the power supply of the load is upstream of the breaker and REV when it is downstream of the breaker.
10	Phase sequence	Enabled	123-321 (123 means RST (ABC) and 321 does TSR (CBA) from left to right, as seen from the front of the ACB)
11	Transmission address	Enabled	01-02...-31 (31 addresses) *4 *5
12	Transmission rate	Enabled	4800/9600/19200 baud
13	Parity	Enabled	<u>EVE</u> -ODD-NON
14	Current adjustment, 1st phase	Enabled	97-98-99-100-101-102-103(%) *6 *7
15	Current adjustment, 2nd phase	Enabled	97-98-99-100-101-102-103(%) *6 *7
16	Current adjustment, 3rd phase	Enabled	97-98-99-100-101-102-103(%) *6 *7
17	Current adjustment, Nth phase	Enabled	97-98-99-100-101-102-103 (%) (Equipped on 4-pole ACBs having the N-phase protection function and/or ground fault trip function) *6 *7
18	Setting change mode "Start"	-	Press ENTER to enter this subscreen from a setup subscreen. The value that can be changed will flash. To exit this subscreen, press the right or left key of the cross button.
19	Setting change mode "Setting change"	-	Press the up or down key of the cross button to change the setting. To exit this subscreen with no change in setting, press the right or left key of the cross button.
20	Setting change mode "Save change"	-	Press ENTER to enter this subscreen from subscreen 19. "SURE" will be flashing. To save the change, press SET. The subscreen will exit to the Reset screen. To exit this subscreen while no change is saved, press the right or left key of the cross button.
21	(Reset screen)	-	See 5-3-5.

*1 If no value is found for an item, the corresponding subscreen is skipped.

*2 Underlined values are default settings.

*3 Factory set according to your request.

*4 The setting procedure is somewhat different from 18 - 20. Press ENT while subscreen 11 is displayed. The ten's digit of the communication address will flash. Use the up or down key of the cross button to change the digit. After changing the ten's digit, press ENT again. The unit's digit of the communication address will flash. Use the up or down key of the cross button to change the digit. After changing the unit's digit, press ENT. "SURE" will start flashing. See the description of subscreen 20.

*5 Communication addresses other than 01 to 31 cannot be specified. Attempting to do so will result in subscreen 11.

*6 Factory set before delivery.

*7 These subscreens are for making corrections to avoid variation in measurement. Settings on the subscreens have no influence upon trip/alarm pickup current values.

5-3-5. Reset screen

Fig. 50 shows how to navigate the reset screen and Table 25 lists the items that can be cleared on this screen. When an item is cleared while its contact output is on, the contact output turns off.

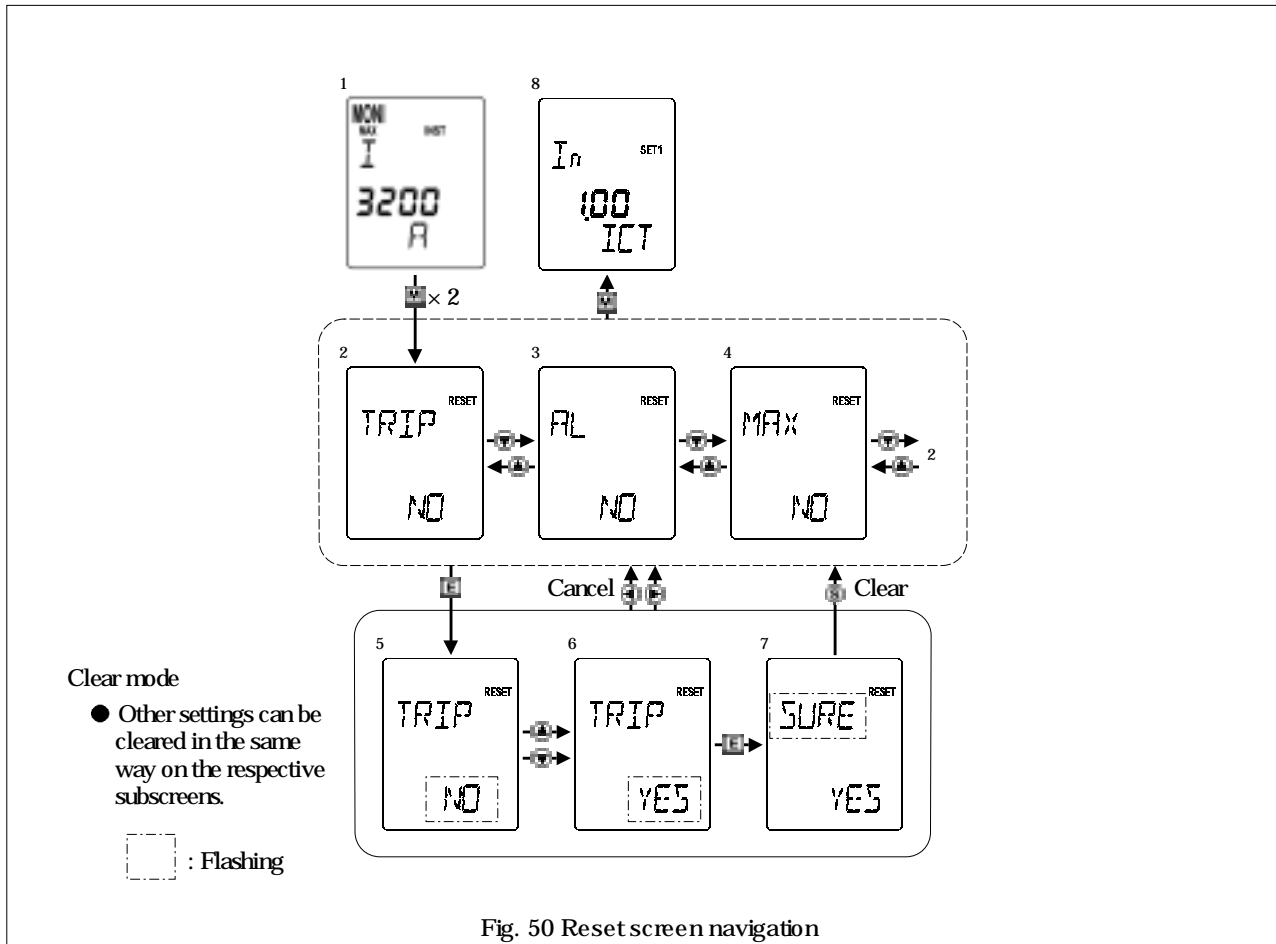

Fig. 50 Reset screen navigation

Table 25 Reset subscreens

No.	Subscreen item	Description
1	(Monitor screen)	See 5-3-3.
2	Trip event log	Allows clearing the trip event log (trip cause, fault current value and operating time).
3	Alarm event log	Allows clearing the alarm event log (alarm cause, fault current value and operating time).
4	Max. phase current	Allows clearing the max. phase current (see Fig. 48 8).
5	Clear mode "Start"	Press ENTER to enter this subscreen from a reset subscreen. "NO" will flash. To exit this subscreen, press the right or left key of the cross button.
6	Clear mode "YES"	Press the up or down key of the cross button. "YES" will appear. To exit this subscreen without clearing the item, press the right or left key of the cross button.
7	Clear mode "Clear"	This subscreen appears when ENTER is pressed while "YES" is appearing. "SURE" will flash. To clear the item, press SET. The subscreen will exit to the Setting 1 screen. To exit this subscreen without clearing the item, press the right or left key of the cross button.
8	(Setting 1 screen)	See 5-3-6.

Table 26 Setting 1 subscreens

No.	Subscreen item *1	Setting range/Remarks *2 *3
1	(Monitor screen)	See 5-3-3.
2	Rated current (L/R characteristic)	$[I_{cr}] \times (0.5-0.63-0.8-1.0)$ (A)
2'	Rated current (S characteristic)	$[I_{cr}] \times (0.5 \text{ to } 1.0)$ (A): Fixed to a single point in increments of 1A
3	Long time delay trip characteristic	SI- <u>VII</u> -EII-3II-4II (SI: $I^{0.02} t$, VII: $I t$, EII: $I^2 t$, 3II: $I^3 t$, 4II: $I^4 t$) *4
4	Long time delay trip pickup current	L/R characteristic: $[I_n] \times (0.8-0.85-0.9-0.95-1.0-NON)$ (A) S characteristic: $[I_n] \times (0.8-1.05-1.1-1.15-NON)$ (A)
5	Long time delay trip pickup time	L characteristic: 0.5-1.25-2.5-5-10-15-20-25-30 (sec) R characteristic: 1-2-3-4-5-6.3-6.8-10 (sec) S characteristic: 15-20-25-30-40-50-60 (sec)
6	Long time delay trip mode HOT/COLD	COLD/HOT
7	N-phase protection trip pickup current	$[I_{cr}] \times (0.4-0.5-0.63-0.8-1.0)$ (A)
8	Short time delay trip pickup current	L/R characteristic: $[I_n] \times (1-1.5-2-2.5-3-4-6-8-10-NON)$ (A) S characteristic: $[I_n] \times (2-2.5-2.7-3-3.5-4-4.5-5-NON)$ (A)
9	Short time delay trip pickup time	L/R characteristic: 0.05-0.1-0.2-0.4-0.6-0.8 (sec) S characteristic: 0.1-0.2-0.3-0.4-0.6-0.8 (sec)
10	Short time delay trip I ² t protection type	OFF/ON
11	Instantaneous trip pickup current	$[I_n] \times (2-4-6-8-10-12-14-16-NON)$ (A)
12	Instantaneous trip INST/MCR	INST/MCR
13	Setting change mode "Start"	Press ENTER to enter this subscreen from a setting 1 subscreen. The value that can be changed will flash. To exit this subscreen, press the right or left key of the cross button.
14	Setting change mode "Setting change"	Press the up or down key of the cross button to change the setting. To exit this subscreen with no change in setting, press the right or left key of the cross button.
15	Setting change mode "Save change"	Press ENTER to enter this subscreen while subscreen 14 is displayed. "SURE" will flash. To save the change, press SET. The subscreen will exit to the Setting 2 screen. To exit this subscreen while no change is saved, press the right or left key of the cross button.
16	(Setting 2 screen)	See 5-3-7.

*1 If no value is found for an item, the corresponding subscreen is skipped.

*2 Underlined values are default settings.

*3 This table shows percent representations of settings. For AV representations (see 5-3-4), current values are indicated in A (Amperage).

*4 Factory set according to your request.

5-3-7. Setting 2 screen

Fig. 52 shows how to navigate the Setting 2 screen and Table 27 lists the items that can be viewed or changed on this screen.

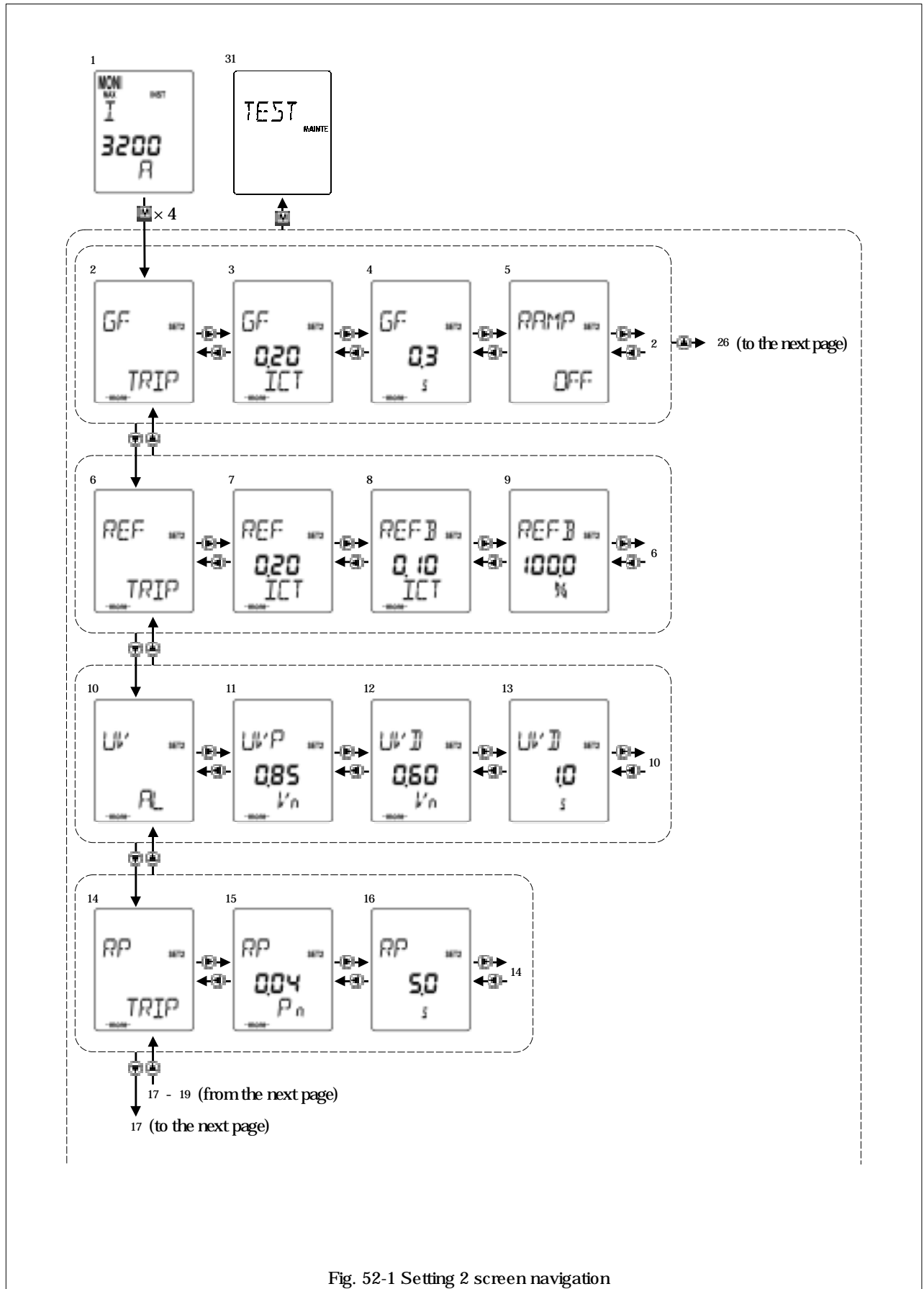

Fig. 52-1 Setting 2 screen navigation

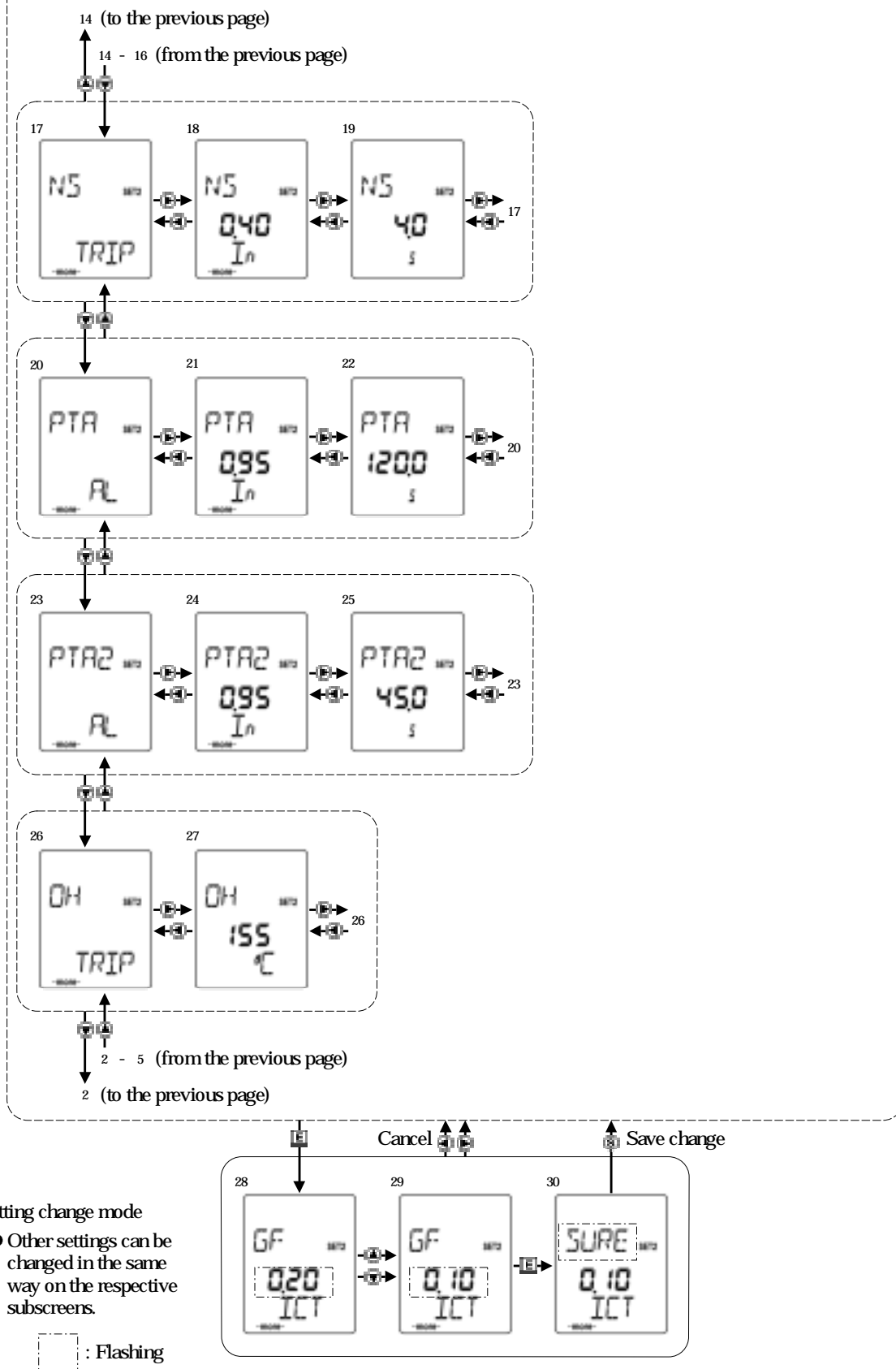

Fig. 52-2 Setting 2 screen navigation

Table 27 Setting 2 subscreens

No.	Subscreen item *1	Setting range/Remarks *2 *3
1	(Monitor screen)	See 5-3-3.
2	Ground fault trip mode	TRIP/AL/OFF
3	Ground fault trip pickup current	$[I_{CT}] \times (0.1-0.2-0.3-0.4-0.6-0.8-1.0-NON)$ (A)
4	Ground fault trip pickup time	0.1-0.2- <u>0.3</u> -0.5-1-2 (sec)
5	Ground fault trip Ft protection type	OFF/ON
6	Line side ground fault protection mode	TRIP/AL/OFF
7	Line side ground fault protection trip pickup current	$[I_{CT}] \times (0.1-0.2-0.3-0.4-0.6-0.8-1.0-NON)$ (A)
8	Line side ground fault protection bias current	$[I_{CT}] \times (0.1-0.3-0.5-0.7-0.9-1.1-1.3-1.5)$ (A) *4
9	Line side ground fault protection bias limit	100% (fixed) *4
10	undervoltage alam mode	AL/OFF
11	Undervoltage alam recovery voltage	$[V_n] \times (0.8-0.85-0.9-0.95)$ (V)
12	Undervoltage alam pickup voltage	$[V_n] \times (0.4-0.6-0.8)$ (V)
13	Undervoltage alam pickup time	0.1-0.5- <u>1</u> -2-5-10-15-20-30-36 (sec)
14	Reverse power trip mode	TRIP/AL/OFF
15	Reverse power trip pickup power	$[P_n] \times (0.04-0.05-0.06-0.07-0.08-0.09-0.1-NON)$ (kW)
16	Reverse power trip pickup time	2.5-5-7.5-10-12.5-15-17.5-20 (sec)
17	Negative-phase sequence protection mode	TRIP/AL/OFF
18	Negative-phase sequence protection trip pickup current	$[I_n] \times (0.2-0.3-0.4-0.5-0.6-0.7-0.8-0.9-1.0)$ (A)
19	Negative-phase sequence protection trip pickup time	0.4-0.8-1.2-1.6-2-2.4-2.8-3.2-3.6- <u>4</u> (sec)
20	Pretrip alam mode	AL/OFF
21	Pretrip alam pickup current	L/R characteristic: $[I_n] \times (0.75-0.8-0.85-0.9-0.95-1.0)$ (A) S characteristic: $[I_n] \times (0.75-0.8-0.85-0.9-0.95-1.0-1.05)$ (A)
22	Pretrip alam pickup time	L/R characteristic: 5-10-15-20-40-60-80- <u>120</u> -160-200 (sec) S characteristic: 10-15-20-25- <u>30</u> (sec)
23	Pretrip alam 2 mode	AL/OFF
24	Pretrip alam 2 pickup current	$[I_n] \times (0.75-0.8-0.85-0.9-0.95-1.0-1.05)$ (A)
25	Pretrip alam 2 pickup time	$1.5 \times t_1$ (sec) (determined by auto calculation)
26	Contact overheat monitor mode	TRIP/AL/OFF
27	Contact overheat alam pickup temperature	155°C (fixed)
28	Setting change mode "Start"	Press ENTER to enter this subscreen from a setting 2 subscreen. The value that can be changed will flash. To exit this subscreen, press the right or left key of the cross button.
29	Setting change mode "Setting change"	Press the up or down key of the cross button to change the setting. To exit this subscreen with no change in setting, press the right or left key of the cross button.
30	Setting change mode "Save change"	Press ENTER to enter this subscreen from subscreen 29. "SURE" will flash. To save the change, press SET. The subscreen will exit to the Setting 2 screen. To exit this subscreen while no change is saved, press the right or left key of the cross button.
31	(Maintenance screen)	See 5-3-8 and 5-4.

*1 If no value is found for an item, the corresponding subscreen is skipped.

*2 Underlined values are default settings.

*3 This table shows percent representations of settings. For AV representations (see 5-3-4), current values are indicated in A (Amperage), V (voltage), or kW (kilowatt).

*4 The line side ground fault protection bias current and bias limit are coefficients for strain. Because the line side ground fault protection function performs an arithmetic operation using the difference between CTs with different characteristics, errors in measured line side ground fault current become significant when a large current flows through the ACB. "Strain" is to increase the line side ground fault trip pickup current with increasing current flowing through the ACB, thus preventing malfunctions caused by such an error. The following shows the relationship between the current flowing through the ACB and the line side ground fault protection trip pickup current under "strained" conditions:

When $(i + i_{REFCT}) / 2 \leq I_{REF2}$;

$I_{REFNOW} = I_{REF}$

When $(i + i_{REFCT}) / 2 > I_{REF2}$;

$I_{REFNOW} = I_{REF} [1 + a \{ (i + i_{REFCT}) / 2 I_{REF2} - 1 \}]$

(I_{REF} : Line side ground fault protection trip pickup current, I_{REF2} : Line side ground fault protection bias current, a: Line side ground fault protection bias limit, i: Max. phase current (present value), i_{REFCT} : Line side ground fault current, I_{REFNOW} : Line side ground fault protection pickup current calculated using strain coefficients)

Ex.: When $(i + i_{REF}) / 2 = 5 \times I_{REF2}$ and other settings remain default;

$I_{REFNOW} = I_{REF} [1 + 1 \times \{ 5 \times I_{REF2} / I_{REF2} - 1 \}] = I_{REF} [1 + 1 \times \{ 5 - 1 \}] = 5 \times I_{REF}$

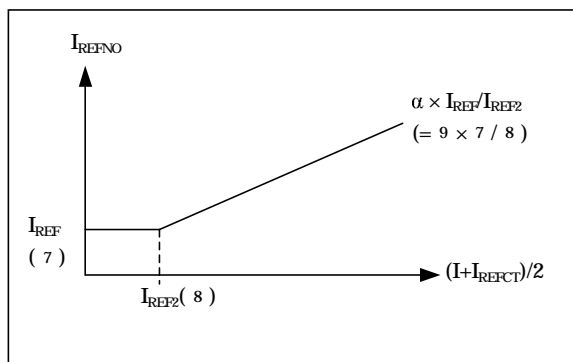

Fig. 53 Relationship between the current flowing through the ACB and the line side ground fault protection trip pickup current under "strained" conditions

5-3-8. Maintenance screen

Fig. 53 shows how to navigate the maintenance screen and Table 28 lists the items that can be viewed on this screen.

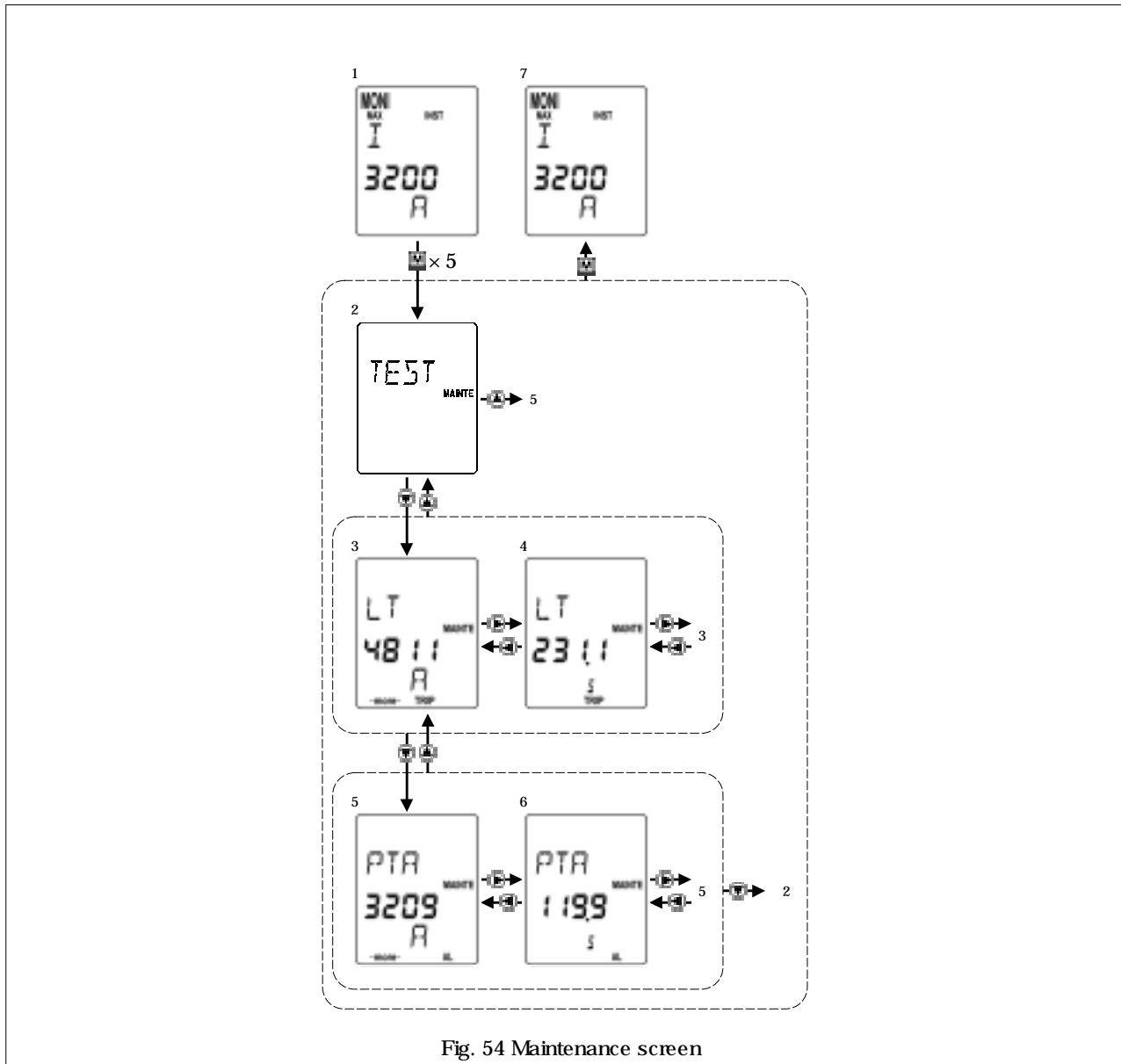

Fig. 54 Maintenance screen

Table 28 Maintenance subscreens

No.	Subscreen item *1	Description
1	(Monitor screen)	See 5-3-3.
2	(Maintenance screen)	-
3	Trip event log (fault current value)	Trip cause and fault current value
4	Trip event log (operating time)	Trip cause and operating time
5	Alarm event log (fault current value)	Alarm cause and fault current value
6	Alarm event log (operating time)	Alarm cause and operating time
7	(Monitor screen)	See 5-3-3.

*1 If no value is found for an item, the corresponding subscreen is skipped.

5-4. OCR Function Check

⚠ CAUTION

- OCR function check and setting changes must be performed by competent persons.
- After completion of OCR tests, be sure to return the settings to the original values. Failure to do so may cause a fire or burnout.

Use the following procedure to perform OCR function check.

- 1) Open the ACB and draw out the breaker body to the TEST position.
- 2) Change settings according to the test as shown in Table 29.

Table 29 OCR setting changes

Test *1	Output signal value	Setting to be changed
Long time delay trip	L characteristic: $[I_R] \times 6$	Non
	R characteristic: $[I_R] \times 3$	Non
	S characteristic: $[I_R] \times 1.2$	Non
Short time delay trip	$[I_{sd}] \times 1.2$	$[I] > [I_{sa}] \times 1.5$, Short time delay trip Ft protection: OFF
Instantaneous trip	$[I_i] \times 1.2$	Mode: INST
MCR		Mode: MCR
Ground fault trip	$[I_g] \times 1.5$	Ground fault trip Ft protection: OFF

*1 Setting an item to NON disables the test for the item.

- 3) To check the ACB along with the OCR, close the ACB before applying a test signal. When checking the MCR function, close the ACB within 0.3 sec. after applying a test signal.
- 4) Follow the procedure described in Fig. 54 and Table 30 to check the OCR for normal operation. (In NTR mode, the ACB does not operate, a trip/alarm event is not saved in the log and operation indication contact output is not provided).

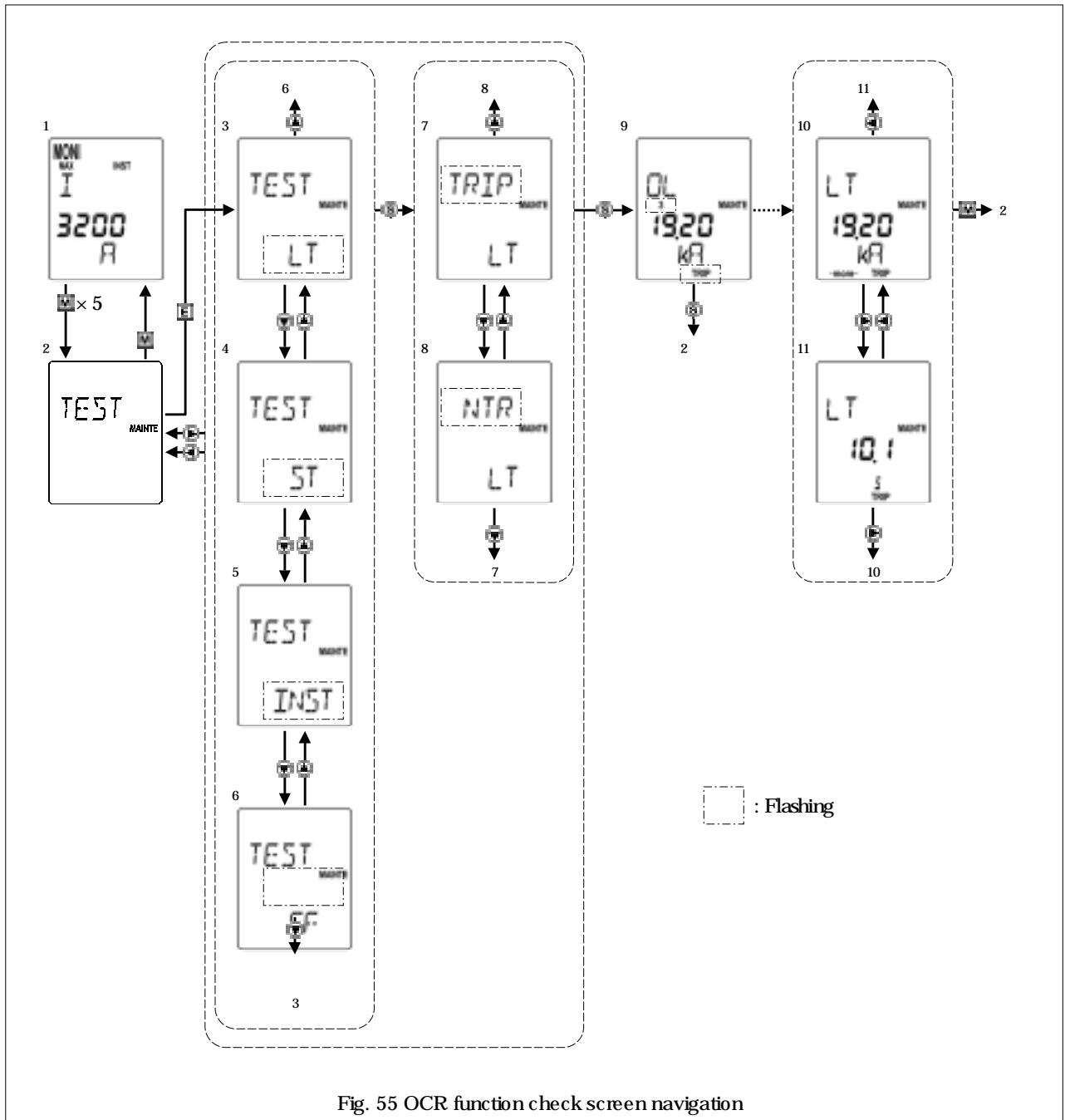

Fig. 55 OCR function check screen navigation

Table 30 OCR function check subscreens

No.	Subscreen item *1	Description
1	(Monitor screen)	See 5-3-3.
2	(Function check start subscreen)	-
3	Long time delay trip	"LT" flashes. *2 *3
4	Short time delay trip	"ST" flashes.
5	Instantaneous trip	"INST" flashes.
6	Ground fault trip	"GF" flashes.
7	OCR + ACB operation	"TRIP" flashes.
8	OCR operation only	"NTR" flashes.
9	Indication during testing *4	Pressing SET while subscreen 7 or 8 opens causes a test signal to be applied.
10	Trip event log (fault current value)	The trip cause and fault current value are indicated.
11	Trip event log (operating time)	The trip cause and operating time are indicated.

*1 If no log is found, the corresponding subscreen is skipped.

*2 When the long time delay trip function is selected, the short time delay trip and instantaneous trip functions are locked inoperative and cannot be used. The pretrip alarm function can be used.

*3 Even when the HOT mode is selected, the test is carried out in COLD mode (Accumulated current value before testing is reset to zero before the test starts).

*4 Only when the long time delay trip function is checked. The number of the signal source and "TRIP" are flashing. For other function checks, subscreen 7 or 8 will continue.

5-5. Operation Indication and Indication Resetting Procedure

The OCR indicates a trip/alarm event on the LCD and provides contact output as shown in Table 31. Pressing the right or left key of the cross button changes the display from "trip/alarm cause" / "fault current/voltage/power" to "operating time" (if applicable).

Pressing the MENU button returns the display to the previous screen. (Events saved in the event log can always be displayed on the maintenance screen. See 5.3.8). To reset contact output while retaining the event log, turn off the control power (Fig. 15 01, 11, 21) at least 1 sec. To delete the event log and reset contact output on the LCD, follow the procedure shown in 5.3.5 "Reset screen".

Table 31-1 Operation indication 1

Operation	LCD State				Terminal No. See Fig. 15	Contact output State			Control power supply	
	Normal operation	When picked up	When activated (Use the right or left key of the cross button for screen navigation)			After control power is off for at least 1 sec.	Normal operation	When activated		After control power is off for at least 1 sec.
Long time delay trip (LT) N-phase protection (NP)	Normal indication				Normal indication 1	OFF	ON 2	OFF	Required	
Short time delay trip (ST)		-					ON 2			
Instantaneous trip (INST/MCR)		-					ON 2			
Ground fault trip (GF)		-					ON			
Reverse power trip (RPT)							ON 2			
Negative-phase sequence protection (NS)							ON			
Line side ground fault protection (REF)		-					ON			

● The ACB can be opened, closed or tripped, irrespective of whether or not the operation indication is reset.

● The operation indication is updated when a protective function is activated.

● means flashing.

1 The event log is not cleared.

2 For S characteristic, the delay is as short as 500 ms or more.

3 "---- (kA)" is indicated when the short time delay or instantaneous trip function is activated and $[I_{cr}] \times 17$ is exceeded.

Table 31-2 Operation indication 2

Operation	LCD State				Terminal No. See Fig. 10	Contact output State			Control power supply	
	Normal operation	When picked up	When activated			After control power is off for at least 1 sec.	Normal operation	When activated		After control power is off for at least 1 sec.
Contact overheat monitoring (OH)		-			Normal indication 1	05 - 17	ON	OFF	Required	
Pretrip alarm (PTA)					Normal indication 1 2	05 - 06	ON 2	OFF		
Pretrip alarm 2 (PTA2)	Normal indication				Normal indication 1 2	05 - 27	OFF	ON 2		OFF
Undervoltage alarm (UV)		-			Normal indication 1 2	05 - 27	ON 2	OFF		
System alarm		-			Normal indication 1	05 - 26	ON 3	OFF 4		

- The ACB can be opened, closed or tripped, irrespective of whether or not the operation indication is reset.
- The operation indication is updated when a protective function is activated.
- means flashing
- 1 The event log is not cleared.
- 2 The alarm is self-recovered when the fault current decreases to less than the setting.
- 3 "SYS1" means disconnection of the magnet hold trigger (MHT) and "SYS2" does a tripping failure (incorrect operating time, mechanical malfunction etc).
- 4 The OCR has a self-monitoring feature that monitors the OCR internal circuit, the magnet hold tripper (MHT) circuit, and the ACB state. An alarm caused by transient noise can be cleared or deleted. If such an alarm cannot be cleared, check the ACB. See chapter 7.

6. MAINTENANCE, INSPECTION AND PARTS REPLACEMENT

This chapter describes the maintenance and inspection procedure for the AR series ACBs.

The service life of the ACB depends on the working and environmental conditions. The ACB is exposed to mechanical and electrical stresses and thus suffers gradual degradation during use, which will increase the possibility of malfunctions. Preventive maintenance and periodical inspection are very important to avoid any functional degradation, prevent malfunctions, extend the service life, and ensure safe operation.

The appropriate frequency of maintenance and inspection of the ACB varies depending on the installation conditions, the number of tripping operations, the magnitude of breaking current, and other factors that are to be considered empirically. As a guideline, Table 32 shows the recommended inspection frequency. See section 6-1 for detailed maintenance and inspection procedures.

Table 32 Frequency of maintenance and inspection

Category	Working and environmental conditions	Inspection level	Frequency in interval or number of open/close cycles				
			Interval	Number of open/close cycles			
Normal	<ul style="list-style-type: none"> Not so dusty, Not so much corrosive gases, Ambient temperature: 35°C or lower Not so humid, Number of open/close cycles per day: 2 or less Ex. Switchboards in electric installation rooms, Control rooms, Building installation 	Normal/ Detailed	<ul style="list-style-type: none"> Every year or 2 years Every year after 3 years since installation Every half year after 6 years since installation 	Open/close condition	800AF or less	1250AF - 2500AF	3200AF or more
				Nearly no current level	Every 1000 cycles		
		Rated current level	Every 1000 cycles	Every 500 cycles	Every 100 cycles		
		Thorough	<ul style="list-style-type: none"> Every 5 or 6 years Every 4 years after 6 years since installation Every year or 2 years after 10 years since installation 	Every 4000 cycles			
		Overhaul	When abnormality is found during normal or through inspection				
Harsh	<ul style="list-style-type: none"> Highly dusty, Much corrosive gases, Ambient temperature: 45°C or higher, Highly humid, Number of open/close cycles per day: 4 or more, Always exposed to vibrations Ex. Iron or chemical plants Engine rooms (without ventilation), Cogeneration installation, Ferryboats 	Normal/ Detailed	<ul style="list-style-type: none"> Every year Every half year after 2 years since installation 	Open/close condition	800AF or less	1250AF - 2500AF	3200AF or more
				Nearly no current level	<ul style="list-style-type: none"> Every 1000 cycles Every 500 cycles after 1000 cycles 		
		Rated current level	<ul style="list-style-type: none"> Every 1000 cycles Every 500 cycles after 1000 cycles 	<ul style="list-style-type: none"> Every 500 cycles Every 250 cycles after 500 cycles 	<ul style="list-style-type: none"> Every 100 cycles Every 50 cycles after 100 cycles 		
		Thorough	<ul style="list-style-type: none"> Every 2 or 3 years Every 2 years after 6 years since installation Every year after 10 years since installation 	<ul style="list-style-type: none"> Every 2500 - 3000 cycles Every 2000 cycles after 3000 cycles 			
		Overhaul	When abnormality is found during normal or through inspection				
Abnormal	<ul style="list-style-type: none"> Open/close operation due to overload, Tripping due to shortcircuit, Accidentally submerged 	Thorough	When abnormality occurs	Open/close condition	800AF or less	1250AF - 2500AF	3200AF or more
				Overcurrent level (approx. 6 times the rated current)	Every 25 cycles	Every 25 cycles	Every 25 cycles
		Level exceeding overcurrent level	Every time	Every time	Every time		
		Overhaul	When ACB is deemed to be repairable at through inspection				

- Normal inspection includes inspection and actions that can be done only with removing the arc chamber, contacts, front cover and the like. Normal inspection can be performed by the user. Terasaki also provides normal inspection service.
- Detailed inspection includes inspection, actions, and parts replacement that will be done to prevent functional degradation caused by aging or the like when abnormality is found during normal inspection. You are recommended to use Terasaki's detailed inspection service.
- Thorough inspection must be left to Terasaki. Overhaul will be done in a Terasaki's factory.

● About the service life

The expected service life of AR series ACBs is shown in the "Endurance in number of ON-OFF cycles" rows in Tables 3 and 4. "With maintenance" in the tables means that appropriate inspection, maintenance, repair, and parts replacement are performed according to the instructions in this chapter. But, when an ACB performs three times of tripping operation nearly at the rated breaking current (three standard operating duty cycles), it is at the end of its safe service life even if thorough inspection is done every time it trips open. Such an ACB will be apt to suffer malfunctions and should be replaced without delay to avoid frequent inspection and parts replacement. See section 6-2 for detailed parts replacement procedures.

6-1. Inspection Procedures

⚠ CAUTION

- ACB maintenance, inspection and parts replacement must be performed by competent persons.
- Do not touch ACB current carrying parts and ACB structural parts close to a current carrying part immediately after the ACB trips open. Remaining heat may cause a burn.
- Prior to commencing any work on the ACB, open an upstream circuit breaker or the like to isolate all sources of power/voltage from the main and control circuits. Otherwise, electric shock may result.
- Take care to avoid adhesion of dust to main and control circuit contacts. Dust on the contacts may result in a fire.
- Prior to commencing maintenance, inspection, or parts replacement, make sure that the closing springs are released and the ACB is open. Otherwise, unintentional open/close operation may lead to fingers or tools to be pinched by the open/close mechanism, resulting in injury.
- Retighten the terminal screws periodically to the specified torque. Otherwise, a fire could result.
- When grinding a contact tip, be careful to prevent grinding dust from entering the breaker operating mechanism. Wipe the tip clean after grinding. Otherwise, a malfunction or fire could result.
- Do not perform dielectric withstand/insulation resistance tests under other conditions than specified. Doing so may cause a malfunction.
- Be sure to reinstall the arc chamber if removed. Failure to do so or incorrect installation of the arc chamber may result in a fire or burn.
- When charging the closing springs or performing open/close operation of the ACB with the arc chamber, front cover and/or side covers removed during maintenance or inspection work, do not touch parts other than those required for the above operation (charging handle, ON/OFF buttons, moving core and the like). Doing so may cause fingers or tools to be pinched, resulting in injury.
- When replacing an auxiliary, do not damage the control wire for the auxiliary or pinch the wire between the auxiliary and the breaker body. Doing so may cause a malfunction.

To ensure safety, be sure to perform the preparation work described in section 6-2-1 unless otherwise specified in the inspection procedures. The normal inspection procedure and the detailed inspection procedure are shown in Tables 34 and 35 respectively.

● Information you are requested to state

If you want us to take action against an abnormality, contact us while providing us the information shown in Table 33 below. Our contact is shown at the end of this manual.

Table 33 Information you are requested to state

Item	Description	Reference
Type	AR_____ poles with draw-out cradle	Rating nameplate
Serial No.	_____ - _____	
Main circuit rated current	<input type="checkbox"/> AC <input type="checkbox"/> DC _____ V	Product Specifications
Rated voltage	_____ A	I_n
Spring charging method	<input type="checkbox"/> Manual charging <input type="checkbox"/> Motor charging Rated operation voltage: <input type="checkbox"/> AC <input type="checkbox"/> DC _____ V	CLOSING section on specification nameplate
Overcurrent release	<input type="checkbox"/> Non <input type="checkbox"/> Equipped Type: AGR-2_____ - _____ Rated control voltage: <input type="checkbox"/> AC <input type="checkbox"/> DC _____ V	OCR section on specification nameplate
Electrical tripping device	<input type="checkbox"/> Shunt trip device (SHT) Rated voltage: <input type="checkbox"/> AC <input type="checkbox"/> DC _____ V <input type="checkbox"/> Undervoltage trip device (UVI) Rated voltage: <input type="checkbox"/> AC <input type="checkbox"/> DC _____ V	TRIPPING section on specification nameplate
Special specification	SR: _____ SS: _____ SO: _____	OTHERS section on specification nameplate
Working conditions (Voltage, current, environment)		-
Symptom of abnormality (in detail): When, How, Where, etc.)		-
Inspection done/actions taken (if any)		6-1.
Status quo and schedule	Permissible power cut date and time: _____ Place where you want us to take action: _____	-

- The contents of the nameplate should be provided in detail.
- Related documents such as product specifications and inspection reports should be provided.
- If you have a desired inspection and maintenance schedule, let us know the schedule at your earliest convenience. Our service representative could not meet your last minute requirement.

Table 34 Normal inspection procedure

Check point	No.	Check item	Description							
General (*1)	1	Discoloration of conductors	Check connection conductors, main circuit terminals, and current carrying parts for heat discoloration. If such a symptom is found, contact us.							
	2	Parts missing	Check that screws, bolts, nuts, washers, springs, retainers and the like are not missing. If any parts are missing, contact us.							
	3	Damage to parts	Check for deformation, cracks, chips, rust, or other damage of parts. If damage is found, contact us.							
	4	Dust accumulation	Check that no dust is accumulated in ACB. If dust is accumulated, use vacuum cleaner to remove dust and wipe off with dry, clean cloth.							
Main/control circuit terminals See 2-3.	5	Connections	Check main circuit terminal screws, ground terminal screw, auxiliary switch terminal screws, control circuit terminal screws, and position switch terminal screws for looseness. If loose, tighten to specified torque.							
Main/control circuit contacts See 4-2.	6	Surface condition	Draw out the breaker body from draw-out cradle and check that contacts have no dust accumulation and discoloration. If dust is accumulated, use vacuum cleaner to remove dust and wipe off with dry, clean cloth. If surface is discolored badly, polish it with #200 sandpaper. (*2) For main circuit contacts, apply contact grease (SS grease, No. F-5G, FUJI KAGAKU SANGYO) to contact surface after cleaning. <ul style="list-style-type: none"> Excessive grease may foster dust accumulation. Grease should be applied lightly. Blackening of contacts is caused by oxidation or sulfuration and has no harmful effect except in extreme cases. If heat discoloration, arc marks, roughness, or peeling of plating layer is found, contact us. 							
Arc chamber See 6-2-2.	7	Dust accumulation /Damage	Remove arc chamber and check it for foreign object or dust accumulation, deformation, cracks, chips and other damage. If foreign matter or dust is accumulated, use vacuum cleaner to remove foreign matter of dust and wipe off with dry, clean cloth. If metal spatters are adhered, use sandpaper to remove them. (*2) If arc chamber has stubborn adherents suffers damage, replace arc chamber.							
Main circuit, Arc chamber See 6-2-2.	8	Insulation resistance	Close ACB and, using DC500V Megger, check that insulation resistance between main circuit terminals, between main circuit terminal group and ground, and between ends of adjacent grids exceeds 5M ohm. If resistance does not exceed 5M ohm, use sandpaper to remove carbonized portions of insulation around contacts or current carrying parts and/or spatters adhered to arc chambers and arc extinguishing grids. (*2) If problem persists, contact us.							
Contacts See 6-2-2, 6-2-3 and 6-2-4.	9	Surface condition	Remove arc chamber and check contact circumference, contacts, and contact tips for foreign object or dust accumulation, deformation, cracks, chips and other damage. If dust is accumulated, use vacuum cleaner to remove dust and wipe off with dry, clean cloth. If contact tips are badly discolored or roughened, polish with #200 sandpaper. (*2) If contact tip suffers damage or is less than 0.7 mm thick after polishing, replace both moving and stationary contacts. <ul style="list-style-type: none"> Blackening of contact tips is caused by oxidation or sulfuration and will be removed during closing operation. It has no harmful effect except in extreme causes. If heat discoloration is found, perform detailed inspection. 							
	10	Looseness of screws	Check moving and stationary contact mounting screws A and B for looseness. Also check the moving arcing contact mounting nut for looseness when ship classification society rules apply. If loose, retighten.							
Control circuit See 6-2-5.	11	Wiring	Remove side and front covers, check that wiring is properly connected, and not disconnected nor damaged. If incorrect connection is found, connect correctly. If disconnection or damage is found, contact us.							
Operating mechanism See 6-2-7.	12	Internal mechanism	With OCR removed, check internal mechanism for missing parts, deformation, cracks, chips, foreign matter or dust accumulation, breakage of springs, and rust. If foreign matter or dust is accumulated, use vacuum cleaner to remove foreign matter of dust and wipe off with dry, clean cloth. If any parts are missing or damaged or springs are broken, contact us.							
Auxiliary switches See 6-2-9.	13	Operation	Check that auxiliary switches operate as shown to the right. If not so, replace switches.							
			<table border="1"> <thead> <tr> <th>State of operation lever</th> <th>Current conducting between _11 and _12</th> <th>Current conducting between _11 and _14</th> </tr> </thead> <tbody> <tr> <td>Natural position</td> <td>100 m or less</td> <td>Non</td> </tr> <tr> <td>Uppermost lift position</td> <td>Non</td> <td>100 m or less</td> </tr> </tbody> </table>	State of operation lever	Current conducting between _11 and _12	Current conducting between _11 and _14	Natural position	100 m or less	Non	Uppermost lift position
	State of operation lever	Current conducting between _11 and _12	Current conducting between _11 and _14							
Natural position	100 m or less	Non								
Uppermost lift position	Non	100 m or less								
14	Auxiliary contacts	Remove auxiliary switches and check contacts for roughness. If roughened excessively, replace contacts.								
	15	Looseness of screws	Check screws of auxiliary switches for looseness. If loose, retighten.							
Operation related mechanism See 4-1 and 4-2.	16	Draw-out/insertion mechanism	Draw out and insert breaker body to check that draw-out handle can be turned with max. operating torque or less, position indicator provides correct indication, release button operates normally, and no abnormal sound is heard during handle operation. If abnormality is found, contact us.							
	17	UVT	With breaker body in ISOLATED position, charge closing springs manually and attempt closing ACB to make sure ACB cannot be closed. If ACB can be closed, perform detailed inspection.							
	18	Operation mechanism, IRC, SHT and UVT	With breaker body in TEST position and operation mechanism, SHT and UVT supplied with power, perform closing spring charging operation and manual and electrical open/close operation several times to check that charge indicator, ON-OFF indicator and ON-OFF cycle counter provide correct indication and no abnormal sound is heard. If abnormality is found, perform detailed inspection.							
OCR and MHT	19	System alarm	Move the breaker body to the TEST position and supply the ACB with control power, and then check that no system alarm appears on the OCR. If a system alarm appears, reset it. If the alarm cannot be reset, see chapter 7.							

*1 Always check the "General" items during the inspection procedure shown in Table 34 above.

*2 Take care to avoid grinding dust from entering the ACB. Wipe contact surfaces clean of grinding dust.

Table 35 Detailed inspection procedure

Check point	No.	Check item	Description			
Undervoltage trip device (UVT) See 6-2-1.	1	Coil resistance	Disconnect hand connector (red) and, using tester, measure coil resistance between terminals and make sure holding coil is rated at 410 - 510 Ω and attraction coil at 5.6 - 6.8Ω. (*) If not so, replace UVT.			
	2	Operation	Remove UVT and press in plunger, and make sure releasing plunger causes plunger to be smoothly restored. If not so, replace UVT.			
	3	Length and stroke of plunger	Remove UVT and, using vernier caliper, make sure plunger length is 32.5 - 33.5mm in natural state and plunger stroke is 6.5 - 7.5 mm. If not so, replace UVT.			
	4	Hand connector	Check that hand connector (red) is connected to ACB hand connector (red) correctly. If incorrect, connect correctly.			
	5	Looseness of screws	Check UVT mounting screws for looseness. If loose, retighten.			
Contacts See 6-2-2, 6-2-3 and 6-2-4	6	Parting distance	With ACB open, remove arc chamber and, using compass and vernier caliper, make sure distance between moving and stationary contact tips falls within the following ranges. If not so, replace both moving and stationary contacts. If it is useless to replace contacts, contact us.			
			Distances between moving and stationary contact tips (mm)			
			Line side		Load side	
			phase A-C	phase N	phase A-C	phase N
	AR208S, AR212S, AR216S, AR220S, AR325S, AR332S, AR440S(3P)	17-20.5	16-20	17-20.5	16-20	
AR440S(4P)	17-21.5	17-21.5	17-21.5	17-21.5		
AR212H, AR216H, AR220H, AR316H, AR320H, AR325H, AR332H	17-20.5	16-20	16-20	16-20		
7	Engagement	Insert 3.5 - 4.0-mm-dia x 50-mm-length rod into engagement measuring hole vertically until it stops, and measure protrusion of rod when ACB is open and closed. Make sure difference in protrusion is following: line side; 2.7-3.4mm, load side; 2.7-4.0mm. (The difference of the value of line side and load side must not exceed 1.0mm.) If not so, replace both moving and stationary contacts. If it is useless to replace contacts, contact us.				
Current sensors See 6-2-3.	8	Looseness of screws	Check current sensor mounting screws for looseness. If loose, retighten.			
Latch release coil (LRC) See 6-2-5.	9	Coil resistance	Disconnect hand connector (green) that is closer to coil than the other and, using tester, measure coil resistance between terminals and make sure it is within range specified in Table 10. (*) If not so, replace LRC.			
	10	Length and stroke of plunger	Remove LRC and, using vernier caliper, make sure plunger length is 24.2 - 24.8 mm in natural state and protrusion of plunger is 6.3 - 7 mm when moving core is pushed in. If not so, replace LRC.			
	11	Hand connector	Check that hand connector (green) is connected to ACB hand connector (green) correctly. If incorrect, connect correctly.			
	12	Looseness of screws	Check LRC mounting screws for looseness. If loose, retighten.			
	13	Mechanical motion	With closing springs charged, check that pushing moving core results in ACB being closed slowly, and releasing moving core results in the core being restored smoothly. If not so, replace LRC. If it is useless to replace LRC, contact us. After inspection, open ACB and discharge closing springs.			
Shunt trip device (SHT) See 6-2-6.	14	Coil resistance	Disconnect hand connector (black) that is closer to coil than the other and, using tester, measure coil resistance between terminals and make sure it is within range specified in Table 11. (*) If not so, replace SHT.			
	15	Length and stroke of plunger	Remove SHT and, using vernier caliper, make sure plunger length is 24.2 - 24.8 mm in natural state and protrusion of plunger is 6.3 - 7 mm when moving core is pushed in. If not so, replace SHT.			
	16	Hand connector	Check that hand connector (black) is connected to ACB hand connector (black) correctly. If incorrect, connect correctly.			
	17	Looseness of screws	Check SHT mounting screws for looseness. If loose, retighten.			
	18	Mechanical motion	With ACB closed, check that pushing moving core results in ACB being opened slowly, and releasing moving core results in the core being restored smoothly. If not so, replace SHT. If it is useless to replace SHT, contact us. After inspection, discharge closing springs.			
Magnet hold trigger (MHT) See 6-2-8.	19	Coil resistance	Disconnect hand connector (red) and, using tester, measure coil resistance between terminals and make sure it is 1.8 - 2.2 Ω. (*) If not so, replace MHT.			
	20	Operation	Remove MHT and pull out moving core slowly, and make sure pushing moving core allows core to be smoothly retracted and attracted. If not so, replace MHT.			
	21	Length and stroke of moving core	Remove MHT and, using vernier caliper, make sure protrusion of moving core is 6.7 - 7.3mm in pulled-out state. If not so, replace MHT.			
	22	Hand connector	Check that hand connector (red) is connected to ACB hand connector (red) correctly. If incorrect, connect correctly.			
	23	Looseness of screws	Check MHT mounting screws for looseness. If loose, retighten.			
Charging motor and LRC	24	Electrical operation	With breaker body assembled to original state, move breaker body to TEST position, supply ACB with operation power, and attempt to perform motor charging and electrical closing operation with max. and min. voltages within permissible charging/closing voltage range to make sure ACB operates normally. (See Table 10). If ACB does not operate normally, contact us.			
SHT	25	Electrical operation	With breaker body assembled to original state, move breaker body to TEST position, close ACB, supply SHT with power, and attempt to perform electrical opening operation with max. and min. voltages within permissible closing voltage range to make sure ACB trips open normally. (See Table 11). If ACB does not trip open, contact us.			
UVT	26	Electrical operation	With breaker body assembled to original state, move breaker body to TEST position, charge closing springs, and make sure that ACB closes when UVT is supplied with attraction power. And decrease UVT supply voltage to make sure ACB opening voltage is within specified opening voltage range. (See Table 12.) If ACB does not operate normally, contact us.			
OCR and MHT	27	Operation	With the breaker body assembled to the original state, perform the "OCR + ACB" test described in 5-5 to make sure ACB operates normally. If ACB does not operate normally, contact us.			

● Always check the "General" items in Table 34 during the inspection procedure shown in Table 35 above.

* Take care to avoid damaging or deforming terminal pins when bringing tester lead into contact with them.

6-2. Parts Replacement Procedure

⚠ CAUTION

- ACB maintenance, inspection and parts replacement must be performed by competent persons.
- Do not touch ACB current carrying parts and ACB structural parts close to a current carrying part immediately after the ACB trips open. Remaining heat may cause a burn.
- Prior to commencing any work on the ACB, open an upstream circuit breaker or the like to isolate all sources of power/voltage from the main and control circuits. Otherwise, electric shock may result.
- Take care to avoid adhesion of dust to main and control circuit contacts. Dust on the contacts may result in a fire.
- Prior to commencing maintenance, inspection, or parts replacement, make sure that the closing springs are released and the ACB is open. Otherwise, unintentional open/close operation may lead to fingers or tools to be pinched by the open/close mechanism, resulting in injury.
- Be sure to reinstall the arc chamber if removed. Failure to do so or incorrect installation of the arc chamber may result in a fire or burn.
- When replacing an auxiliary, do not damage the control wire for the auxiliary or pinch the wire between the auxiliary and the breaker body. Doing so may cause a malfunction.

6-2-1. Preparation

Be sure to make the following preparations for parts replacement in order to ensure safety.

- 1) Open an upstream circuit breaker or the like to isolate all sources of power/voltage from the main and control circuits.
- 2) Draw out the breaker body to the removed position, and remove it using an optional lifter or lifting plate. Refer to sections 4-2-2 and 2-1-2.
- 3) Discharge the closing springs and open the ACB. The procedure varies depending on whether or not the ACB is equipped with the undervoltage trip device (UVT).

- When the ACB is not equipped with the undervoltage trip device (UVT):

Perform manual closing/opening operation of the ACB. Refer to sections 4-1-2 and 4-1-3.

- When the ACB is equipped with the undervoltage trip device (UVT):

- (1) Turn the cover mounting screws five or six turns to loosen as shown in Fig. 56. If the ACB is equipped with side covers, first remove the side covers and then loosen the front cover mounting screws. (The cover mounting screws are of captive type and cannot be removed from the side and front covers.)

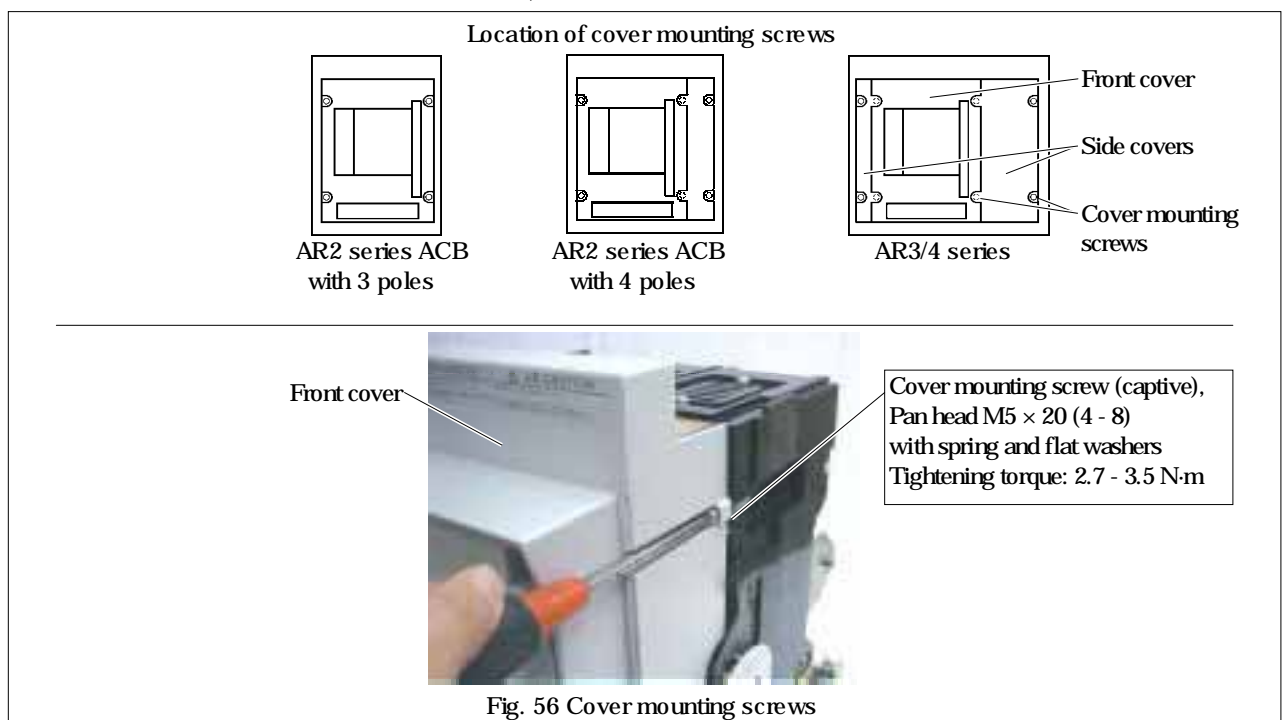

(2) Remove the contact block fixing screws as shown in Fig. 57.



(3) Slide the front cover to the left and flip the contact block up as shown in Fig. 58.

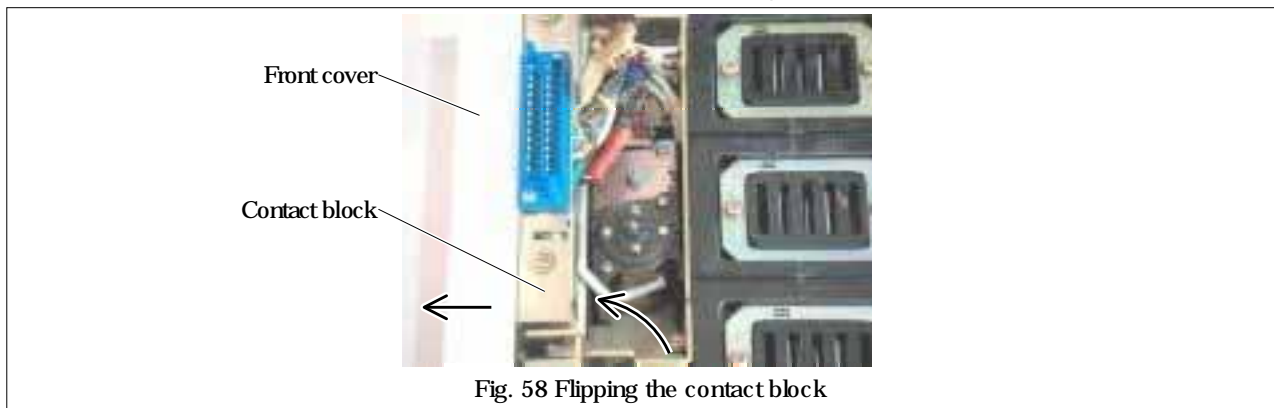

(4) Turn the UVT mounting screws eight or ten turns to loosen, disconnect the manual connector (red), and then remove the UVT as shown in Fig. 59.

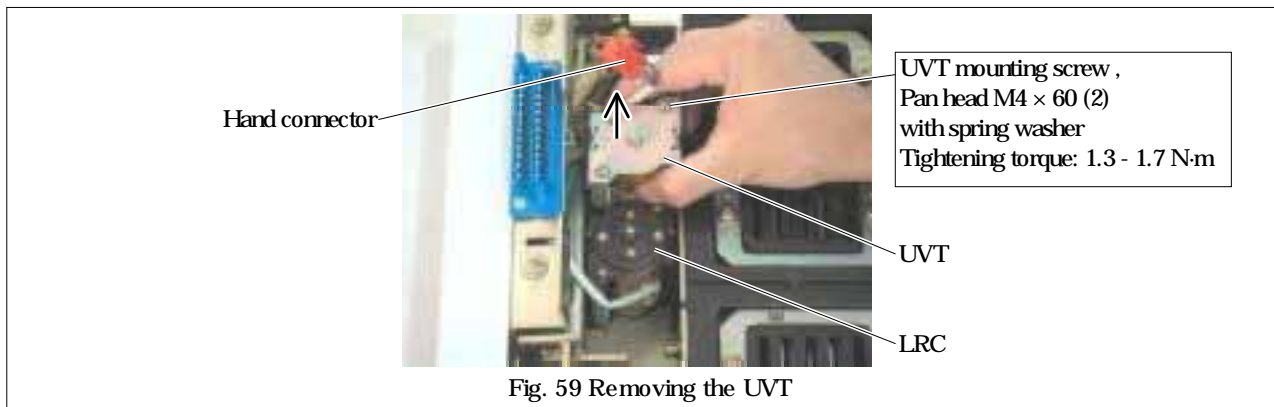

(5) Flip the contact block down and slide the front cover to the original position as shown in Fig. 60.

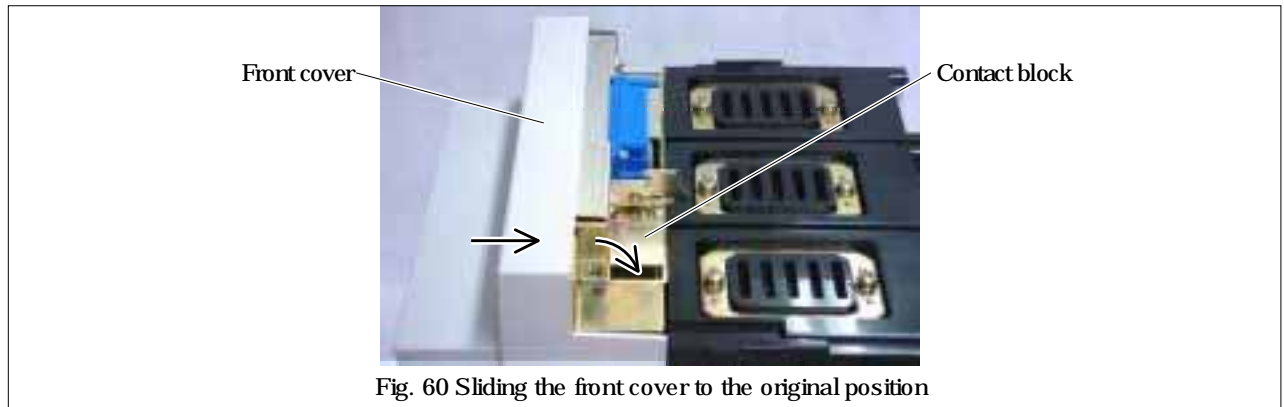

(6) Perform manual closing/opening operation of the ACB. Refer to sections 4-1-2 and 4-1-3.

(7) Reinstall each part or component in reverse order of removal after inspection. When installing the UVT, make sure the nameplate on the UVT can be viewed from the front of the ACB.

● Fig. 61 provides the general view of the UVT.

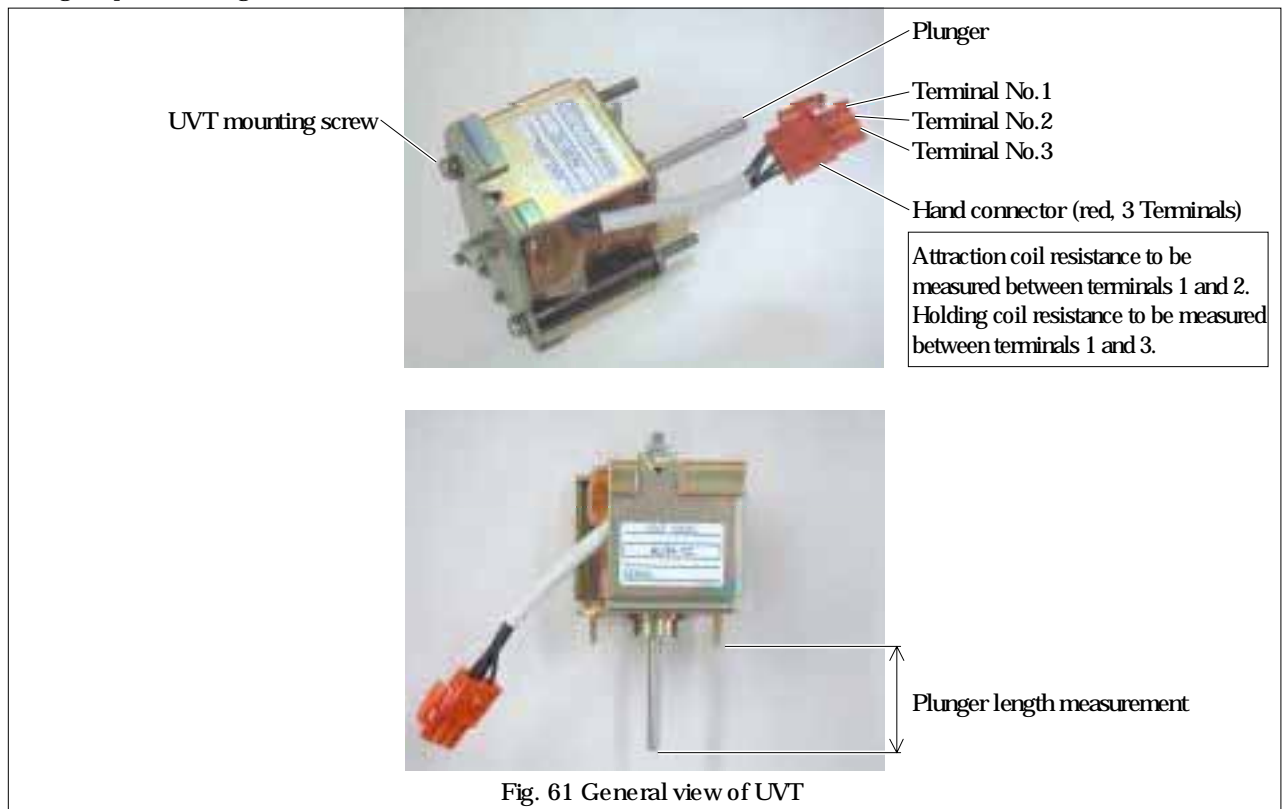

6-2-2. Arc chambers

The following describes how to replace arc chambers.

- 1) Make preparations for parts replacement. Refer to section 6-2-1.
- 2) Carefully lay the breaker body on spacers with the backside down as shown in Fig. 62. The spacers must be at least 7-cm high to prevent deformation of protrusions on the breaker body backside, and have the size and strength that allow the breaker body to be safely laid on them. Take care to keep the main circuit contacts clean of dust.

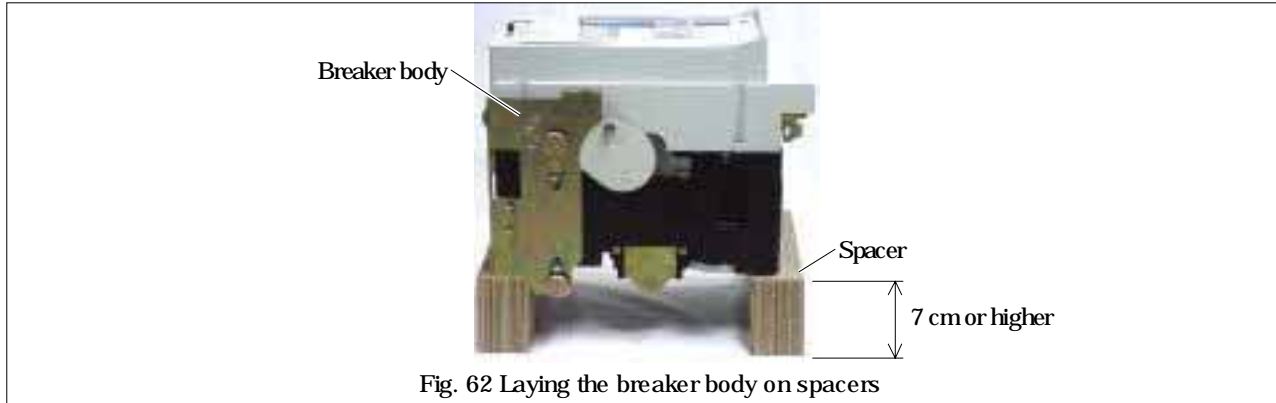

- 3) Turn the arc chamber mounting screw eight or ten turns to loosen as shown in Fig. 63. (The arc chamber mounting screws are of captive type and cannot be removed from the arc chamber.)

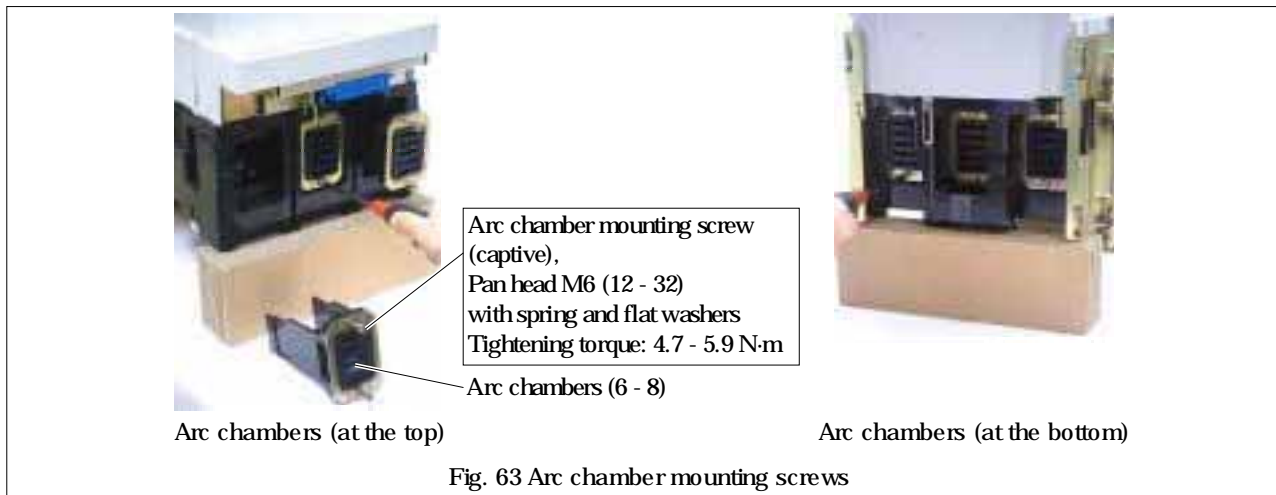

- 4) Holding the arc chamber mounting screw, remove the arc chamber.
 - 5) Reinstall each part or component in reverse order of removal after inspection.
- Fig. 64 shows a removed arc chamber.



6-2-3. Stationary contact

The following describes how to replace the stationary contact. Fig. 65 shows the general view around the stationary contact.

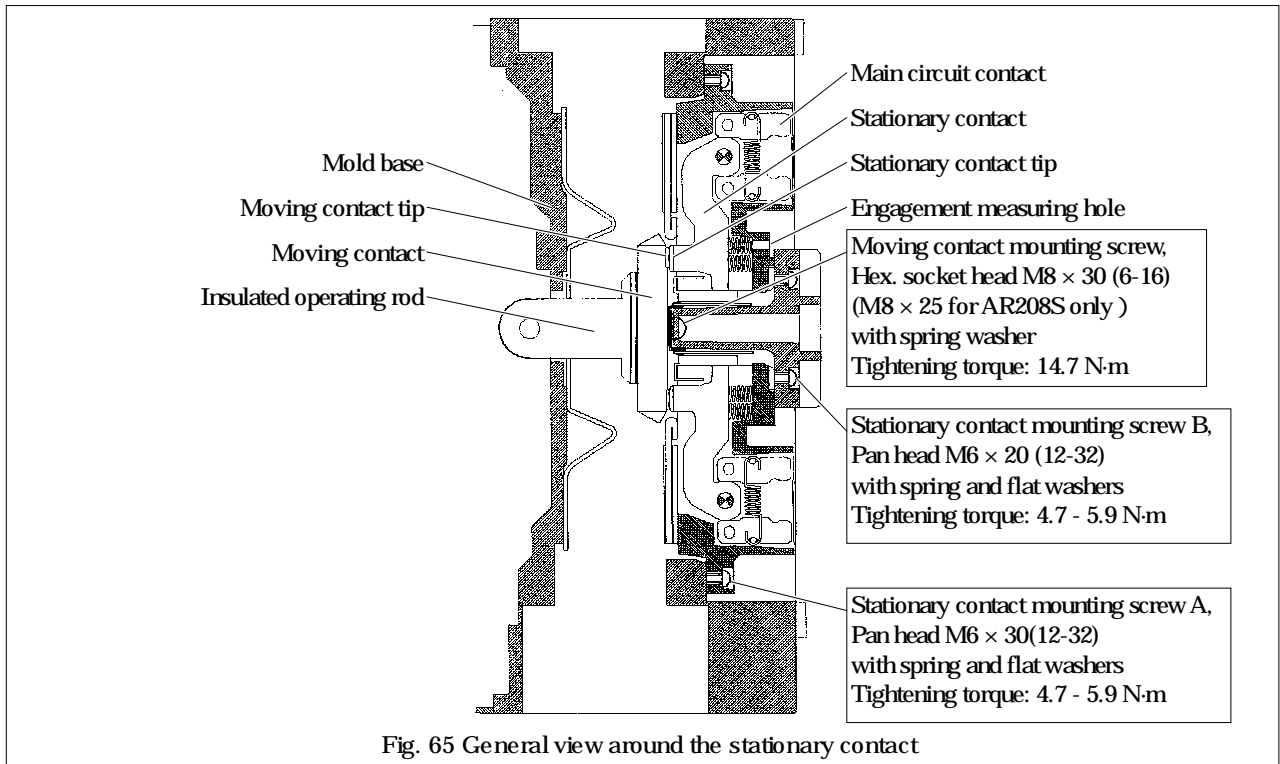

- 1) Make preparations for parts replacement. Refer to section 6-2-1.
- 2) Unscrew the current sensor mounting screws and remove the current sensor and the power supply CT located behind the sensor. Take care not to exert undue force on the control wire between the current sensor and the power supply CT. To remove the current sensor, hold the top of the sensor; then tilt and pull it out in a slanting direction as shown in Fig. 66.

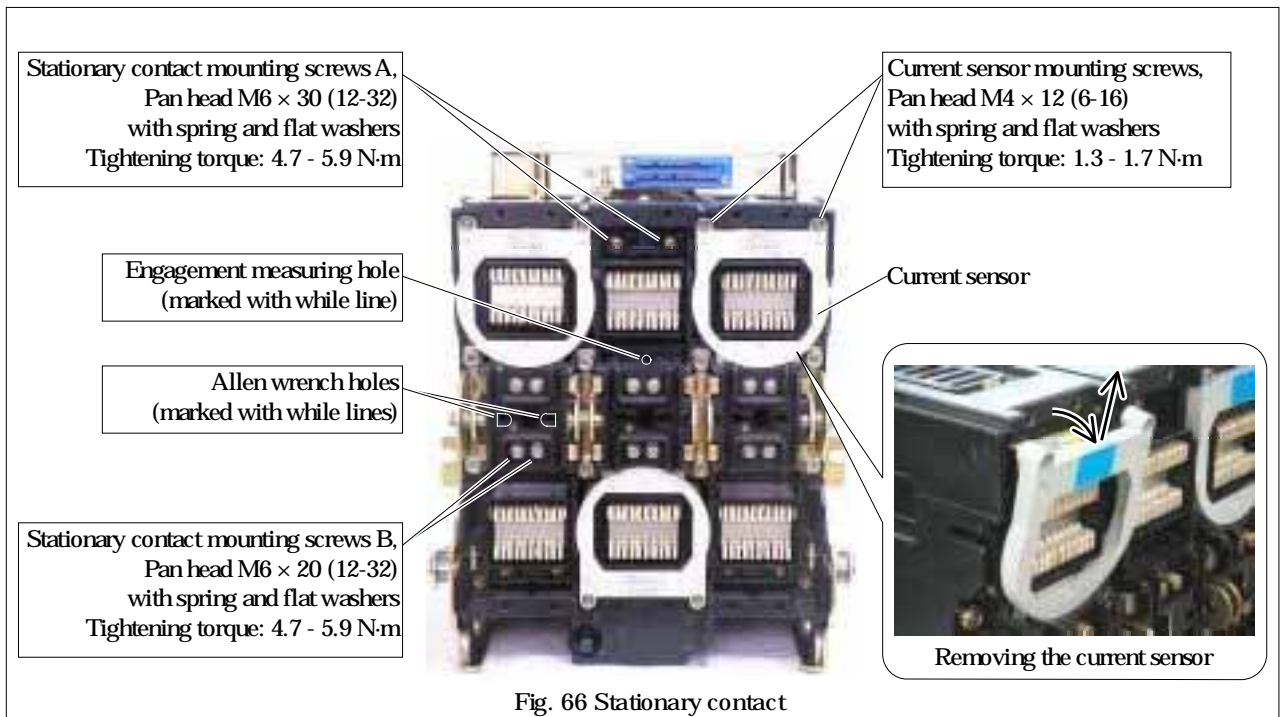

- 3) Unscrew stationary contact mounting screws A and B.

- 4) Tilt and remove the stationary contact as shown in Fig. 67. (The insulation sheet will be removed at the same time.) If the current sensor and power supply CT hinder the removal of the stationary contact, make a record of the ties for control wires between the current sensor and power supply CT (position/number of ties and type of control wires) using a digital camera, then cut the ties and remove the stationary contact. Restore the ties after replacing the stationary contact.

Ties: TYTON Insulok T18RHS (heat resistance grade: HS, 100 mm long x 2.5 mm wide) or equivalent (2 or 3 pcs per pole)

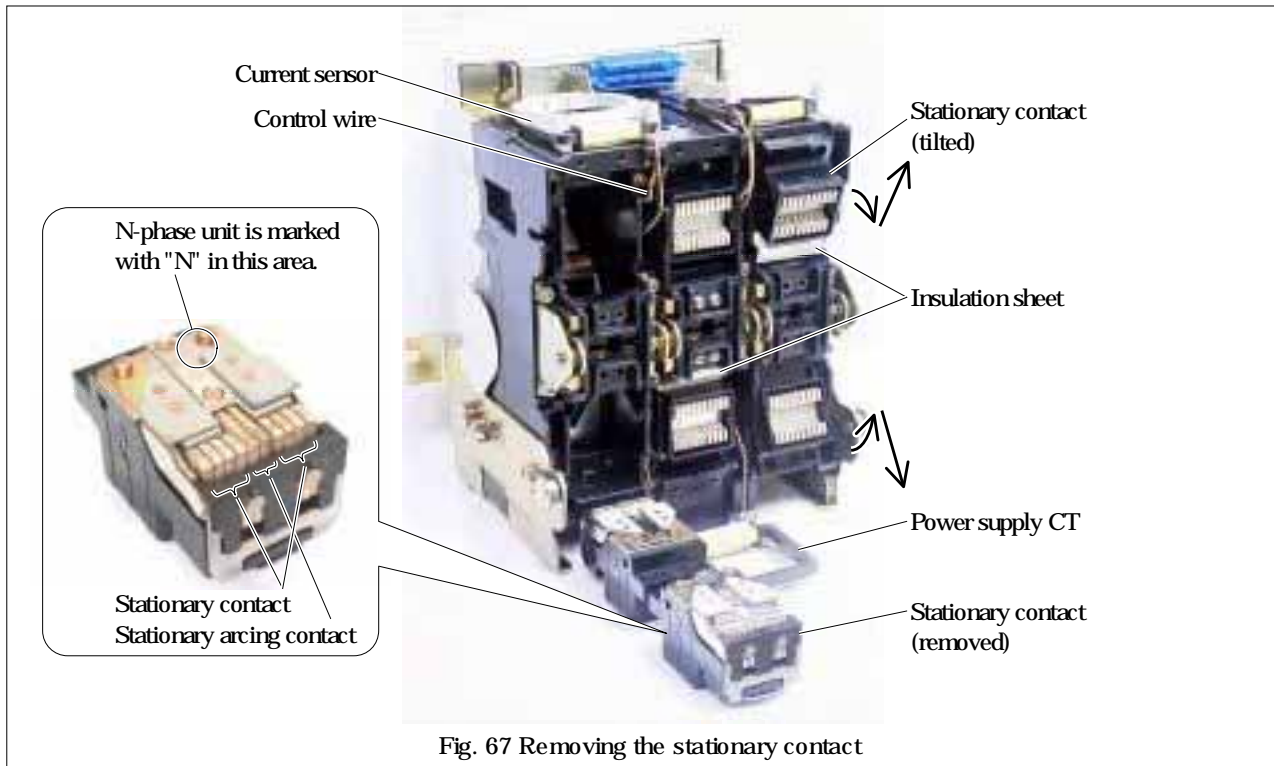

Fig. 67 Removing the stationary contact

- 5) Reinstall each part or component in reverse order of removal after inspection. Make sure the insulation sheet is installed. Be sure to restore the ties if they have been cut during removal of the stationary contact.
- 6) After installing the moving and/or stationary contact, be sure to perform 10 - 20 cycles of open/close operation and then retighten the contact mounting screws to the specified torque.

● Fig. 68 shows the contacts in closed and open state.

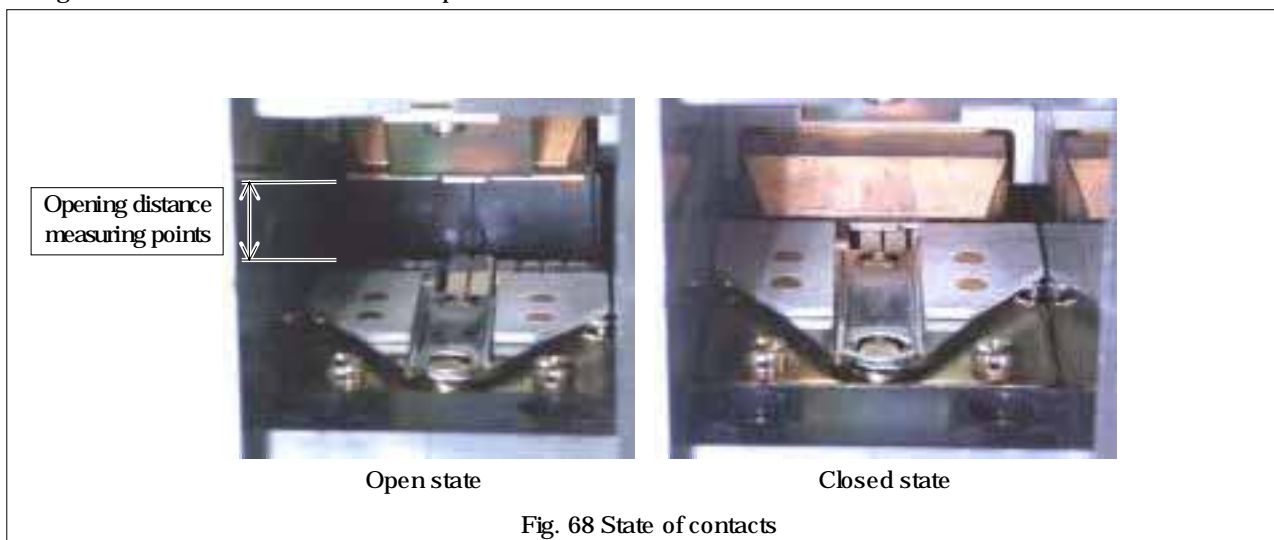
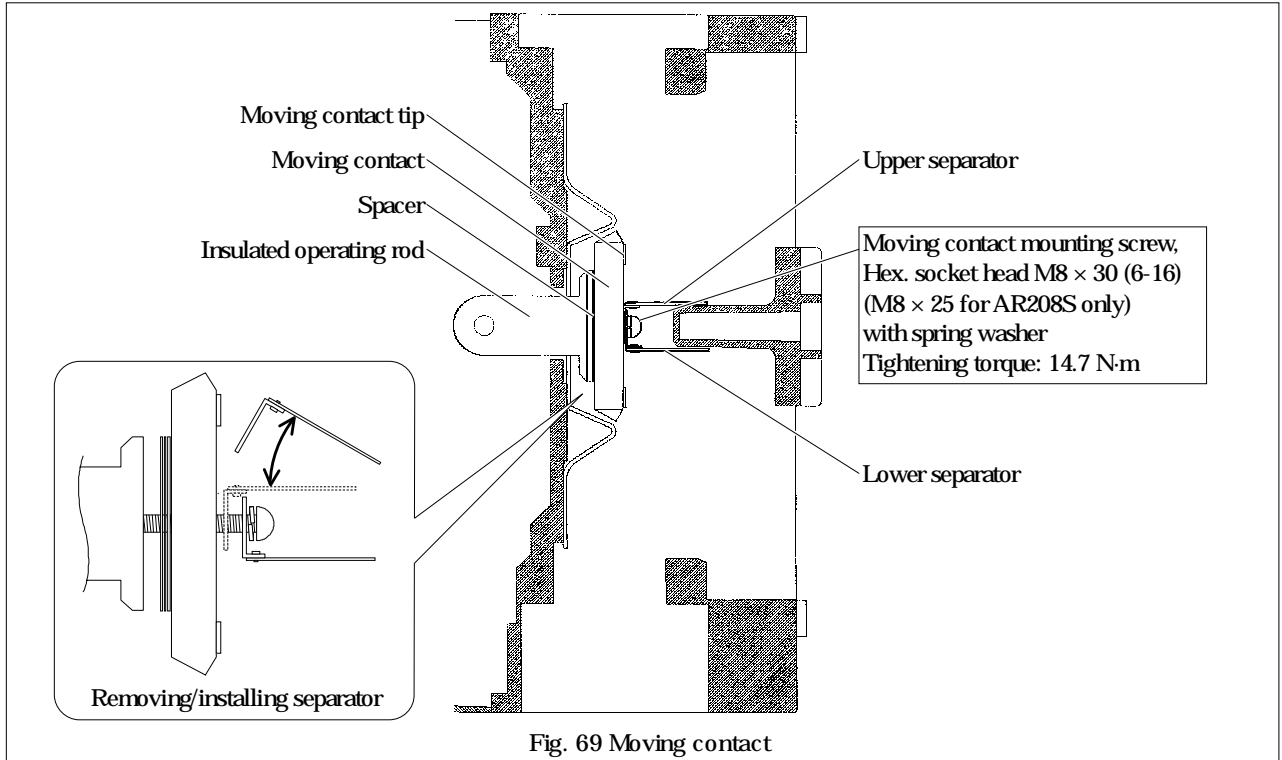

Fig. 68 State of contacts

6-2-4. Moving contact

The following describes how to replace the moving contact.

- 1) Make preparations for parts replacement. Refer to section 6-2-1.
- 2) Remove the arc chambers and stationary contact. Refer to sections 6-2-2 and 6-2-3.
- 3) Insert an Allen wrench of a nominal diameter of 5 into each of the Allen wrench holes shown in Fig. 66, turn each moving contact mounting screw two or three turns to loosen, and raise and remove the upper separator shown in Fig. 69.



- 4) Supporting the spacers (the number of which varies depending on the poles), the moving contact, the lower separator, and the moving contact mounting screws by hand, turn the moving contact mounting screws additional two or three turns to remove these parts. Fig. 70 shows the moving contact-related parts.

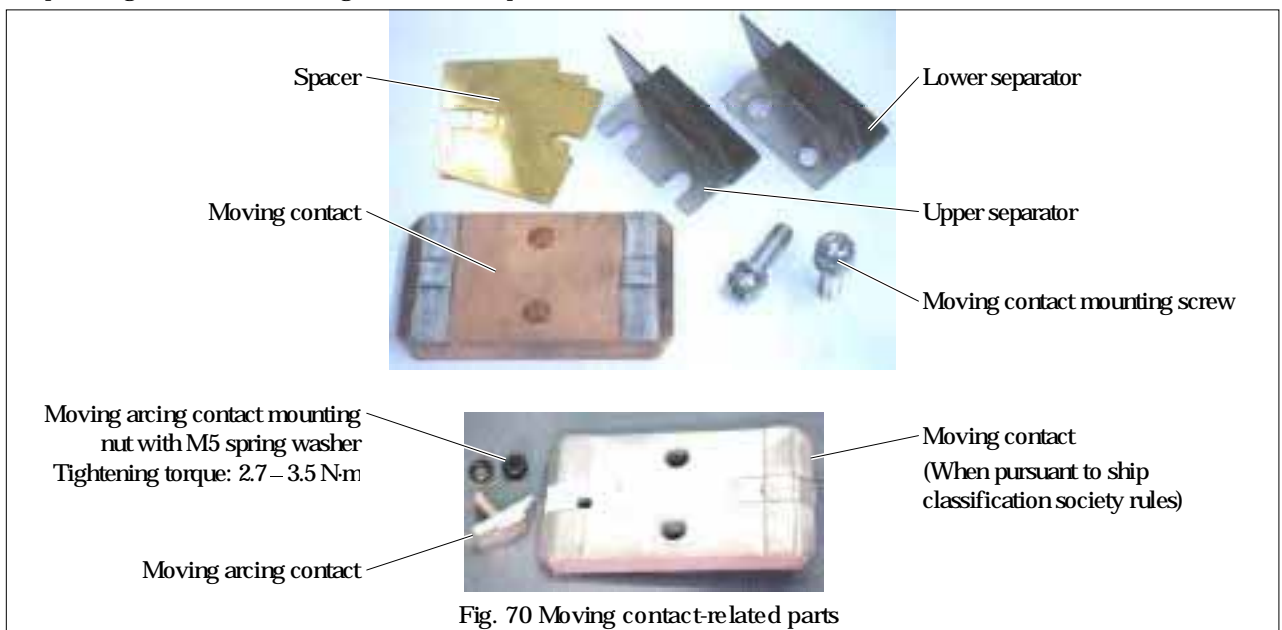

- 5) Reinstall each part or component in reverse order of removal after inspection. As to the moving contact-related parts, however, install the spacer, moving contact, upper separator, lower separator, spring washer and moving contact mounting screw in this order, beginning with the side of insulated operation rod. See Fig. 69.
- 6) After installing the moving and/or stationary contact, be sure to perform 10 - 20 cycles of open/close operation and then retighten the contact mounting screws to the specified torque.

6-2-5 Latch release coil (LRC)

The following describes how to replace the latch release coil (LRC).

- 1) Make preparations for parts replacement. Refer to section 6-2-1.
- 2) If the ACB is not equipped with the fixed type undervoltage trip device, turn the cover mounting screws five or six turns to loosen as shown in Fig. 56. If the ACB is equipped with side covers, first remove the side covers and then loosen the front cover mounting screws. (The cover mounting screws are of captive type and cannot be removed from the side and front covers.)
- 3) Pulling the charging handle down, remove the front cover.
- 4) Remove the contact block fixing screws as shown in Fig. 57.
- 5) Flip the contact block up as shown in Fig. 58.
- 6) Turn the LRC mounting screws eight or ten turns to loosen, disconnect the manual connector (green), and then remove the LRC. See Fig. 71.

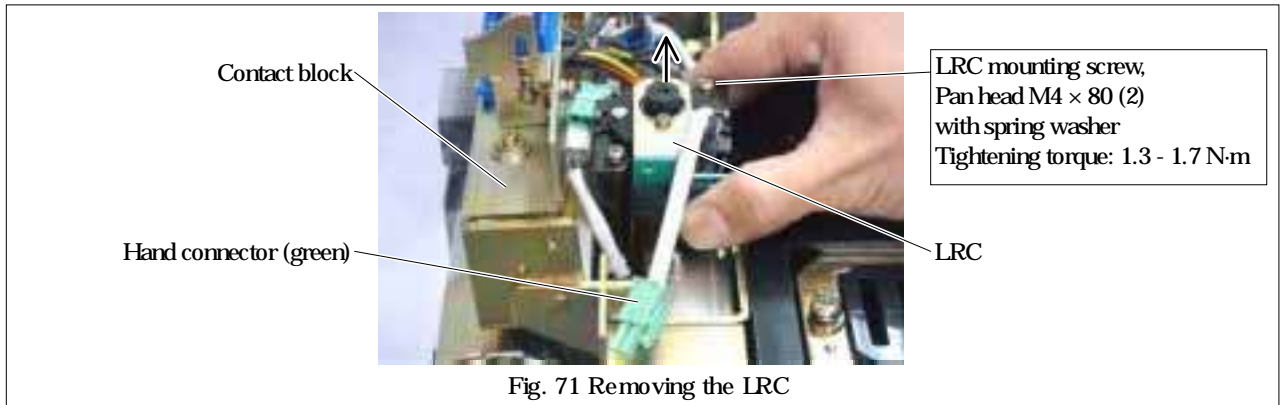

- 7) Reinstall each part or component in reverse order of removal after inspection. When installing the LRC, make sure the nameplate on the LRC can be viewed from the front of the ACB.
- Fig. 72 provides the general view of the LRC.

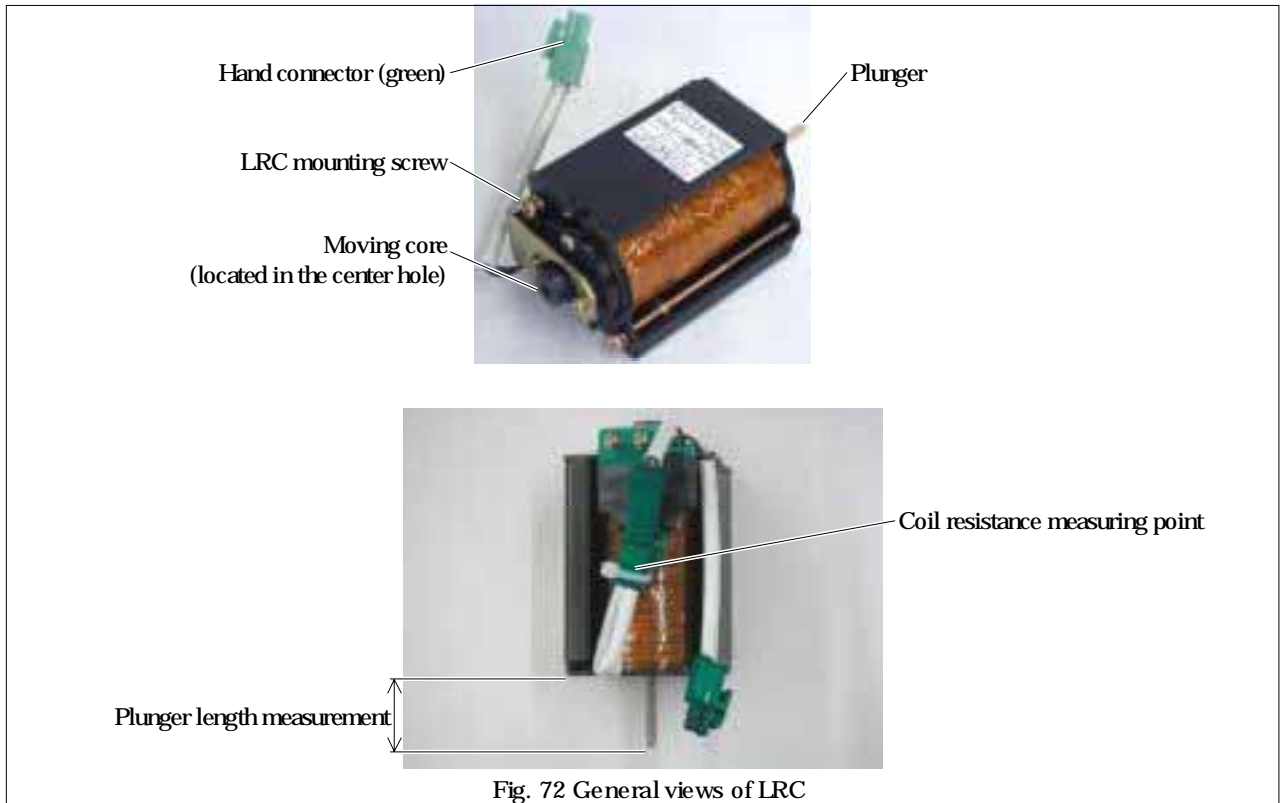

6-2-6. Shunt trip device (SHT)

The following describes how to replace the shunt trip device(SHT).

- 1) Make preparations for parts replacement. Refer to section 6-2-1.
- 2) Turn the cover mounting screws five or six turns to loosen as shown in Fig. 56. If the ACB is equipped with side covers, first remove the side covers and then loosen the front cover mounting screws. (The cover mounting screws are of captive type and cannot be removed from the side and front covers.)
- 3) Pulling the charging handle down, remove the front cover.
- 4) Remove the contact block fixing screws as shown in Fig. 57.
- 5) Flip the contact block up as shown in Fig. 58.
- 6) Turn the SHT mounting screws eight or ten turns to loosen, disconnect the manual connector (black), and then remove the SHT.
See Fig. 73.

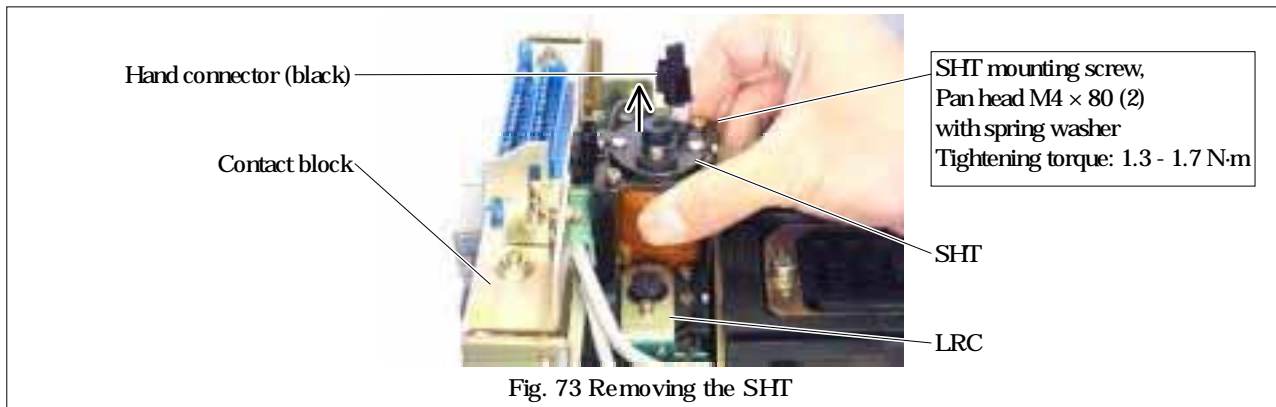

Fig. 73 Removing the SHT

- 7) Reinstall each part or component in reverse order of removal after inspection. When installing the SHT, make sure the nameplate on the SHT can be viewed from the front of the ACB.

● Fig. 74 provides the general view of the SHT.

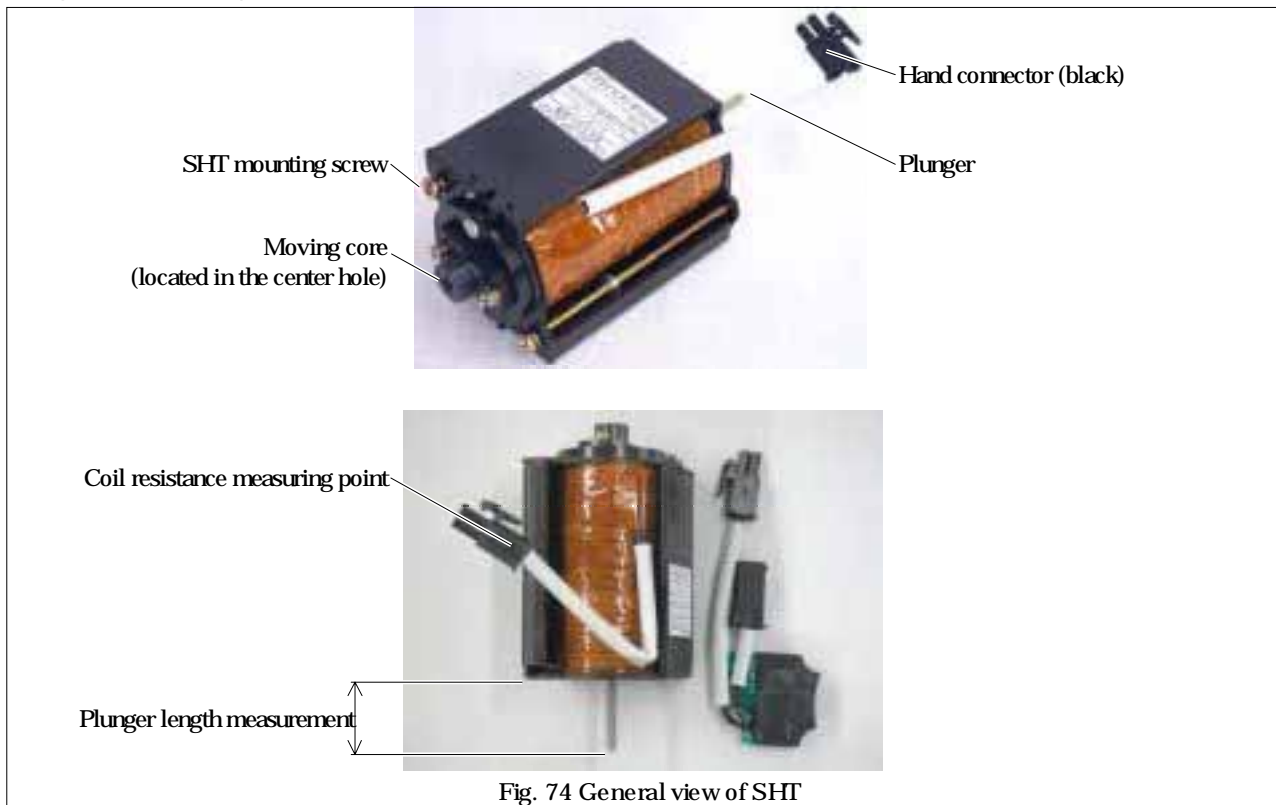
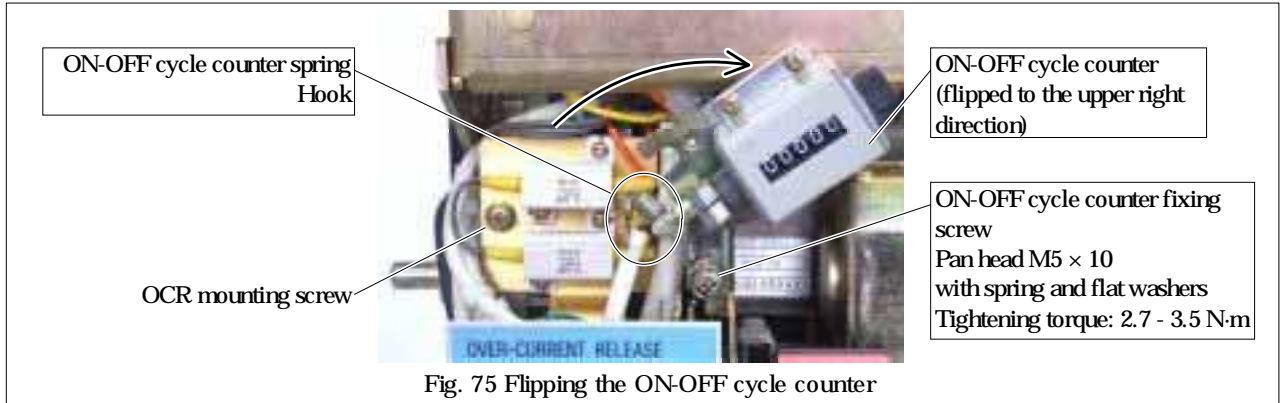

Fig. 74 General view of SHT

6-2-7. Control relay

The following describes how to replace the control relay.

- 1) Make preparations for parts replacement. Refer to section 6-2-1.
- 2) If the ACB is not equipped with the fixed type undervoltage trip device, turn the cover mounting screws five or six turns to loosen as shown in Fig. 56. If the ACB is equipped with side covers, first remove the side covers and then loosen the front cover mounting screws. (The cover mounting screws are of captive type and cannot be removed from the side and front covers.)
- 3) Pulling the charging handle down, remove the front cover:
- 4) If the ACB is equipped with the ON-OFF cycle counter, disengage the hook located under the cycle counter spring, turn the cycle counter fixing screw two or three turns to loosen (do not remove), and flip the cycle counter up to the upper right direction. See Fig. 75.



- 5) Unscrew the OCR mounting screws and remove the wiring from the wire tie. See Fig. 76.

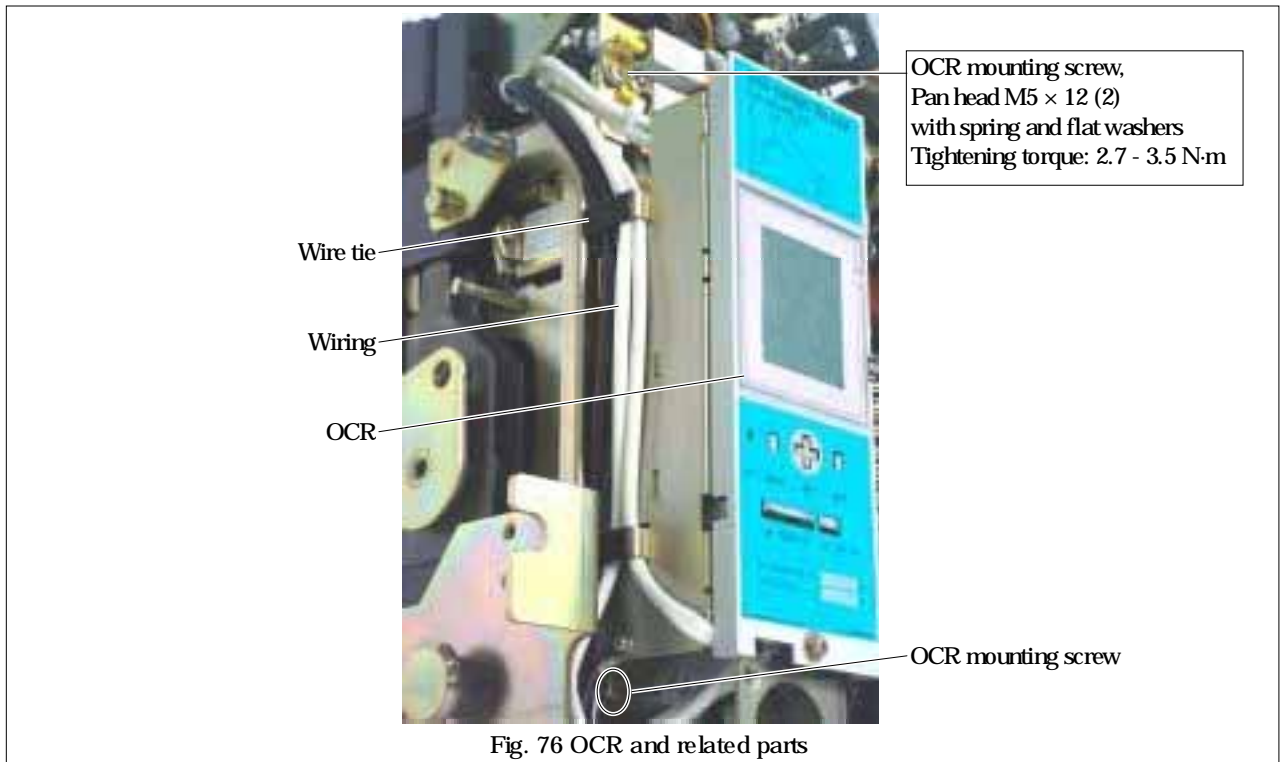

- 6) Pull out the OCR as shown in Fig. 77, remove the hand connector(s) above the OCR and place it on the floor. The hand connector(s) below the OCR does not require to be removed. The type and quantity of the hand connectors vary depending on the specification of the ACB.

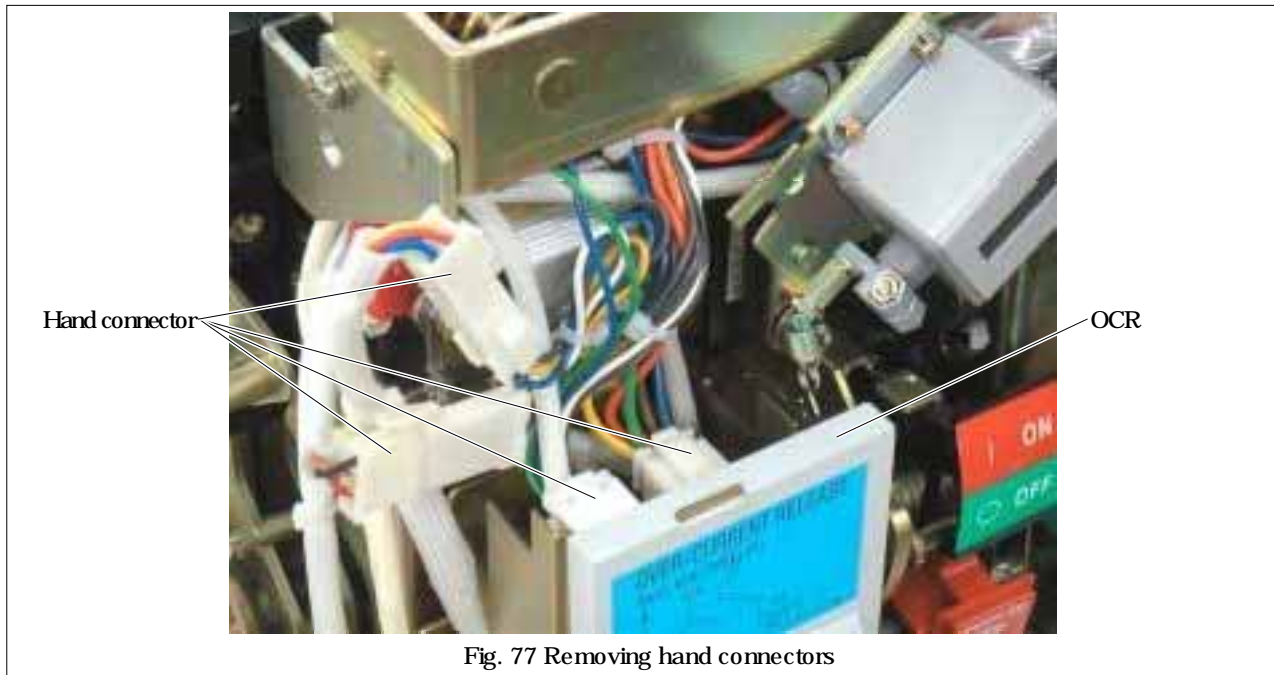

Fig. 77 Removing hand connectors

- 7) Unscrew the contact block mounting screws as shown in Fig. 57 and flip the contact clock up as shown in Fig. 58.
- 8) Unscrew relay base mounting screws A and B, raise the relay base to unlatch from other parts, remove the base and place it on the top of the breaker body. To remove relay base mounting screw B, use a ball end type 4-mm Allen wrench. See Fig. 78.
- When relay base mounting screw A, the relay base ground terminal will also be removed.

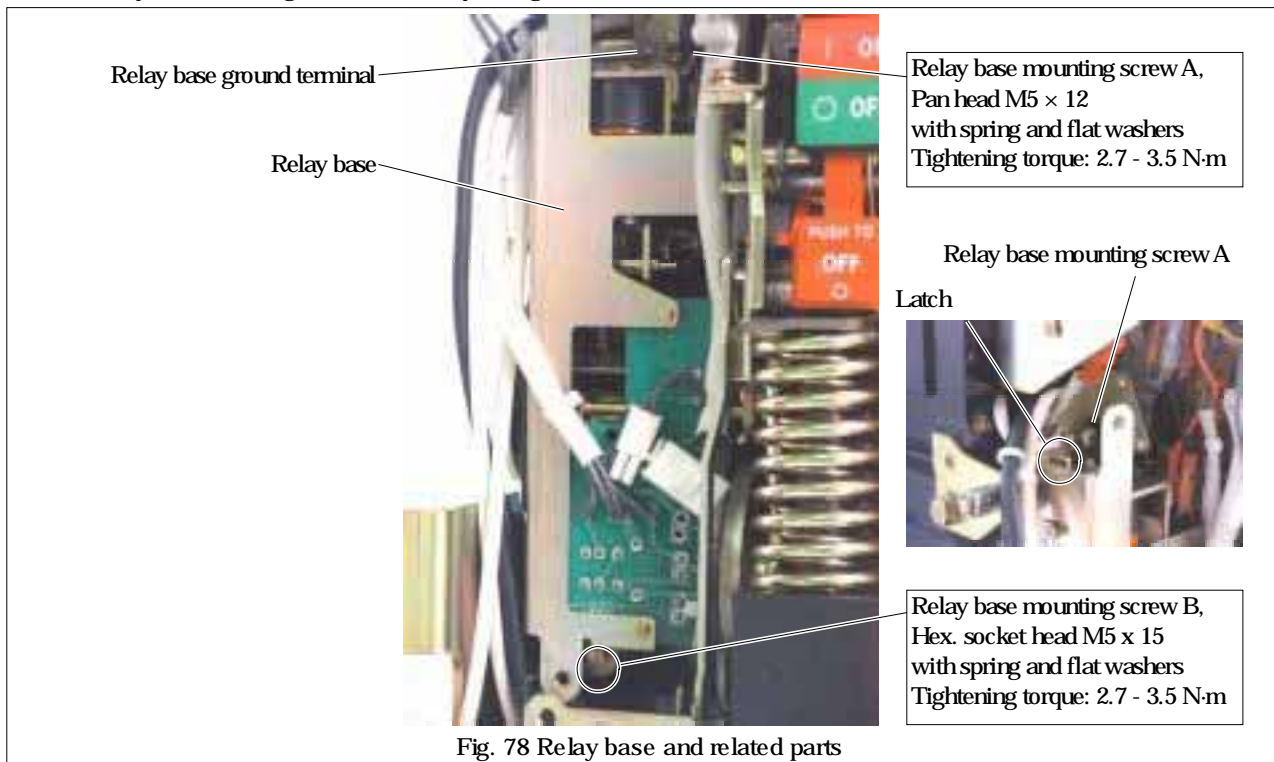

Fig. 78 Relay base and related parts

9) Remove the relay retainer shown in Fig. 79 and remove the control relay from the relay base.

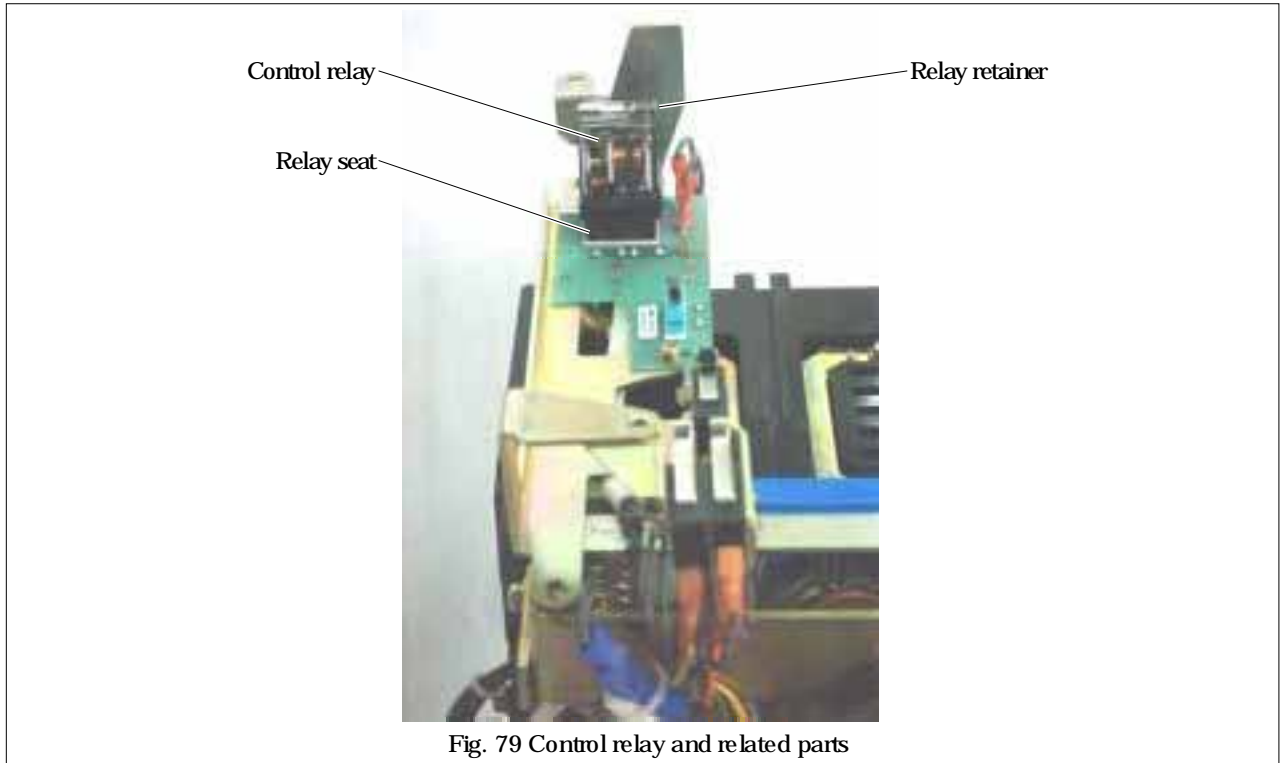

Fig. 79 Control relay and related parts

10) Reinstall each part or component in reverse order of removal after inspection. Do not forget to install the OCR ground terminal and the relay base ground terminal.

6-2-8. Magnet hold trigger (MHT)

The following describes how to replace the magnet hold trigger (MHT).

- 1) Make preparations for parts replacement. Refer to section 6-2-1.
- 2) Remove the OCR and the relay base. Refer to items 2 - 8, section 6-2-7.
- 3) Unscrew the MHT mounting screws shown in Fig. 80, disconnect the hand connector (red), and remove the MHT.

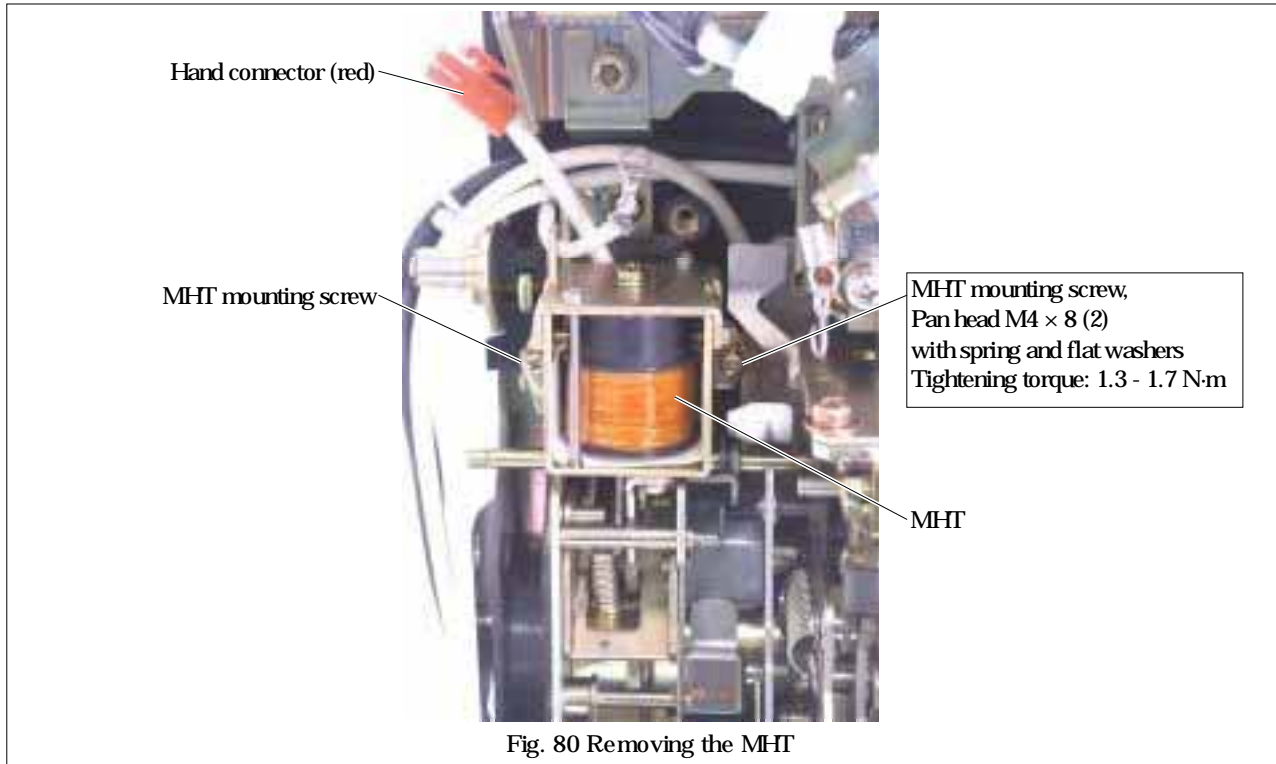

- 4) Reinstall each part or component in reverse order of removal after inspection.

● Fig. 81 provides the general view of the MHT.

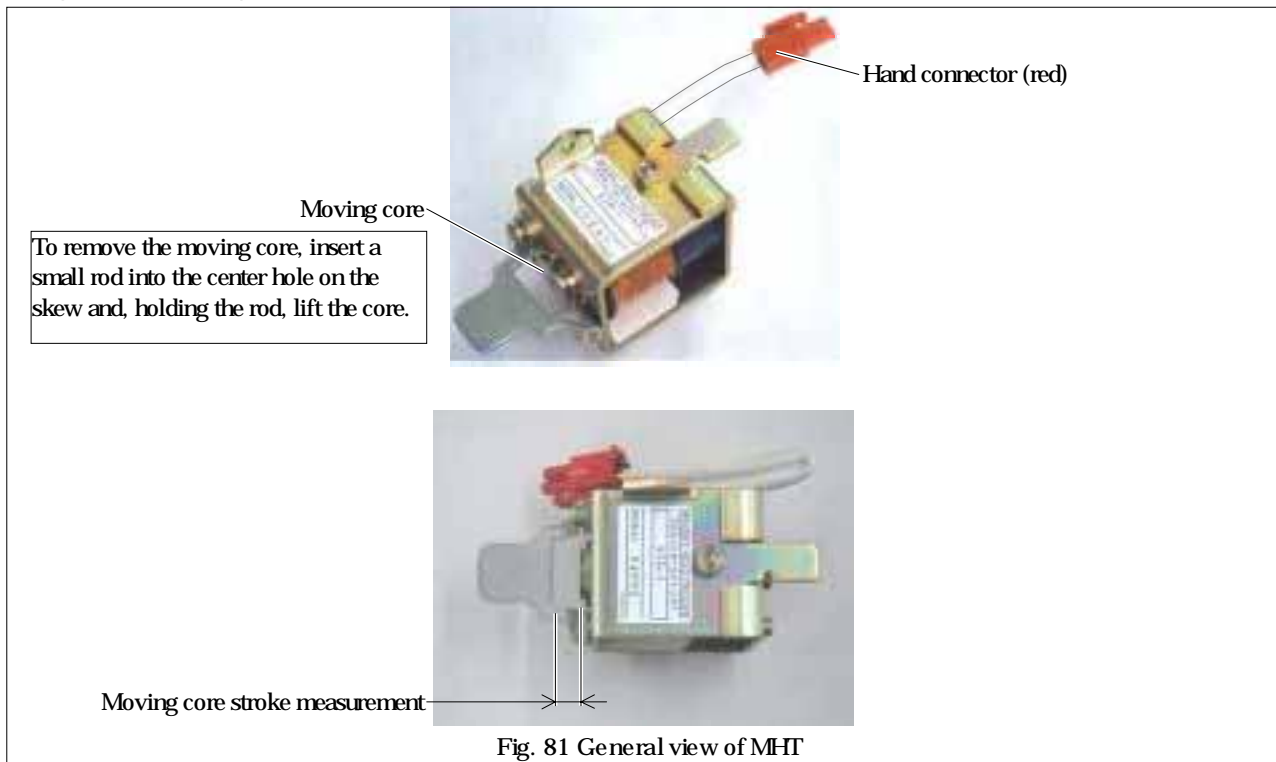

6-2-9. Auxiliary switches

The following describes how to replace auxiliary switches.

- 1) Make preparations for parts replacement. Refer to section 6-2-1, 1) and 2).
- 2) If the ACB is equipped with the control terminal block cover, loosen both the cover fixing screws and remove the cover.
- 3) Remove the auxiliary switch mounting screws shown in Fig. 82.

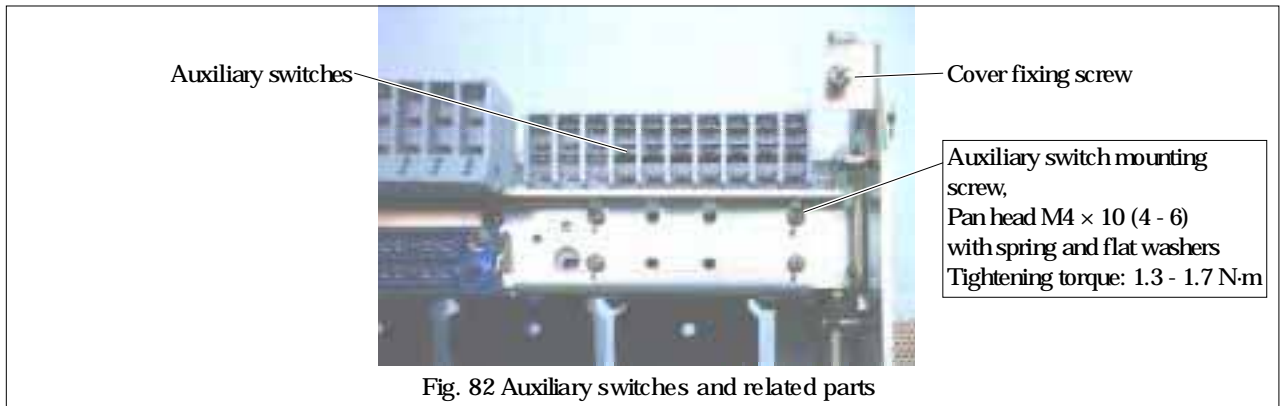

- 4) Depressing the AUX lock lever shown in Fig. 83, raise the operation lever.

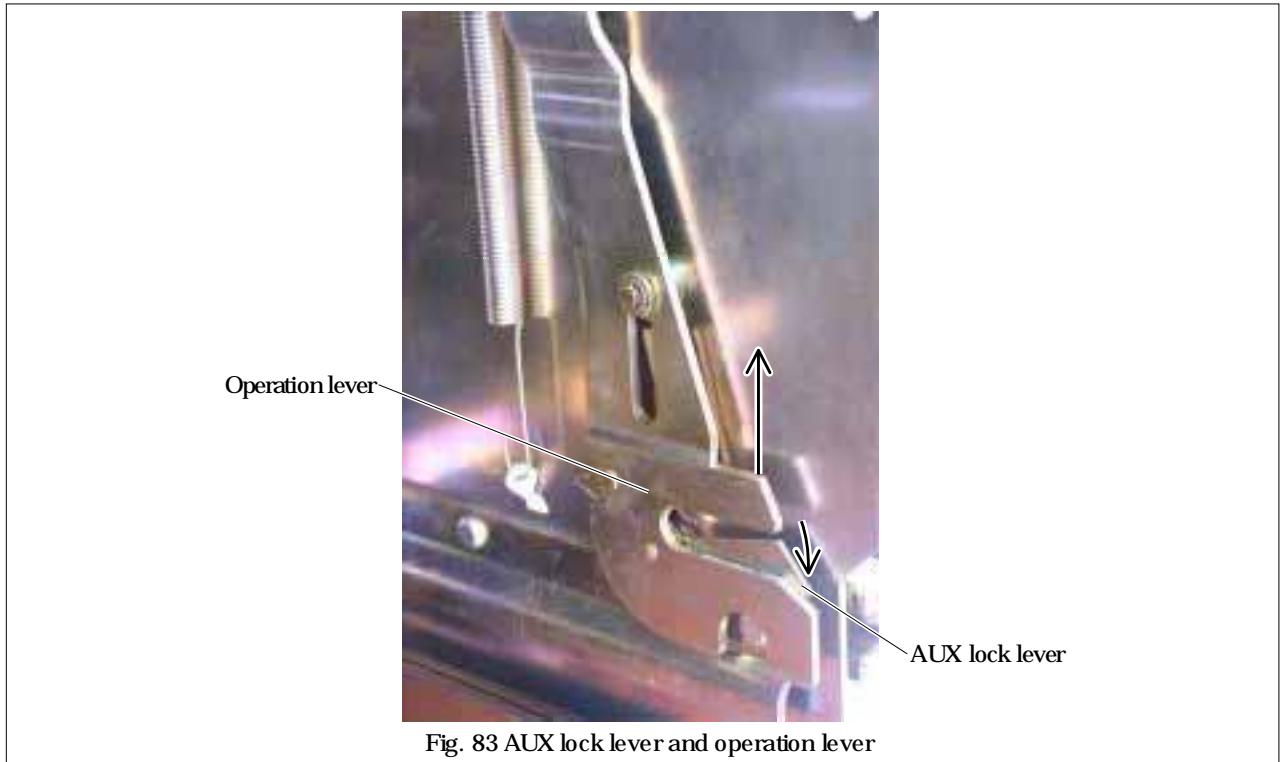

5) With the operation lever raised, uplift the auxiliary switch unit, pull the shaft lever through the U-notch, and remove the auxiliary switch unit. See Fig. 84.

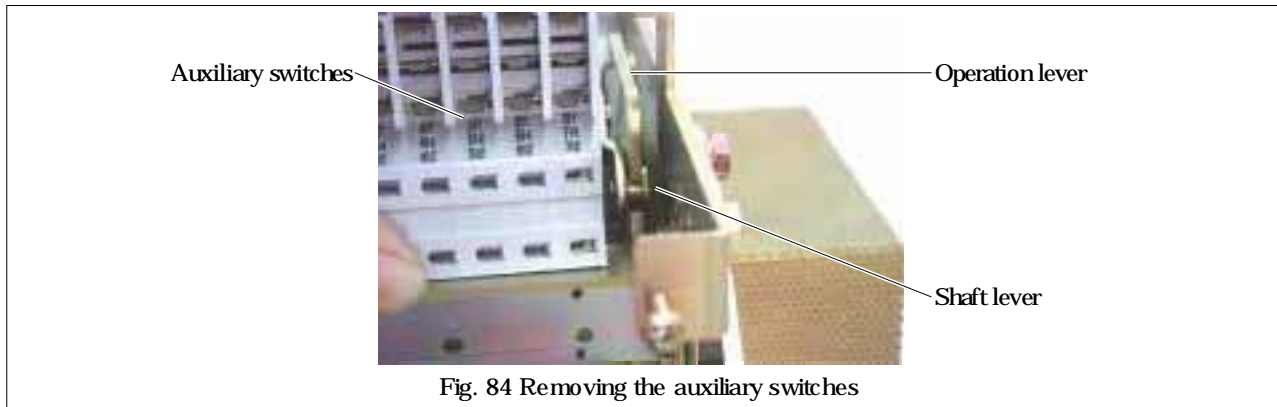

Fig. 84 Removing the auxiliary switches

6) Reinstall each part or component in reverse order of removal after inspection. When installing the auxiliary switch unit, apply molybdenum grease to the engagement of the operation lever and the shaft lever:

● Auxiliary contacts can be checked visually through the inspection holes shown in Fig. 85.



Fig. 85 Checking auxiliary contacts

7. TROUBLESHOOTING FLOWCHARTS

Figs. 86 - 90 are troubleshooting flowcharts where typical troubles and remedial actions are shown.

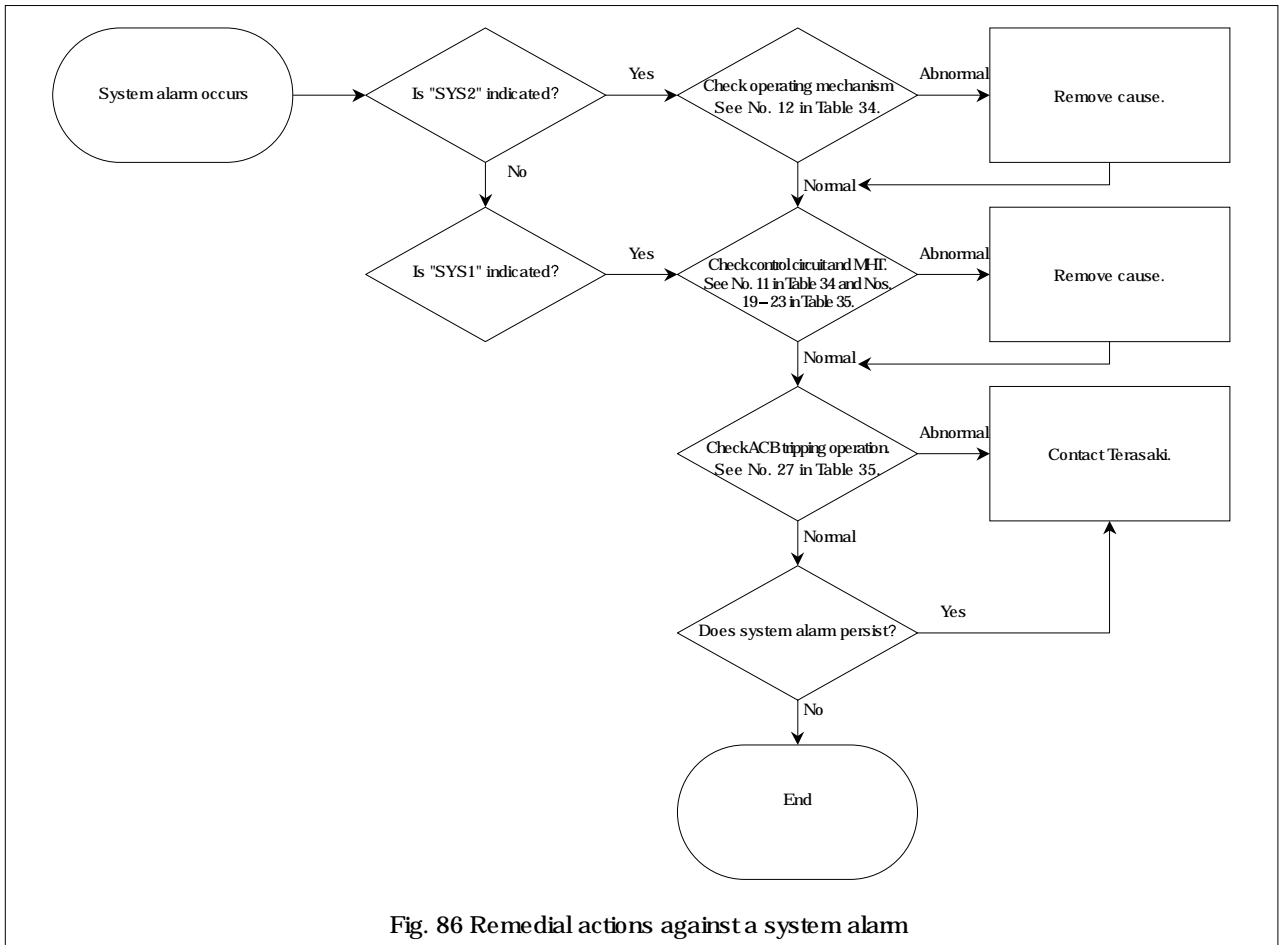

Fig. 86 Remedial actions against a system alarm

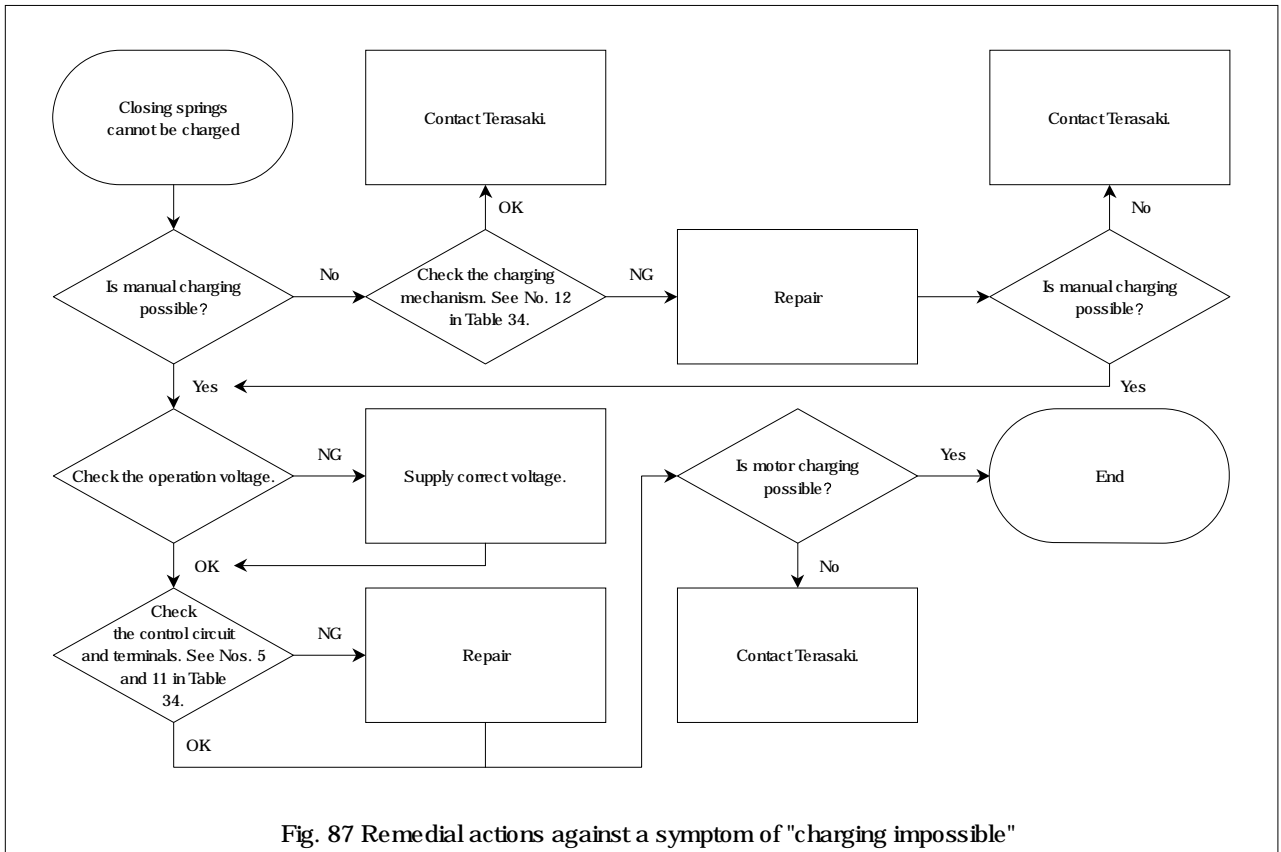

Fig. 87 Remedial actions against a symptom of "charging impossible"

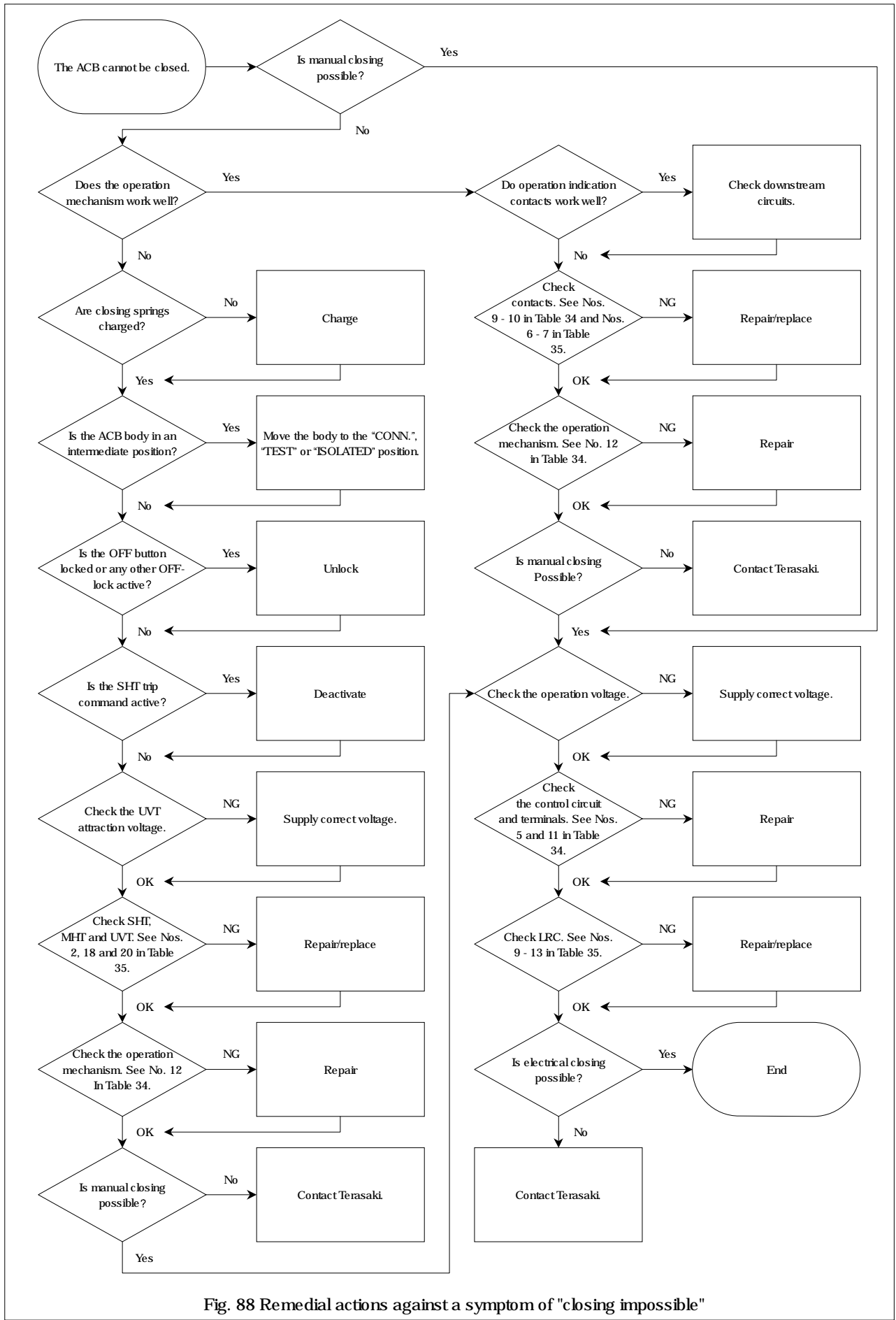

Fig. 88 Remedial actions against a symptom of "closing impossible"

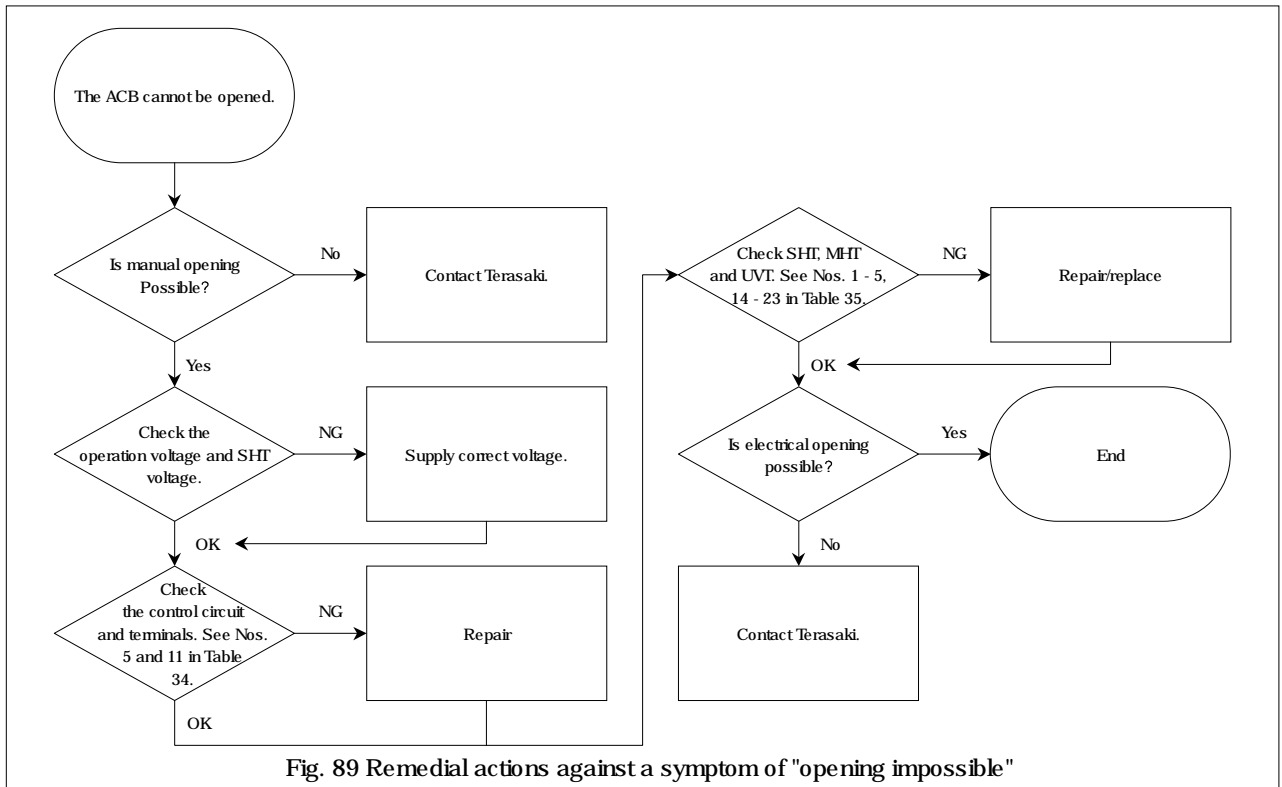

Fig. 89 Remedial actions against a symptom of "opening impossible"



Fig. 90 Remedial actions against an overheat

TERASAKI ELECTRIC CO., LTD.

Circuit Breaker Division

7-2-10 Kamihigashi, Hiranoku, Osaka 547-0002, Japan

Tel: 81-6-6791-9323

Fax: 81-6-6791-9274

Web Site: www.terasaki.co.jp E-mail: kiki-info@terasaki.co.jp

Published in May 2006

The contents of this manual may be subject to change without notice.

Recycle paper used.