

Indian Maritime University
(A Central University, Govt of India)
Supplementary Examinations – March/April 2025
Programme Name: B Tech (ME)
Semester: IV
Subject Code: UG11T3402
Subject Name: DIGITAL ELECTRONICS AND PLC

Date: 05.04.2025

Max Marks: 70

Duration: 03 Hrs

Pass Marks: 35

General Instructions

- (i) All Sections (A, B & C) are to be attempted.
- (ii) Options, if any, are specified in respective section.

Section A

Ten MCQs/Fill in the Blanks of 01 Mark each – Choose the correct answer as applicable.

1. The output of the given logic circuit is

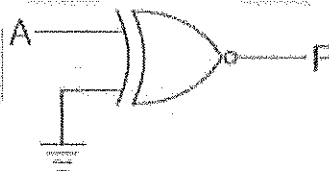

- A) 0
- B) 1
- C) A
- D) A'

2. In _____ logic circuit, the output depends only on present input?

- A) Combinational
- B) Sequential
- C) Both a and b
- D) None of the above

3. How many select lines are required in one to four de-multiplexers?

- A) 1
- B) 2
- C) 3

D) 4

4. Which of the following type of ADC is also known as continuous conversion type ADC

- A) Dual slope ADC
- B) Counter type ADC
- C) Tracking type ADC
- D) Successive Approximation ADC

5. The Boolean representation of this PLC program is

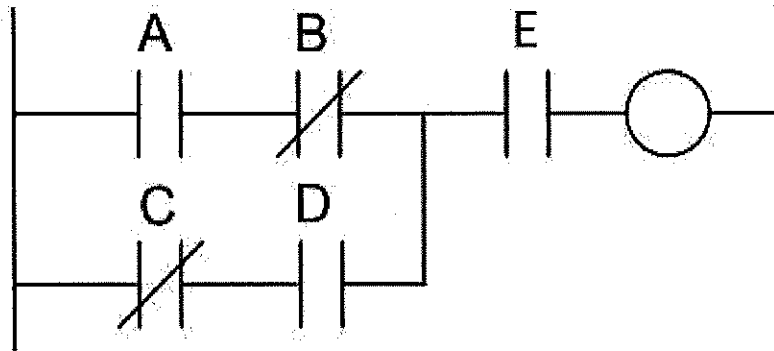

- A) $(AB'+C'D)+E$
- B) $((A+B')(C'+D))E$
- C) $(AB'+C'D)E$
- D) $((A+B')(C'+D))+E$

6. CRO cannot be used to measure?

- A) Frequency
- B) Phase
- C) Power
- D) Voltage

7. Q-meter works on the principle of

- A) Mutual Inductance
- B) Self Inductance
- C) Series Resonance
- D) Parallel resonance

8. How many useful flip-flops are there in a flag register of 8085 microprocessor?

- A) 4
- B) 5
- C) 7
- D) 10

9. If accumulator content is 88H, after execution of CMA accumulator content will be _____

- A) 77H

- B) 93H
- C) FFH
- D) 80H

10. In CMOS logic circuit the p-MOS transistor acts as:

- A) Pull down network
- B) Pull up network
- C) Load
- D) Short to ground

Section B

Five Questions of 02 Marks each

- 11. How to convert a JK Flip Flop to T Flip flop, write truth table of T flip flop.
- 12. Draw the SR Latch using NOR Gates with its function table and explain what is the forbidden state.
- 13. How PLC s are advantageous over hard wired relays?
- 14. Write a note on is RTO used in LD programming
- 15. What happens after the execution of DCR M?

Section C

Seven Questions of 10 Marks each of which any 05 questions to be answered.

16.(a) Simplify the following Boolean function

$$f(A,B,C,D) = \Sigma (0,1,3,4,8,9,11,13,15).$$

(b) Demonstrate how a JK Flip Flop can be made from a SR latch.

[5+5]

17.(a) Brief the operation of a CMOS - NOT gate.

(b) Discuss the operation of a Half-adder with circuit diagram and truth table.

[5+5]

18.(a) Explain the basic components of PLC with necessary block diagram.

(b) Draw ladder diagram for the logic given below:

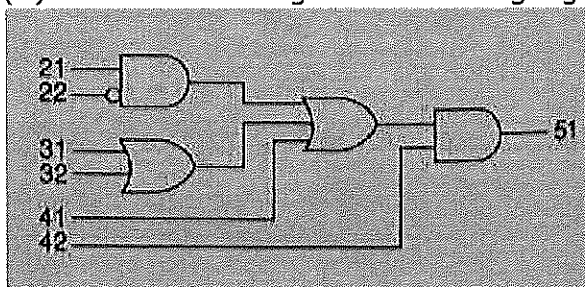

[5+5]

19. Draw the SCADA architecture and explain the different levels involved in a control and monitoring process. [10]
20. Draw the architecture of 8085 microprocessor and explain. [10]
21. (a) Write a ALP program to add two numbers 8 bit numbers 30H and 43H stored at 4050 and 4051, store the results at 4052 and 4053H.
- (b) Write a note on hardware interrupts in 8085 microprocessors. [5+5]
22. (a) Explain the operation of a Digital Frequency meter.
- (b) Write a note on Weighted resistor Digital to Analog converter. [5+5]

T M M