

Indian Maritime University
(A Central University, Govt of India)
End Semester Examinations – June 2024
Programme Name: B Tech (ME)
Semester: II
Subject Code: UG11T4202
Subject Name: Basic Electrical Engineering

Date: 29.05.2024

Max Marks: 70

Duration: 03 Hrs

Pass Marks: 35

General Instructions

- (i) All Sections (A, B & C) are to be attempted.
- (ii) Options, if any, are specified in respective section.

Section A

Ten MCQs/Fill in the Blanks of 01 Mark each – Choose the correct answer as applicable.

1. One Joule is equal to _____.
 - a. 1 Watt-sec
 - b. 1 Watt-hr
 - c. 1 kWhr
 - d. 1 kW-sec
2. Which of the following is expressed in Joules/coulomb?
 - a. Electric Current
 - b. Electric Potential
 - c. Resistance
 - d. Specific Resistance
3. Ohm's law applies to which of the materials listed below?
 - a. Silicon
 - b. Carbon
 - c. Platinum
 - d. Gallium arsenide
4. An electric heater of rating 750 W is used for 2 hours per day for 20 days. What is the electrical energy utilized?
 - a. 120 kWh
 - b. 100 kWh
 - c. 60 kWh
 - d. 30 kWh
5. The equation of an alternating voltage is given by $v = 200 \sin 314 t$. The RMS value of the voltage is _____ Volts.
 - a. 200
 - b. 141.42
 - c. 180.18
 - d. 222
6. The power-factor of a pure inductive circuit will be _____.
 - a. unity
 - b. zero leading
 - c. zero lagging
 - d. 0.866 lagging

7. Out of the following, which one is not a source of electrical energy?
(a) Solar cell (b) Battery (c) Potentiometer (d) Generator
8. The total number of magnetic field lines passing through an area is termed as?
(a) Voltage (b) EMF (c) Magnetic flux density (d) Magnetic flux
9. In any A.C. circuit always:
(a) Apparent power is more than actual power
(b) Reactive power is more than apparent power
(c) Actual power is more than reactive power
(d) Reactive power is more than actual power
10. Power factor of an electrical circuit is equal to:
(a) Cosine of phase angle difference between current and voltage
(b) Ratio of useful current to total current
(c) R/Z
(d) All above

Section B

Five Questions of 02 Marks each

11. Define supernode and supermesh.
12. What is form factor and peak factor?
13. Give the statement for Faraday's law of electromagnetic induction.
14. Calculate the reactive power for the given circuit.

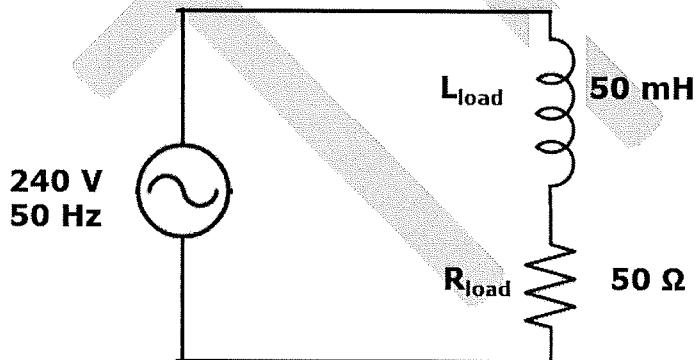

15. A generator supplies power to a factory through cables of total resistance 20 ohms. The potential difference at the generator is 5kV and power output is 50kW. Find the power supply at the factory.

Section C

Seven Questions of 10 Marks each of which any 05 questions to be answered.

16. (a) Determine the value of 'R' in ohms for the circuit depicted so that no current flows through the 30 V battery. (6 marks)

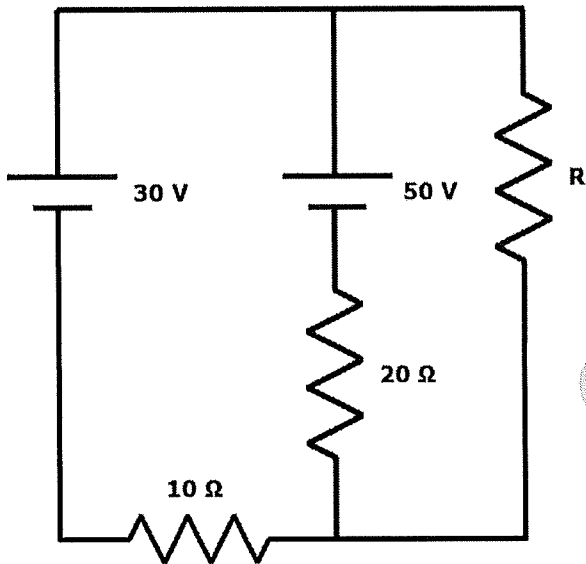

- (b) Find the equivalent resistance of the resistance arrangement illustrated in the figure between points A and B. (4 marks)

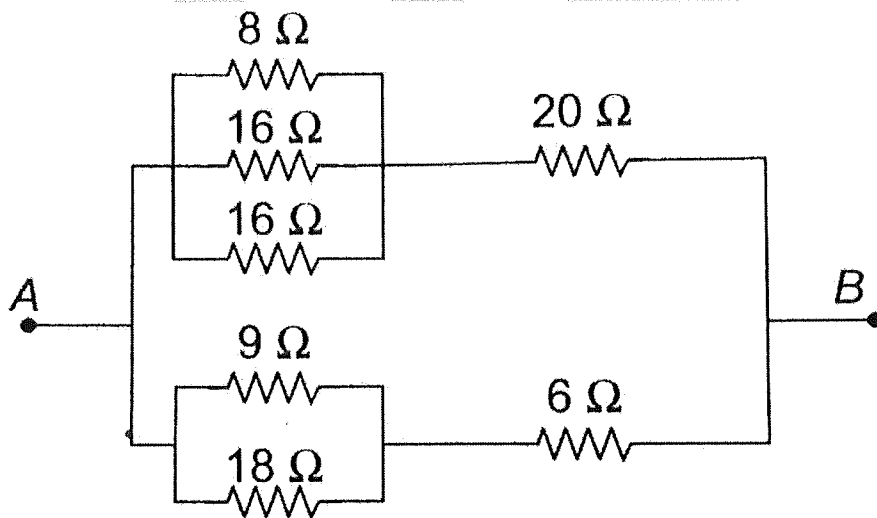

17. Using mesh current analysis method, find the current through all the resistances of the given circuit. (10 Marks)

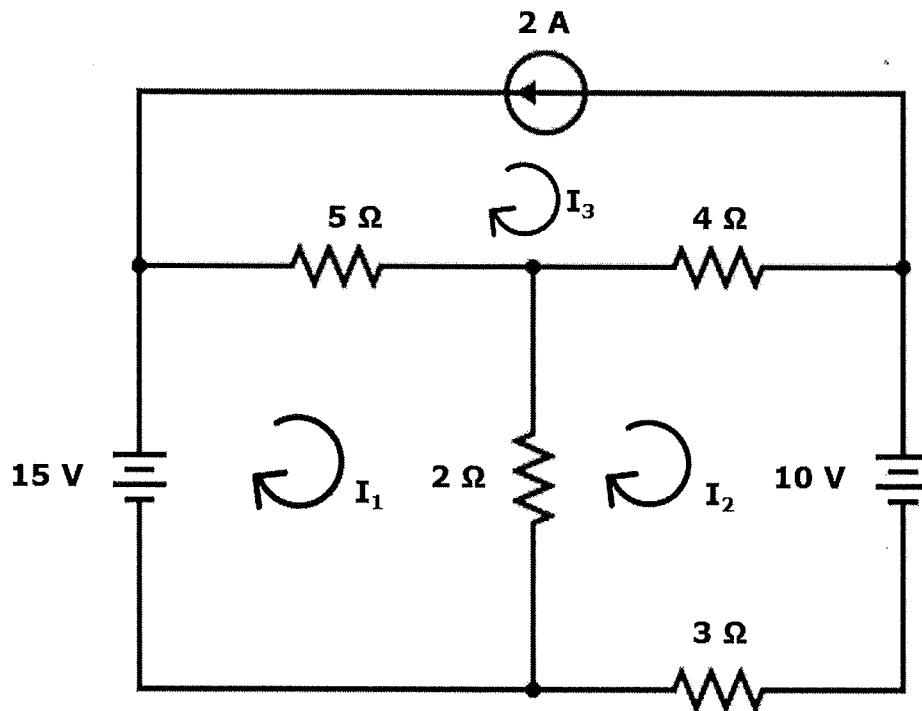

18. The current $i(t)$ in a pure resistor of $10\ \Omega$ is shown in the figure. Find the power dissipated in the resistor. Also find the peak factor for the given waveform. (10 Marks)

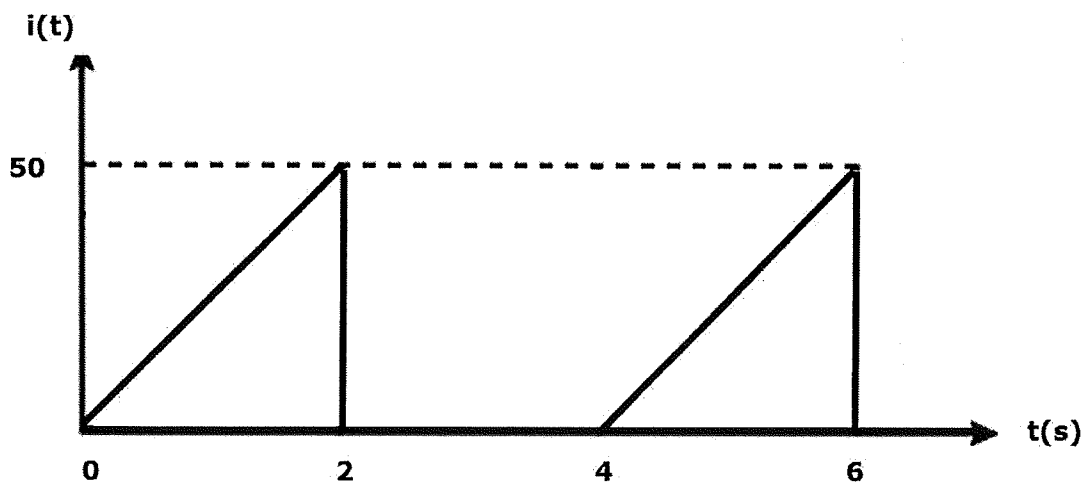

19. (a) A voltage of ' $100 \sin \omega t$ ' is applied to a $10\ \Omega$ resistor. Find the current and average power. (4 Marks)

(b) Two coils A and B lie in parallel planes. Coil A has 10,000 turns and coil B has 7,000 turns. 60% of flux produce by coil A, links Coil B. A current of 10 A in coil A produces 0.03 mWb, while the same current in coil B produces 0.06 mWb. Calculate the mutual inductance and the coupling coefficient. (6 Marks)

20 (a) The coefficient of coupling between two coils is 0.85. Coil-1 has 250 turns. When the current in coil-1 is 2A, the total flux of this coil is 3×10^{-4} Wb. When I_1 is changed from 2A to zero linearly in 2ms, the voltage induced in the coil -2 is 63.75V. Find L_1 , L_2 , M and N_2 . (5 marks)

(b) Define Average value, RMS value and calculate RMS value of a sinusoidal current (1+1+3 = 5 marks)

21. Using a neat diagram, describe how a basic loop generator may be utilised to produce a single phase AC waveform. (10 Marks)

22. Explain the construction and operation of an insulation tester or megger. (10 marks)

