

R

INDIAN MARITIME UNIVERSITY
(A Central University, Government of India)
End Semester Examinations December 2018
Semester -I
B. Tech (Marine Engineering)
Engineering Mechanics – I (UG11T3105)

Date: 07-01-2019
Time: 3Hrs

Maximum Marks: 100
Pass Marks: 50

PART A

Question – 1 is compulsory (10 X 3 = 30 Marks)

Q.1.

- a. List and explain equations of equilibrium for following force systems - coplanar concurrent, coplanar general and concurrent forces in space.
- b. What is principle of virtual work? When is virtual work negative?
- c. What do you understand by machine law? What is the use?
- d. State and explain parallel axis theorem for moment of inertia.
- e. Explain why first moment of area can be positive or negative but second moment of area will always be positive.
- f. Define centroid and centre of gravity. Distinguish between them.
- g. List the assumptions made for solving a truss.
- h. Define range of projectile and condition for maximum range.
- i. Differentiate between fixed axis rotation and general plane motion.
- j. The motion of a particle moving in a straight line is given by expression $s = t^3 - 3t^2 + 2t + 5$ where 's' is displacement in metres and 't' is time in seconds. Find the velocity and acceleration after 4 s.

PART B

Note: Answer any 5 questions from question no. 2 to 8.

(Total 5 X 14 = 70 Marks)

- Q.2.(a) In a lifting machine, an effort of 310N raised a load of 10000N load. What is the mechanical advantage? If the efficiency of machine is 75%, what is the velocity ratio? If on this machine an effort of 610N raised a load of 20000N, what is the new efficiency of machine at this load? What will be the effort required to raise a load of 5000N load? What is the maximum mechanical advantage and maximum efficiency? (7 Marks)

- (b) Determine the reaction at supports A and B in the simply supported beam AB 4m long by virtual work principle. $AC = CB = 2m$. The beam has UDL of $10kN/m$ over AC. (7 Marks)

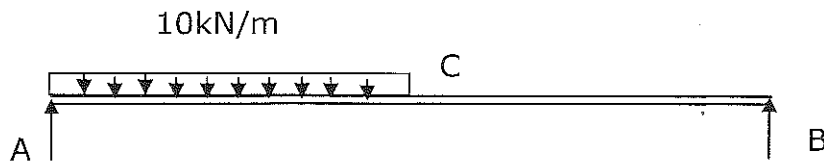

- Q.3. Determine the axial forces in the members of the truss shown. $AB=BC=CD=DE=3m$, $CG=3m$ (14 Marks)

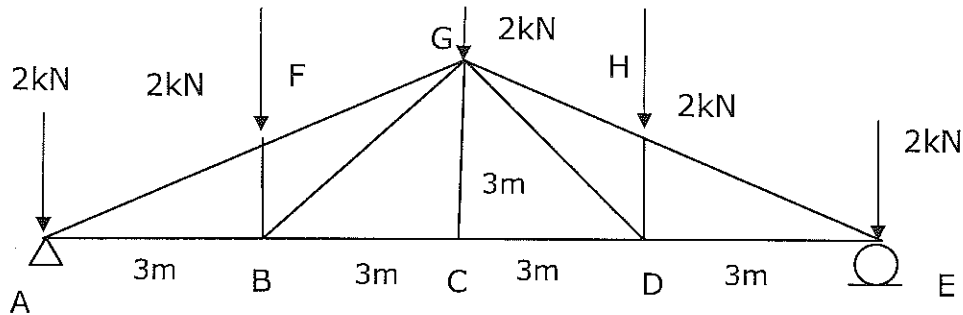

- Q.4. Determine the centroid of the composite section shown in the figure. The base of rectangle is $8cm$, height of rectangle is $3cm$ and height of triangle is $3cm$. A circular section of $2cm$ diameter has been removed from the composite area. Coordinates of centre of circular section are $(4,3)$ from bottom left of figure. (14 marks)

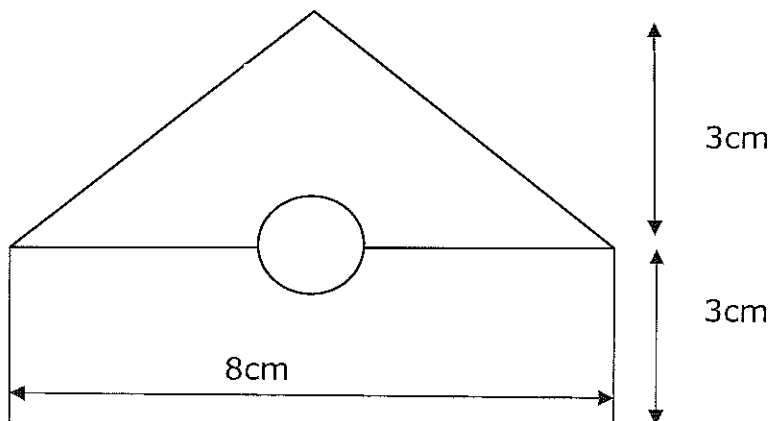

Q.5. Find the moment of inertia of I section as shown about centroidal axes of the section. The thickness of web and flange is 2 cm. (14 Marks)

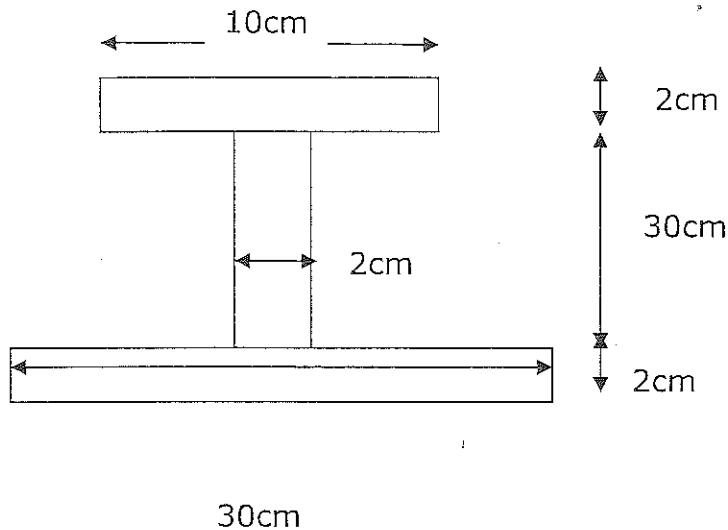

Q.6. A stuntman wants to cross the ditch of 8m width as shown. Find the minimum velocity required at point A to cross the ditch. Also find the direction and magnitude of velocity of stuntman at the instant when he reaches B on the other end. B is 4m below point A. (14 Marks)

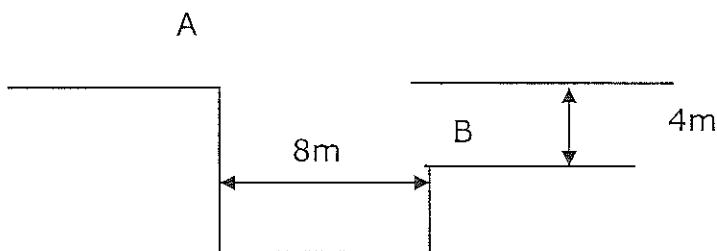

Q.7(a) Determine the tension in the string and acceleration of the blocks A and B weighing 1500N and 500N connected by an inextensible string. The pulleys may be treated as frictionless and weightless. (7 Marks)

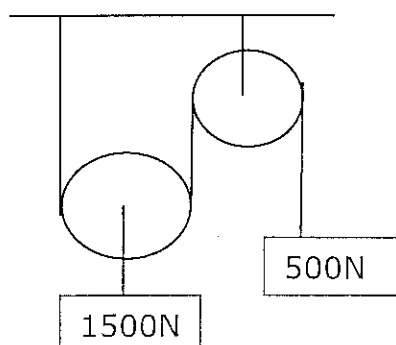

- (b) A small block starts from rest at point A and slides down the inclined plane as shown. The angle of inclination is $\theta = 45^\circ$. What velocity will it achieve when it reaches the bottom of the incline plane B. Plane AB is 5m long. Coefficient of friction may be taken as 0.3 between the block and the inclined plane. Use work energy principle for getting the velocity. (7 Marks)

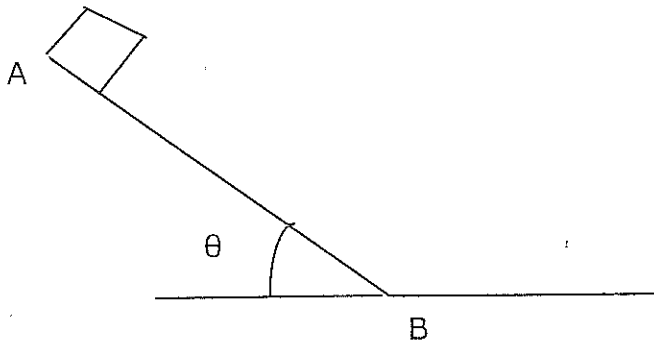

- Q.8. Two smooth cylinders A and B each of weight 445N and radius 152mm are connected at their centres by an inextensible string AB of length $l = 406\text{mm}$. They rest on a horizontal surface and support a third cylinder above them as shown. The weight of third cylinder is 890N and radius = 152mm. Find the tension in the string and reactions produced by floor at points of contacts D and E. (14 Marks)

