

**Indian Maritime University**  
 (A Central University, Govt. Of India)  
**End Semester Examination Dec-2019/Jan-2020**  
 B. Tech(Marine Engineering)  
**Semester –VII/VIII**  
**Advanced Marine Control Engineering & Automation**  
**UG11T2702/1802**

Date: 11-12-2019  
 Time: 3 Hrs

Max Marks: **70**  
 Pass Marks: **35**

**Part – A (compulsory)**  
**Answer the following (10x2=20 Marks)**

- 1) Determine the natural frequency for given system which is represented by equation,

$$3 \frac{d^2y}{dt^2} + 9 \frac{dy}{dt} + 48y = 9x, \text{ where } y \text{ is output and } x \text{ is input for the system.}$$

- 2) What is close loop transfer function (CLTF) and open loop transfer function (OLTF).  
 3) Define thermal resistance and thermal capacitance.  
 4) What is the Mason's gain formula in signal flow graph?  
 5) A unity feedback system has,  $G(s) = \frac{k}{s(s+2)(s^2+2s+5)}$

For a unit ramp input it is desired  $e_{ss} \leq 0.2$ . Find k.

- 6) Sketch a (1 to 5 V) to (4-20 mA) converter using a passive device and mention its rating. What will be the effect of (with and without) load resistance?  
 7) What will be the effect of fully opening the integral action valve in a pneumatic three term controller? What will be the effect of low hysteresis setting in an ON-OFF controller?  
 8) What is a Volume booster and why it is used?  
 9) What is meant by telemetering?  
 10) What is the importance of the third element in a boiler water level control?

**Part – B**

**Answer any 5 out of 7 questions (5 x 10= 50 marks)**

11. a) Use block diagram reduction technique to find out the overall transfer function of the system shown in figure.

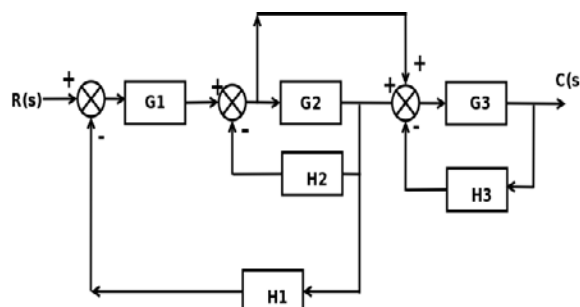

(5 marks)

- b) Consider the liquid level system as shown in the diagram. In this system 2 tanks interact. Find the transfer function  $Q_2(S)/Q(s)$ .

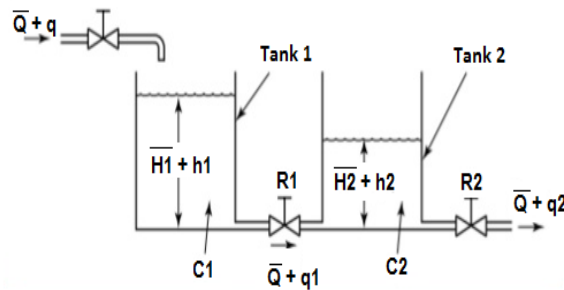

(5 marks)

12. a) Find time domain specifications (Maximum overshoot, rise time, settling time, peak time, delay time) for a control system with close loop transfer function,

$$\frac{C(s)}{R(s)} = \frac{1}{s^2 + s + 1}$$

(5 marks)

- b) Explain the working of an ON-OFF Controller with a neat labeled sketch.

(5 marks)

13. a) Explain the working of a pulse type controller with a neat sketch. (5 marks)

- b) Explain any one of the experimental tuning method of a PID controller.

(5 marks)

14. a) Why is it considered necessary to fit valve positioner in a correcting unit?

(2 marks)

- b) Sketch the various combinations of a pneumatic diaphragm actuators and valves (Highlight direct/reverse action and ATO/ATC).

(3 marks)

- c) Sketch and label the components of a valve positioner fitted on a diaphragm actuator.

(5 marks)

15. a) Explain the working of a variable capacitance differential pressure transducer with a neat labeled sketch. (7 marks)

- b) Sketch and label the components of a force balance electronic transducer. (3 marks)

16. a) Draw and explain the fuel oil viscosity control system which has a pneumatic P+I controller. (5 marks)

- b) Write down the UMS classification requirements of the following equipment. (5 marks)

- i) Fire Detection and Alarm System
- ii) Emergency Generator
- iii) Steering gear system

17. a) Draw and explain the effect of PID controller on output characteristics.

(5 marks)

- b) Draw a simple block diagram of a PLC and explain the functions of the components. (5 marks)