

**Indian Maritime University**  
**(A Central University, Govt of India)**

**Sep/Oct'25 SE**

**Programme Name: B Tech (ME)**

**Semester: III**

**Subject Code: UG11T4302**

**Subject Name: Solid Mechanics**

---

Date: 17.09.2025

Max Marks: 70

Duration: 03 Hrs

Pass Marks: 35

---

General Instructions

- (i) All Sections (A, B & C) are to be attempted.
- (ii) Options, if any, are specified in respective section.

**Section A**

Ten MCQs/Fill in the Blanks of 01 Mark each – Choose the correct answer as applicable.

1. What is tensile strain?

- a) The ratio of change in length to the original length
- b) The ratio of original length to the change in length
- c) The ratio of tensile force to the change in length
- d) The ratio of change in length to the tensile force applied

2. Find the elongation of an steel rod of 100mm length when it is subjected to a tensile strain of 0.005?

- a) 0.2mm
- b) 0.3mm
- c) 0.5mm
- d) 0.1mm

3. Modulus of resilience is defined as \_\_\_\_\_

- a) Resilience at ultimate stress
- b) Resilience per unit volume
- c) Resilience at proportional limit
- d) Resilience at elastic limit

4. Angle of twist of a circular shaft under the action of a torsional moment 'T' is given by.....

- a)  $GJ/TL$
- b)  $TJ/TL$

- c) TL/GJ
- d) TG/TL

5. Torque is \_\_\_\_\_ moment.

- a) Twisting
- b) Shear
- c) Bending
- d) Couple

6. If the thickness of plate is negligible when compared to the diameter of the cylindrical, then it is called \_\_\_\_\_

- a) Thick cylinder
- b) Thin cylinder
- c) Hoop cylinder
- d) Circumferential cylinder

7. Oil tanks, steam boilers, gas pipes are examples of \_\_\_\_\_

- a) Thick shells
- b) Thin cylinders
- c) Hoop cylinders
- d) Longitudinal cylinders

8. \_\_\_\_\_ is as the maximum energy that can be absorbed within the proportionality limit.

- a) Proof resilience
- b) Modulus of resilience
- c) Impact resilience
- d) Resilience

9. A ratio of the uniform pressure intensity to volumetric strain is called

- a) Shear Modulus
- b) Poisson's Ratio
- c) Young's Modulus
- d) Bulk Modulus

10. In thin cylindrical pressure vessel, hoop stress is \_\_\_\_\_ the longitudinal stress

- a) Twice
- b) Thrice
- c) One half
- d) Equals to

### **Section B**

Five Questions of 02 Marks each

11. Define stress.

12. What are the assumptions made in Torsion equation

13. Define the term resonance in vibration

14. What is a spring?

15. What is mean by Circumferential stress (or hoop stress) and Longitudinal stress?

### **Section C**

Seven Questions of 10 Marks each of which any 05 questions to be answered.

16. A specimen of steel 20 mm diameter with a gauge length of 200 mm is tested to destruction. It has an extension of 0.25 mm under a load of 80 kN and the load at elastic limit is 102 kN. The maximum load is 130 kN.

The total extension at fracture is 56 mm and diameter at neck is 15 mm. Find

- (i) The stress at elastic limit.                      2marks
- (ii) Young's modulus.                                      2marks
- (iii) Percentage elongation.                              2marks
- (iv) Percentage reduction in area.                      2marks
- (v) Ultimate tensile stress.                              2marks

17. A bar 2 meter in length is subjected to a pull such that the maximum stress is equal to  $150 \text{ N/mm}^2$ . Its area of cross section is  $200 \text{ mm}^2$  over a length of 1800 mm and for the middle 200 mm length, the sectional area is  $100 \text{ mm}^2$ . If  $E = 2 \times 10^5 \text{ N/mm}^2$ , calculate the strain energy stored in the bar?

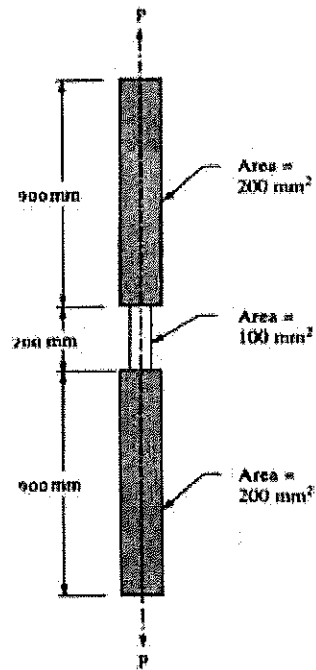

18. The state of stress at a point in a strained material is as shown in Fig. below Determine

- (i) the direction of principal planes 3 marks
- (ii) the magnitude of principal stresses and 3 marks
- (iii) the magnitude of maximum shear stress. 4 marks

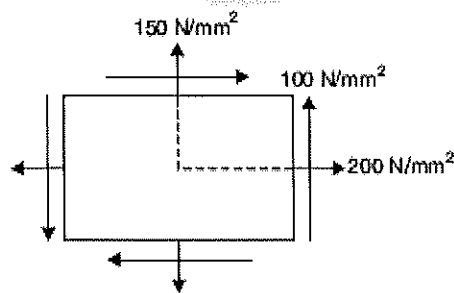

19. A helical coil spring is made of round steel wire 6 mm in diameter. The mean radius of helix is 30 mm, number of complete turns are 10; the spring is close-coiled. If  $G = 84.36 \text{ GN/m}^2$ , find

- a) pull required to extend the spring by 24 mm
- b) stress in the wire
- c) spring constant

(10 Marks)

20. Derive the Torsion equation for a shaft fixed at one end and torque being applied at the other end. - (10) Marks

21. A boiler is subjected to an internal steam pressure of  $2 \text{ N/mm}^2$ , the thickness of a boiler plate is  $2 \text{ cm}$  and permissible tensile stress is  $120 \text{ N/mm}^2$ , find out the maximum diameter when efficiency of longitudinal joint is  $90\%$  and that of circumferential joint is  $40\%$ . - (5+5) Marks

22. A  $1800 \text{ mm}$  long shaft ABCD of diameter  $60 \text{ mm}$  over half its length AB and  $40 \text{ mm}$  diameter for the remaining half-length BD, is subjected to a torque of  $900 \text{ Nm}$  at a section C midway between B and D. Determine the following:  
a. Reacting torque at the supports?  
b. Maximum shear stress in the shaft?

Take the Modulus of Rigidity  $(G) = 7 \times 10^4 \text{ N/mm}^2$

(7+3 Marks)

