

BOOSTER UNIT AMB-M-50-SS H2431

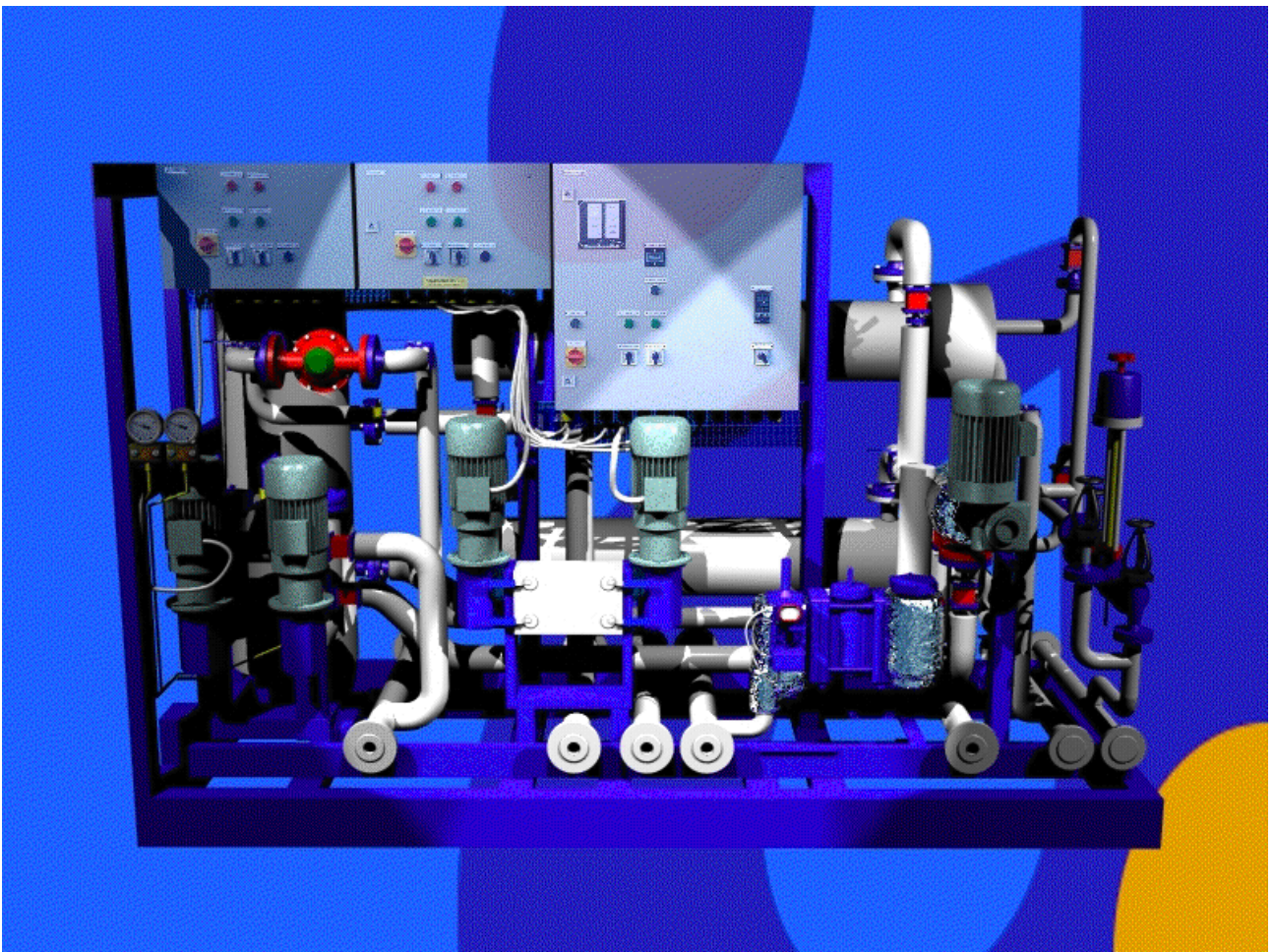

Auramarine serial number 7563

Section	Document id	Revision
1. Data sheet General arrangement	DS7563 407546	
2. P&I diagram Part list	306648A PL306648C SPARES 7563	A C
3. Electric drawings Part list	407584B PL407584B	B B
4. Factory certificate	FC7563	
6. Instruction manual	IM7563	

INDEX

- 1 Data sheet, general arrangement
- 2 P&I diagram, part list
- 3 Electric drawings, part list
- 4 Factory certificate
- 6 Instruction manual

SECTION 1

1 Data sheet, General arrangement

Heavy Fuel Oil Feeder Booster Unit Technical Specification

Type: Feeder Booster AMB-M-50-SS
Manuf. No.: 7563, 7565, 7567, 9344, 9346
Manufacturer: Auramarine Ltd
Site: Shanghai Jiangnan Changxing Heavy Ind. Co., Ltd.
5100 TEU Container vessel
H2431/-32/-33, H1025A, H1026A

1. Design Basis

Engine type : MAN 8K98MC MARK6
Total power max.: 45 760 kW
HFO viscosity max.: 600 cSt / 50 °C
Max. density: 1010 kg/m³ at 15°C
Main voltage: 440 V / 60 Hz
Control voltage: 230 VAC
Fuel consumption max.: 8.67 m³/h
Viscosity set point min.: 12 cSt
Injection temperature max.: 150 °C
Working / test pressure: 10 / 15 bar
HFO day tank temp.: 80 °C
Pressurized air: 5-10 bar

2. Technical data

Feeder pump capacity 13.3 m³/h, 4 bar, 75 cSt
Electric motor 8.6 kW, 3480 r/min
Working temp. 100°C
Motor output calculating by 700cst

Booster pump capacity 25.0 m³/h, 4/10 bar, 25.8cSt
Electric motor 12.7 kW, 3520 r/min
Working temp. 150°C
Motor output calculating by 700cst

Preheaters 2*100 % steam heaters of tube type
Over 15% fouling margin.
Max. power 397 kW, based on steam temperature /
pressure 164°C/7 bar. Steam consumption 717 kg/h.

Certificate GL

AURAMARINE LTD

Street address:
Kukkosenapaja 1
FIN-20660 LITTOINEN
FINLAND
Internet: www.auramarine.fi

Postal address:
P.O.BOX 849
FIN-20101 TURKU
FINLAND

Tel + 358 204 86 5030
Fax + 358 204 86 5031
Telex 62595 AUMA FI

Reg. office: Lieto
Trade reg. no: 402.012
ALV rek/ VAT reg: FI06846963

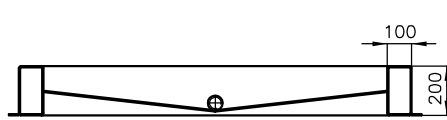
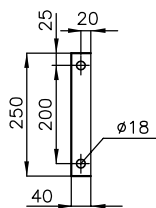
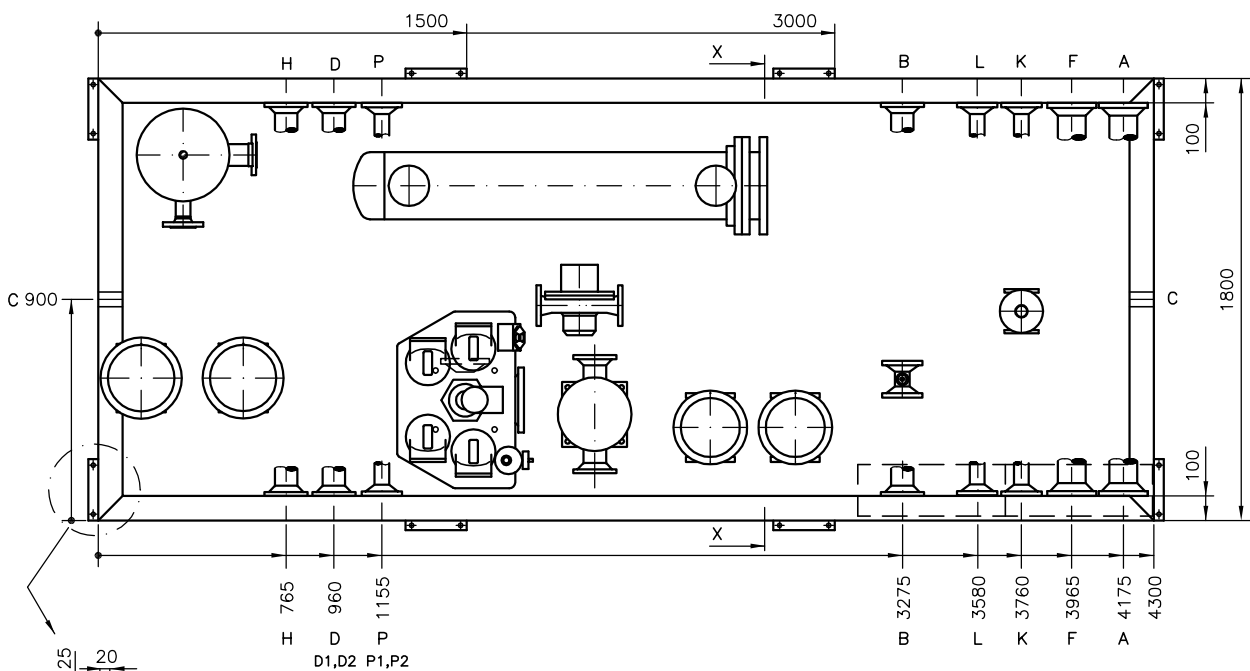
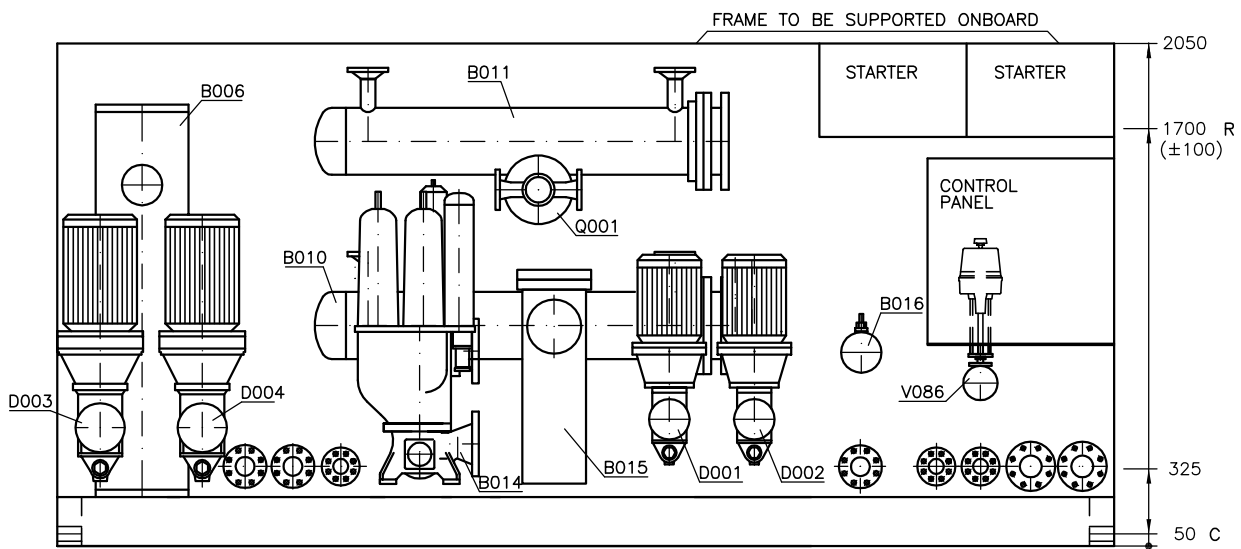

FASTENING OF THE FRAME BY WELDING ONTO THE FOUNDATION

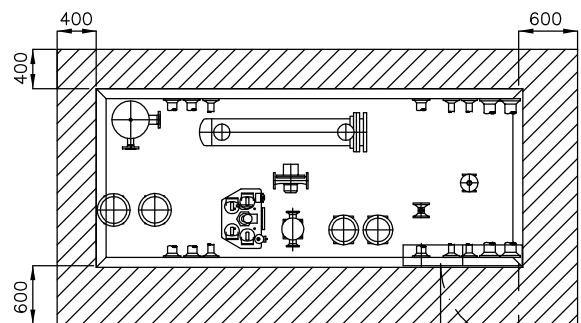

SERVICE SPACE

FOR CNTR PANEL DOOR OPENING

PIPE CONNECTION FLANGES: JIS B 2210, 16Kj

DIMENSION TOLERANCES FOR LOCATION OF PIPE CONNECTIONS ±10 mm

A	DN80	HFO INLET
B	DN65	FUEL OIL OUTLET
C	R2"	DRAIN FROM UNIT
F	DN80	MDO INLET
H	DN65	F.O. RETURN FROM ENGINE
D	DN65	DEAERATION LINE
K	DN50	STEAM INLET
L	DN50	CONDENSATE OUTLET
P	DN50	AUTOM. FILTER BACK FLUSHING LINE
R	ø10mm	INSTRUMENT AIR INLET
P1,P2	ø10mm	TRACING OF BACK FLUSHING LINE
D1,D2	ø10mm	TRACING OF DEAERATION LINE

Weight ~3700
Manuf.no 7563,7565,7567,9344,9346

REV.	DATE	MADE	APPVD.	EXPLANATION
 AURA MARINE Auramarine Ltd.				
Product		© ACA UNITS mm,kg ASLY.DRG		
MADE	29.12.2006	Tju/Julin	SCALE	Page No. DRG. No.
CHKD.	29.12.2006	TPa/Palmu	~	1/1 407546
APPD.				

FEEDER BOOSTER UNIT
AMB-M-50-SS
Shanghai Jiangnan Changxing Heavy Industry
H2431,H2432,H2433,H1025A,H1026A
GENERAL ARRANGEMENT

Rev.



SECTION 2

2 P&I Diagram, Part list

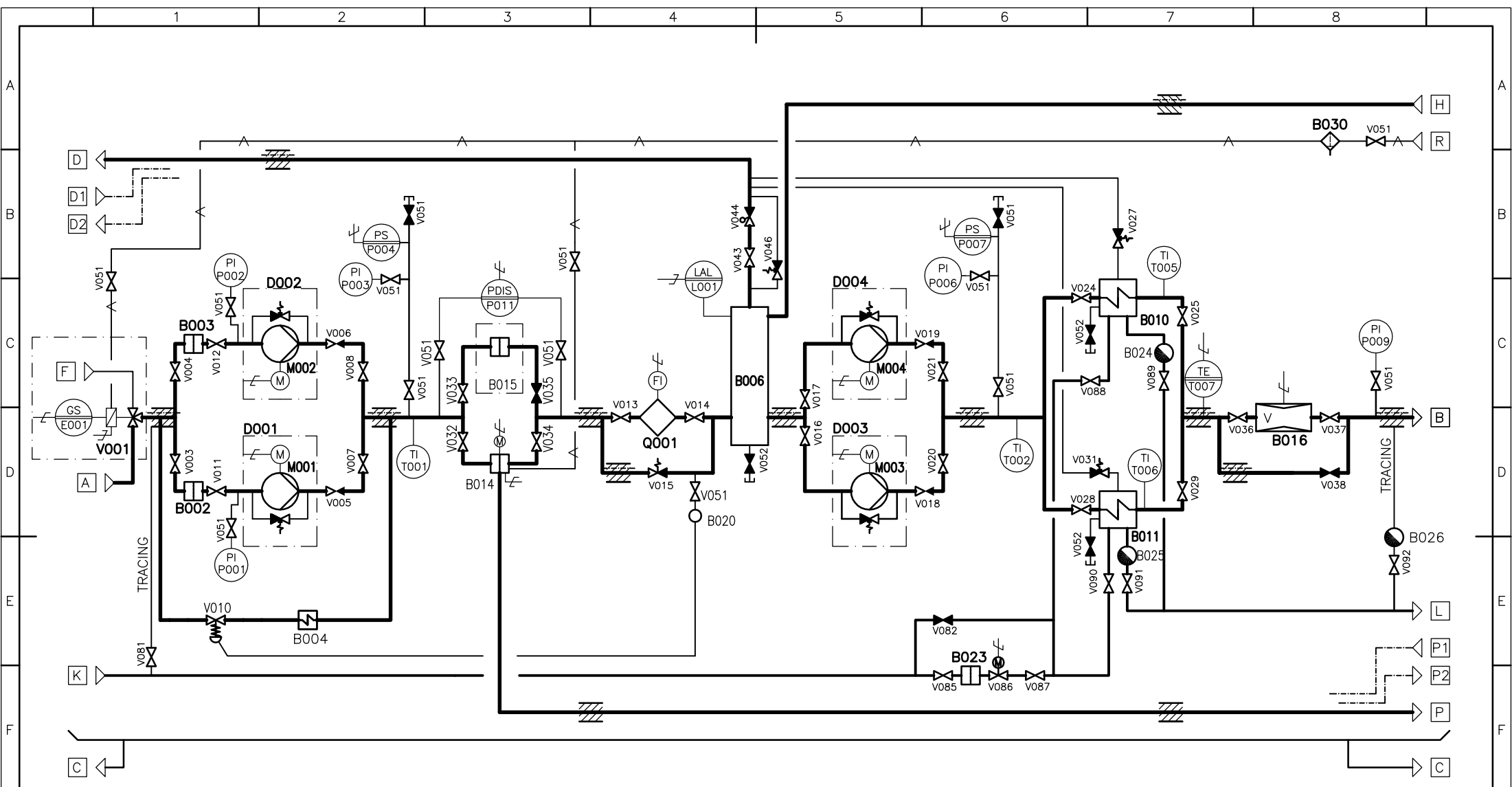

- A HFO INLET
- B FUEL OIL OUTLET
- C DRAIN FROM UNIT
- D DEAERATION LINE
- F MDO INLET
- H F.O. RETURN FROM ENGINE
- K STEAM INLET
- L CONDENSATE OUTLET
- P AUTOM. FILTER BACK FLUSHING LINE
- R INSTRUMENT AIR INLET
- D1,D2 TRACING OF DEAERATION LINE
- P1,P2 TRACING OF BACK FLUSHING LINE

TRACED AND INSULATED PIPE

A	080808	TJu	TJu	Air filter B030 added
REV.	DATE	MADE	APPVD.	EXPLANATION

AURA MARINE Auramarine Ltd.		FEEDER BOOSTER UNIT AMB-M-50-SS Shanghai Jiangnan Changxing H2431/32/33, H1025A/26A P&I DIAGRAM	
Mfg.no. 7563,7565,7567,9344,9346			
Made	28.12.2006	TJu/Julin	Asly.Drg
Chkd.	28.12.2006	TPa/Palmu	Scale
Appd.			Scale
		UNITS	mm kg
		~	Page
		1/1	DRG.No.
		306648	A
			Rev.

ITEM	QTY	PART NO	DESCRIPTION	TYPE/TECHNICAL DATA	SET RANGE	SET POINT	MANUFACTURER	MATERIAL
B002	1	AM01416	Strainer	Fig 821-GG, 400micr abs, DN 80			Econosto	EN-JL1030
B003	1	AM01416	Strainer	Fig 821-GG, 400micr abs, DN 80			Econosto	EN-JL1030
B004	1	AM00663	Cooler radiator, Rib	For tube 48mm, 83 r/m 30x1mm			Salpahitsaus	ST 35.8/I
B006	1	AM00354	Deaeration vessel	Dwg 6005-1B, 100 l, Liquiphant flan			Pumppulohja	ST 35.8/I
B010	1	AM04508	Heat exchanger	MX30-L1500-100-DN65-SAE50			Aalborg	Carbon ST
B011	1	AM04508	Heat exchanger	MX30-L1500-100-DN65-SAE50			Aalborg	Carbon ST
B014	1	AM01200	Automatic filter	6.61 GR15, 10micr abs, DN 150			Boll & Kirch	EN-JS1025
B015	1	AM04004	Filter	1.03.2.265.500, 25micr abs, DN 100			Boll & Kirch	EN-JS1025
B016	1	AM04024	Viscometer, viscosense	VS2, 0..50 cSt +PCB (In box)+Cable	0-50 cSt=4..20 mA		Vaf Instruments	1.4401
B020	1	AM02851	Pressure damper	RSB-Y G1			Econosto	
B023	1	AM01410	Strainer	Fig 821-GG, 400micr abs, DN 40			Econosto	EN-JL1030
B024	1	AM01790	Steam trap	TD 52, R1"			Spirax	1.4021
B025	1	AM01790	Steam trap	TD 52, R1"			Spirax	1.4021
B026	1	AM01787	Steam trap	TD 52 LC, R 1/2"			Spirax	1.4021
B030	1	AM04394	Air filter	F08-C2-SK00, R1/4"			Wilkerson	Aluminium
D001	1	AM04015	Feeder Pump	ACG 045K8 NJBP			IMO	EN-JS1025
D002	1	AM04015	Feeder Pump	ACG 045K8 NJBP			IMO	EN-JS1025
D003	1	AM04016	Booster Pump	ACG 052N8 NLBP			IMO	EN-JS1025
D004	1	AM04016	Booster Pump	ACG 052N8 NLBP			IMO	EN-JS1025
E001	1	AM02659	Limit switch	Automax WDB 0101201			Automatic Ventil System	Carbon ST
L001	1	AM03600	Level switch	Liquiphant FTL20-061B, R1"			Metso Endress+Hauser	1.4401
M001	1	AM04010	El. motor	WU-DA 132SJ-D-2, 8.6 kW, 3480 rpm			Brook Hansen	Aluminium
M001A	1	AM04013	Heating element for WU-DA 132	2x12W/230V, for WU-DA 132 el.motor			Brook Hansen	
M002	1	AM04010	El. motor	WU-DA 132SJ-D-2, 8.6 kW, 3480 rpm			Brook Hansen	Aluminium
M002A	1	AM04013	Heating element for WU-DA 132	2x12W/230V, for WU-DA 132 el.motor			Brook Hansen	
M003	1	AM04011	El. motor	WU-DA 160MB-D-2, 12.7 kW, 3520rpm			Brook Hansen	Aluminium
M003A	1	AM04014	Heating element for WU-DA 160	2x20W/230V, for WU-DA 160 el.motor			Brook Hansen	
M004	1	AM04011	El. motor	WU-DA 160MB-D-2, 12.7 kW, 3520rpm			Brook Hansen	Aluminium
M004A	1	AM04014	Heating element for WU-DA 160	2x20W/230V, for WU-DA 160 el.motor			Brook Hansen	
P001	1	AM00091	Pressure gauge	213.53.63.-1..+3 bar, 63x1/4"			Wika Finland	Brass
P002	1	AM00091	Pressure gauge	213.53.63.-1..+3 bar, 63x1/4"			Wika Finland	Brass
P003	1	AM00086	Pressure gauge	213.53.63. 0..16 bar, 63x1/4"			Wika Finland	Brass
P004	1	AM00186	Pressure switch	MBC 5100-2431-2CB04 1-10 bar	1..10 bar	3 bar	Danfoss	Aluminium
P006	1	AM00086	Pressure gauge	213.53.63. 0..16 bar, 63x1/4"			Wika Finland	Brass
P007	1	AM00186	Pressure switch	MBC 5100-2431-2CB04 1-10 bar	1..10 bar	8 bar	Danfoss	Aluminium
P009	1	AM00086	Pressure gauge	213.53.63. 0..16 bar, 63x1/4"			Wika Finland	Brass
P011	1	AM01257	Diff. press. switch, filter autom.	DDA 4.36.2-08	0.6/0.8 bar	0.6/0.8 bar	Boll & Kirch	Aluminium
Q001	1	AM04005	Flow meter	VZF 50 FL 130/25			Aquametro AG	GGG 42
T001	1	AM00123	Thermometer	Jako fig 42S (-), R1/2", 0-160			Jako	MS
T002	1	AM00125	Thermometer	Jako fig 43S (L), R1/2", 0-160			Jako	Brass
T005	1	AM00125	Thermometer	Jako fig 43S (L), R1/2", 0-160			Jako	Brass
T006	1	AM00125	Thermometer	Jako fig 43S (L), R1/2", 0-160			Jako	Brass
T007	1	AM04095	PT-100 sensor compact (1x)	S75-1-1-2-1, R1/2"x75	0- 200 °C	149 °C	Senmatic	1.4401
V001	1	AM03872	3-way valve 776035L (2 coil solen.)	DN80/85DA/NA54N-11-230V/WDB 0101201			Automatic Ventil System	Carbon ST
V003	1	AM02927	Shut off valve	213 SGS/BW SCH 40, DN 80			Starline Valves	Forged ST

ITEM	QTY	PART NO	DESCRIPTION	TYPE/TECHNICAL DATA	SET RANGE	SET POINT	MANUFACTURER	MATERIAL
V004	1	AM02927	Shut off valve	213 SGS/BW SCH 40, DN 80			Starline Valves	Forged ST
V005	1	AM02757	Non return valve	GB-019, DN 50			Ghibson	Sn bronze
V006	1	AM02757	Non return valve	GB-019, DN 50			Ghibson	Sn bronze
V007	1	AM02947	Shut off valve	223 SGS/BW SCH 40, DN 50			Starline Valves	Forged ST
V008	1	AM02947	Shut off valve	223 SGS/BW SCH 40, DN 50			Starline Valves	Forged ST
V010	1	AM02803	Overflow valve	RSB-Y 5610 3040 + A1 DN 40			Econosto	Cast iron
V011	1	AM02927	Shut off valve	213 SGS/BW SCH 40, DN 80			Starline Valves	Forged ST
V012	1	AM02927	Shut off valve	213 SGS/BW SCH 40, DN 80			Starline Valves	Forged ST
V013	1	AM02947	Shut off valve	223 SGS/BW SCH 40, DN 50			Starline Valves	Forged ST
V014	1	AM02947	Shut off valve	223 SGS/BW SCH 40, DN 50			Starline Valves	Forged ST
V015	1	AM02796	Overflow valve	RHD42L2 bar 42-42		2 bar	Hymat	ST 50
V016	1	AM02926	Shut off valve	213 SGS/BW SCH 40, DN 65			Starline Valves	Forged ST
V017	1	AM02926	Shut off valve	213 SGS/BW SCH 40, DN 65			Starline Valves	Forged ST
V018	1	AM02758	Non return valve	GB-019, DN 65			Ghibson	Sn bronze
V019	1	AM02758	Non return valve	GB-019, DN 65			Ghibson	Sn bronze
V020	1	AM02926	Shut off valve	213 SGS/BW SCH 40, DN 65			Starline Valves	Forged ST
V021	1	AM02926	Shut off valve	213 SGS/BW SCH 40, DN 65			Starline Valves	Forged ST
V024	1	AM02926	Shut off valve	213 SGS/BW SCH 40, DN 65			Starline Valves	Forged ST
V025	1	AM02926	Shut off valve	213 SGS/BW SCH 40, DN 65			Starline Valves	Forged ST
V027	1	AM02870	Safety valve	851 BF-16, viton, R 1/2"	1-16 bar	16 bar	Götze	Bronze
V028	1	AM02926	Shut off valve	213 SGS/BW SCH 40, DN 65			Starline Valves	Forged ST
V029	1	AM02926	Shut off valve	213 SGS/BW SCH 40, DN 65			Starline Valves	Forged ST
V031	1	AM02870	Safety valve	851 BF-16, viton, R 1/2"	1-16 bar	16 bar	Götze	Bronze
V032	1	AM02947	Shut off valve	223 SGS/BW SCH 40, DN 50			Starline Valves	Forged ST
V033	1	AM02947	Shut off valve	223 SGS/BW SCH 40, DN 50			Starline Valves	Forged ST
V034	1	AM02947	Shut off valve	223 SGS/BW SCH 40, DN 50			Starline Valves	Forged ST
V035	1	AM02947	Shut off valve	223 SGS/BW SCH 40, DN 50			Starline Valves	Forged ST
V036	1	AM02926	Shut off valve	213 SGS/BW SCH 40, DN 65			Starline Valves	Forged ST
V037	1	AM02926	Shut off valve	213 SGS/BW SCH 40, DN 65			Starline Valves	Forged ST
V038	1	AM02926	Shut off valve	213 SGS/BW SCH 40, DN 65			Starline Valves	Forged ST
V043	1	AM02975	Shut off valve	223 SGS/SC, R 1/2"			Starline Valves	Forged ST
V044	1	AM01684	Automatic air vent	Minox-G 8070, R 1/2"			Rifox	EN-JS1030
V046	1	AM02866	Safety valve	851 BF-10, viton, R 1/2"	1-10 bar	10 bar	Götze	Bronze
V051	15	AM03036	Shut off valve	RB-1720, R 1/4"			Rubinetterie Paracchini	Brass
V052	3	AM03035	Shut off valve	RB-1720, R 1/2"			Rubinetterie Paracchini	Brass
V081	1	AM02975	Shut off valve	223 SGS/SC, R 1/2"			Starline Valves	Forged ST
V082	1	AM02570	Globe valve	Fig 215-01 (-), DN 40			Econosto	EN-JL1040
V085	1	AM02592	Globe valve	Fig 216-01 (L), DN 40			Econosto	EN-JL1040
V086	1	AM03952	Motor control valve	Fig23.440, PRE2,2(230), DN40/kvs25			ARI Armaturen	EN-JS1049
V087	1	AM02570	Globe valve	Fig 215-01 (-), DN 40			Econosto	EN-JL1040
V088	1	AM02946	Shut off valve	223 SGS/BW SCH 40, DN 40			Starline Valves	Forged ST
V089	1	AM02944	Shut off valve	223 SGS/BW SCH 40, DN 25			Starline Valves	Forged ST
V090	1	AM02946	Shut off valve	223 SGS/BW SCH 40, DN 40			Starline Valves	Forged ST
V091	1	AM02944	Shut off valve	223 SGS/BW SCH 40, DN 25			Starline Valves	Forged ST
V092	1	AM02975	Shut off valve	223 SGS/SC, R 1/2"			Starline Valves	Forged ST

ITEM	QTY	PART NO	DESCRIPTION	TYPE/TECHNICAL DATA
SP01	2	AG00968	Ball bearing set for motor	WU-DA 132, spare part no. 192101
SP02	2	AG00969	Ball bearing set for motor	WU-DA 160, spare part no. 192425
SP03	1	AM00091	Pressure gauge	213.53.63.-1..+3 bar, 63x1/4"
SP04	1	AM00086	Pressure gauge	213.53.63. 0..16 bar, 63x1/4"
SP05	1	AM00123	Thermometer	Jako fig 42S (-), R½", 0-160
SP06	1	AM00125	Thermometer	Jako fig 43S (L), R½", 0-160
SP07	1	AG00970	Stainer insert	Fig 821-400 DN80
SP08	1	AF01116	Contactator	A16-30-10-80 230 V AC
SP09	1	AF01118	Contactator	A26-30-10-80 230 V AC
SP10	1	AF01112	Contactator	A9-30-10-80 230 V AC
SP11	2	AF00428	Miniature relay	40.52.8.230
SP12	2	AF00880	Indicating light	CL-523W
SP13	4	AF00882	Indicating light	CL-523R
SP14	4	AF00883	Indicating light	CL-523G

SECTION 3

3 Electric diagrams, Part list

WIDTH 600
HEIGHT 380
DEPTH 210
COLOR RAL 7035

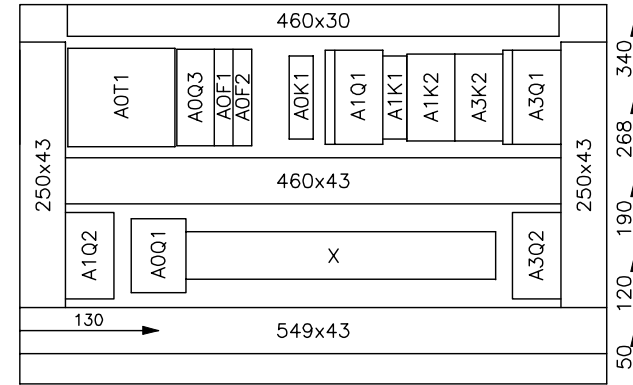
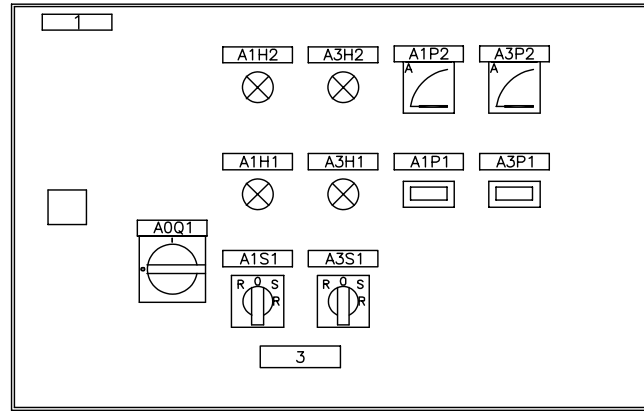

8xM20+M25
FOR SITE CABLES:
2xM20(φ5,5-12)+3xM25(φ11-18)+M32(φ17-25)

LIST OF LABELS

id	pcs	text
1	1	STARTER 1
A0Q1	1	MAIN SWITCH
A1S1	1	FEEDER PUMP D001
A3S1	1	BOOSTER PUMP D003
-H1	2	RUNNING
-H2	2	TRIPPED
A1P1	1	RUNNING HOURS OF FEEDER PUMP D001
A3P1	1	RUNNING HOURS OF BOOSTER PUMP D003
3	1	WARNING ELECTRIC MOTORS WILL START AUTOMATICALLY AFTER POWER FAILURE
A1P2	1	CURRENT OF PUMP D001 MOTOR
A3P2	1	CURRENT OF PUMP D003 MOTOR

AC 440V 60Hz



AURAMARINE Ltd
FINLAND

Product AMB-M
MADE 30.01.2007
CHKD. 30.01.2007
APPVD. 30.01.2007

CAD SCALE
KTa/Tammi
KTa/Tammi
RTu/Tuominen

HUA HAI EQUIPMENT & ENG.
JNSY H2431/32/33
M/E

BOOSTER UNIT STARTER 1
Assembly Drawing

OBJECT	=E1DDC	Pg. Cnt.	number
Lang	GB	Suppl. Ident.	7563 5 7
PROJECT #	A3-DRAWING #	SHEET	1 OF SHEETS 31
	407584	REV.	B

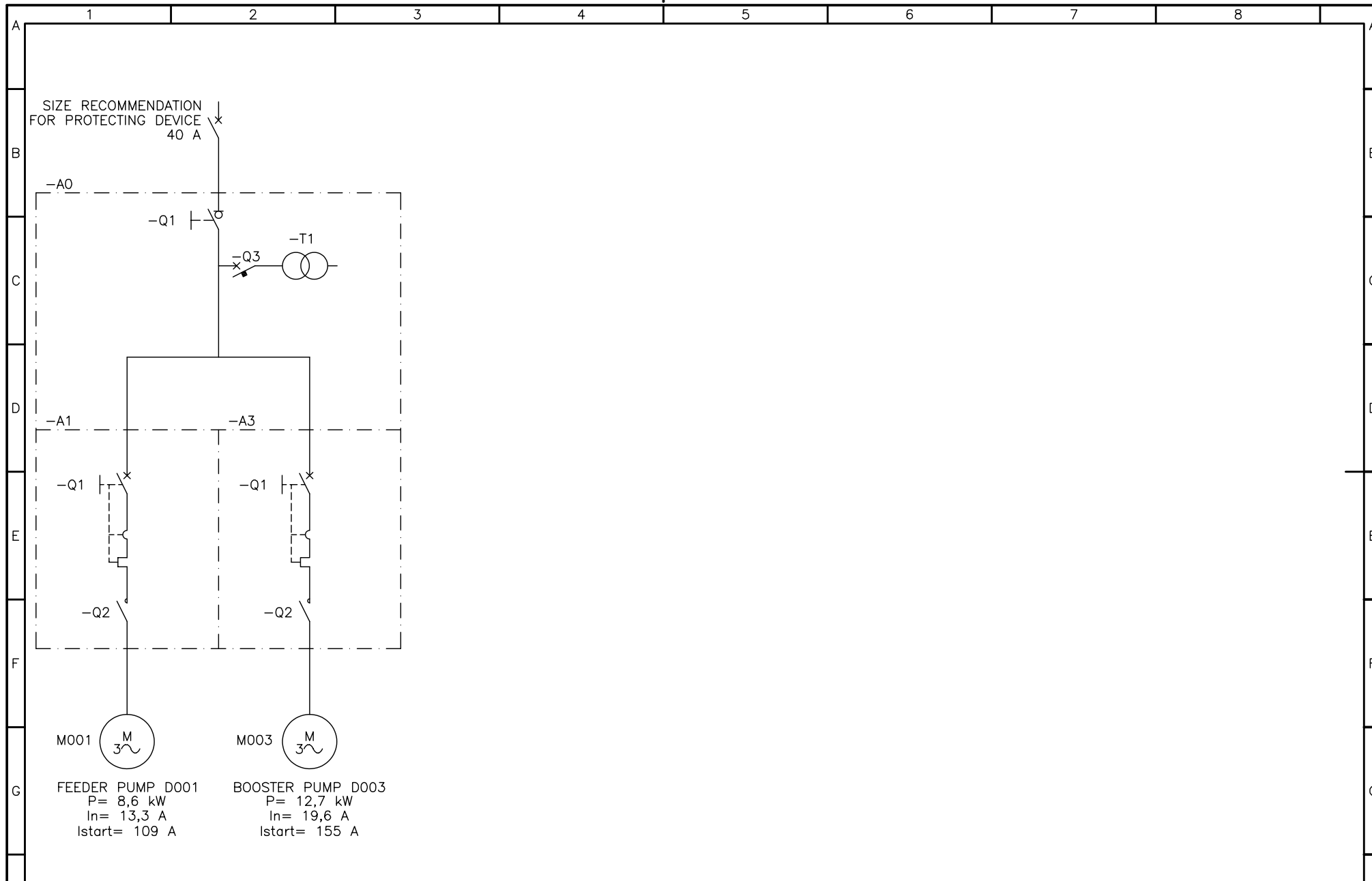

AURAMARINE Ltd
FINLAND

Product	AMB-M	CAD	SCALE
MADE	30.01.2007	KTa/Tammi	
CHKD.	30.01.2007	KTa/Tammi	
APPVD.	30.01.2007	RTu/Tuominen	

HUA HAI EQUIPMENT & ENG.
JNSY H2431/32/33
M/E

BOOSTER UNIT STARTER 1
POWER DISTRIBUTION
Single Line Diagram

OBJECT	=E1DDC	Pg. Cnt.	number
LnG	GB	Suppl. Ident.	7563 5 7
PROJECT #		A3-DRAWING #	407584
		SHEET	2
		OF SHEETS	31
		REV.	B

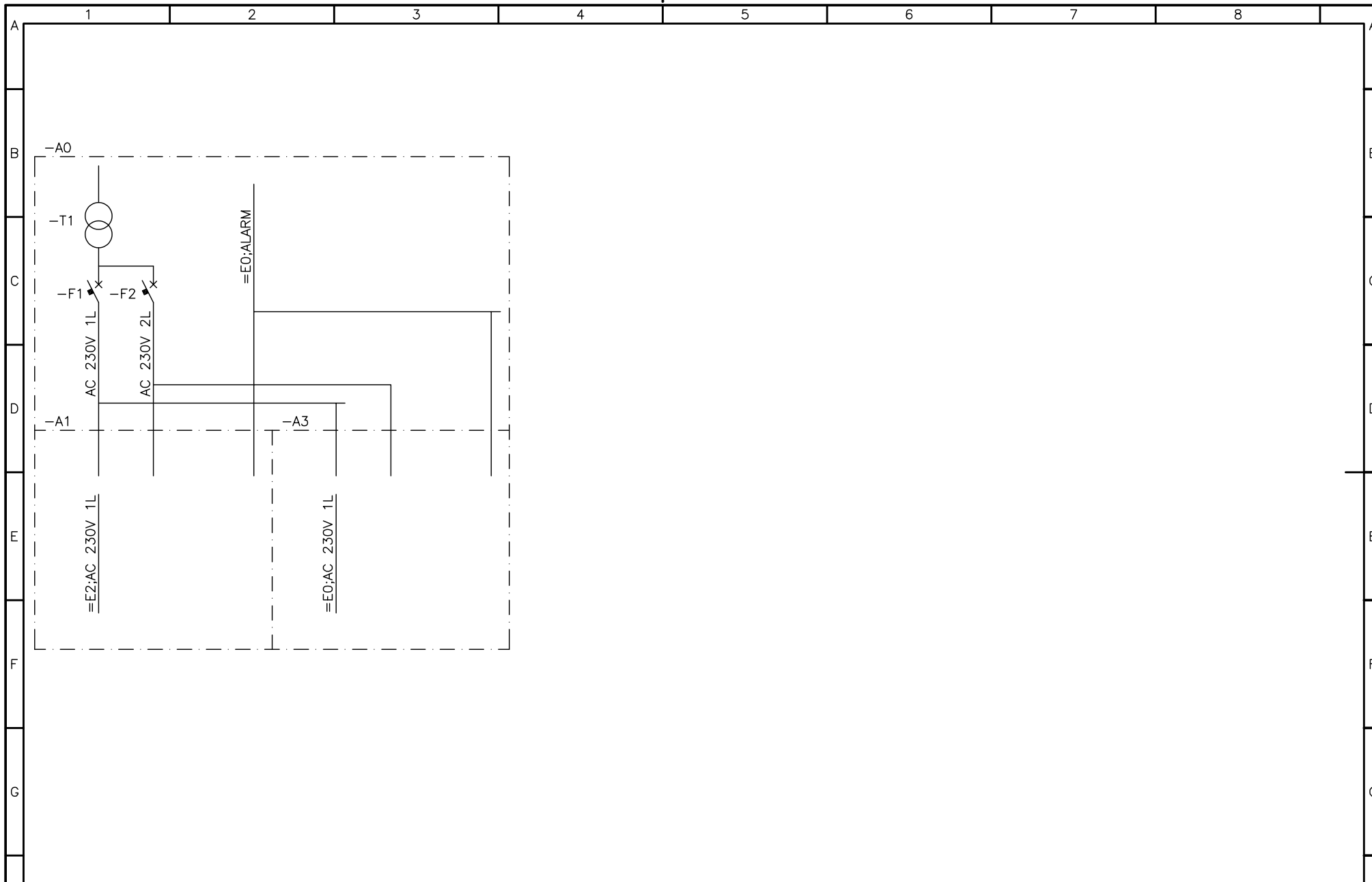

AURAMARINE Ltd
FINLAND

Product	AMB-M	CAD	SCALE
MADE	30.01.2007	KTa/Tammi	
CHKD.	30.01.2007	KTa/Tammi	
APPVD.	30.01.2007	RTu/Tuominen	

HUA HAI EQUIPMENT & ENG.
JNSY H2431/32/33
M/E

BOOSTER UNIT STARTER 1
CONTROL VOLTAGE DISTRIBUTION
Single Line Diagram

OBJECT	=E1 DDC	Pg. Cnt.	number
Lang	GB	Suppl. Ident.	7563 5 7
PROJECT #	-	A3-DRAWING #	407584
		SHEET	3
		OF SHEETS	31
		REV.	B

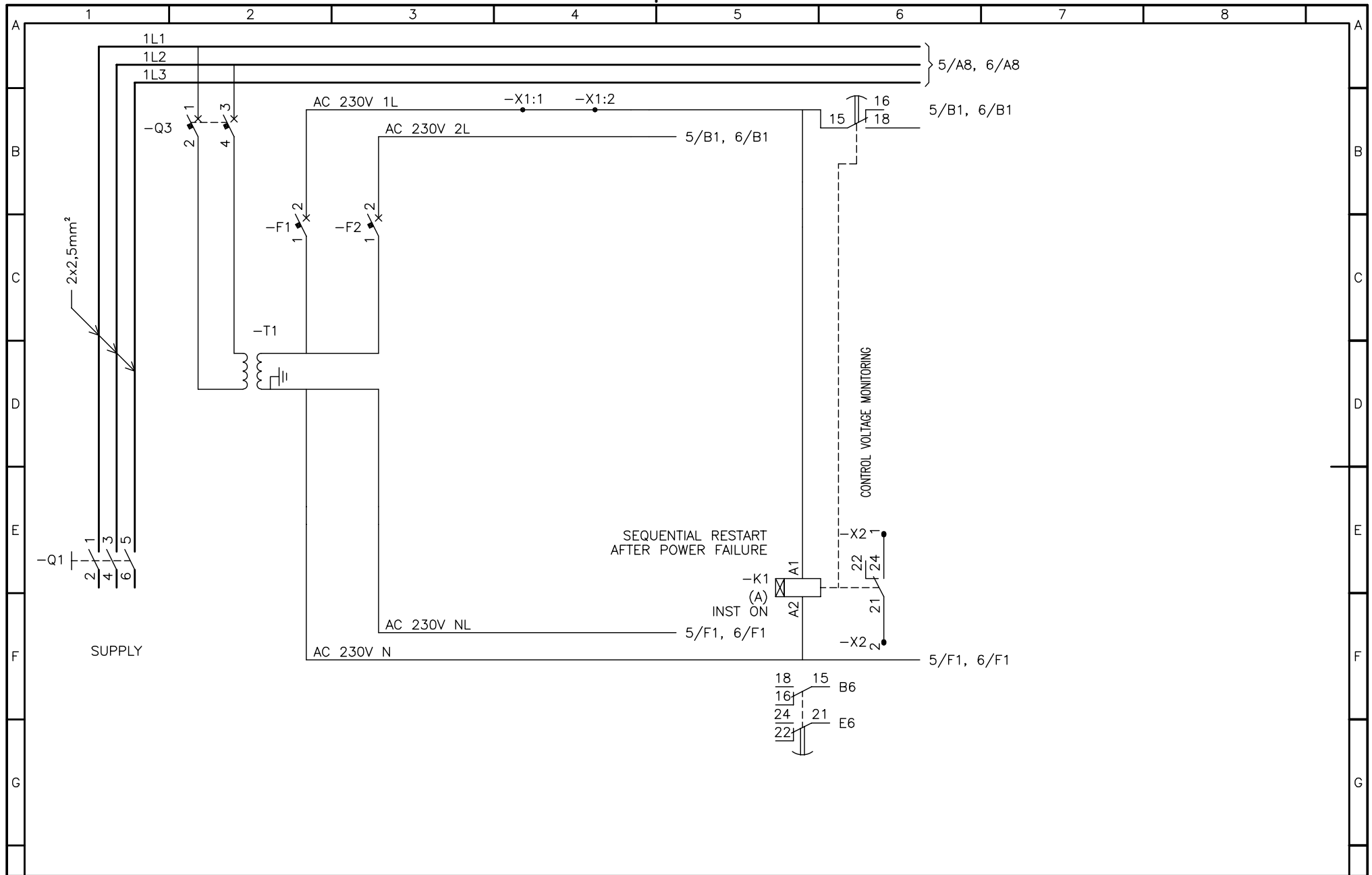

Product	AMB-M	SCALE	1:1
MADE	30.01.2007	KTa/Tammi	
CHKD.	30.01.2007	KTa/Tammi	
APPVD.	30.01.2007	RTu/Tuominen	

HUA HAI EQUIPMENT & ENG.
JNSY H2431/32/33
M/E

BOOSTER UNIT STARTER 1
SUPPLY
Circuit Diagram

OBJECT	=E1-A0	DDC	Pg. Cnt.	number
Lang	GB	SUPPL. Ident.	7563 5 7	SHEET 4 OF SHEETS 31
PROJECT #		A3-DRAWING #	407584	REV. B

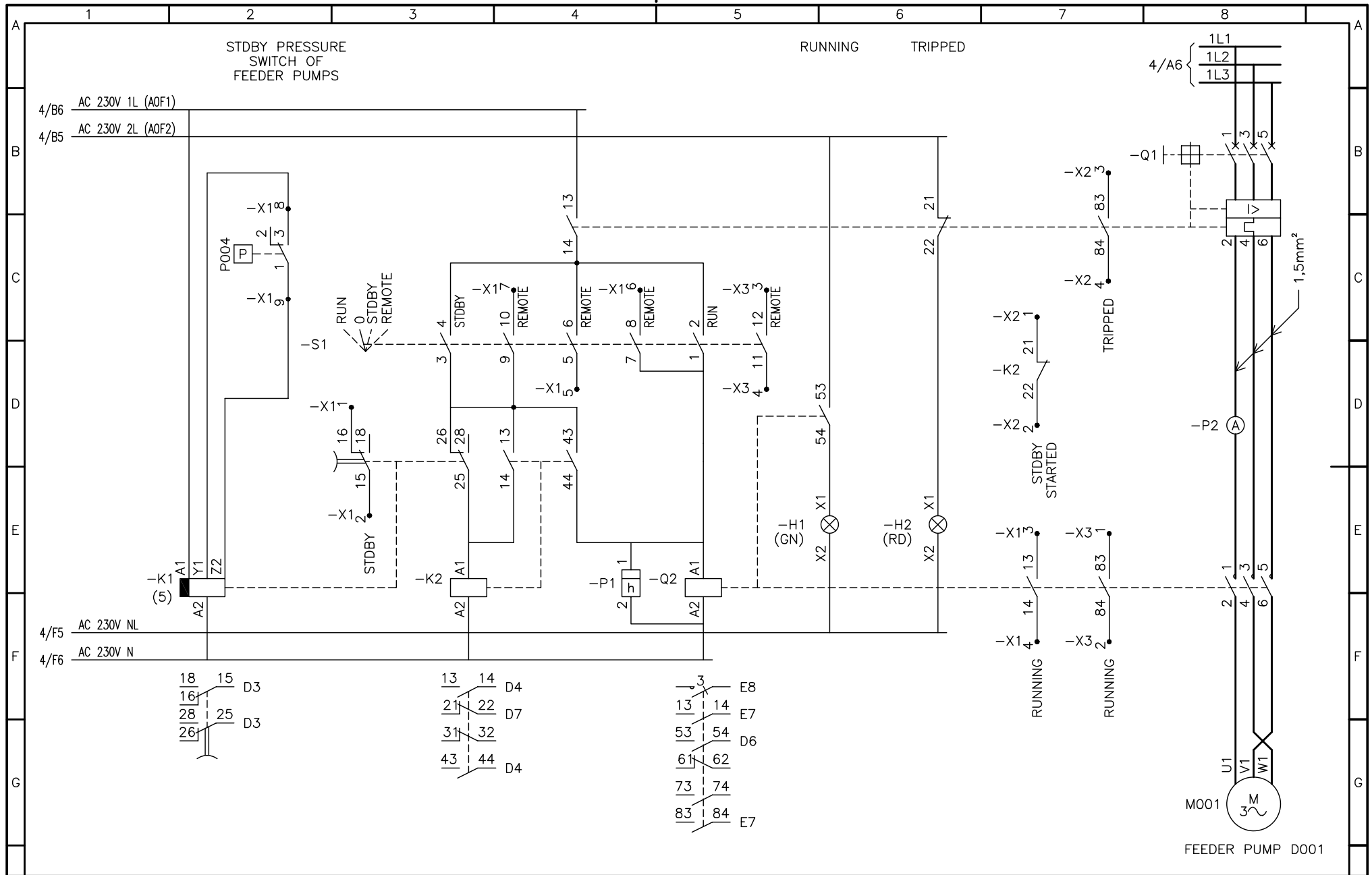

Product	AMB-M	CAD SCALE	
MADE	30.01.2007	KTa/Tammi	
CHKD.	30.01.2007	KTa/Tammi	
APPVD.	30.01.2007	RTu/Tuominen	

HUA HAI EQUIPMENT & ENG.
JNSY H2431/32/33
M/E

BOOSTER UNIT STARTER 1
FEEDER PUMP D001
Circuit Diagram

OBJECT	=E1-A1DDC	Pg. Cnt.	number
Lang	GB	Suppl. Ident.	7563 5 71
PROJECT #	1A3-DRAWING #	SHEET	5
	407584	REV.	B

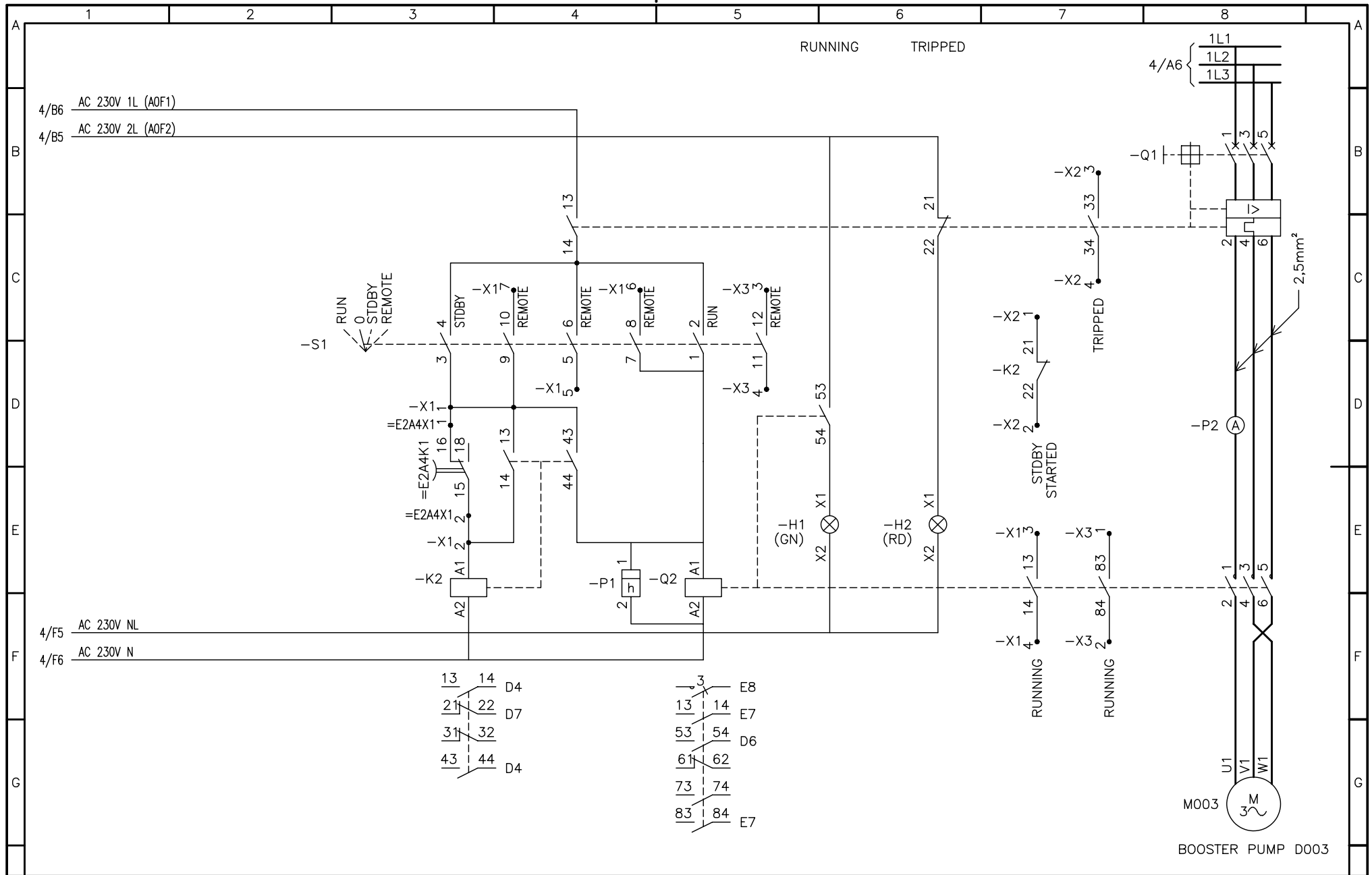

Product	AMB-M	CAD	SCALE	HUA HAI EQUIPMENT & ENG.
MADE	30.01.2007	KTa/Tammi		JNSY H2431/32/33
CHKD.	30.01.2007	KTa/Tammi		M/E
APPVD.	30.01.2007	RTu/Tuominen		

OBJECT	=E1-A3 DDC	Pg. Cnt.	number
Lang	GB	Suppl. Ident.	7563 5 7
PROJECT #	A3-DRAWING #	SHEET	6
	407584	REV.	B

OBJECT	=E1-A3 DDC	Pg. Cnt.	number
Lang	GB	Suppl. Ident.	7563 5 7
PROJECT #	A3-DRAWING #	SHEET	6
	407584	REV.	B

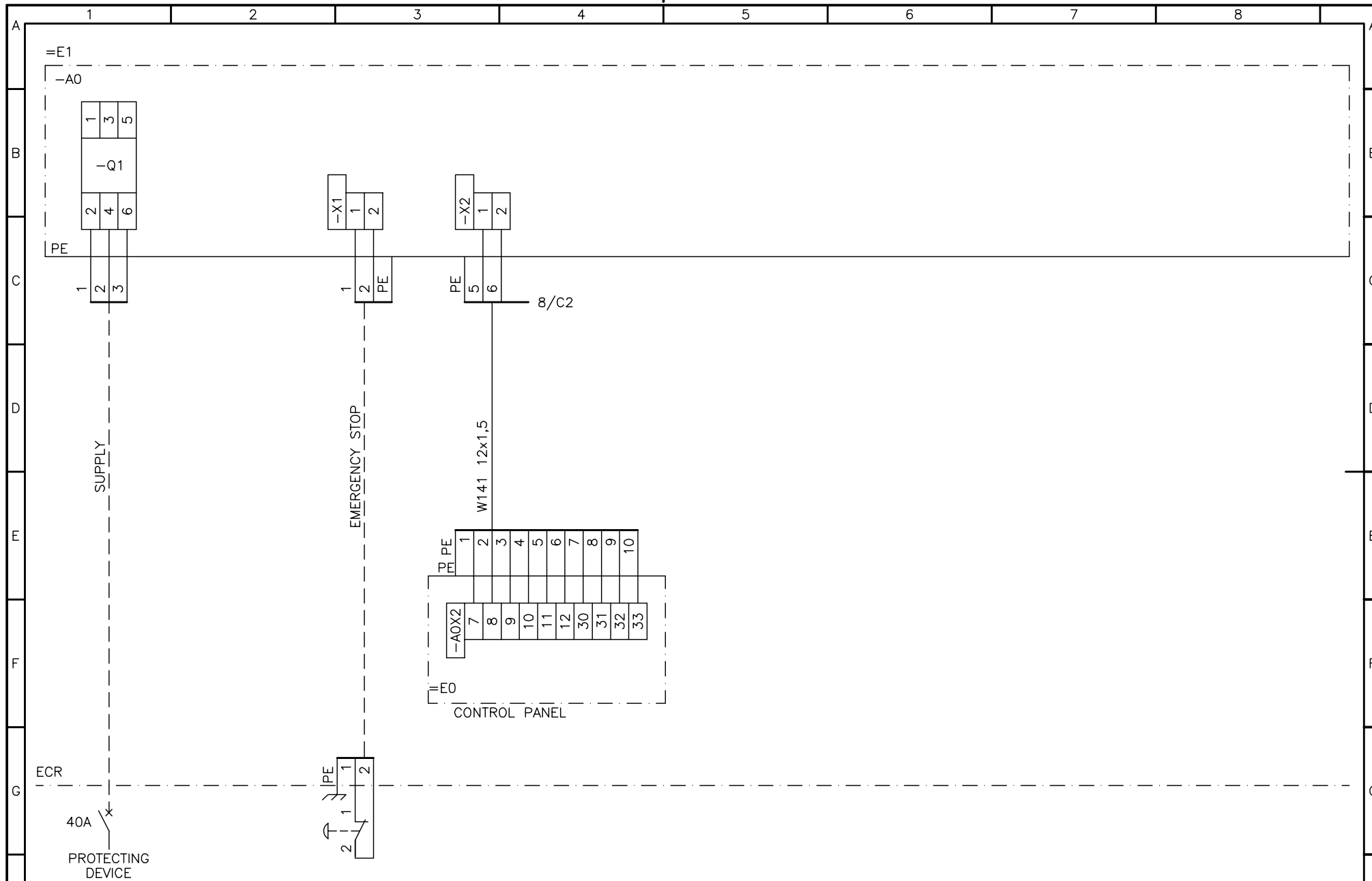

Product	AMB-M	CAD SCALE	HUA HAI EQUIPMENT & ENG.
MADE	30.01.2007	KTa/Tammi	JNSY H2431/32/33
CHKD.	30.01.2007	KTa/Tammi	M/E
APPVD.	30.01.2007	RTu/Tuominen	

BOOSTER UNIT STARTER 1
SUPPLY
Interconnection Diagram

OBJECT	=E1 DDC	Pg. Cnt.	number
Lang	GB	Suppl. Ident.	7563 5 7
PROJECT #	-	A3-DRAWING #	407584
		SHEET	7
		OF SHEETS	31
		REV.	B

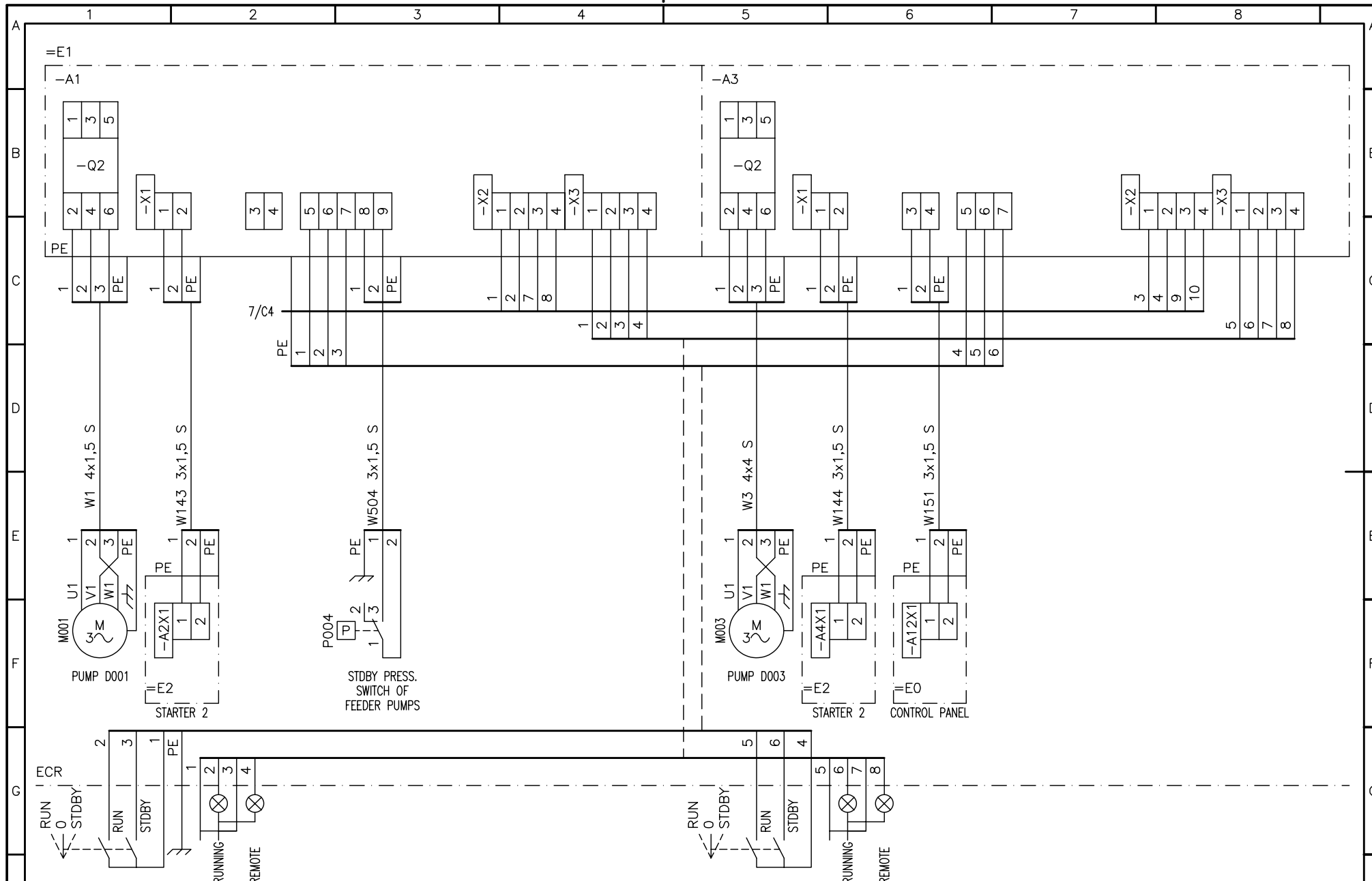

AURAMARINE Ltd
FINLAND

Product	AMB-M	SCALE	1:1
MADE	30.01.2007	KTa/Tammi	
CHKD.	30.01.2007	KTa/Tammi	
APPVD.	30.01.2007	RTu/Tuominen	

HUA HAI EQUIPMENT & ENG.
JNSY H2431/32/33
M/E

BOOSTER UNIT STARTER 1
PUMP MOTORS & SIGNALS
Interconnection Diagram

OBJECT	=E1 DDC	Pg. Cnt.	number
Lng	GB	Suppl. Ident.	7563 5 7
PROJECT #	A3-DRAWING #	SHEET	8
	407584	OF SHEETS	31
		REV.	B

WIDTH 600
 HEIGHT 380
 DEPTH 210
 COLOR RAL 7035

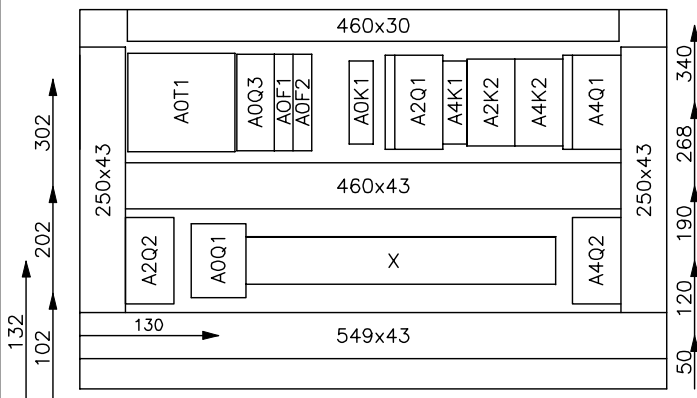
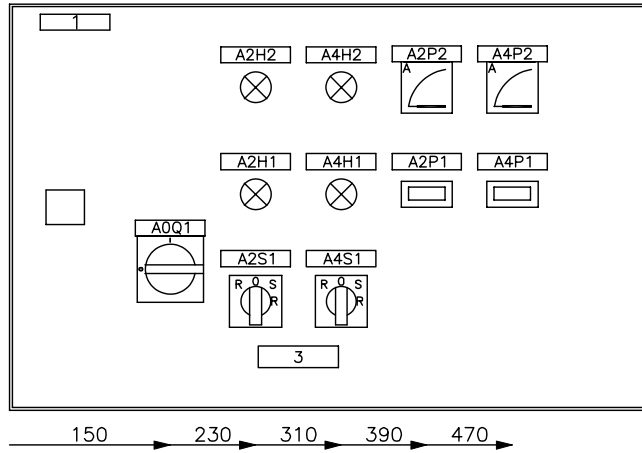

8xM20+M25
 FOR SITE CABLES:
 2xM20(φ5,5-12)+3xM25(φ11-18)+M32(φ17-25)

LIST OF LABELS

id	pcs	text
1	1	STARTER 2
A0Q1	1	MAIN SWITCH
A2S1	1	FEEDER PUMP D002
A4S1	1	BOOSTER PUMP D004
-H1	2	RUNNING
-H2	2	TRIPPED
A2P1	1	RUNNING HOURS OF FEEDER PUMP D002
-	-	
A4P1	1	RUNNING HOURS OF BOOSTER PUMP D004
-	-	
3	1	WARNING ELECTRIC MOTORS WILL START AUTOMATICALLY AFTER POWER FAILURE
A2P2	1	CURRENT OF PUMP D002 MOTOR
-	-	
A4P2	1	CURRENT OF PUMP D004 MOTOR
-	-	

AC 440V 60Hz



Product	AMB-M	CAD	SCALE
MADE	30.01.2007	KTa/Tammi	
CHKD.	30.01.2007	KTa/Tammi	
APPVD.	30.01.2007	RTu/Tuominen	

HUA HAI EQUIPMENT & ENG.
 JNSY H2431/32/33
 M/E

BOOSTER UNIT STARTER 2
 Assembly Drawing

OBJECT	=E2 DDC	Pg. Cnt.	
Lng	GB	Suppl. Ident.	7563 5 7
PROJECT #		SHEET	9
		OF SHEETS	31
	A3-DRAWING #	REV.	
	407584	B	

b. Cable gland added 13072007 KTa

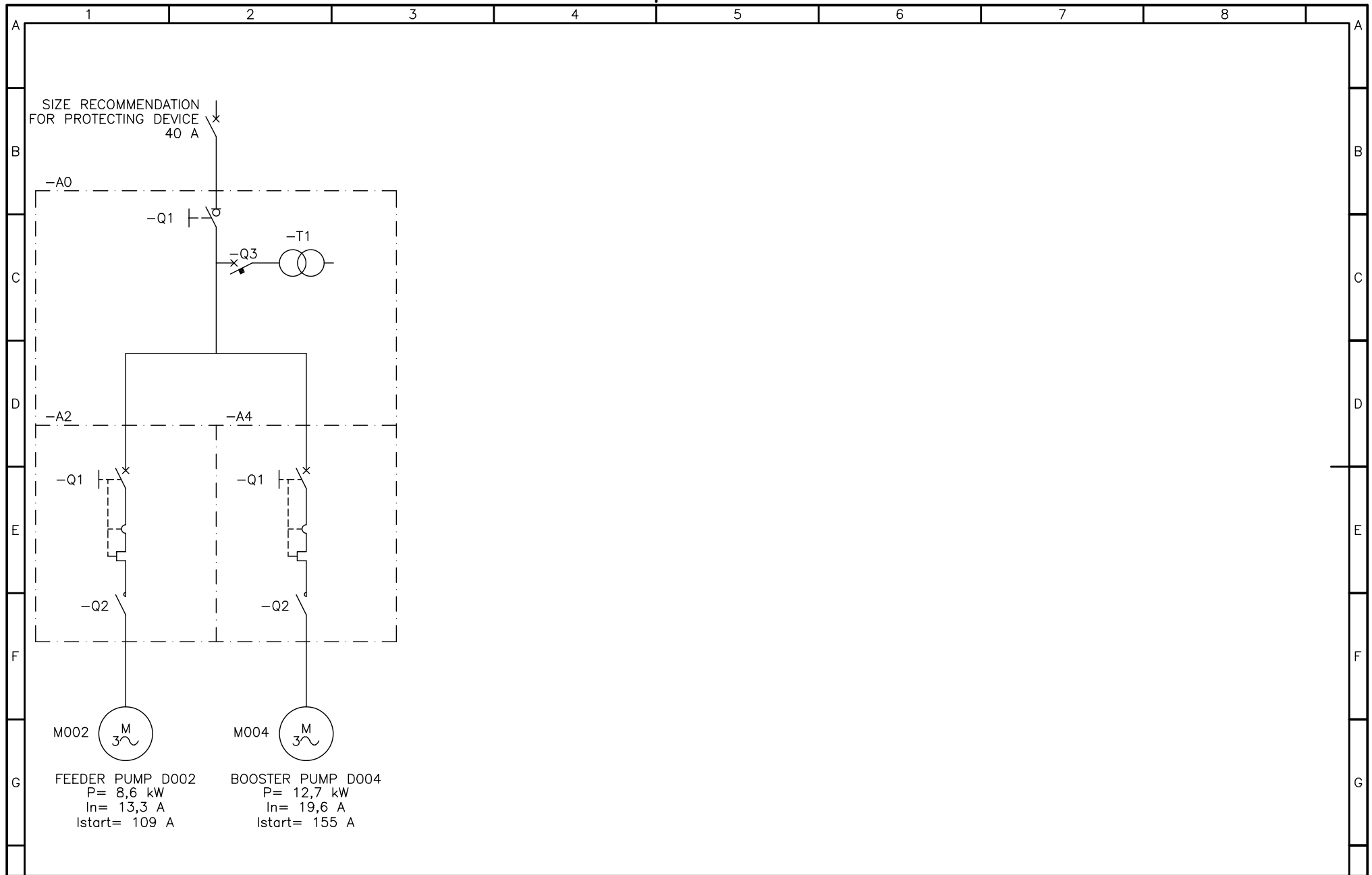

Product	AMB-M	CAD	SCALE
MADE	30.01.2007	KTa/Tammi	
CHKD.	30.01.2007	KTa/Tammi	
APPVD.	30.01.2007	RTu/Tuominen	

HUA HAI EQUIPMENT & ENG.
JNSY H2431/32/33
M/E

BOOSTER UNIT STARTER 2
POWER DISTRIBUTION
Single Line Diagram

OBJECT	=E2 DDC	Pg. Cnt.	number
LnG GB SUPP. Ident.	7563 5 7	SHEET	10 OF SHEETS 31
PROJECT #	A3-DRAWING #	REV.	
-	407584	B	

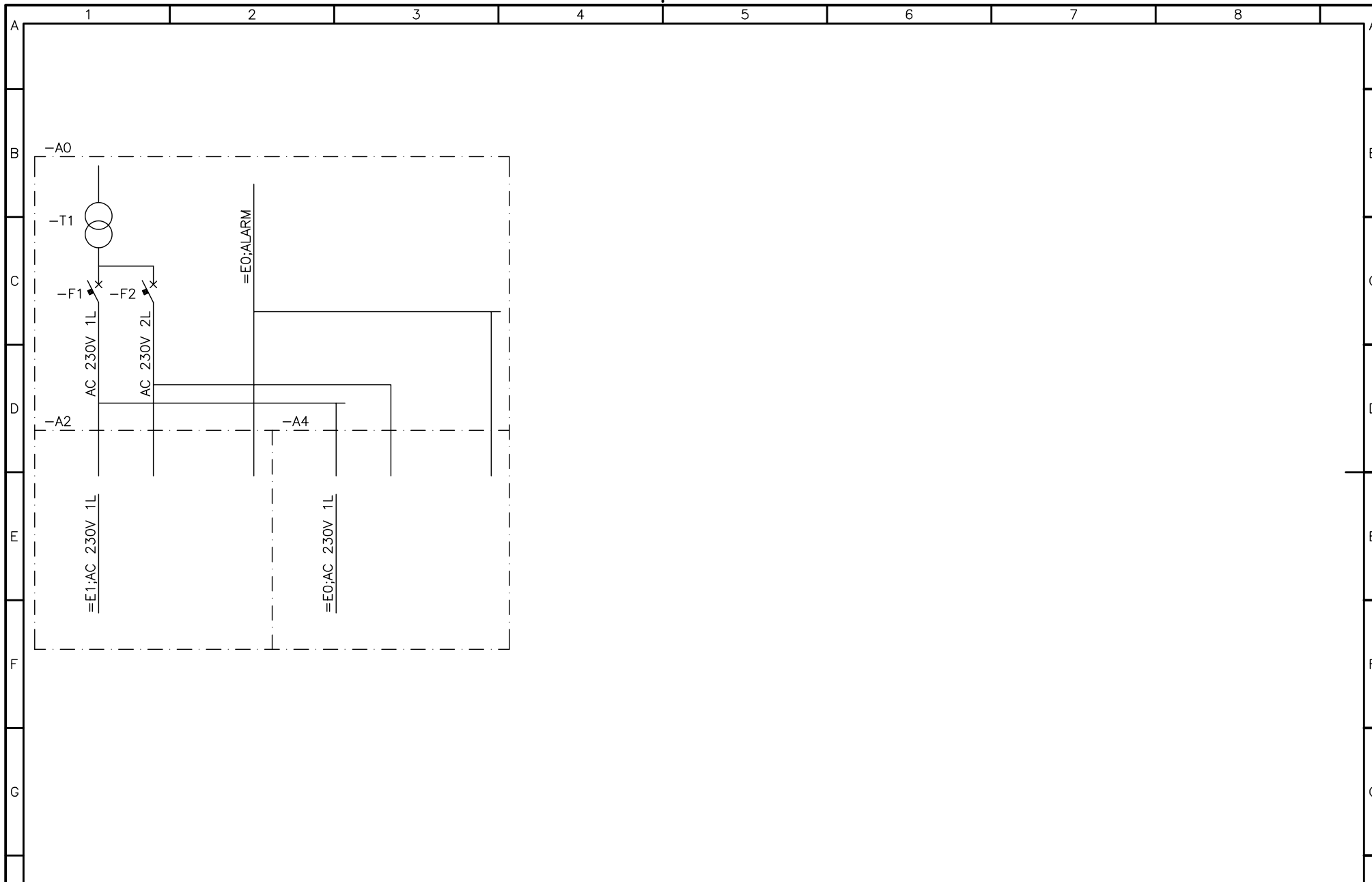

AURAMARINE Ltd
FINLAND

Product	AMB-M	CAD	SCALE
MADE	30.01.2007	KTa/Tammi	
CHKD.	30.01.2007	KTa/Tammi	
APPVD.	30.01.2007	RTu/Tuominen	

HUA HAI EQUIPMENT & ENG.
JNSY H2431/32/33
M/E

BOOSTER UNIT STARTER 2
CONTROL VOLTAGE DISTRIBUTION
Single Line Diagram

OBJECT	=E2 DDC	Pg. Cnt.	
LnG GB SUPP. Ident.	7563 5 7	SHEET 1	OF SHEETS 31
PROJECT #	A3-DRAWING #	REV.	
-	407584	B	

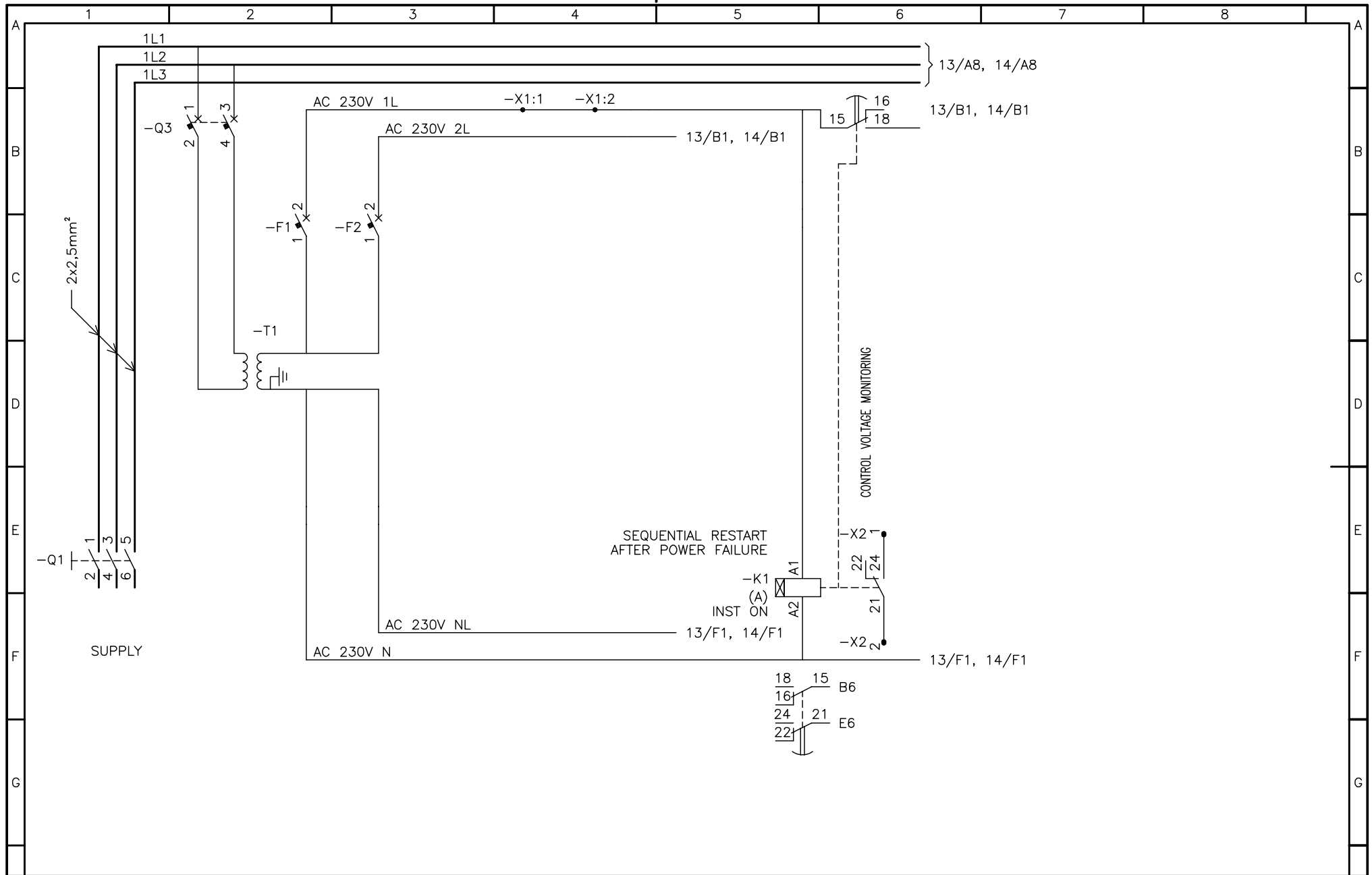

Product	AMB-M	SCALE	1:1
MADE	30.01.2007	KTa/Tammi	
CHKD.	30.01.2007	KTa/Tammi	
APPVD.	30.01.2007	RTu/Tuominen	

HUA HAI EQUIPMENT & ENG.
JNSY H2431/32/33
M/E

BOOSTER UNIT STARTER 2
SUPPLY
Circuit Diagram

OBJECT	=E2-A0	DDC	Pg. Cnt.	number
Lang	GB	SUPPL. Ident.	7563 5 7	SHEET 12 OF SHEETS 31
PROJECT #		A3-DRAWING #	407584	REV. B

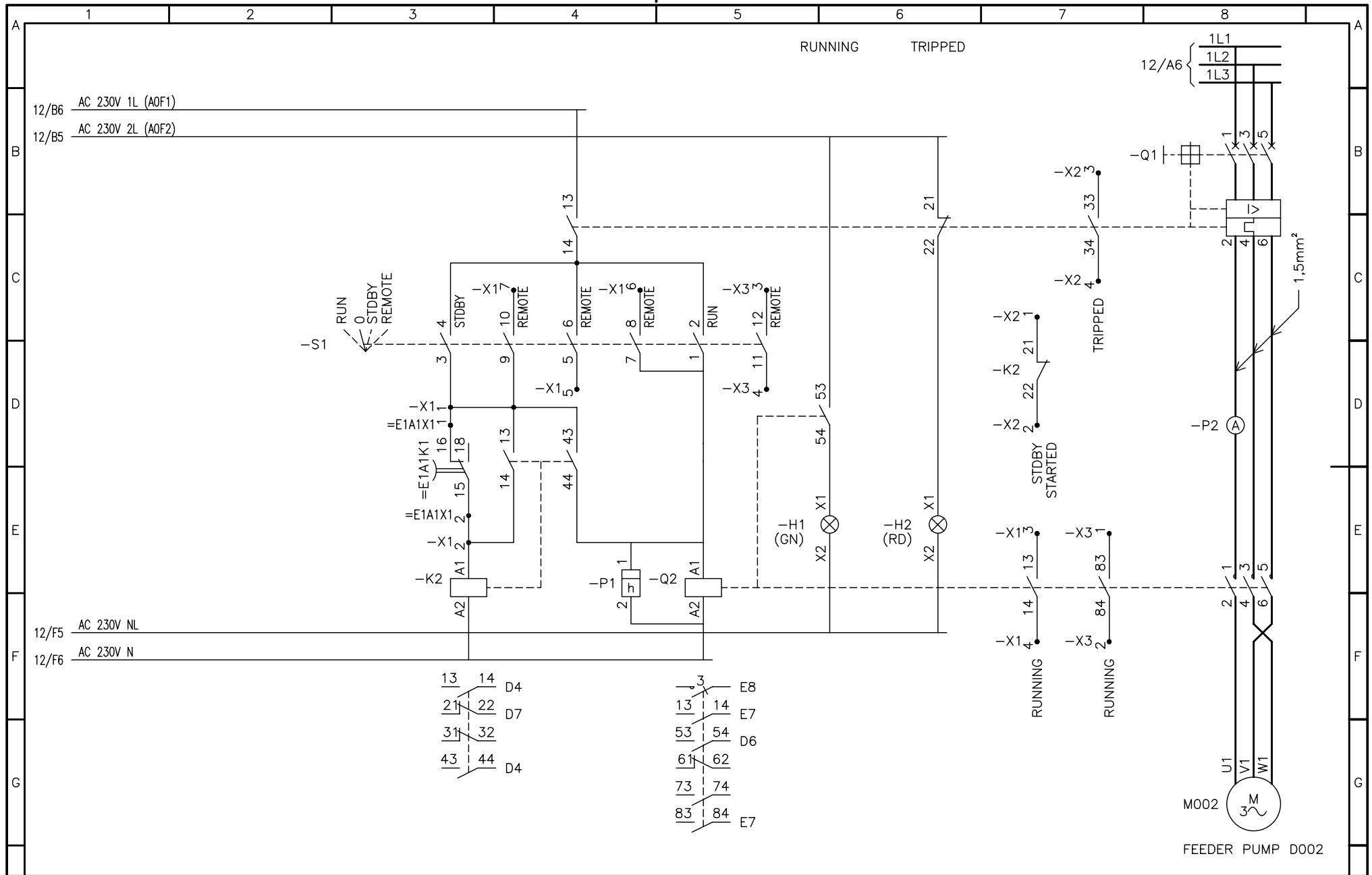

Product	AMB-M	CAD	SCALE
MADE	30.01.2007	KTa/Tammi	
CHKD.	30.01.2007	KTa/Tammi	
APPVD.	30.01.2007	RTu/Tuominen	

HUA HAI EQUIPMENT & ENG.
JNSY H2431/32/33
M/E

BOOSTER UNIT STARTER 2
FEEDER PUMP D002
Circuit Diagram

OBJECT	=E2-A2	DDC	Pg. Cnt.	number
Lang	GB	Suppl. Ident.	7563 5 7	SHEET 13
PROJECT #	A3-DRAWING #		407584	REV. B
				SHETS 31

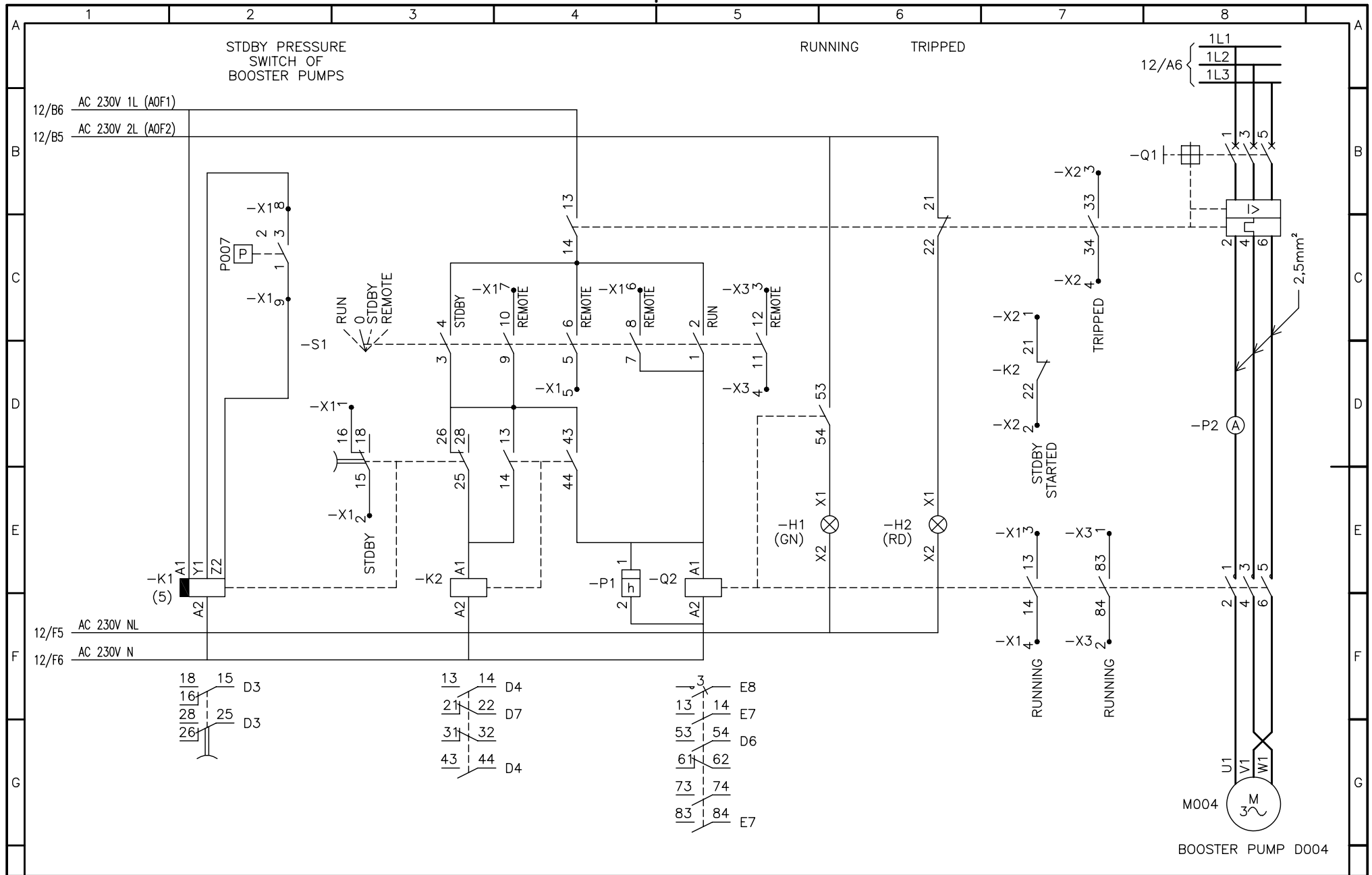

Product	AMB-M	CAD	SCALE
MADE	30.01.2007	KTa/Tammi	
CHKD.	30.01.2007	KTa/Tammi	
APPVD.	30.01.2007	RTu/Tuominen	

HUA HAI EQUIPMENT & ENG.
JNSY H2431/32/33
M/E

BOOSTER UNIT STARTER 2
BOOSTER PUMP D004
Circuit Diagram

OBJECT	=E2-A4 DDC	Pg. Cnt.	number
Lang	GB	Suppl. Ident.	7563 5 7
PROJECT #	407584	SHEET	14
		REV.	B
		SHETS	31

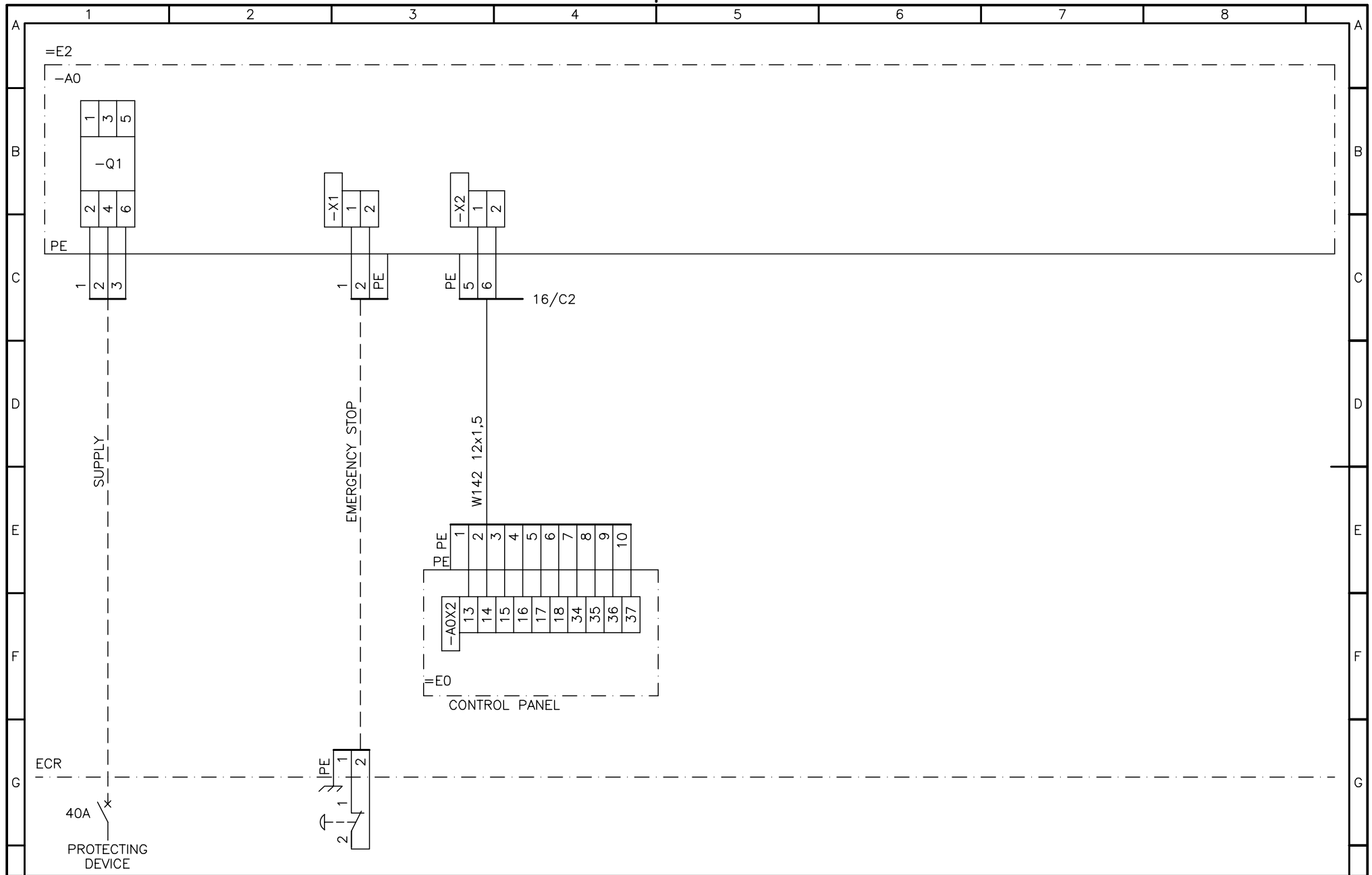

Product	AMB-M	CAD	SCALE
MADE	30.01.2007	KTa/Tammi	
CHKD.	30.01.2007	KTa/Tammi	
APPVD.	30.01.2007	RTu/Tuominen	

HUA HAI EQUIPMENT & ENG.
JNSY H2431/32/33
M/E

BOOSTER UNIT STARTER 2
SUPPLY
Interconnection Diagram

OBJECT	=E2 DDC	Pg. Cnt.	number
Lang	GB	SUPPL. Ident.	7563 5 7
		SHEET	15
PROJECT #		OF SHEETS	31
		REV.	B
		A3-DRAWING #	407584

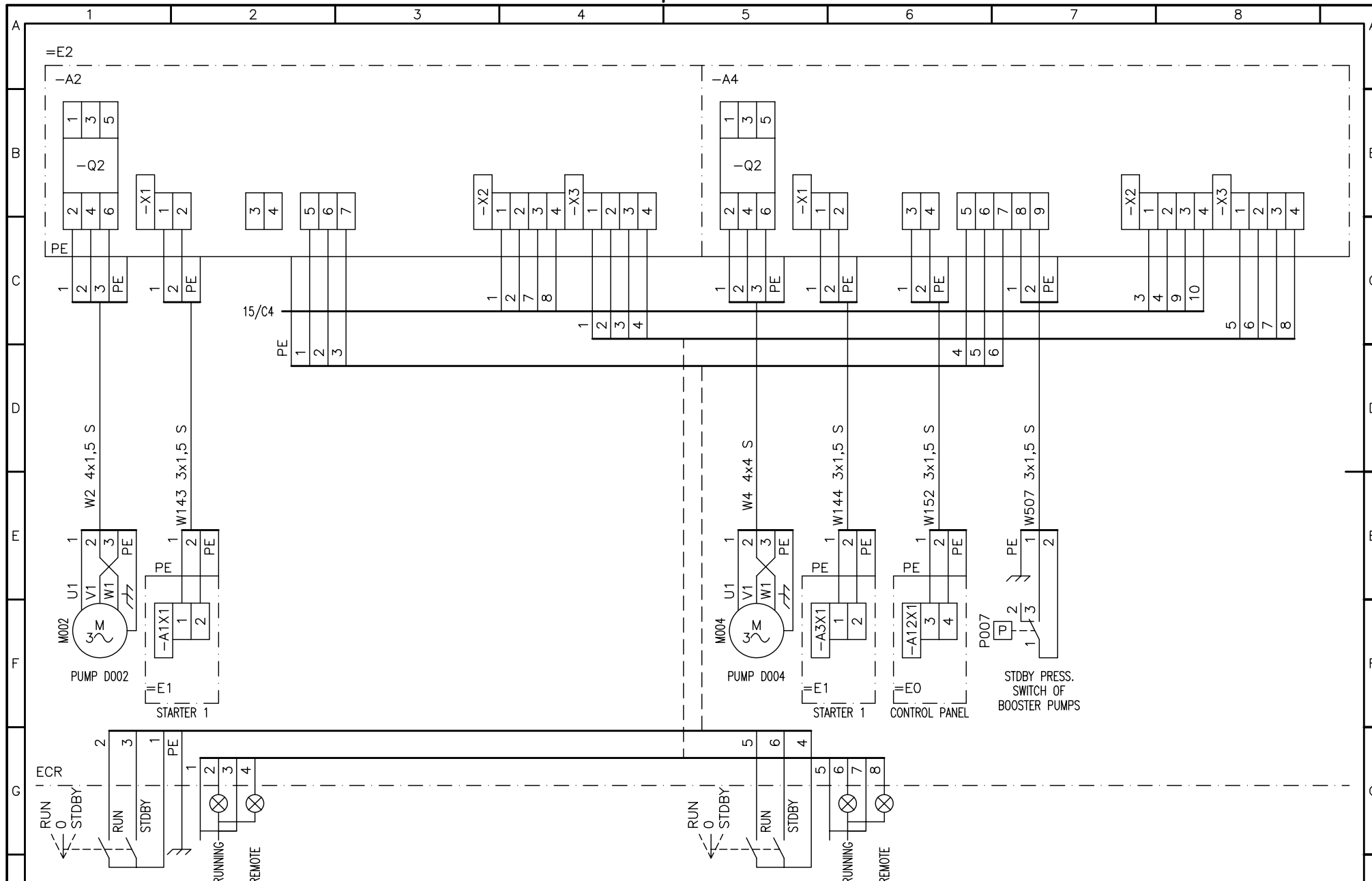

Product	AMB-M	CAD SCALE
MADE	30.01.2007	KTa/Tammi
CHKD.	30.01.2007	KTa/Tammi
APPVD.	30.01.2007	RTu/Tuominen

HUA HAI EQUIPMENT & ENG.
JNSY H2431/32/33
M/E

BOOSTER UNIT STARTER 2
PUMP MOTORS & SIGNALS
Interconnection Diagram

OBJECT	=E2 DDC	Pg. Cnt.	number
Lang	GB	Suppl. Ident.	7563 5 7
PROJECT #	A3-DRAWING #	SHEET	16
-	407584	OF SHEETS	31
		REV.	B

a AON1 removed 1604207 KTa

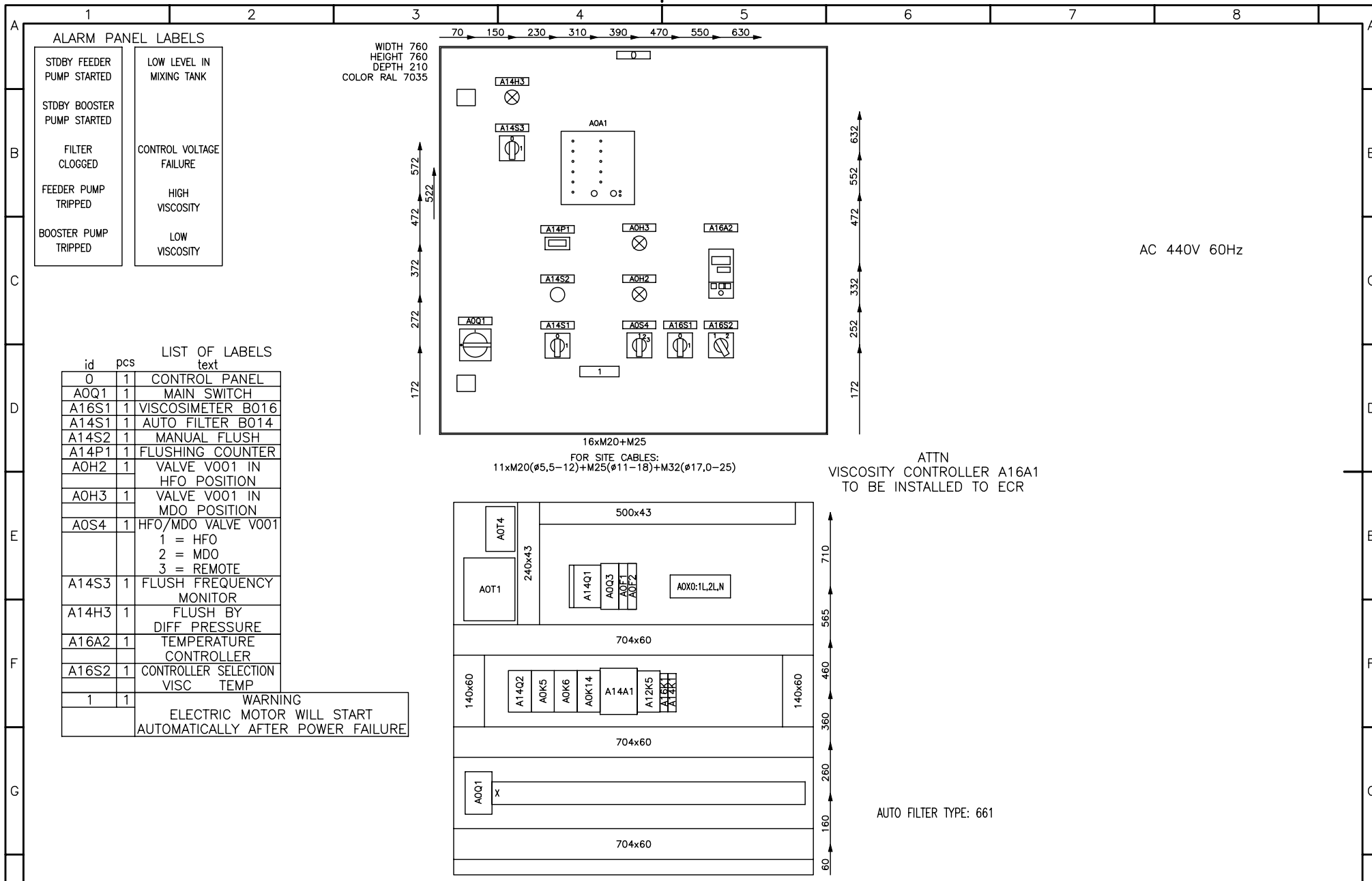

AC 440V 60Hz

ATTN
VISCOSITY CONTROLLER A16A1
TO BE INSTALLED TO ECR

AUTO FILTER TYPE: 661

ALARM PANEL LABELS

STDBY FEEDER PUMP STARTED	LOW LEVEL IN MIXING TANK
STDBY BOOSTER PUMP STARTED	CONTROL VOLTAGE FAILURE
FILTER CLOGGED	HIGH VISCOSITY
FEEDER PUMP TRIPPED	LOW VISCOSITY
BOOSTER PUMP TRIPPED	

LIST OF LABELS

id	pcs	text
0	1	CONTROL PANEL
AOQ1	1	MAIN SWITCH
A16S1	1	VISCOSIMETER B016
A14S1	1	AUTO FILTER B014
A14S2	1	MANUAL FLUSH
A14P1	1	FLUSHING COUNTER
A0H2	1	VALVE V001 IN HFO POSITION
A0H3	1	VALVE V001 IN MDO POSITION
A0S4	1	HFO/MDO VALVE V001 1 = HFO 2 = MDO 3 = REMOTE
A14S3	1	FLUSH FREQUENCY MONITOR
A14H3	1	FLUSH BY DIFF PRESSURE
A16A2	1	TEMPERATURE CONTROLLER
A16S2	1	CONTROLLER SELECTION VISC TEMP
1	1	WARNING ELECTRIC MOTOR WILL START AUTOMATICALLY AFTER POWER FAILURE

WIDTH 760
HEIGHT 760
DEPTH 210
COLOR RAL 7035

16xM20+M25
FOR SITE CABLES:
11xM20(ø5,5-12)+M25(ø11-18)+M32(ø17,0-25)



Product	AMB-M	CAD SCALE	HUA HAI EQUIPMENT & ENG.
MADE	30.01.2007	KTa/Tammi	JNSY H2431/32/33
CHKD.	30.01.2007	KTa/Tammi	M/E
APPVD.	30.01.2007	RTu/Tuominen	

BOOSTER UNIT CONTROL PANEL
Assembly Drawing

OBJECT	=E0DDC	Pg. Cnt.	number
Lng	GB	Suppl. Ident.	7563 5 7
PROJECT #	A3-DRAWING #	SHEET	17
		OF SHEETS	31
		REV.	B
			407584

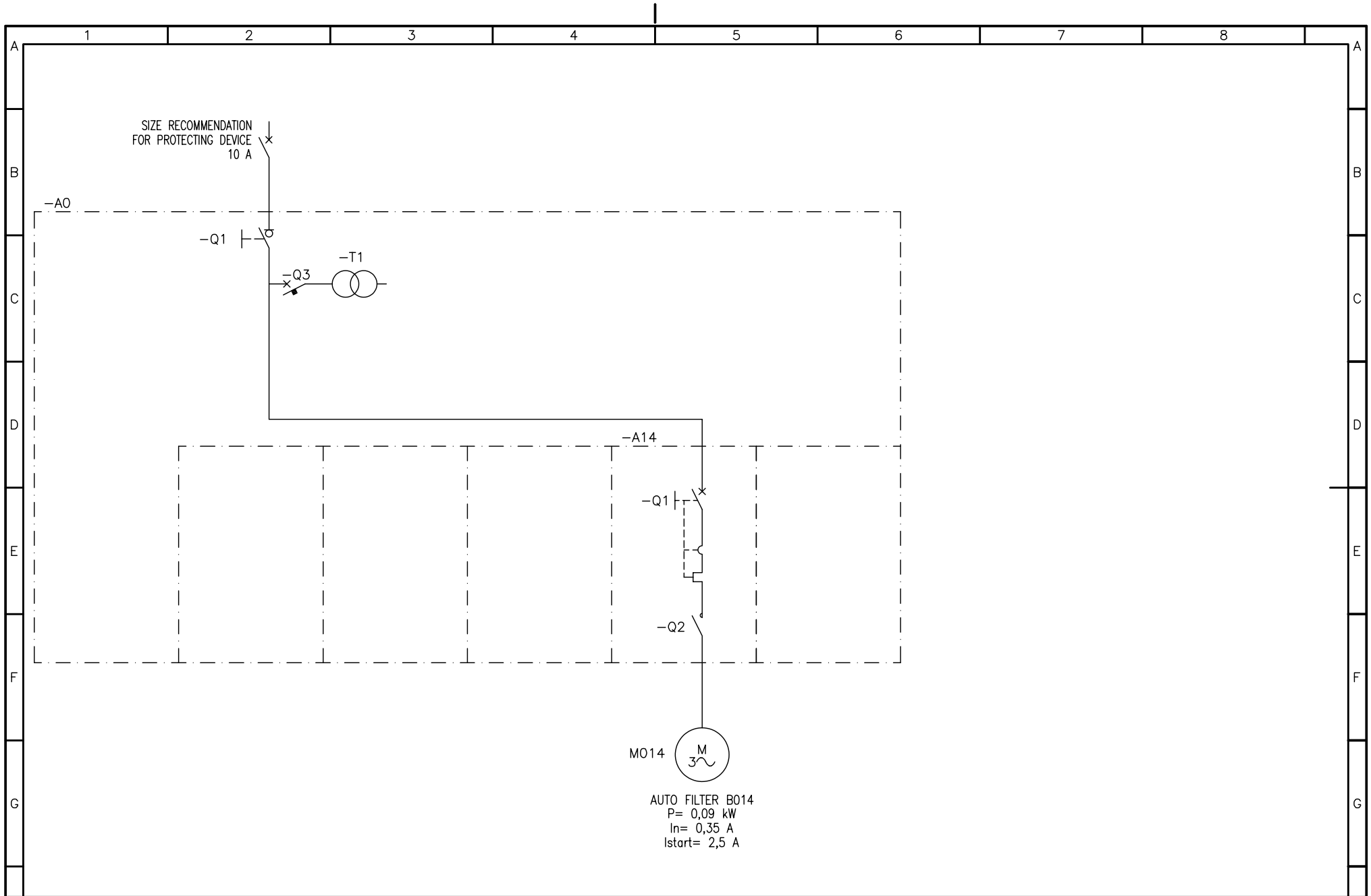

SIZE RECOMMENDATION
FOR PROTECTING DEVICE
10 A

-A0

-Q1

-Q3

-T1

-A14

-Q1

-Q2

M014



AUTO FILTER B014
P= 0,09 kW
In= 0,35 A
Istart= 2,5 A



Product	AMB-M	CAD	SCALE
MADE	30.01.2007	KTa/Tammi	
CHKD.	30.01.2007	KTa/Tammi	
APPVD.	30.01.2007	RTu/Tuominen	

HUA HAI EQUIPMENT & ENG.
JNSY H2431/32/33
M/E

BOOSTER UNIT CONTROL PANEL
POWER DISTRIBUTION
Single Line Diagram

OBJECT	=E0	DDC	Pg. Cnt.
LnG	GB	Suppl. Ident.	7563 5 7
PROJECT #	-	A3-DRAWING #	407584
		SHEET	18
		OF SHEETS	31
		REV.	B

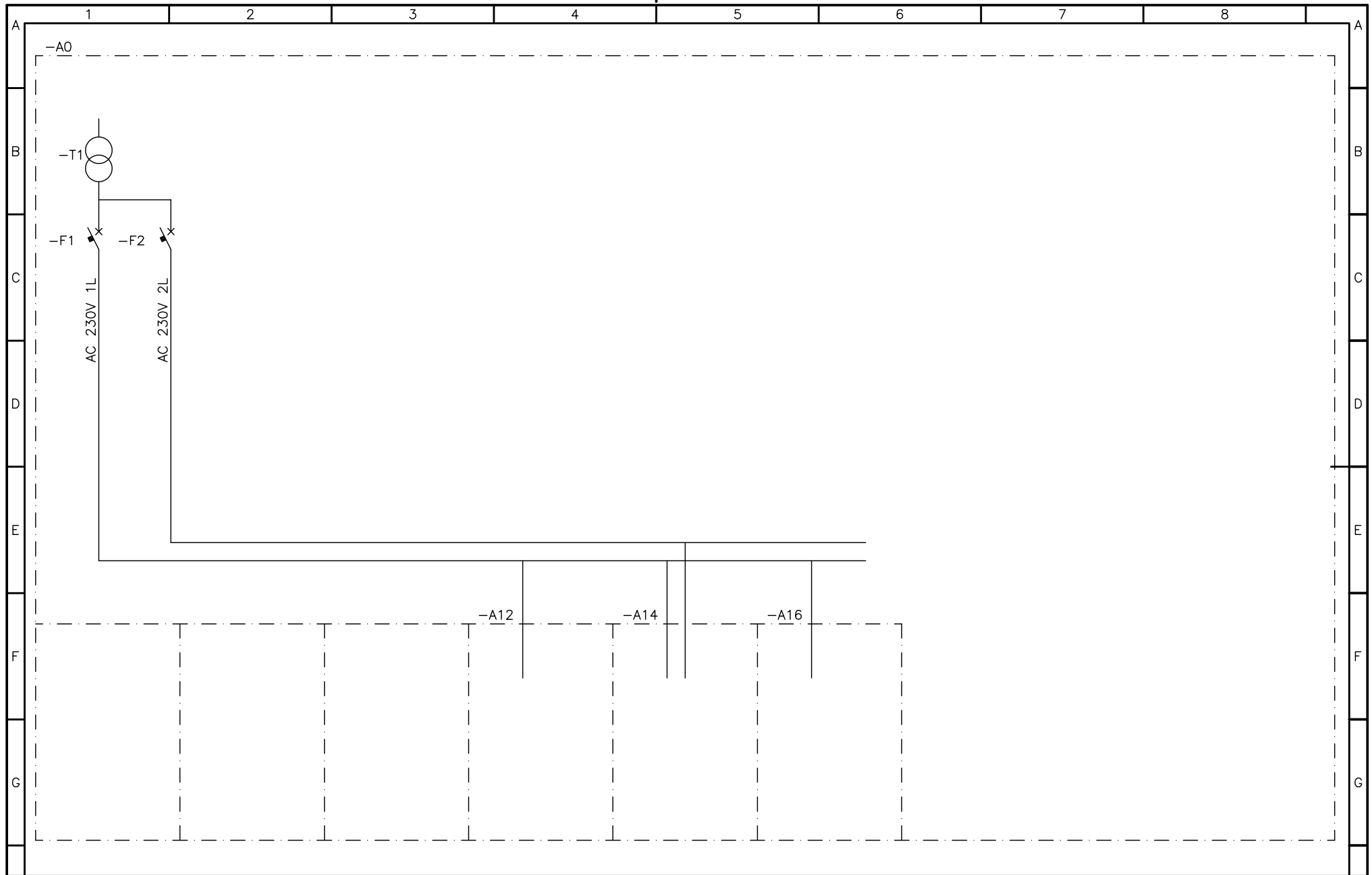

AURAMARINE Ltd
FINLAND

Product	AMB-M	CAD	SCALE
MADE	30.01.2007	KTa/Tammi	
CHKD.	30.01.2007	KTa/Tammi	
APPVD.	30.01.2007	RTu/Tuominen	

HUA HAI EQUIPMENT & ENG.
JNSY H2431/32/33
M/E

BOOSTER UNIT CONTROL PANEL
CONTROL VOLTAGE DISTRIBUTION
Single Line Diagram

OBJECT	=E0	DDC	Pg. Cnt.
LnG	GB	Suppl. Ident.	7563 5 7
PROJECT #	-	A3-DRAWING #	407584
		SHEET	19
		OF SHEETS	31
		REV.	B

a Connections to DC power supply added 16042007 KTa

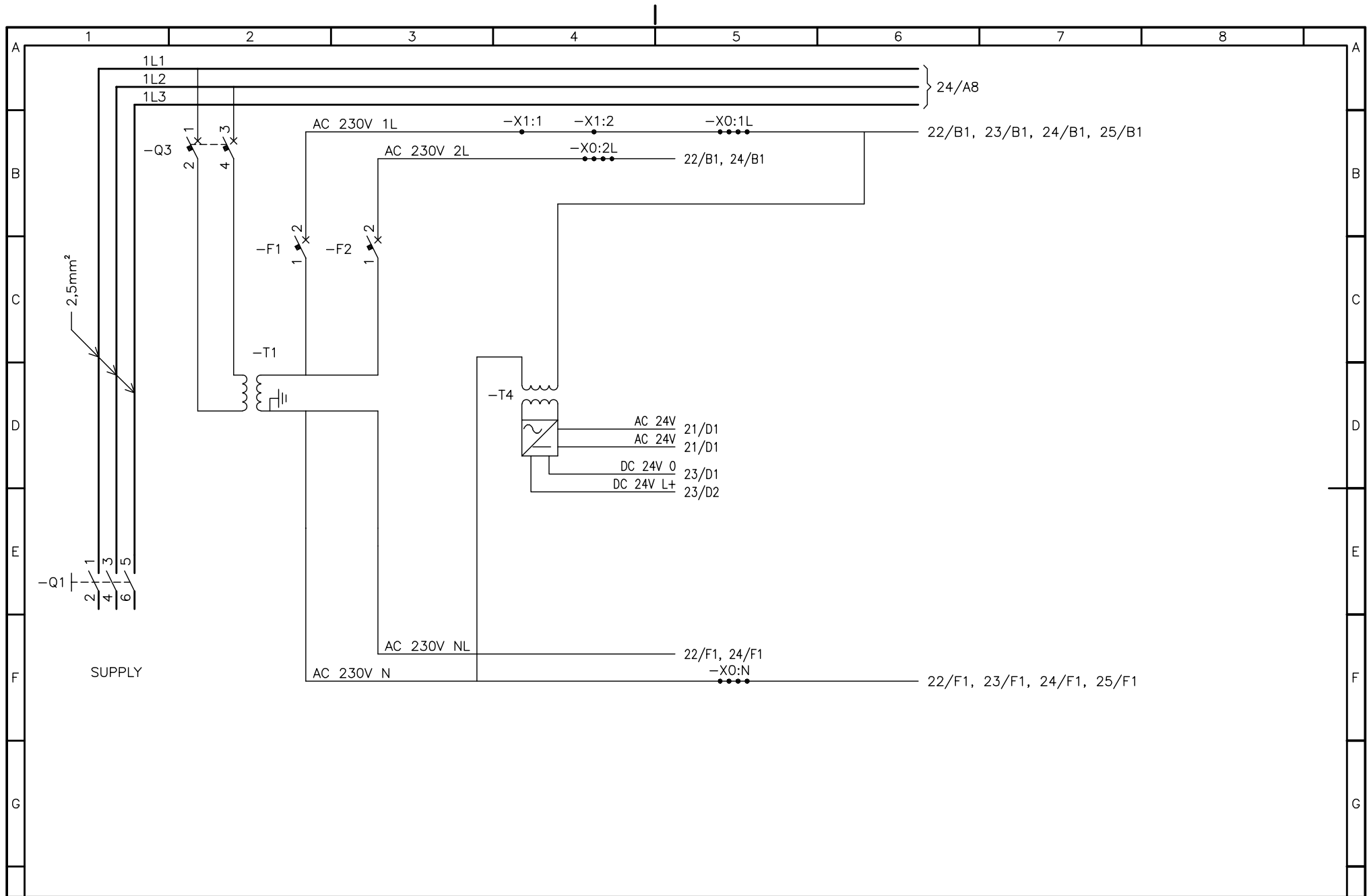

Product	AMB-M	CAD	SCALE
MADE	30.01.2007	KTa/Tammi	
CHKD.	30.01.2007	KTa/Tammi	
APPVD.	30.01.2007	RTu/Tuominen	

HUA HAI EQUIPMENT & ENG.
JNSY H2431/32/33
M/E

BOOSTER UNIT CONTROL PANEL
SUPPLY
Circuit Diagram

OBJECT	=E0-A0	DDC	Pg. Cnt.	number
Lang	GB	Suppl. Ident.	7563 5 7	SHEET 20 OF SHEETS 31
PROJECT #	-	A3-DRAWING #	407584	REV. B

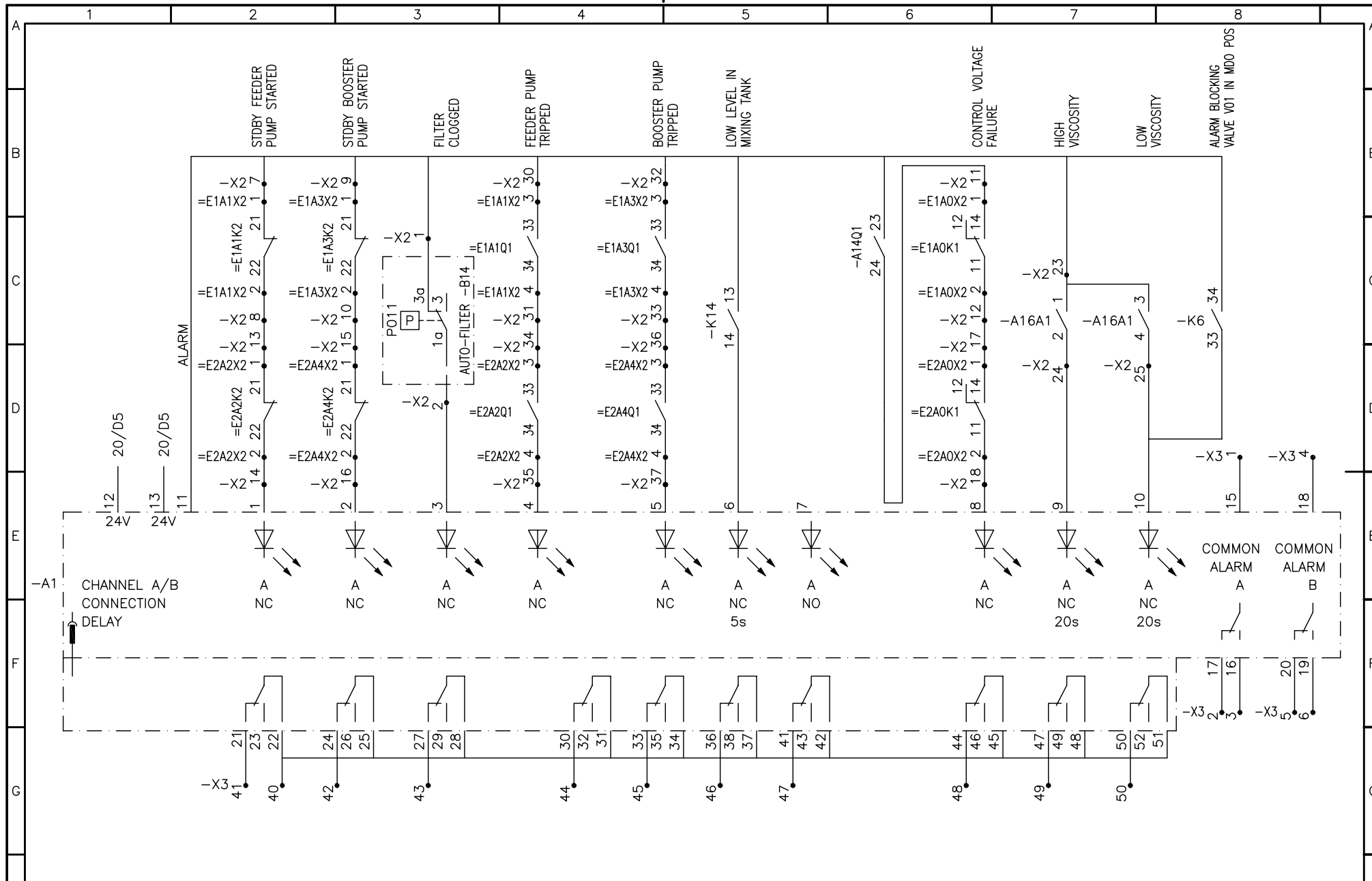

AURAMARINE Ltd
FINLAND

Product	AMB-M	CAD	SCALE
MADE	30.01.2007	KTa/Tammi	
CHKD.	30.01.2007	KTa/Tammi	
APPVD.	30.01.2007	RTu/Tuominen	

HUA HAI EQUIPMENT & ENG.
JNSY H2431/32/33
M/E

BOOSTER UNIT CONTROL PANEL
ALARMS
Circuit Diagram

OBJECT	=E0-A0	DDC	Pg. Cnt.
Lng	GB	Suppl. Ident.	7563 5 7
PROJECT #	1A3-DRAWING #	SHEET	21
	407584	SHEETS	31
		REV.	B

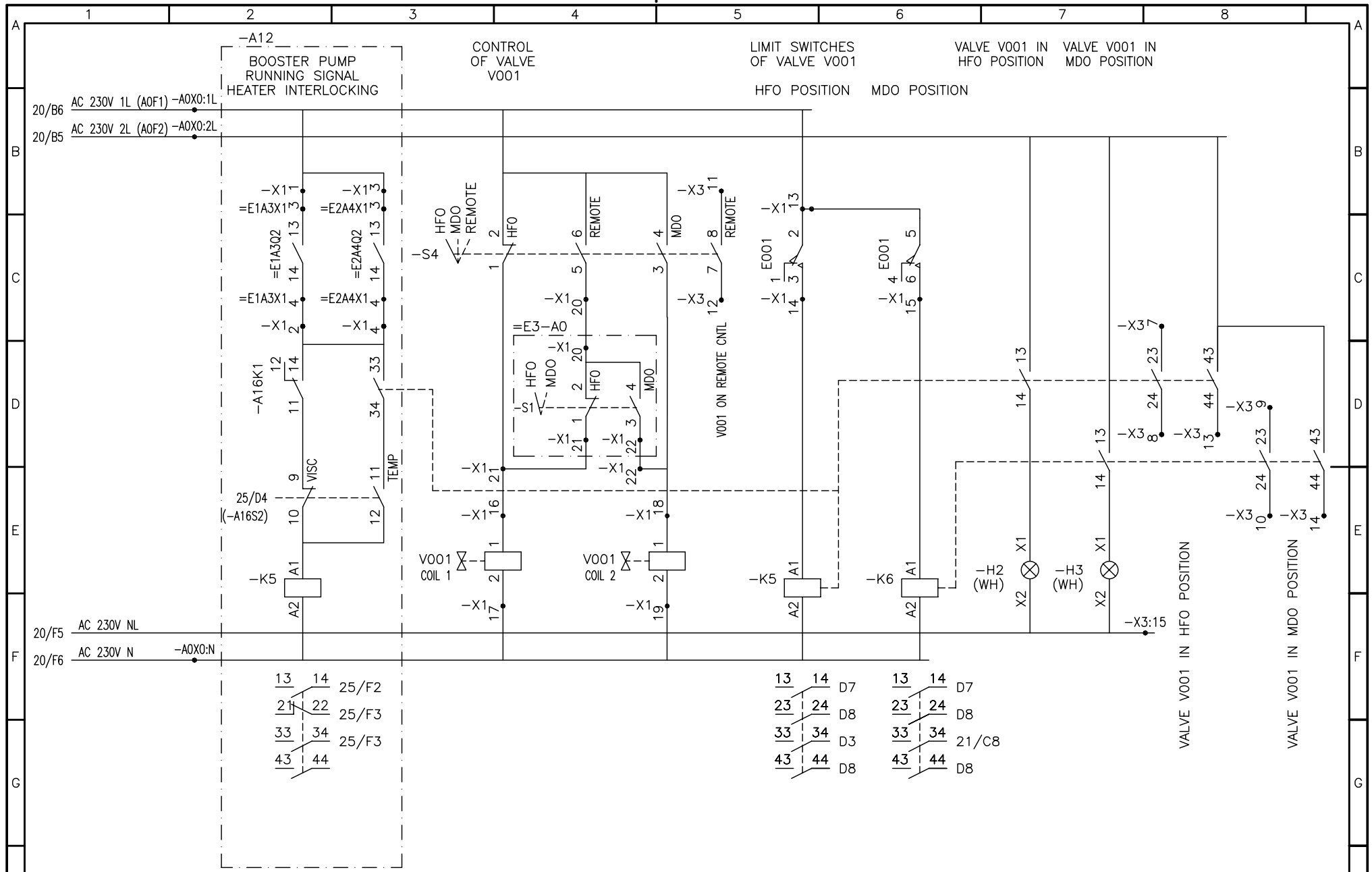

Product	AMB-M	SCALE	CAD
MADE	30.01.2007	KTa/Tammi	
CHKD.	30.01.2007	KTa/Tammi	
APPVD.	30.01.2007	RTu/Tuominen	

HUA HAI EQUIPMENT & ENG.
JNSY H2431/32/33
M/E

BOOSTER UNIT CONTROL PANEL
HEATER INTERLOCKINGS, VALVE V001, SIGNALS
Circuit Diagram

OBJECT	=E0-A0,A12	DDC	Pg. Cnt.	number
Lang	GB	SUPPL. Ident.	7563 5 7	SHEET 22
PROJECT #		A3-DRAWING #		SHEETS 31
			407584	REV. B

a Flow meter type changed 16032007 KTa

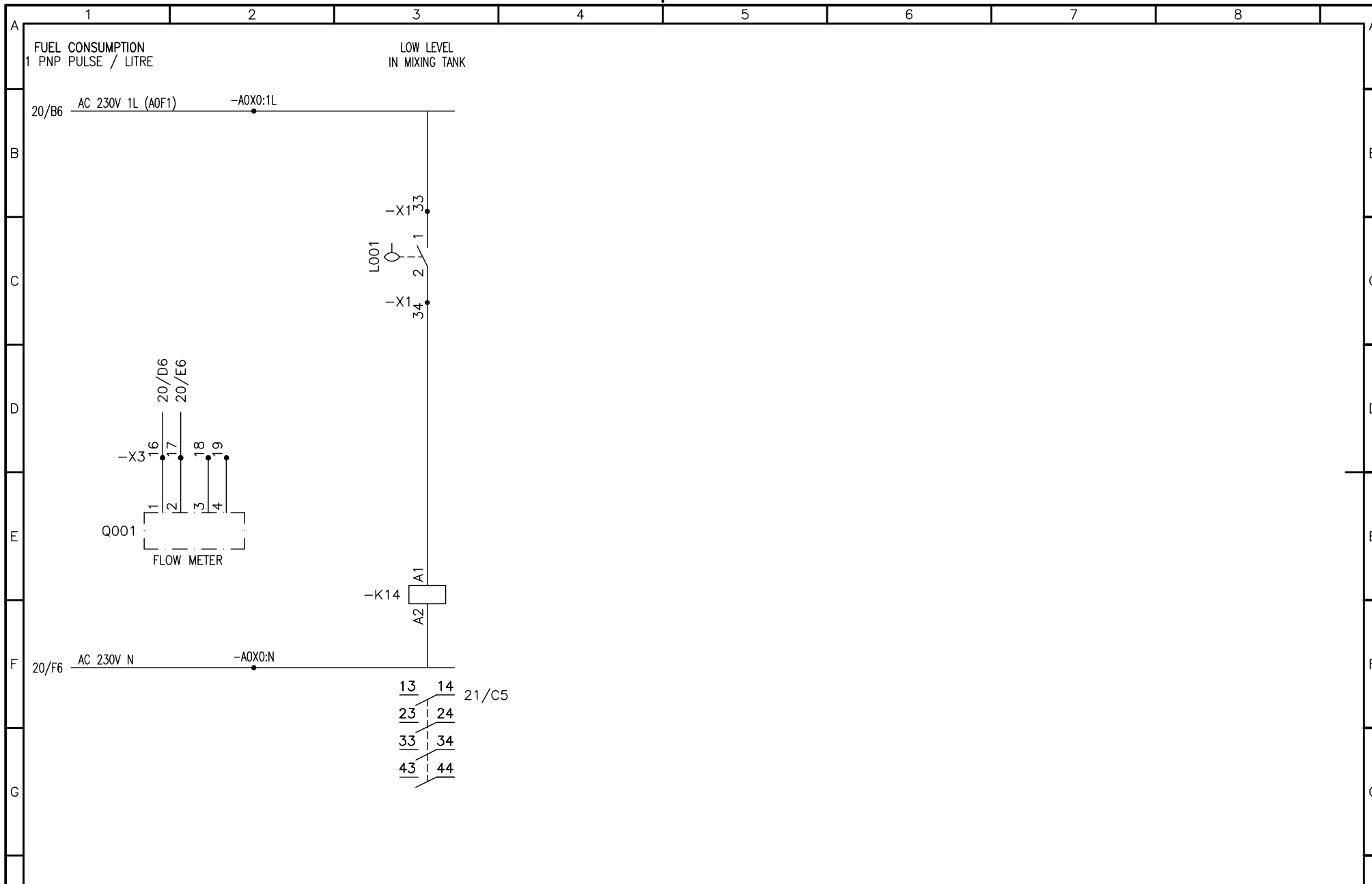

Product	AMB-M	CAD	SCALE
MADE	30.01.2007	KTa/Tammi	
CHKD.	30.01.2007	KTa/Tammi	
APPVD.	30.01.2007	RTu/Tuominen	

HUA HAI EQUIPMENT & ENG.
JNSY H2431/32/33
M/E

BOOSTER UNIT CONTROL PANEL
SIGNALS, ALARMS
Circuit Diagram

OBJECT	=E0-A0,A10	DDC	Pg. Cnt.	number
Lang	GB	SUPPL. Ident.	7563 5 7	SHEET 23 OF SHEETS 31
PROJECT #	-	A3-DRAWING #	407584	REV. B

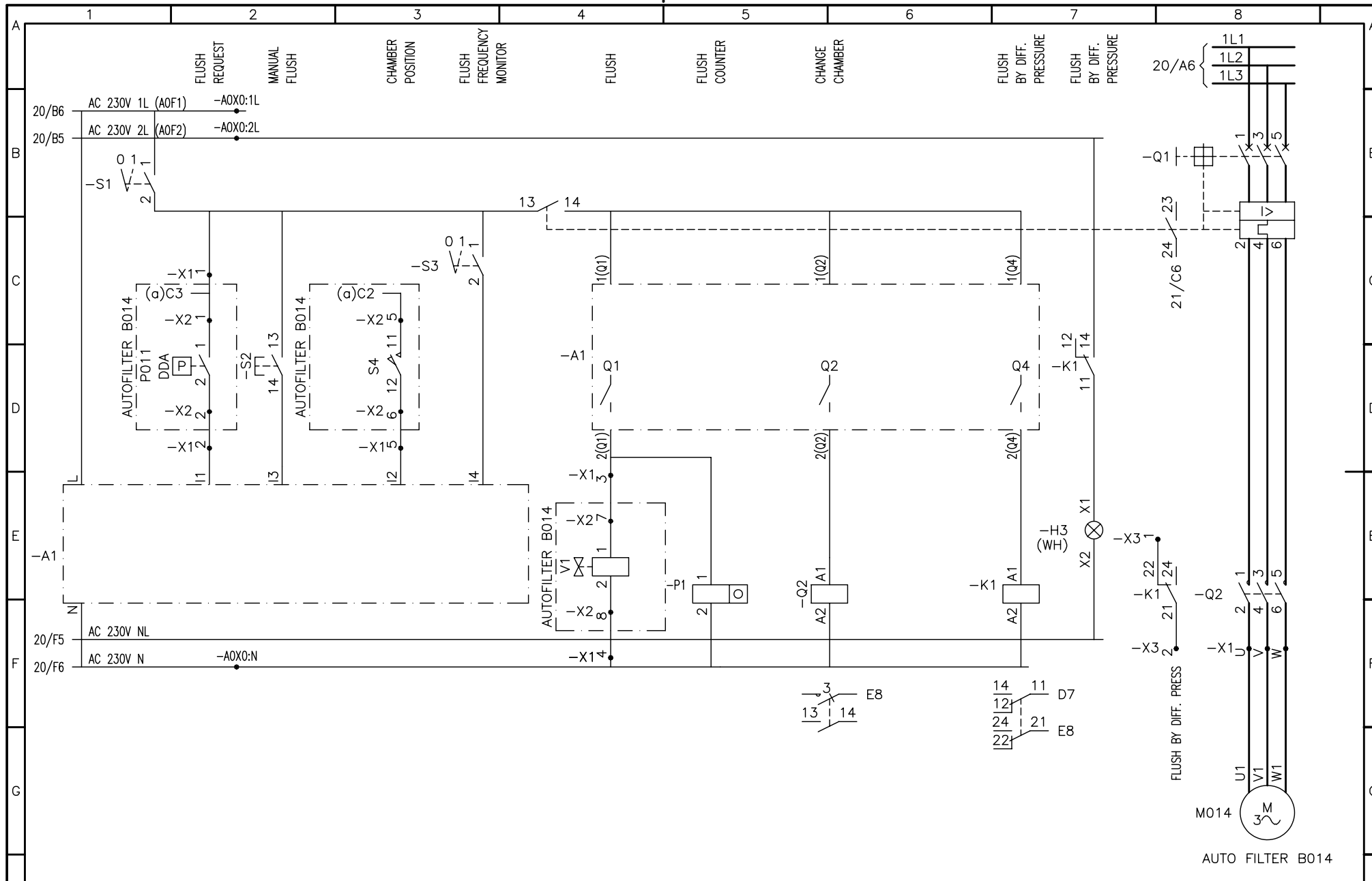

Product	AMB-M	CAD SCALE	
MADE	30.01.2007	KTa/Tammi	
CHKD.	30.01.2007	KTa/Tammi	
APPVD.	30.01.2007	RTu/Tuominen	

HUA HAI EQUIPMENT & ENG.
JNSY H2431/32/33
M/E

BOOSTER UNIT CONTROL PANEL
AUTO FILTER
Circuit Diagram

OBJECT	=E0-A14	DDC	Pg. Cnt.	number
Lang	GB	Suppl. Ident.	7563 5 7	SHEET 24
PROJECT #		IA3-DRAWING #		REV. B
			407584	

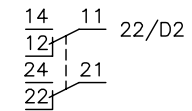
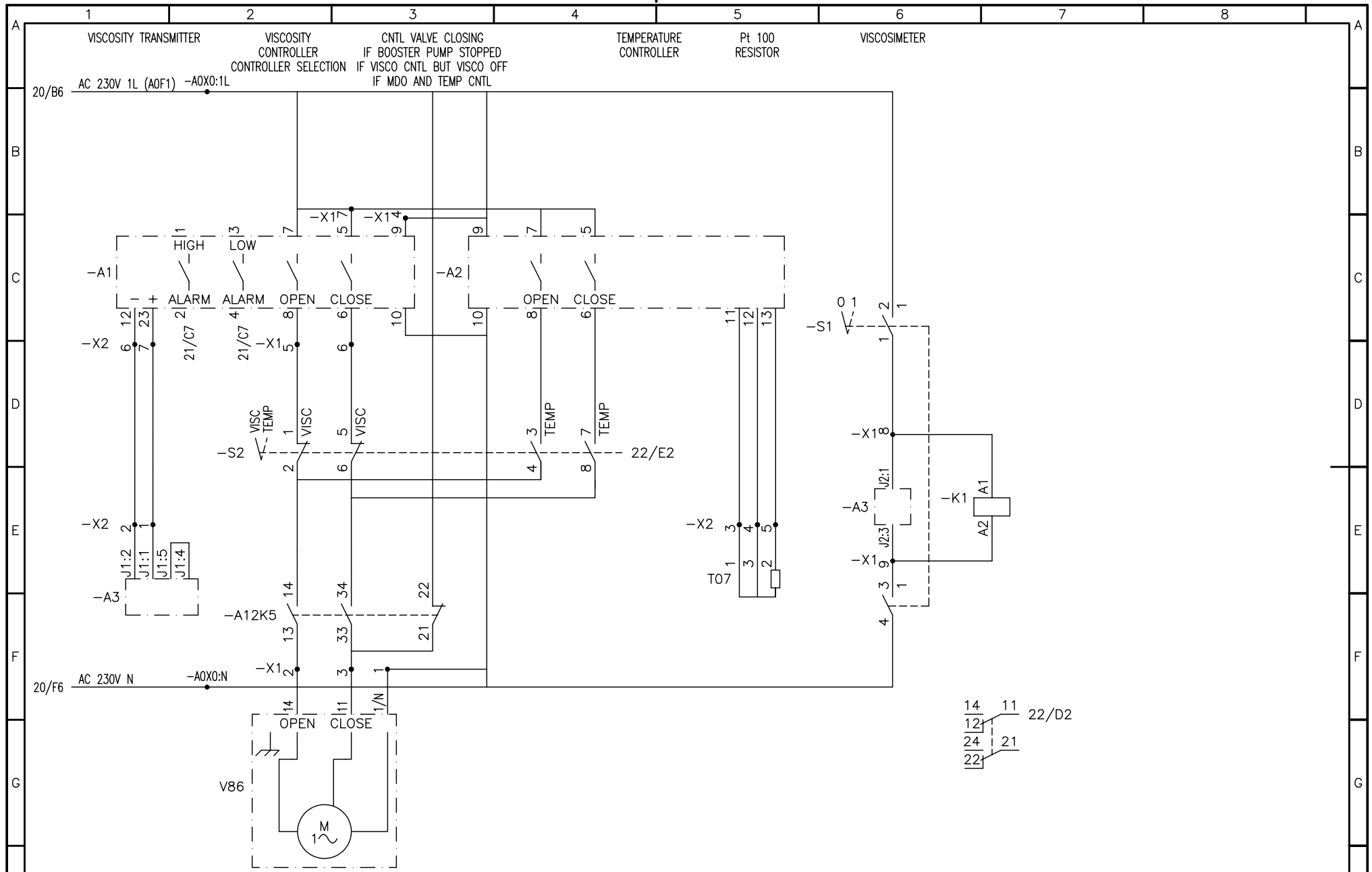

Product	AMB-M	SCALE	1:1
MADE	30.01.2007	KTa/Tammi	
CHKD.	30.01.2007	KTa/Tammi	
APPVD.	30.01.2007	RTu/Tuominen	

HUA HAI EQUIPMENT & ENG.
JNSY H2431/32/33
M/E

BOOSTER UNIT CONTROL PANEL
VISCOSIMETER, VISC CONTROL
Circuit Diagram

OBJECT	=E0-A16	DDC	Pg. Cnt.	number
Lang	GB	Suppl. Ident.	7563 5 7	SHEET 25 OF SHEETS 31
PROJECT #		A3-DRAWING #		REV. B
				407584

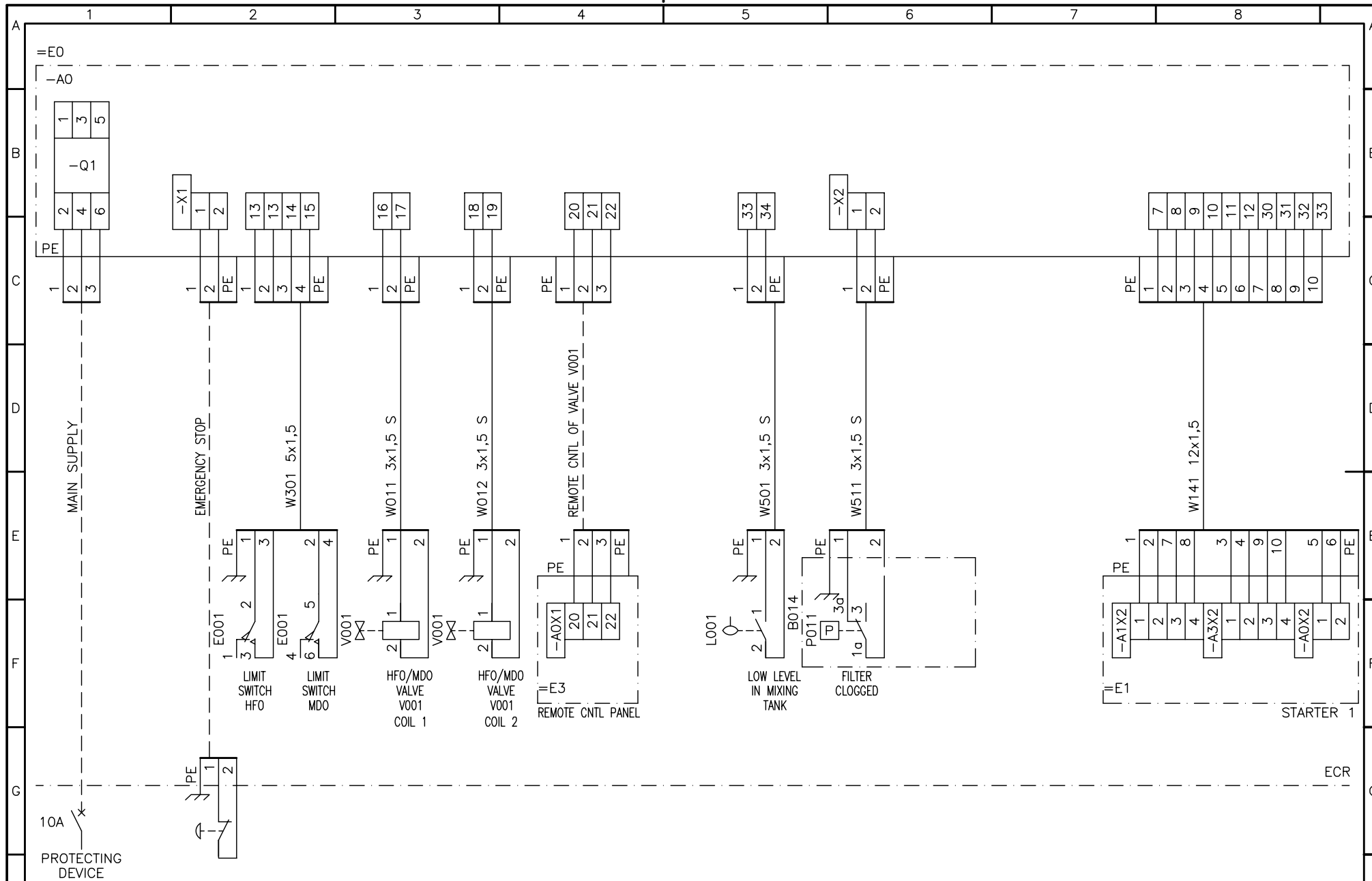

Product	AMB-M	CAD	SCALE
MADE	30.01.2007	KTa/Tammi	
CHKD.	30.01.2007	KTa/Tammi	
APPVD.	30.01.2007	RTu/Tuominen	

HUA HAI EQUIPMENT & ENG.
JNSY H2431/32/33
M/E

BOOSTER UNIT CONTROL PANEL
SUPPLY, ALARMS
Interconnection Diagram

OBJECT	=E0	DDC	Pg. Cnt.
Lang	GB	Suppl. Ident.	number
PROJECT #	7563	5	7
	A3-DRAWING #	407584	SHEET 26
			OF SHEETS 31
			REV. B

a Flow meter type changed 16042007 KTa

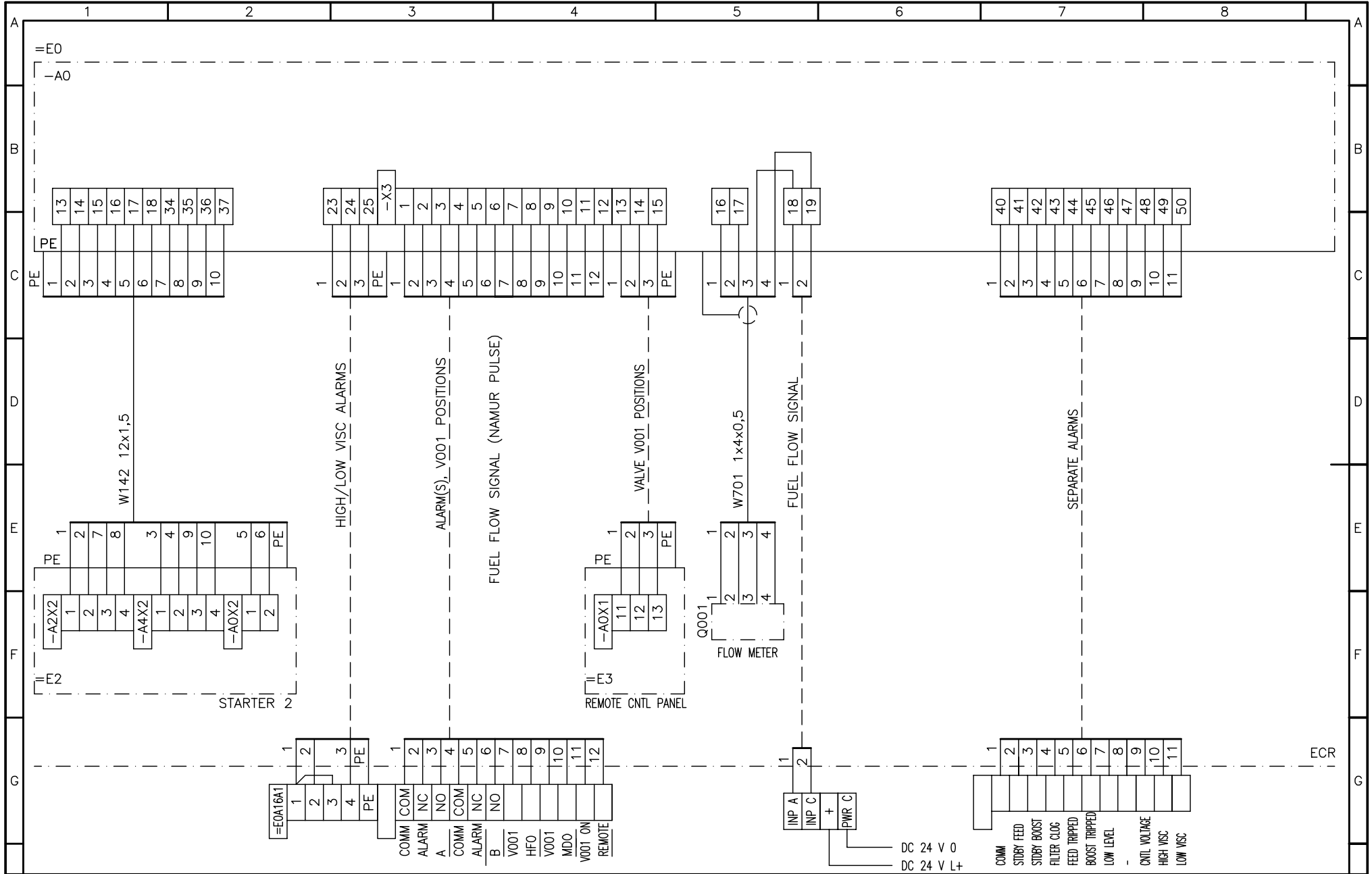

Product	AMB-M	SCALE	1:1
MADE	30.01.2007	KTa/Tammi	
CHKD.	30.01.2007	KTa/Tammi	
APPVD.	30.01.2007	RTu/Tuominen	

HUA HAI EQUIPMENT & ENG.
JNSY H2431/32/33
M/E

BOOSTER UNIT CONTROL PANEL
ALARMS, SIGNALS
Interconnection Diagram

OBJECT	=E0	DDC	Pg. Cnt.	number
Lang	GB	Suppl. Ident.	7563 5 7	SHEET 27
PROJECT #		A3-DRAWING #	407584	REV. B
				SHEETS 31

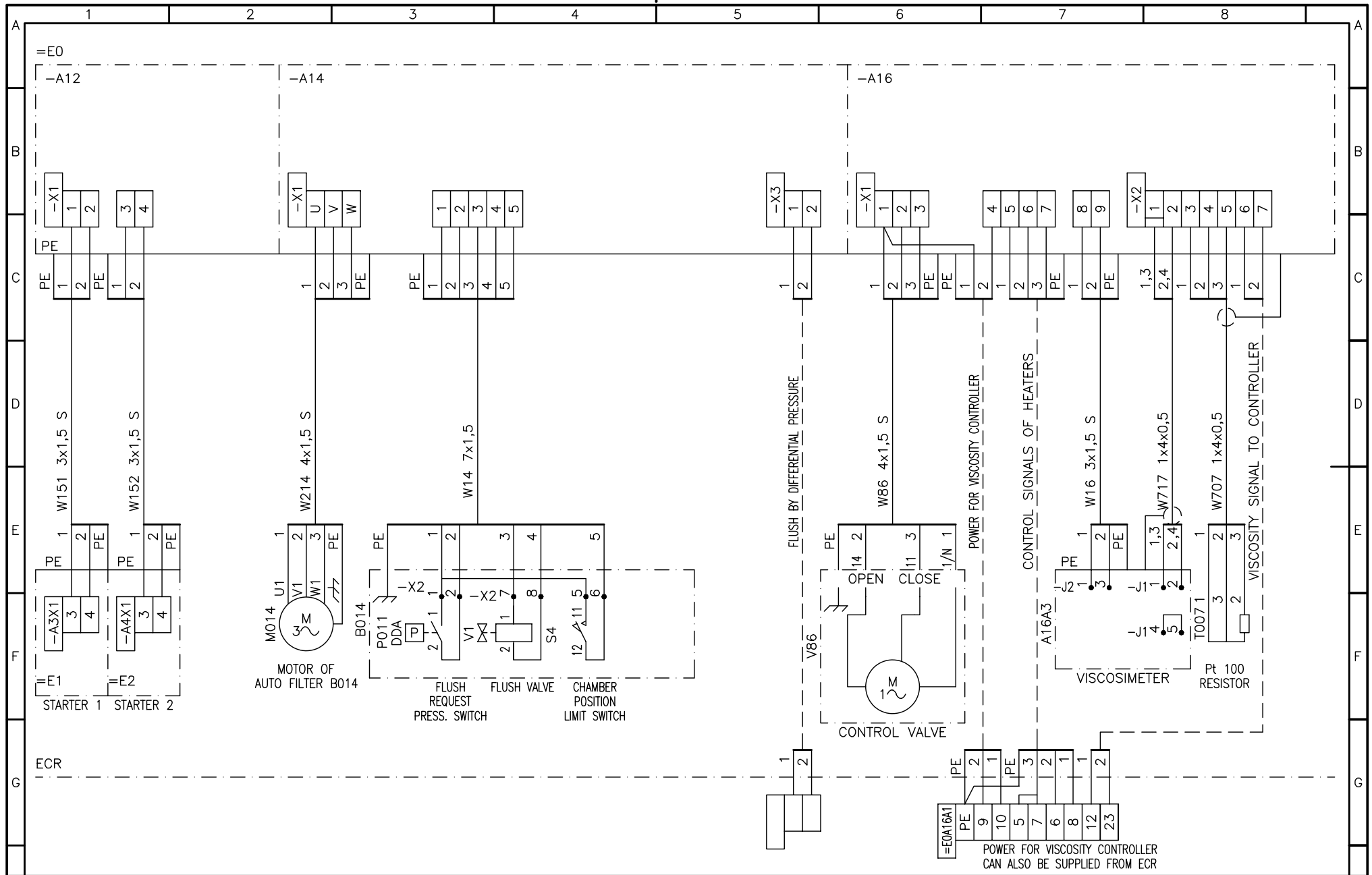

=E016A1
PE 9 10 5 7 6 8 12 23
POWER FOR VISCOSITY CONTROLLER
CAN ALSO BE SUPPLIED FROM ECR



Product	AMB-M	CAD SCALE
MADE	30.01.2007	KTa/Tammi
CHKD.	30.01.2007	KTa/Tammi
APPVD.	30.01.2007	RTu/Tuominen

HUA HAI EQUIPMENT & ENG.
JNSY H2431/32/33
M/E

BOOSTER UNIT CONTROL PANEL
AUTOMATIC FILTER & VISCOSIMETER
Interconnection Diagram

OBJECT	=E0 DDC	Pg. Cnt.	number
Lnng	GBI	7563	5
PROJECT #	1A3-DRAWING #	407584	
		SHEET	28
		OF SHEETS	31
		REV.	B

SHEET STEEL
SCANTLING 3mm
COLOR RAL 7035

LABELS FASTENED
ONLY WITH STICKERS
NO POP-RIVETS

LIST OF LABELS

id	pcs	text
1	1	M/E C-O VALVE
-	-	CONTROL PANEL
AOS1	1	HFO/MDO VALVE V001
-	-	HFO MDO
AOH2	1	VALVE V001 IN
-	-	HFO POSITION
AOH3	1	VALVE V001 IN
-	-	MDO POSITION

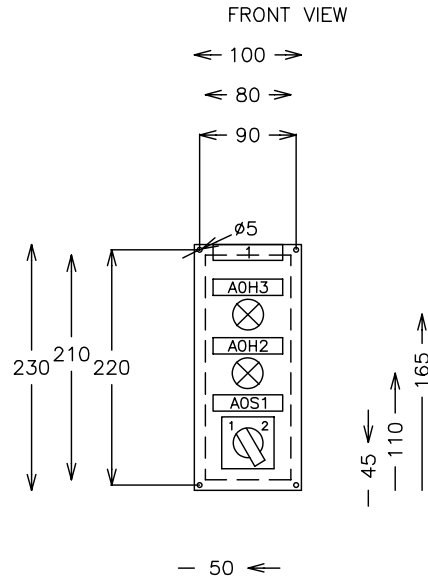

SIDE VIEW OF BACKSIDE

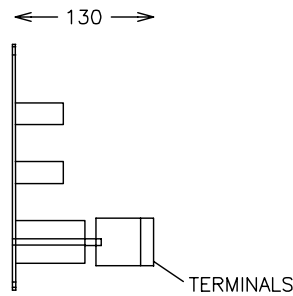

AC 230V 60Hz



AURAMARINE Ltd
FINLAND

Product	AMB-M	CAD	SCALE
MADE	30.01.2007	KTa/Tammi	
CHKD.	30.01.2007	KTa/Tammi	
APPVD.	30.01.2007	RTu/Tuominen	

HUA HAI EQUIPMENT & ENG.
JNSY H2431/32/33
M/E

BOOSTER UNIT REMOTE CNTL PANEL
-
Assembly Drawing

OBJECT	=E3DDC	Pg. Cnt.	number
LnG	GB	Suppl. Ident.	7563 5 7
PROJECT #	-	A3-DRAWING #	407584
		SHEET	29
		OF SHEETS	31
		REV.	B

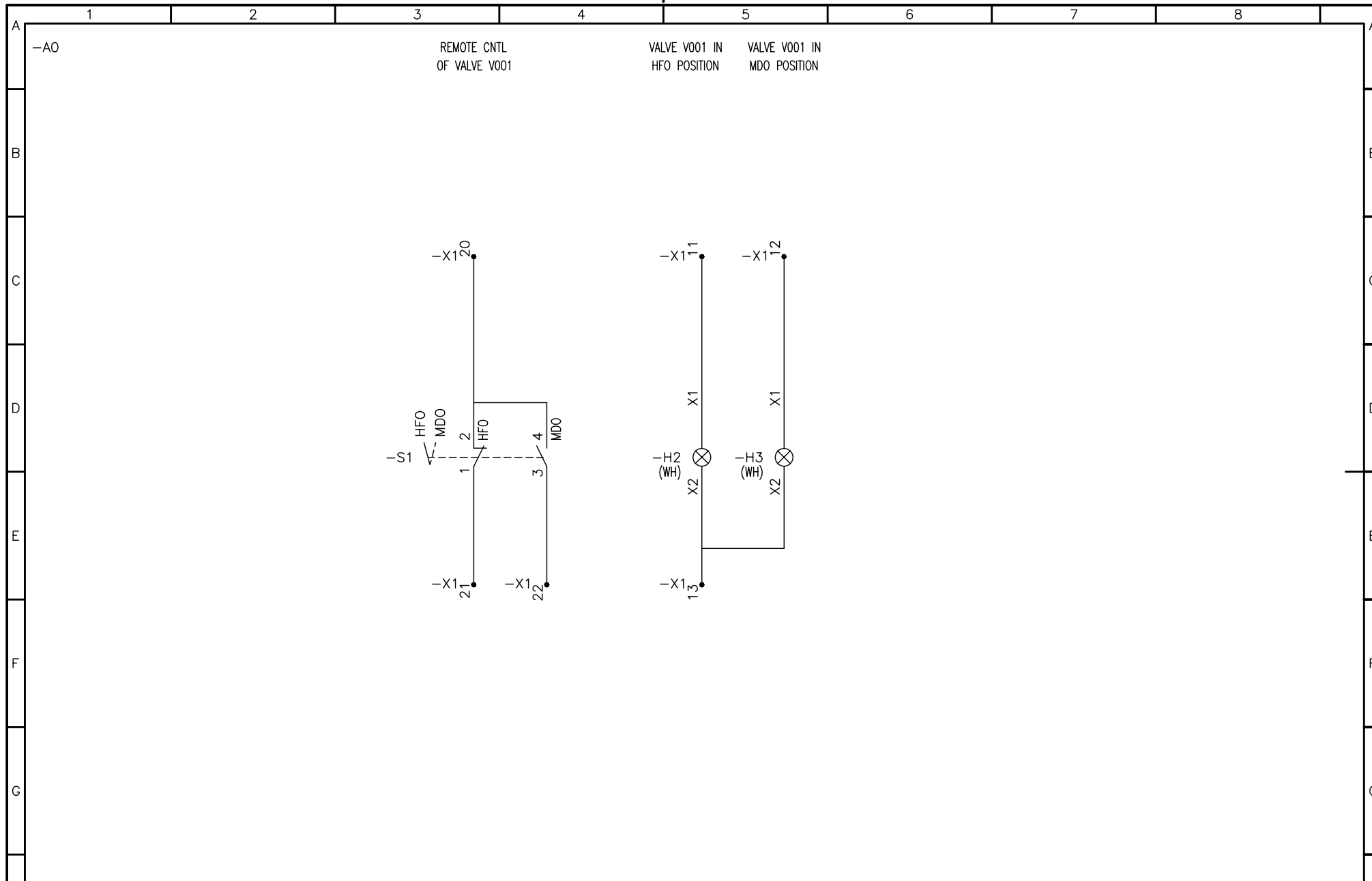

AURAMARINE Ltd
FINLAND

Product	AMB-M	CAD	SCALE
MADE	30.01.2007	KTa/Tammi	
CHKD.	30.01.2007	KTa/Tammi	
APPVD.	30.01.2007	RTu/Tuominen	

HUA HAI EQUIPMENT & ENG.
JNSY H2431/32/33
M/E

BOOSTER UNIT REMOTE CNTL PANEL
V001 CONTROL
Circuit Diagram

OBJECT	=E3-A0	DDC	Pg. Cnt. number
LnG	GB	Suppl. Ident.	7563 5 7
PROJECT #	-	SHEET	30
		OF SHEETS	31
		A3-DRAWING #	407584
		REV.	B

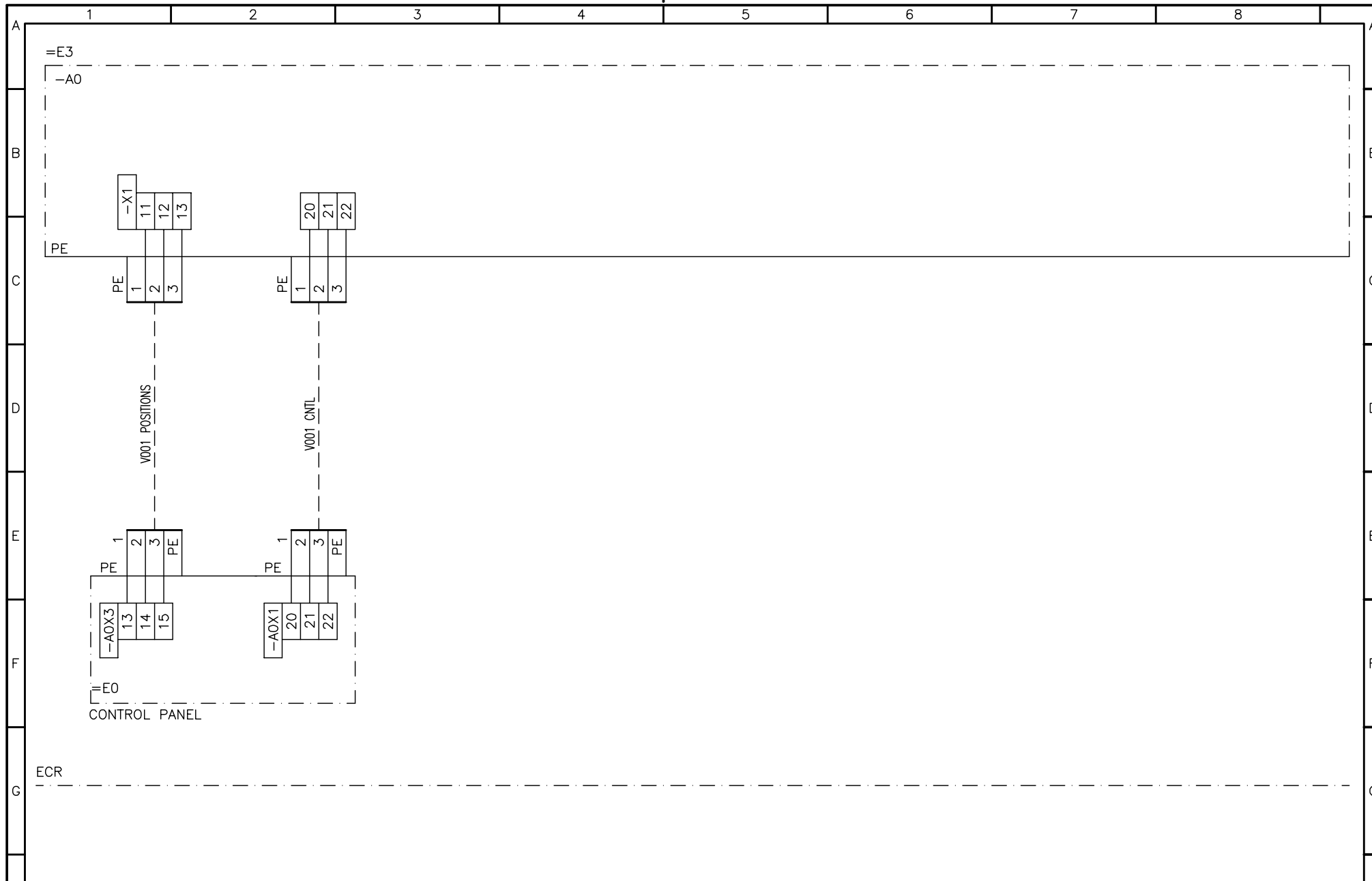

Product	AMB-M	SCALE	1:1
MADE	30.01.2007	KTa/Tammi	
CHKD.	30.01.2007	KTa/Tammi	
APPVD.	30.01.2007	RTu/Tuominen	

HUA HAI EQUIPMENT & ENG.
JNSY H2431/32/33
M/E

BOOSTER UNIT REMOTE CNTL PANEL
V001 CONTROL
Interconnection Diagram

OBJECT	=E3 DDC	Pg. Cnt.	number
LngrGB Ident.	7563 5 7	SHEET	3 1
PROJECT #	A3-DRAWING #	REV.	
-	407584	B	

ITEM	QTY	PART NO	DESCRIPTION	TYPE	MAKE	SETTING RANGE	RATED CURRENT
Starter 1	1	AF00509	Compact enclosure	AE 1039.500	Rittal		
	1	AF00534	Door stay for the AE range	SZ 2519.000	Rittal		
	0,04	AF00558	Adhesive backed foam tape	VCI-170 6,1mx(51x6,3mm)	Cortec		
A0Q1	1	AF00732	Switch disconnecter	OT 45 E3	ABB		
A0Q1	1	AF00740	Handle	OHY 2 AJ	ABB		
A0Q1	1	AF00735	Shaft	OXS5x160	ABB		
A0Q3	1	AF00340	Miniature circuit-breaker	5SX2 202-8	Siemens		2 A
A0T1	1	AF00632	Transformer	PE 250 VA	Trafomic		
A0F1,A0F2	2	AF00328	Miniature circuit-breaker	5SX2 102-7	Siemens		2 A
A0K1	1	AF00501	Time relay	MBS 2.430.012.02	Schiele		
A1Q1	1	AF00367	Auxiliary contact	140-A11	Allen-Bradley		
A1Q1	1	AF00360	Circuit breaker	140-MN-1600	Allen-Bradley	10...16 A	
A1Q2	1	AF00477	Contactora	100-C16KF10	Allen-Bradley		
A1Q2	1	AF00487	Auxiliary contact block	100-FA31	Allen-Bradley		
A1K1	1	AF00501	Time relay	MBS 2.430.012.02	Schiele		
A1S1	1	AF00714	Rotary cam switch	WAJ 545/8ZM/NS/AURA	Sontheimer		
A1K2	1	AF00443	Control relay	700-CF220KF	Allen-Bradley		
A1H1	1	AF00883	Indicating light	CL-523G	ABB		
A1H2	1	AF00882	Indicating light	CL-523R	ABB		
A1P1	1	AF00596	Self-powered time counter	H7ET-NFV-B	Omron Electronics		
A1P2	1	AF00594	A-meter	EQ 48 IP 54, 0-25/50 A with gasket	Deif		
A3Q1	1	AF00367	Auxiliary contact	140-A11	Allen-Bradley		
A3Q1	1	AF00362	Circuit breaker	140-MN-2500	Allen-Bradley	20...25 A	
A3Q2	1	AF00478	Contactora	100-C23KF10	Allen-Bradley		
A3Q2	1	AF00487	Auxiliary contact block	100-FA31	Allen-Bradley		
A3S1	1	AF00714	Rotary cam switch	WAJ 545/8ZM/NS/AURA	Sontheimer		
A3K2	1	AF00443	Control relay	700-CF220KF	Allen-Bradley		
A3H1	1	AF00883	Indicating light	CL-523G	ABB		
A3H2	1	AF00882	Indicating light	CL-523R	ABB		
A3P1	1	AF00596	Self-powered time counter	H7ET-NFV-B	Omron Electronics		
A3P2	1	AF00594	A-meter	EQ 48 IP 54, 0-25/50 A with gasket	Deif		
Starter 2	1	AF00509	Compact enclosure	AE 1039.500	Rittal		
	1	AF00534	Door stay for the AE range	SZ 2519.000	Rittal		
	0,04	AF00558	Adhesive backed foam tape	VCI-170 6,1mx(51x6,3mm)	Cortec		
A0Q1	1	AF00732	Switch disconnecter	OT 45 E3	ABB		
A0Q1	1	AF00740	Handle	OHY 2 AJ	ABB		
A0Q1	1	AF00735	Shaft	OXS5x160	ABB		
A0Q3	1	AF00340	Miniature circuit-breaker	5SX2 202-8	Siemens		2 A
A0T1	1	AF00632	Transformer	PE 250 VA	Trafomic		

Auramarine Ltd
Finland

EL. PART LIST

Product: AMB-M
Made: 07.11.2007 KTa/Tammi
Chkd: 07.11.2007 ARu/Rusanen
Appvd: 07.11.2007 RTu/Tuominen

Product id: 7563_5_7
Document id: PL407584B
Sheet 1 of 3

ITEM	QTY	PART NO	DESCRIPTION	TYPE	MAKE	SETTING RANGE	RATED CURRENT
A0F1,A0F2	2	AF00328	Miniature circuit-breaker	5SX2 102-7	Siemens		2 A
A0K1	1	AF00501	Time relay	MBS 2.430.012.02	Schiele		
A2Q1	1	AF00367	Auxiliary contact	140-A11	Allen-Bradley	10...16 A	
A2Q1	1	AF00360	Circuit breaker	140-MN-1600	Allen-Bradley		
A2Q2	1	AF00477	Contactora	100-C16KF10	Allen-Bradley		
A2Q2	1	AF00487	Auxiliary contact block	100-FA31	Allen-Bradley		
A2S1	1	AF00714	Rotary cam switch	WAJ 545/8ZM/NS/AURA	Sontheimer		
A2K2	1	AF00443	Control relay	700-CF220KF	Allen-Bradley		
A2H1	1	AF00883	Indicating light	CL-523G	ABB		
A2H2	1	AF00882	Indicating light	CL-523R	ABB		
A2P1	1	AF00596	Self-powered time counter	H7ET-NFV-B	Omron Electronics		
A2P2	1	AF00594	A-meter	EQ 48 IP 54, 0-25/50 A with gasket	Deif		
A4Q1	1	AF00367	Auxiliary contact	140-A11	Allen-Bradley		
A4Q1	1	AF00362	Circuit breaker	140-MN-2500	Allen-Bradley	20...25 A	
A4Q2	1	AF00478	Contactora	100-C23KF10	Allen-Bradley		
A4Q2	1	AF00487	Auxiliary contact block	100-FA31	Allen-Bradley		
A4K1	1	AF00501	Time relay	MBS 2.430.012.02	Schiele		
A4S1	1	AF00714	Rotary cam switch	WAJ 545/8ZM/NS/AURA	Sontheimer		
A4K2	1	AF00443	Control relay	700-CF220KF	Allen-Bradley		
A4H1	1	AF00883	Indicating light	CL-523G	ABB		
A4H2	1	AF00882	Indicating light	CL-523R	ABB		
A4P1	1	AF00596	Self-powered time counter	H7ET-NFV-B	Omron Electronics		
A4P2	1	AF00594	A-meter	EQ 48 IP 54, 0-25/50 A with gasket	Deif		
Cntl panel	1	AF00514	Compact enclosure	AE 1077.500	Rittal		
	1	AF00534	Door stay for the AE range	SZ 2519.000	Rittal		
	0,07	AF00558	Adhesive backed foam tape	VCI-170 6,1mx(51x6,3mm)	Cortec		
A0Q1	1	AF00732	Switch disconnectora	OT 45 E3	ABB		
A0Q1	1	AF00740	Handle	OHY 2 AJ	ABB		
A0Q1	1	AF00735	Shaft	OXS5x160	ABB		
A0Q3	1	AF00340	Miniature circuit-breaker	5SX2 202-8	Siemens		2 A
A0T1	1	AF00633	Transformer	PE 400 VA	Trafomic		
A0F1,A0F2	2	AF00328	Miniature circuit-breaker	5SX2 102-7	Siemens		2 A
A0T4	1	AF00644	1-Phase power supply	TC 115+115/24AC,24DC, 0,35/0,096A	Trafomic		
A0A1	1	AF00005	Alarm display unit	LLC-10, 24 V AC	IMSAB Ingenjörfirman M Sjöbris AB		
A0A1	1	AF00007	Relay circuit board	LLC RF	IMSAB Ingenjörfirman M Sjöbris AB		
A0K14	1	AF00441	Control relay	700-CF400KF	Allen-Bradley		
A0K5,A0K6	2	AF00441	Control relay	700-CF400KF	Allen-Bradley		
A0H2,A0H3	2	AF00880	Indicating light	CL-523W	ABB		
A0S4	1	AF00762	Rotary cam switch	ST34/8ZM/F302/NS/AURA	Sontheimer		

Auramarine Ltd
Finland

EL. PART LIST

Product: AMB-M
Made: 07.11.2007 KTa/Tammi
Chkd: 07.11.2007 ARu/Rusanen
Appvd: 07.11.2007 RTu/Tuominen

Product id: 7563_5_7
Document id: PL407584B
Sheet 2 of 3

ITEM	QTY	PART NO	DESCRIPTION	TYPE	MAKE	SETTING RANGE	RATED CURRENT
A14S1,-S3	2	AF00693	Rotary cam switch	A2/8ZM/F601/AURA	Sontheimer		
A14S2	1	AF00720	Non-Illuminated, Flush push button	800EP-F23LX10, Black	Allen-Bradley		
A14P1	1	AF00597	Self-powered total counter	H7EC-NFV-B, 230V	Omron Electronics		
A14A1	1	AF00689	Logic module LOGO! 230 RC	6ED1052-1FB00-0BA5	Siemens		
A14K1	1	AF00428	Miniature relay	40.52.8.230	Finder		
A14K1	1	AF00429	Screw terminal socket	95,75	Finder		
A14H3	1	AF00880	Indicating light	CL-523W	ABB		
A14Q2	1	AF00475	Contactora	100-C09KF10	Allen-Bradley		
A14Q1	1	AF00366	Auxiliary contact	140-A20	Allen-Bradley		
A14Q1	1	AF00352	Circuit breaker	140-MN-0040	Allen-Bradley	0,25...0,40 A	
A16A1_LOOSE	1	AF00679	Digital controller	E5EK-PRR2-500 AC100-240 (4-20 mA)	Omron Electronics		
A16A2	1	AF00681	Digital controller	E5EK-PRR2-500 AC100-240 (PT-100 fee	Omron Electronics		
A16S2	1	AF00709	Rotary cam switch	WS4/8ZM/F614/AURA	Sontheimer		
A16S1	1	AF00693	Rotary cam switch	A2/8ZM/F601/AURA	Sontheimer		
A12K5	1	AF00441	Control relay	700-CF400KF	Allen-Bradley		
A16K1	1	AF00428	Miniature relay	40.52.8.230	Finder		
A16K1	1	AF00429	Screw terminal socket	95,75	Finder		
A0S1	1	AF00708	Rotary cam switch	WS2/8ZM/F614/AURA	Sontheimer		
A0H2, A0H3	2	AF00618	Eco-pilot light, white	800EP-PM7DO	Allen-Bradley		
A0H2, A0H3	2	AF00617	Single chip LED	OD-W01 Ba9 R-230 BR	Oshino Lamps		



SECTION 4

4 Factory certificate

MAKER'S CERTIFICATE

This is to certify that AURAMARINE ASIA LD did inspection and test of:

Unit type: AMB-M-50 SS
Site: Auramarine Shanghai
Classification Society: GL

DRAWINGS

General arrangement: 407546
P&I diagram: 306648
Electric diagram: 407584B

VOLTAGE: 440V/60HZ/230VAC

PRESSURE TEST	DP bar	WP bar	TP bar	MEDIUM
Suction side	2	0	3	Oil
Feeder side	6	4	10	Oil
De-aeration vessel	6	4	10	Oil
Booster side	12	10	18	Oil
Steam side	10	7	15	Air/Water

The unit is surveyed in finished condition and tested min. 1.5xDP and found tight and in satisfactory condition.

GENERAL INSPECTION: The installation of mechanical/electrical equipment was considered satisfactory.

THE UNIT IS FINALLY STAMPED: "TP 15 bar"

Place: Shanghai, PRC

Tester:

Gu Cheng/AURAMARINE ASIA LTD



Date: 2008.02.22

AURAMARINE ASIA LTD.

Add: No. 13 LongYang Industrial Zone, No. 888
XinFeng Road, FengXian District, 201401 Shanghai, PRC
Tel: +86-21-6710 4305
FAX: +86-21-6710 4306

奥拉莫林(上海)船用设备有限公司

地址: 上海莘奉公路 888 号龙洋工业园区 13 号厂房
邮编: 201401
电话: +86-21-6710 4305
传真: +86-21-6710 4306

TEST REPORT

Manufacturer: AURAMARINE ASIA LTD

Tested and approved by: GU CHENG

Date: 2008.02.22



FUNCTIONAL TEST RESULT AND SET POINTS

Oil type: Fuchs Anticorit 5F

Pressure test:

Suction side: 3 bars
 Feeder side: 10 bars
 Booster side: 18 bars
 Steam side: 15 bars

DENOMINATION	FUNCT ION	SETTING RANGE	SET POINT
1.INSPECTION OF COMPONENT SUPPORT	Ok		
2.FEEDER PUMPS	Ok		
Motor protection	Ok	4.0-6.3A	4.75A
Stand-by press. Switch setting	Ok	1-10bar	3bar
Safety valves inside the pumps	Ok		10bar
3.PRESSURE CONTROL OVERFLOW VALVE	Ok	2-5Bar	4bar
4.DEAERATION SYSTEM	Ok		
Pilot air pressure			
Pressure keeping valve	Ok		
Low level	Ok		
Safety valve	Ok		10bar

DENOMINATION	FUNC TION	SETTIG RANGE	SET POINT
5.BOOSTER PUMPS	Ok		

AURAMARINE ASIA LTD.

Add: No. 13 LongYang Industrial Zone, No. 888
 13号厂房

XinFeng Road, FengXian District, 201401 Shanghai, PRC

Tel: +86-21-6710 4305

FAX: +86-21-6710 4306

奥拉莫林(上海)船用设备有限公司

地址: 上海莘奉公路 888 号龙洋工业园区

邮编: 201401

电话: +86-21-6710 4305

传真: +86-21-6710 4306

Motor protection	Ok	6.3-10.0A	8.3A
Stand-by press. Switch setting	Ok	1-10bar	6bar
Safety valves inside pumps	Ok		15bar
6.HEATERS SAFETY VALVES	Ok		16bar
7.TEMPERATURE CONTROL SYSTEM	Ok	0-200C	135C
Overtemp. alarm			
High temp. alarm			
Low temp. alarm			
Heating control valve	Ok		
Proportional band	Ok	0.1-999.9%	2.0%
Integral time	Ok	0-3999s	240s
Derivation time	Ok		40s
8.VISCOSITY CONTR.SYSTEM	Ok	0-50cSt	13cSt
Motor protection	Ok		
Low viscosity	Ok	From set point	-3cSt
High viscosity	Ok	From set point	+3cSt
Heating control valve	Ok		
Air regulating unit (if any)	Ok		
Proportional band	Ok	0.1-999.9%	10%
Integral time	Ok	0-3999s	240s
Derivation time			
9. CONTROL FOR EL.HEATER PRESSURE SWITCHES			
10.AUTOMATIC FILTER	Ok		
Motor protection			
Flushing time	Ok	0-10s	5 sec.
Flushing period	Ok	0-300min	120min
Diff. press. for flushing	Ok		0.6bar
Diff. press. for alarm	Ok		0.8bar

DENOMINATION	FUNC TION	SETTING RANGE	SET POINT
11.RUNNING LIGHTS	Ok		
12. OUTPUT SIGNAL	Ok		
marcs viscosity signal	Ok	4-20mA/0-50cSt	
am/l/h	Ok		
13.ALARMS TO CONTR.ROOM	Ok		

AURAMARINE ASIA LTD.

Add: No. 13 LongYang Industrial Zone, No. 888
13号厂房

XinFeng Road, FengXian District, 201401 Shanghai, PRC

Tel: +86-21-6710 4305

FAX: +86-21-6710 4306

奥拉莫林(上海)船用设备有限公司

地址: 上海莘奉公路 888 号龙洋工业园区

邮编: 201401

电话: +86-21-6710 4305

传真: +86-21-6710 4306

14.OTHER ALARMS	Ok		
High difference pressure	Ok		
Low pressure alarm	Ok		
Low instrument air pressure	Ok		
15.CONTINUITY OF PROTECTIVE BONDING CIRCUIT	Ok		
16.INSULATION RESISTANCE TEST	Ok		
17.VOLTAGE TEST	Ok	2500V	
18. MOTOR & EL.HEATER CURRENTS DO NOT EXCEED NORMAL VALUES	Ok		

Calibrated testing equipments:

- multi meter no: 82870249
- clamp meter: 76952904
- pressure gauges no: No1,2,3,4,5,6,7,8,9,10

Tester signature:

 Gu Cheng

Witnessed by classification society:

GL 
 Leaving time: 2008.02.22

Arrival time:

Date: 2008.02.22

AURAMARINE ASIA LTD.

Add: No. 13 LongYang Industrial Zone, No. 888
 13号厂房
 XinFeng Road, FengXian District, 201401 Shanghai, PRC
 Tel: +86-21-6710 4305
 FAX: +86-21-6710 4306

奥拉莫林(上海)船用设备有限公司

地址: 上海莘奉公路 888 号龙洋工业园区
 邮编: 201401
 电话: +86-21-6710 4305
 传真: +86-21-6710 4306



SECTION 6

6 Instruction manual

1	STORAGE, HANDLING AND INSTALLATION	5
1.1	Storage.....	5
1.2	Handling.....	5
1.3	Installation	5
2	SAFETY INSTRUCTIONS	7
3	WARNINGS AND INSTRUCTIONS	7
4	START-UP	8
5	SHUTDOWN.....	10
6	TROUBLE SHOOTING.....	11
7	MAIN SWITCH.....	12
8	ELECTRONIC TIMER, CT-S RANGE, TYPE 1SVR6300	13
8.1	Operating controls	13
8.2	Electrical diagram.....	14
8.3	Function diagrams.....	15
8.4	Factory settings by Auramarine Ltd.....	17
9	COUNTER, TYPE H7E	18
10	ALARM PANEL.....	20
10.1	Alarm panel for units with LRS classification.....	21
11	VISCOSITY AND TEMPERATURE CONTROLLERS E5EK	22
11.1	Operation	25
11.2	Access to parameters.....	26
11.3	Parameter settings of the viscosity controller A16A1	27
11.4	Parameter settings of the temperature controller A16A2.....	30
12	PRESSURE SWITCH MBC 5000, 5100	33
13	LEVEL LIMIT SWITCH LIQUIPHANT T FTL20	34
13.1	Instructions.....	34
14	FLOW METER, TYPE VZF.....	36
14.1	Display	37
14.2	Operation	38
14.2.1	Main menu	38
14.2.2	Information menu	40
14.2.3	Parameter menu	42
14.2.3.1	Parameter settings.....	44
14.2.3.2	Parameterising the display.....	48
14.2.3.3	Parameterising the flow sensor data.....	48
14.2.3.4	Parameterising the outputs	49
14.3	Error messages.....	53
14.4	Maintenance.....	53
15	VISCOSITY SENSOR, TYPE VISCOSENSE2	54
15.1	Operation	55
15.1.1	Initial start-up.....	55
15.1.2	Routine start-up.....	56
15.1.3	Shutdown on diesel oil	56
15.1.4	Shutdown on heavy fuel oil	56
15.2	Maintenance.....	56
15.2.1	Routine maintenance	56
15.2.2	Cleaning.....	57
15.2.2.1	Sensor assembly	57
15.2.3	Electrical connections	59
15.2.4	Trouble shooting and repair	60

15.2.5	Diagnostic information.....	60
15.2.6	General trouble shooting.....	62
15.2.7	PI setting errors (for additional viscosity controller).....	63
15.2.8	Parts list.....	64
16	HEAT EXCHANGER, TYPE MX.....	65
16.1	General Description.....	65
16.2	Operation.....	65
16.2.1	Commissioning.....	65
16.2.2	Initial start-up.....	65
16.2.3	Output.....	65
16.2.4	Conservation during shut down periods.....	66
16.3	Maintenance and cleaning.....	66
16.3.1	Regular cleaning periods.....	66
16.3.2	Cleaning of tubes.....	66
16.3.3	Heavy contamination.....	67
16.3.4	Checking the safety valves.....	67
16.3.5	Dismantling and reassembling of the tube section.....	67
16.4	Spare parts.....	68
17	AC ELECTRIC INDUCTION MOTORS.....	69
17.1	Maintenance.....	69
17.1.1	Periodic maintenance.....	69
17.1.2	Wound rotor.....	70
17.1.3	Hazardous area motors.....	70
17.2	Replacing non-drive end bearing.....	70
17.2.1	Bearing removal.....	70
17.2.2	Bearing replacement.....	71
17.3	Spare parts.....	72
18	SCREW PUMP, TYPE ACG GEN 8.....	75
18.1	Start-up.....	77
18.1.1	Direction of rotation.....	77
18.1.2	Differential pressure.....	77
18.2	Maintenance.....	78
18.2.1	Inspection of rotors.....	78
18.2.2	Inspection of the magnetic coupling.....	79
18.2.3	Common aspects whit magnetic couplings.....	79
18.2.4	Dismantling.....	80
18.2.5	Reassembly.....	85
18.3	Spare parts.....	92
18.3.1	Spare part and tool kits.....	93
18.4	Trouble shooting.....	94
19	BALL VALVE, TYPES N2, N8 AND N9.....	97
19.1	Operation.....	97
19.1.1	Manual operation.....	97
19.1.2	Automated operation.....	97
19.2	Maintenance.....	97
19.2.1	Steam leakage.....	98
19.2.2	Body seals leakage.....	98
19.2.3	In line or seats leakage.....	98
19.3	Valve disassembly to inspect and/or replace body seals, seats, packing and ball.....	98
19.4	Inspection and replacement.....	99
19.5	Re-assembly.....	99

19.5.1	Steam re-assembly	99
19.5.2	Ball, seats and seals re-assembly, types N8 and N9	99
19.5.3	Ball, seats and seals re-assembly, type N2	100
19.6	Testing	100
19.7	Automated ball valves	100
19.8	Tightness values for handle nut 2A-2B and body bolts 16, types N8 and N9	101
19.9	Tightness values for handle nut 2A-2B and body bolts 16, type N2	101
19.10	Storage	101
19.11	Spare parts	102
20	CONTROL VALVE, TYPES BR440-446	103
20.1	Maintenance.....	103
20.1.1	Packings with PTFE V-ring unit.....	104
20.1.2	Stuffing box packings	105
20.1.3	Bellow Seal	106
20.1.4	Replacing the Plug, Spindle and Seating	107
20.2	Troubleshooting.....	109
21	THRUST ACTUATOR, TYPE PREMIO	110
21.1	Manual operation.....	111
21.1.1	2.2 - 5 Kn	111
21.1.2	12 - 15 Kn	112
21.2	Settings	113
21.2.1	Torque and travel switches -standard feature	113
21.2.2	Connection boards PA or NA (only 2.2- 5 kN).....	114
21.2.3	Potentiometers	114
21.3	Putting the actuator into operation	114
21.4	Diagram.....	115
21.5	Maintenance.....	116
21.6	Dismantlement of thrust actuator	116
21.7	Troubleshooting.....	117
21.7.1	Troubleshooting table.....	118
22	VALVE, SERIES 776000	119
23	SWITCHBOX, SERIES W AUTOMAX	120
23.1	Adjusting limit switches	120
24	AUTOMATIC VENT VALVE, G8070, F8071	122
25	PRESSURE RELIEF VALVE, TYPE RSB	123
25.1	Operation	123
25.2	Commissioning.....	123
25.3	Adjustment	124
25.4	Trouble Shooting	124
26	STOP VALVE, TYPES FIG 215 AND FIG-216	128
27	FILTER, MODEL F08.....	129
27.1	Maintenance.....	130
27.1.1	To clean or replace bowl assembly	130
27.1.2	To replace filter element.....	130
28	SINGLE FILTER 1.03.2	131
28.1	Commissioning.....	131
28.1.1	Pressure filters (>01.1 bar pressure in the filter)	131
28.1.2	Suction filters (< 0.1 bar pressure in the filter).....	132
28.2	Maintenance.....	132
28.2.1	Cleaning the multi-mantle filter elements	133
28.3	Cover securing device for double filters	134

28.3.1	Operating	134
28.4	Spare parts.....	140
29	FILTER, TYPE 6.61.	143
29.1	General	143
29.2	Start-up	145
29.3	Manual operation of the automatic filter	146
29.4	Control of automatic filter, type 6.61	147
29.4.1	Chamber fill up time change.....	148
29.4.2	Flush period change.....	149
29.4.3	Flush time change.....	149
29.4.4	Parameter settings.....	149
29.4.5	Set clock is selected to set time and date.	150
29.5	Maintenance.....	151
29.5.1	Servicing tools.....	152
29.6	Candle element cleaning agent "BOLL CLEAN 2000"	153
29.6.1	Mesh contaminated with heavy oil:	153
29.6.2	Manual cleaning of the candle filter elements	154
29.7	Spare parts.....	156
29.7.1	Type 6.61, GR.10 DN100 25/34/50 MICR.....	156
29.7.2	Type 6.61, GR.10 DN100 10 MICR.....	158
29.7.3	Type 6.61, GR.15 DN150 10 MICR.....	160
29.7.4	Type 6.61, GR.15 DN150 25/34/50 MICR.....	163
30	PRESSURE VESSELS	168
31	HOW TO ORDER SPARE PARTS	169

1 STORAGE, HANDLING AND INSTALLATION

1.1 Storage



The unit is to be protected from rain, snow and dirt. In order to avoid condensation, it is recommended to avoid temperature variation.

Storage temperature -10 to +60°C
Ambient humidity max. 85%

1.2 Handling

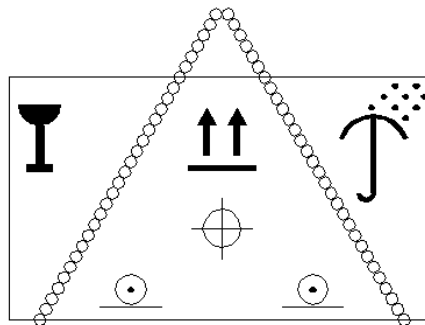

packed unit

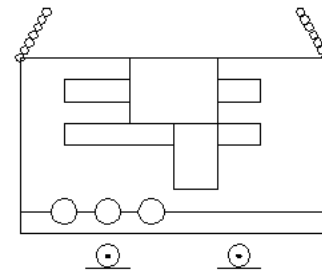

unpacked unit



Unit is handled from lift hangers or with forklift truck. Used lifting device is to have adequate lifting capacity and break resistance, and it is prohibited to be under lifted load.

1.3 Installation

Package material is wood and plastic. Package materials are to be disposed or recycled according to local law.

Before final installation and fastening of the unit, the following is to be taken into account:

Visual inspection is recommended in order to see possible damages caused by transport or moving to the installation place.

Needed service space can be seen in the general arrangement drawing.

Installation place is to be as vibration free as possible.

Installation place must have adequate ventilation in order to prevent explosion danger.

The unit must be fastened with bolts or by welding, see general arrangement drawing. Additional bracing of booster unit must be done if vibration is detected.

Plugs of pipe connections are to be removed before installing pipes to fuel oil unit.

It is recommended that all HFO pipelines connected to fuel oil units are insulated and trace heated.

Pipeline connections can be seen in the general arrangement drawing.

Electrical connections can be seen in the interconnection pages of the electric drawings.

Protective bonding to be executed according to the standards of the installation place.

Before start-up, activate the gas generator of the SealGuard, if installed.

2 SAFETY INSTRUCTIONS



1. Read the instruction manual for the unit.
2. Wear protective clothing, ear defenders and eye protection. Danger of burning lesion. Beware of hot surfaces, hot oil and noise.
3. Switch voltage off before maintenance occurs.
4. Electrical work must be carried out according to the standards by authorised persons.
5. Close shut off valves from both sides and depressurise the equipment and pipes before any maintenance action. To prevent danger of hot liquid/steam spray.
6. Use crane to lift heavy parts during maintenance and ensure that parts removed come off in a controlled manner.
7. After maintenance, ensure that all parts are assembled correctly.
8. Ensure that the safety instructions for all cleaners, oils and paints are available.
9. Keep the environment of the unit clean. "Slippery floors may cause injury."
10. Smoking is not allowed in the immediate surroundings of fuel oil units.
11. Unwanted equipment and chemicals should be disposed of in a safe manner and according to local laws and regulations.

3 WARNINGS AND INSTRUCTIONS



1. Pumps start automatically after power failure.
2. Run only one pump and heater simultaneously. Switch the other pump to stand-by.
3. Ensure fuel oil flow through intended heater.
4. Turn trace heating on if unit is stopped during HFO running.
5. Keep the feeder pressure setting at least at 3 bar.
6. Do not heat LFO/MDO above 50°C.
7. Do not adjust feeder/booster pressure from pumps.
8. Do not run pumps dry.
9. Electric heaters and steam/thermal oil control valve are interlocked with booster pumps viscometer and HFO/LFO, MDO three way valve.
10. It is recommended that all HFO pipelines connected to fuel oil units are insulated and trace heated.
11. In case of no instrument air by pass filter is to be used.
12. Make sure that the operating pressure of the pressure vessel does not exceed the design pressure, that the temperature of the pressure vessel's contents does not exceed the maximum allowed operating temperature and that- the connections do not leak.

4 START-UP

Before start-up, activate the gas generator of the SealGuard, if installed.

1. Switch main switches and all control switches of the unit to off position.
2. Switch instrument air on to fuel oil units.
3. Ensure LFO/MDO flow to feeder/booster unit. Suction pressure gauge of the unit should indicate pressure (>0 bar). Open the equipment valves of feeder/booster unit and close by-pass valves.
4. Check that valves of the engine(s) are in right position.
5. Ensure that fuel oil from engine(s) flows to booster unit's mixing tank.
6. Ensure that all miniature circuit breakers, motor circuit breakers and moulded case circuit breakers are switched on in local control panel(s) of the fuel oil unit(s).
7. Switch main switch to on position.
8. After resetting the alarm panel, the following alarms should be on. Low outlet pressure (if installed), low level in mixing tank, low viscosity (if not blocked with signal from HFO/LFO, MDO valve).
9. Start feeder pump and check rotation direction.
10. To fill fuel oil unit and pipelines to and from engine(s) with LFO/MDO will take from two to ten minutes.
11. Low level in mixing tank alarm will go off after tank is filled. In case of manual deaeration open the deaeration valve until the low level alarm goes off.
12. Pressure in fuel oil unit and engine(s) should rise to range from three to five bar. If not, check positions of valves.
13. Change running feeder pump. Check rotation direction. Use always one pump as running and one pump as stand-by. Change running pump periodically in order to run pumps equally.
14. Check that steam/thermal oil valves are closed and electric heaters are off.
15. Start booster pump. Check rotation direction. Pressure in pipelines after booster pumps should rise to range from six to nine bar (setting in engine's equipment). Low outlet pressure alarm goes out (if installed).
16. Change running booster pump. Check rotation direction. Use always one pump as running and one pump as stand-by. Change running pump periodically in order to run pumps equally.
17. Start viscometer. Viscosity of LFO/MDO is in range from three to eight mPas.
18. Low viscosity alarm is on (if not blocked with signal from HFO/LFO, MDO valve).
19. Start auto filter.
20. Start engine.
21. Change fuel oil from LFO/MDO to HFO.
22. Ensure that needed trace heating is on.

23. If there is HFO/LFO, MDO valve in feeder/booster unit turn it to HFO position.
24. Open steam/thermal oil valves or switch electric heater on by control switch at local control panel.
25. Ensure the operation of viscosity/temperature controller if they are not installed to local control panel by Auramarine Ltd.
 - a) Choose controller by control switch at local control panel.
 - b) Set setpoint above process value. Control valve should open or stages of electric heater should increase power.
 - c) Set setpoint below process value. Control valve should close or stages of electric heater should decrease power.
 - d) In case of malfunction, check wiring.
 - e) Set setpoint to normal and viscosity control on.
26. Low viscosity alarm goes out after engine has consumed all LFO/MDO from circulation.
27. After engine has run from 1,5 to 2 hours with HFO, check all pipe connections, and in case of leakage, tighten the pipe connection.

Attention

Fuel oil viscosity can be regulated by viscosity or by temperature.

Recommended way is to use viscosity control, because it keeps the injection viscosity constant regardless of the fuel oil quality by regulating temperature.

As back-up fuel oil viscosity can be controlled by temperature.

Selection by above mentioned controls is done by control switch at local control panel and valves of heaters and valves of steam/thermal oil lines.

5 SHUTDOWN

1. Circulate the fuel oil through heater at least ten minutes after turning heating off in order to cool the heater down.
2. Turn the trace heating on if there is HFO in pipe system of the fuel oil unit.

6 TROUBLE SHOOTING

Problem	Check points / actions
Stand-by pump starts.	<p>Open suction valves if they are closed. Suction pressure should be above -0,5 bar, if below clean the suction strainers. Setpoint of pressure control valve should be 4-5 bar. The by-pass valve of the pressure control valve should be closed. Check rotation direction of pumps. Check pressure control valve setting at engine(s) equipment. Ensure that fuel oil from engine(s) flows to booster unit's mixing tank. The shut of valve of the pressure switch should be open. The deaerating valves of the heaters and mixing tank should be closed. Check the operation of the auto filter and by-pass filter of the auto filter. Check the operation of the pressure switch and the alarm panel Check the settings and cleanness of the internal over flow valves of the pumps. Check that the delay of the stand-by pump start is sufficient.</p>
Pressure too high at pump outlet.	<p>Check positions of valves Run only one feeder and one booster pump simultaneously. Setpoint of pressure control valve at engine(s) equipment may be too high. Clean the heaters. Check the operation of the auto filter and by-pass filter of the auto filter.</p>
Heating is not working.	<p>Check the positions of the steam/thermal oil valves. Moulded case circuit breakers of the electric heaters should be on. Safety thermostats of the electric heaters may be tripped. Control switch of the electric heater should be on. Viscometer is not running. The by-pass valve of the heater should be closed. HFO/MDO, LFO valve should be in HFO position.</p>
Viscometer is not working.	<p>Check positions of control switches at local control panel. Viscometer should be on and viscosity control should be selected. Check wiring of the controller and viscosity measuring loop. By-pass valve of the viscometer should be closed. Check the selector switch of density at viscometer.</p>
Low level in mixing tank.	<p>Feeder pump is not running. Fuel from engine does not flow to the mixing tank of booster unit.</p>
Flow meter is not working.	<p>Check the cleanness of the flowmeter filter and rotor. The valves of the flow meter are closed. The by-pass valve of the flow meter is dirty. Check wiring and settings if there are out going signals.</p>
Safety valve is open.	<p>Working pressure is above the setpoints of the safety valves. Setpoint at mixing tank is 10 bar and at heaters 15 bar. Valves after heaters should be open. Safety valve is damaged.</p>

7 MAIN SWITCH

Door of the control panel can be opened with main switch on by pressing with a pin to hole shown below.



8 ELECTRONIC TIMER, CT-S RANGE, TYPE 1SVR6300



8.1 Operating controls

- Adjustment of the time range by selecting the max. value:

Range	Max. value
0.15 - 3 s	>> 3 s yellow
1.5 - 30 s	>> 30 s dial
15 - 300 s	>> 300 s
1.5 - 30 min	>> 30 min
15 - 300 min	>> 300 min
1.5 - 30 h	>> 30 h
15 - 300 h	>> 300 h
0.05 - 1 s	>> 1 s white
0.5 - 10 s	>> 10 s dial
5 - 100 s	>> 100 s
0.5 - 10 min	>> 10 min

- Direct reading scale to set the time value within the chosen range
- Function / Selection of the function on CT-MFS and CT-MBS
Functions: see III
- Setting of the 2nd c/o contact as an instantaneous contact
Position Inst. "I": Instantaneous contact
- Status display with LEDs:

U/T: green LED Status indication of control supply voltage and timing

 Control supply voltage applied
 Time delay is running

R: yellow LED - Status indication of output relay

 energized

R1/R2: yellow LED - Status indication of output relay 1/2

 energized

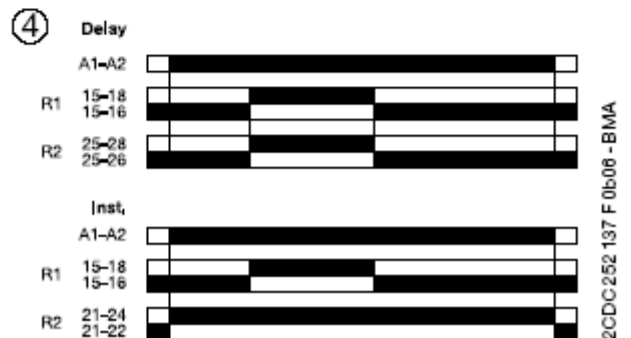
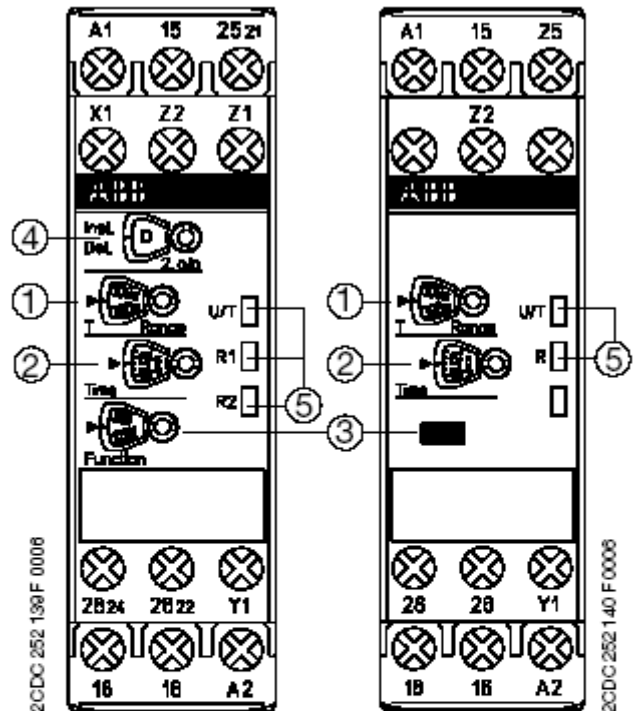

8.2 Electrical diagram

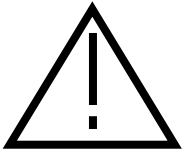

For the rated control supply voltage and the circuit diagram, see label at the side of the unit

A1-A2
Y1-Z2
X1-Z2

Control supply voltage U_s
Control input to start timing
Control input to pause timing / accumulative function (see diagram under V)

Z1-Z2

Remote potentiometer connection for the fine adjustment of the time delay. When an external potentiometer is connected, the internal, front-face potentiometer is disabled.

15-16/18

1st c/o contact

25-26/28

2nd c/o contact

(21)-(22)/(24)

2nd c/o contact, set as instantaneous contact

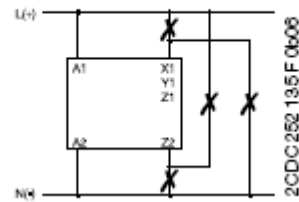
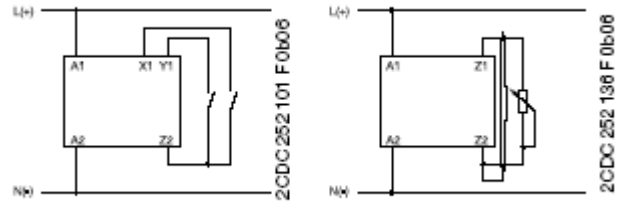

8.3 Function diagrams

CT-MBS and CT-MFS

1.  ON-delay
t adjusted time delay

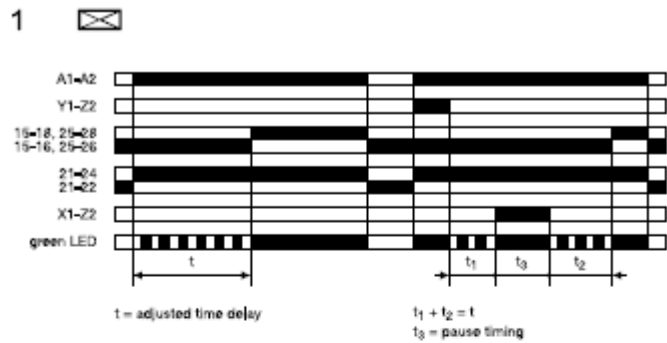

2CDC-252 018 F 0206 - BMA

2.  Impulse-ON
t adjusted pulse time

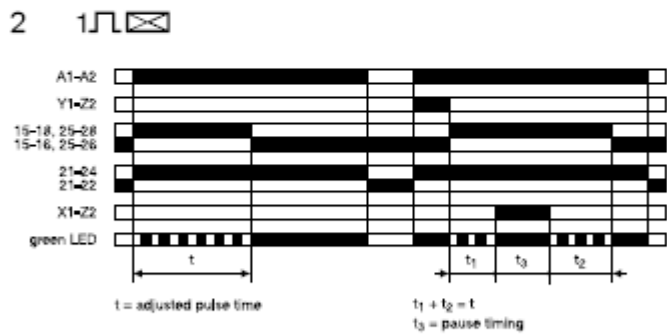

2CDC-252 025 F 0206 - BMA

3.  Flasher with reset, starting with ON
t adjusted flashing time

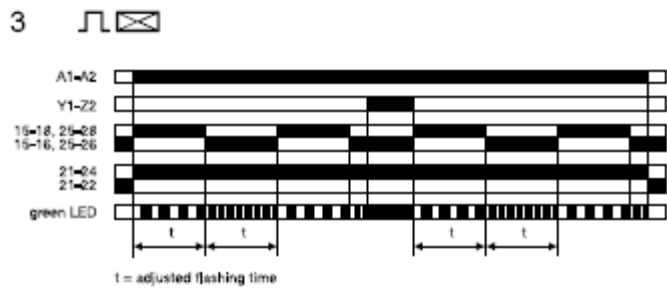

2CDC-252 031 F 0206 - BMA

4.  Flasher with reset, starting with OFF
t adjusted flashing time

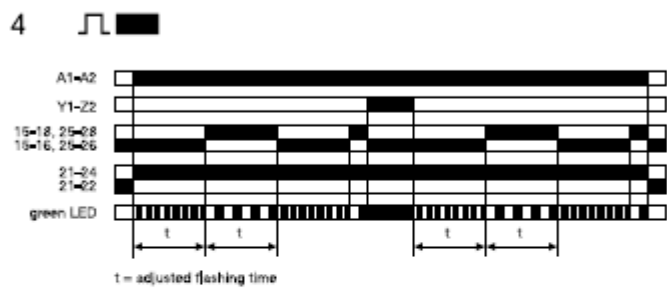

2CDC-252 032 F 0206 - BMA

5.  OFF-delay with auxiliary voltage
t adjusted time delay

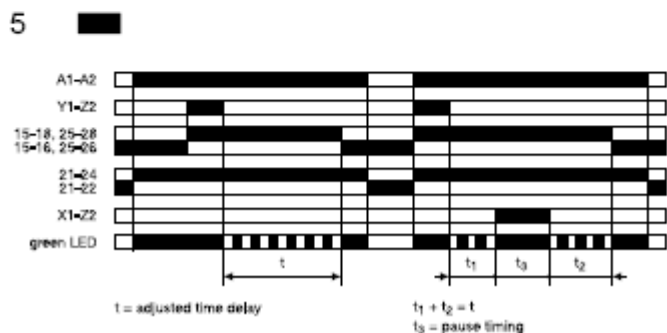

2CDC-252 019 F 0206 - BMA

6.  Impulse-OFF with auxiliary voltage
t adjusted pulse time

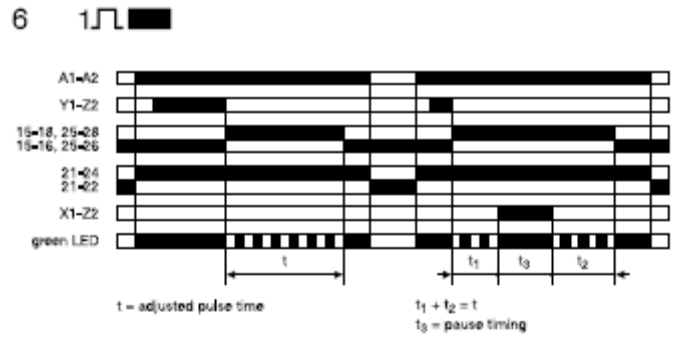

2C/DC 252 026 F 0206 - BMA

7.  Star-delta change-over with impulse function
t1 adjusted starting time
t2 fixed transition time of 50 ms

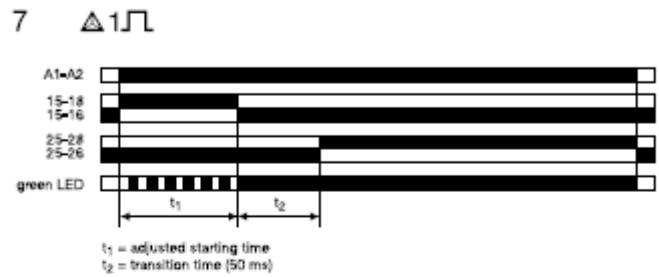

2C/DC 252 030 F 0206 - BMA

8.  ON-delay and OFF-delay, symmetrical
t1 adjusted ON-delay
t2 adjusted OFF-delay

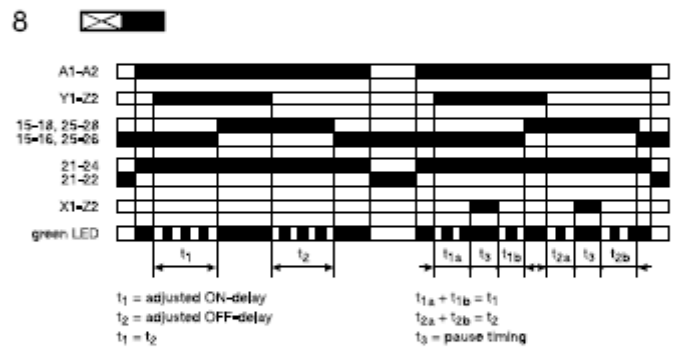

2C/DC 252 022 F 0206 - BMA

9.  Pulse former
t adjusted pulse time

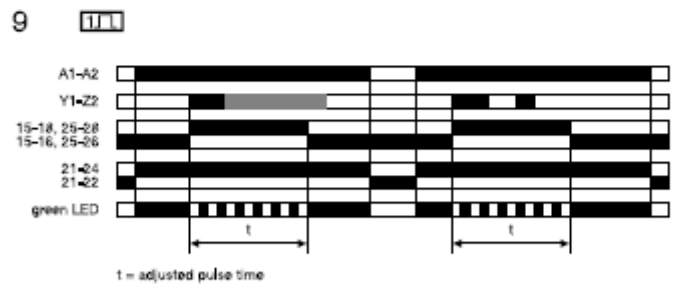

2C/DC 252 034 F 0206 - BMA

10.  ON/OFF-Function
ON-Function - time sector \neq 300 h
OFF-Function - time sector = 300 h

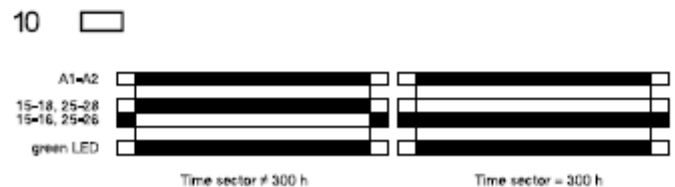

2C/DC 252 044 F 0206 - BMA

CT-AHS

5. OFF-delay with auxiliary voltage
t adjusted time delay

CT-ARS

11. OFF-delay without auxiliary voltage
t adjusted time delay

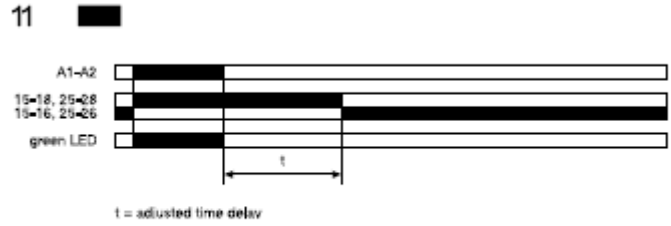

2CDC 252 02 1 F 0206 - BMA

8.4 Factory settings by Auramarine Ltd.

Duty	Mode	Setting
delay of stand-by start (delay on release)	5	3 seconds

5

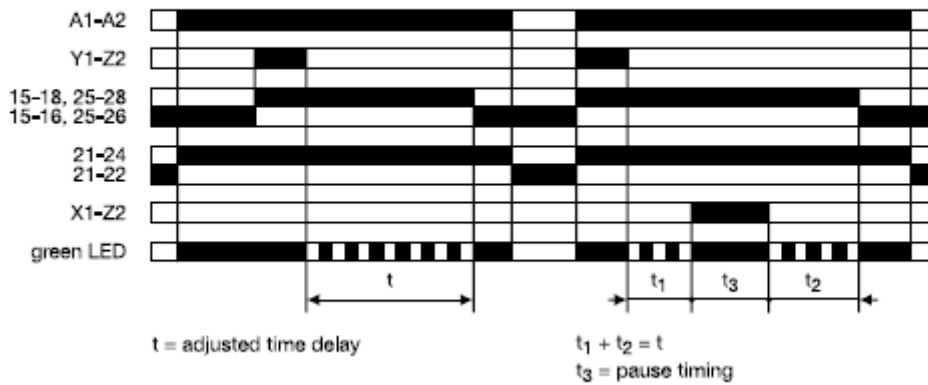

2CDC 252 019 F 0206 - BMA

9 COUNTER, TYPE H7E



The product has a built-in lithium battery. Do not short-circuit the + and - terminals, charge, disassemble, deform, or expose the battery to fire. The battery may explode (break), catch fire, or cause liquid leakage.

Do not use any battery other than the specified one (Y92S-36). Using another battery may cause liquid leakage or breakage, resulting in malfunction or injury.

If a voltage other than the rated one is applied, internal elements may be damaged.

Do not use the Counter in locations subject to direct sunlight, subject to corrosive gases or subject to dust.

Nomenclature

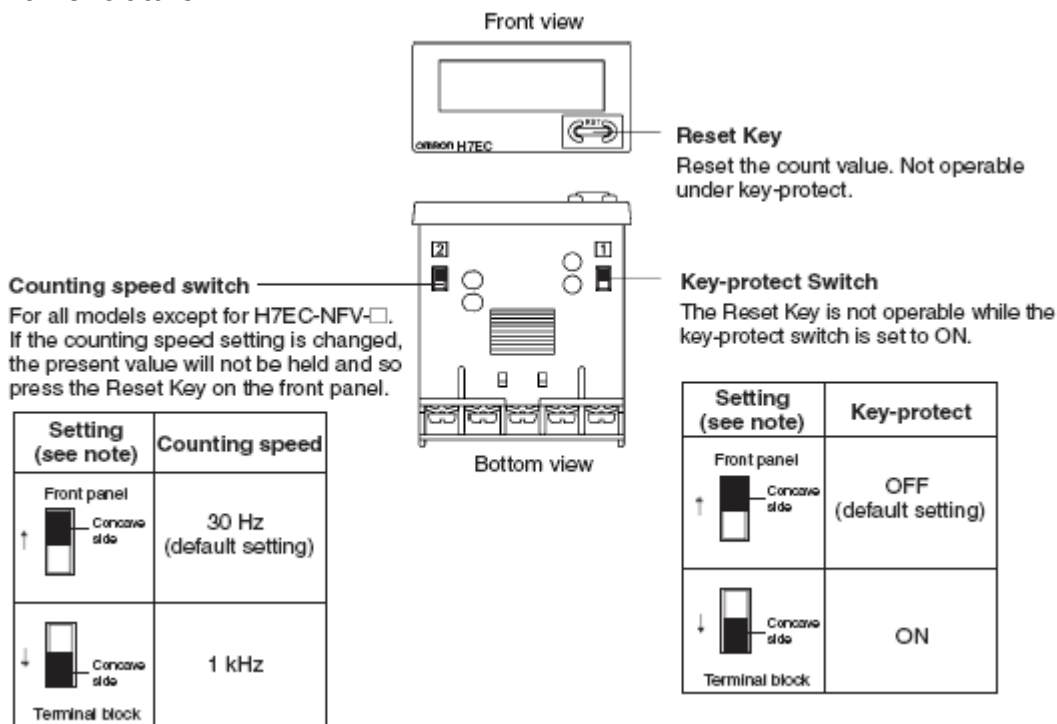

Battery replacement

Remove the wiring when replacing the battery. Do not come in contact with any item to which high voltage is being applied. Doing so may result in electric shock.

Before changing the Battery, the person should ensure that they are not carrying any static electric charge.

Procedure for replacing the Battery (refer to the diagrams below):

1. Using the tool, pry open the lift-tab on the case. (1)
2. Pull the body out of its outer case. (2)
3. Lift the Battery up by the edge and remove it. (3)

When removing the Battery, do not come in contact with the display area or any internal parts.

4. Wipe the back of the new battery before inserting it.
5. Ensure that the + and – terminals are correctly oriented.
6. After replacing the Battery, re-insert the body into its case. (4)

Check that the case is securely held in by the lift-tab

7. Press the Reset Key before use (not necessary for H7ER-N, -NV, -NV1). (5)

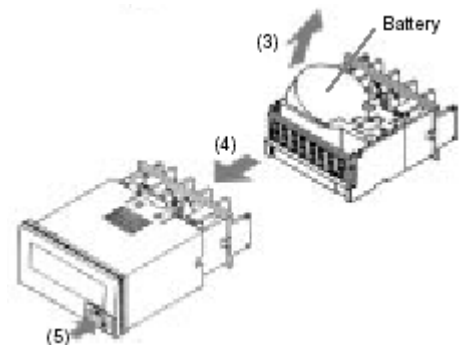
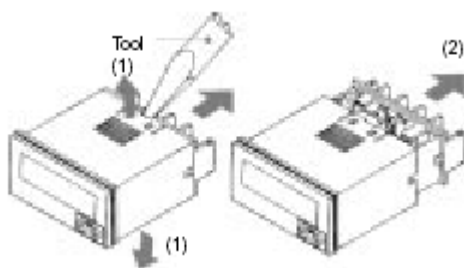

10 ALARM PANEL



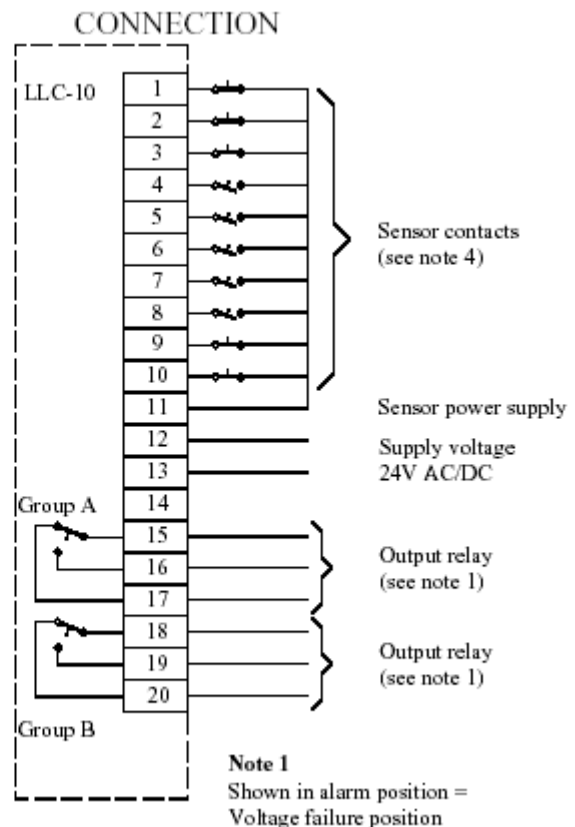
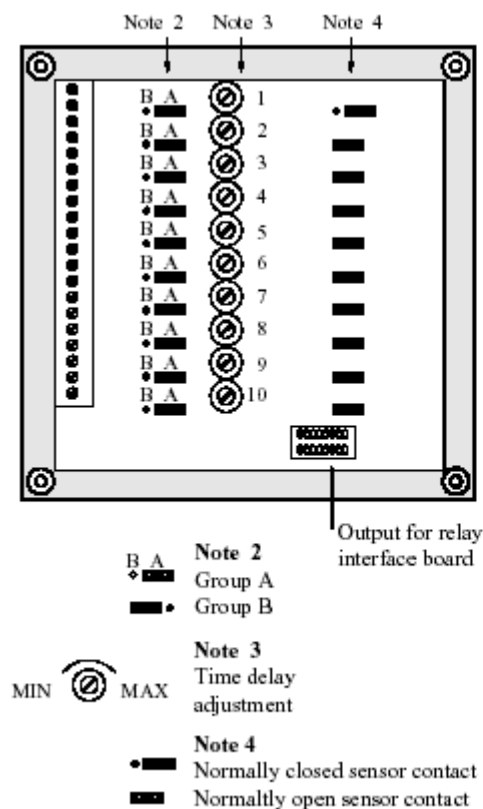

LLC-10 is a compact alarm display unit in the "DIN"-series. It is designed for exacting applications. The unit is programmable for use with either normally open or closed sensor contacts, and with adjustable time delay for each alarm channels. The alarm channels can be connected to either of the two output groups (A and B alarms). At the panel, the sensors indicator flashes when the pre-set time delay has elapsed. At the same time the output group to which it is connected, is activated. The signal is acknowledged by pressing the red RESET button. This releases the output contact and the flashing light becomes steady. When the fault has been corrected and the sensor contact has returned to its normal state, the indicator lamp goes out. If the fault self-corrects and the sensor contact returns before acknowledgement, the fault remains in the unit memory, the light flashes and the output contact remains activated, until the accept button is pressed. LLC-10 is equipped with a channel memory. The unit is always ready to receive new alarm signals, independent of system status. The panel can be provided with legends for each alarm channel or with a common 10 points legend.

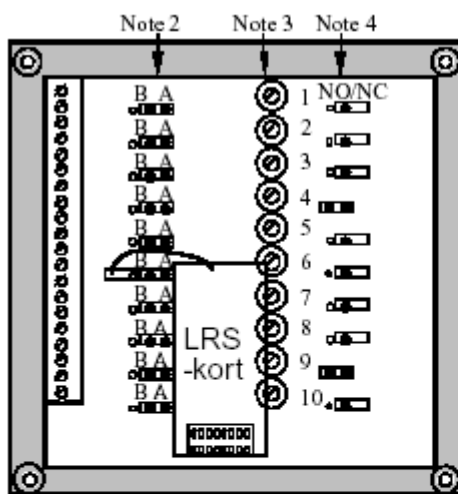

10.1 Alarm panel for units with LRS classification

LLC-10 LRS is a compact alarm display unit in the "DIN"-series. It is designed for exacting applications. The unit is programmable for use with either normally open or closed sensor contacts, with adjustable time delay. The alarm system has two output groups (A and B alarms). All channels shall be connected for A-alarm. At the panel, the sensors indicator flashes when the pre-set time delay has elapsed. At the same time the both output group is activated (the B group is delayed 5 sec. in relation to the A group). If a new sensor will be activated the B group relay will do a quick status change. The signal is acknowledged by pressing the red RESET button. This releases the output contact and the flashing light becomes steady. When the fault has been corrected and the sensor contact has returned to its normal state, the indicator lamp goes out. If the fault self-corrects and the sensor contact returns before acknowledgement, the fault remains in the unit memory, the light flashes and the output contact remains activated, until the accept button is pressed. LLC-10 is equipped with a channel memory. The unit is always ready to receive new alarm signals, independent of system status. The panel can be provided with legends for each alarm channel or with a common 10 points legend.



- Note 2**
 Grupp A, All channels shall be connected for A-alarm
 Grupp B, the LRS-card shall be connected to B-alarm.
- Note 3**
 Time delay adjustment
 MIN MAX
- Note 4**
 Normally closed contact
 Normally open contact

CONNECTION

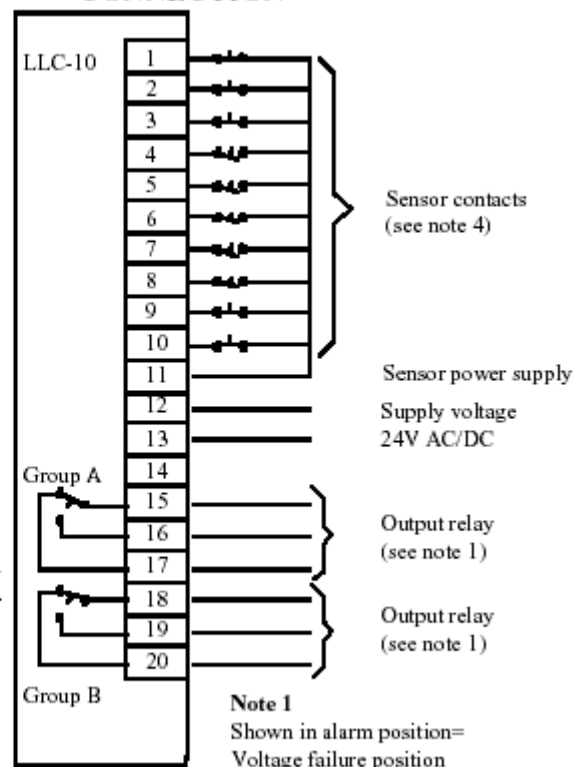

11 VISCOSITY AND TEMPERATURE CONTROLLERS E5EK

Precautions

General Precautions

Operating environment

Keep within the rated ambient operating temperature, ambient operating humidity, and storage temperature ranges.

Use the Unit according to the vibration resistance, shock resistance and enclosure ratings.

Do not use the Unit in places with corrosive gas or excessive dust.

Do not use the Unit nearby machines generating high frequency noise.

Correct use

Mounting

The dimensions of the Digital Controller conform to DIN 43700

Recommend panel thickness is 1 to 8 mm.

Mount the Unit horizontally.

Connection

To reduce inductive noise influence, the lead wires connecting the input type of the Digital Controller must be separated from the power lines and load lines

Use the specified compensating conductors for thermocouples.

Use lead wires having small resistance for platinum resistance thermometers

Connection Example

Wire the terminals of the Unit using solderless terminals.

The tightening of the torque applied to the terminal screws of the Unit must be approximately 0.78 N*m or 8 kgf*cm

Use the following type of solderless terminals for M3.5 screws-

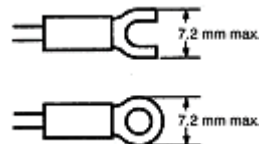

Operation

The alarm outputs of the model with an alarm function may not turn ON properly when the model malfunctions. The use of alarm equipment with the model is recommended.

The parameters and internal switch are set before shipping so that the Unit will function normally. Change the settings of the parameters and internal switch according to the application if necessary.

Several seconds are required until relay is turned ON after power has been supplied to the Digital Controller. Therefore, take this time delay into consideration when designing sequenced circuits which incorporate a Digital Controller.

Do not use excessive force when drawing out the internal mechanism from housing. Protect against static discharge when changing the settings of the internal switch. Changing the settings on a grounded conductive mat is recommended.

When connecting the Control Output Unit to the Temperature Controller or Digital Controller, make sure that the Control Output Unit is a suitable type. The use of an improper type of Control Output Unit may cause the system to malfunction.

The heater burnout alarm will not be available if the Linear output Unit is used.

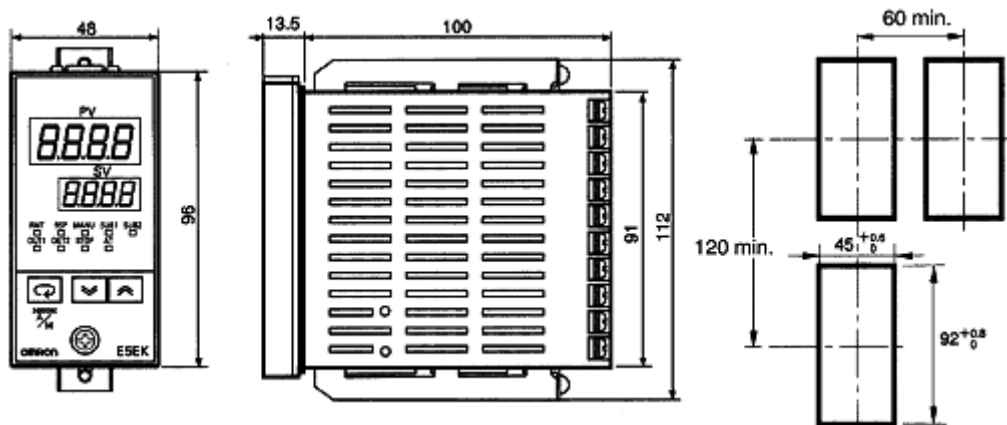

Note:

1. Recommended panel thickness is 1 to 8 mm.
2. Maintain the specified vertical and horizontal mounting space between each unit. Units must not be closely mounted vertically and horizontally.

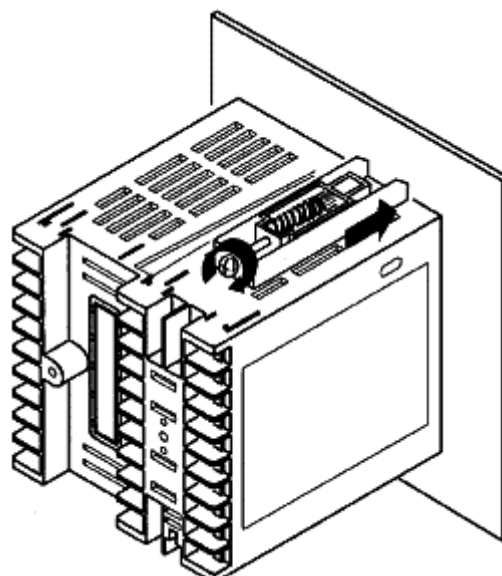
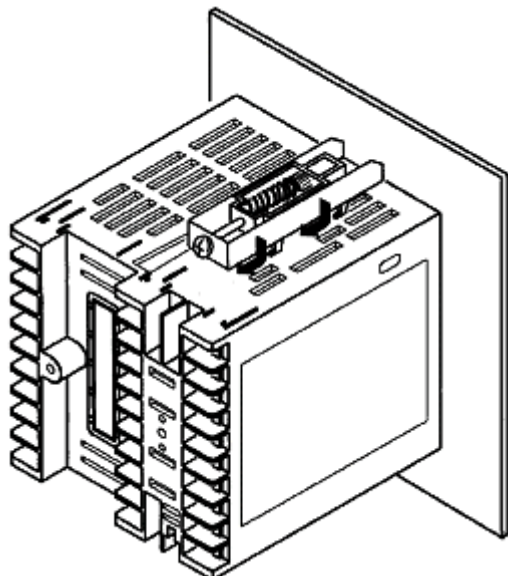

1. Insert the E5AK Controller into the panel's mounting hole at the position shown in the figure

2. Fit the mounting bracket(accessory) into the fixing slots on the top and bottom of the rear case

3. Tighten the mounting bracket screws on the upper and lower parts of the E5AK in small increments alternately and equally until the ratchet start to slide

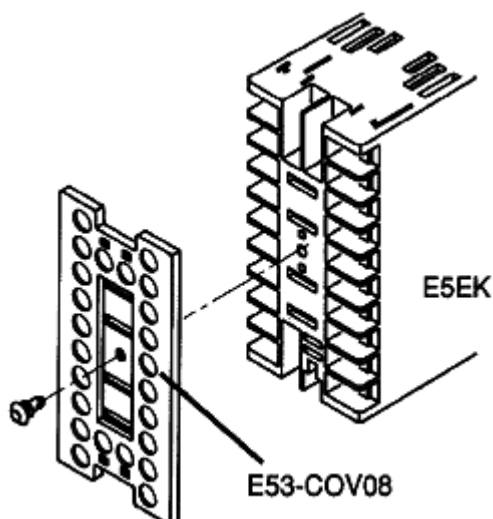

E53-COV0809, E53-COV08 Terminal Cover (Sold Separately)

Fasten the terminals covers as follows by using the snap pins. Snap pins are provided with the terminal covers

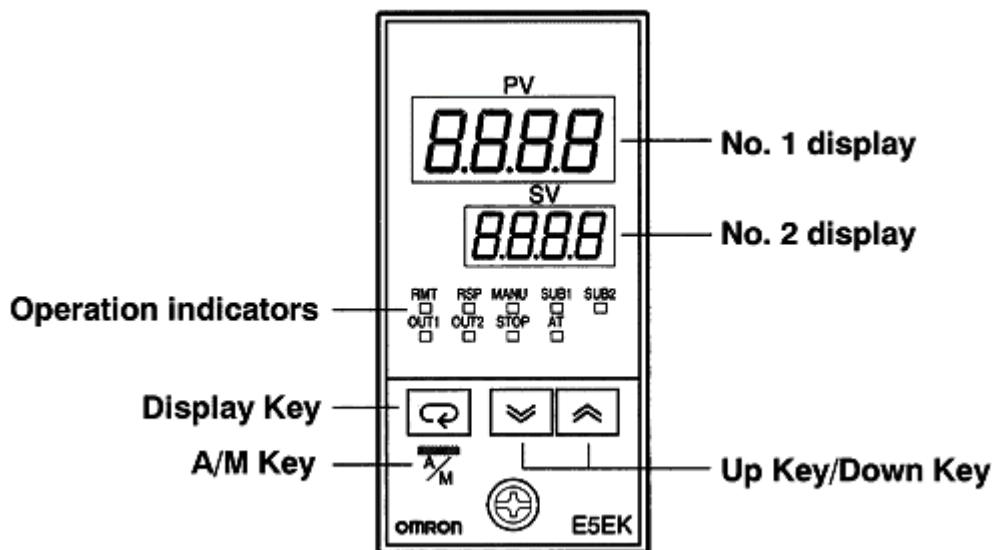

No. 1 display	Displays the process value or parameter symbols
No. 2 display	Displays the setpoint, manipulated variable or parameter settings
Out 1	Lits when the controller increases heat
Out 2	Lits when the controller decreases heat
Sub 1	Lits when the low viscosity alarm is on
Sub 2	Lits when the high viscosity alarm is on
Manu	Lits when the manual operation mode is on
Stop	Lits when operation has stopped
RMT	Lits during remote operation (not in use by Auramarine)
RSP	Lits during remote SP operation (not in use by Auramarine)
AT	Flashes during auto tuning

A/M key Each press of this key switches between the auto and manual operations.

Display key The functions of this key change according to how long it is pressed. If the key is pressed for less than one second, the parameters are switched. If the key is pressed for one second or more, the menu display appears.

Up/down-keys Each press of the up-key increments or advances the values or settings on the no. 2 display, while each press of the down-key decrements or returns the values or settings on the no. 2 display.

E.g. in the normal run situation setpoints can be changed by pressing up or down keys.

11.1 Operation

Parameter settings are done by Auramarine Ltd. according to the lists below.

After power is switched on, controller starts to operate. Setpoint can be changed by pressing up or down key. Viscosity controller uses mPas and temperature controller °C.

Manual operation is executed by first pressing A/M key (MANU lits) and then operating with up key and down key. Return to auto operation by pressing A/M key (MANU goes out).

Controller can be auto tuned by setting the setting of the parameter At from Level 1 to AT-2. Auto tuning can be cancelled by setting the setting of the parameter At to OFF.

Ensure the operation of viscosity/temperature controller, if they are not installed to local control panel by Auramarine Ltd.

- a) Switch viscometer and booster pump on.
- b) If there is HFO/LFO, MDO valve in feeder/booster unit, turn it to HFO position.
- c) Open steam/thermal oil valves or switch electric heater on by control switch at local control panel.
- d) Choose controller by control switch at local control panel.
- e) Set setpoint above process value. Control valve should open or stages of electric heater should increase power.
- f) Set setpoint below process value. Control valve should close or stages of electric heater should decrease power.
- g) In case of malfunction, check wiring.
- h) Set setpoint to normal and viscosity control on.

In case of trouble, the following should be checked:

- 1) Connections are done according to the electrical drawings.
- 2) Controller is supplied with AC 100...240 V 50/60 Hz.
- 3) Transmitter of process value gives correct signal. Signal error is displayed in no.1 display "S.Err".
- 4) Parameter settings are according to the lists below.

In case of process value hunting, it is recommended to increase the setting of the parameter I (integral time) at level 1. If it does not help, it is recommended to increase also the setting of the parameter P (proportional band) at level 1.

11.2 Access to parameters

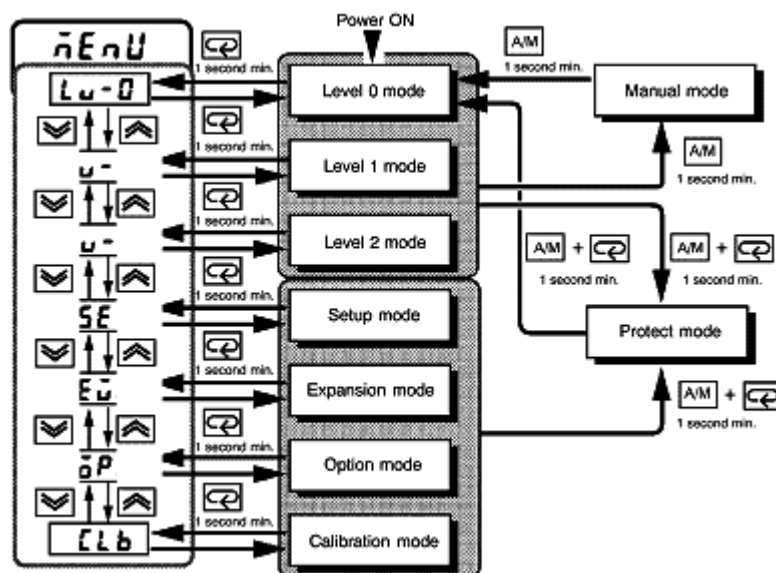
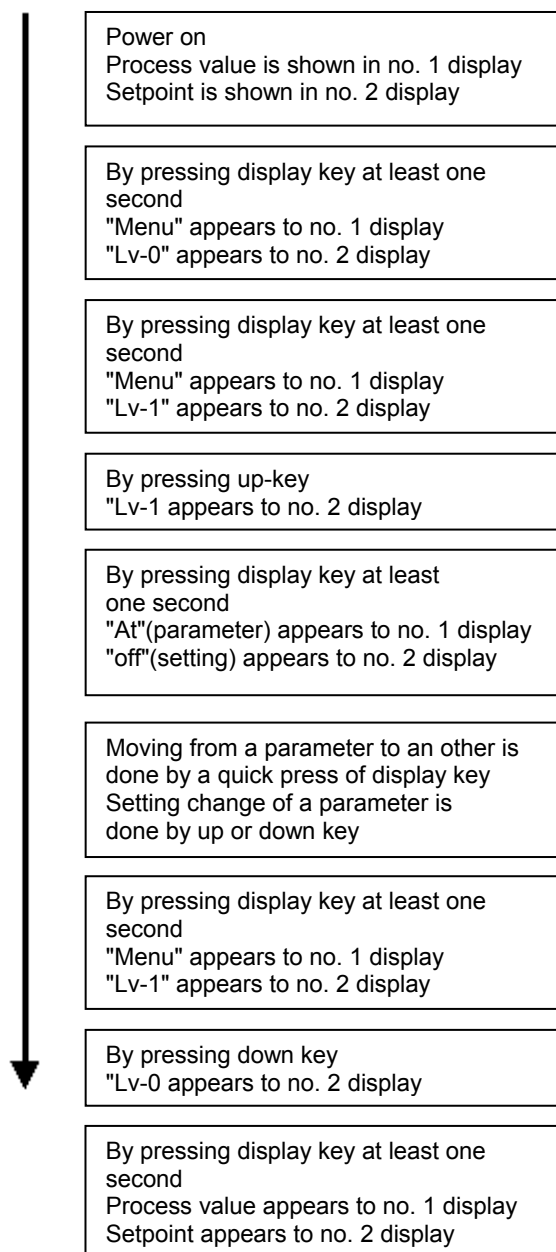

Protect mode is set to 3 to allow changes only at levels 0 and 1, and it is not recommended to go any other levels.

Access to other levels by pressing A/M key and display key simultaneously at least one second until "SECr" appears to no. 1 display and then changing 3 to 1 to no. 2 display by pressing down key. Exit from protect mode is done by pressing A/M key and display key simultaneously at least one second.

11.3 Parameter settings of the viscosity controller A16A1

If setting column is empty default is used.

Mode	Parameter Name	Setting Range	Unit	Default	Remarks	Setting
Protect	SECr Security	0 to 6	None	1		3
	KEYP [A/M] key protect	ON/OFF	None	OFF		
Manual	Manual MV	-5.0 to 105.0 *1	%	0.0		
Level 0	Set Point	Set point lower limit to Set point upper limit	EU	0		
	r-s Run/Stop	Run/Stop	None	Run		
Level 1	AT AT Execute/Cancel	OFF/AT-1/AT-2	None	OFF	During running	
	SP-0 Set point 0	Set point lower limit to Set point upper limit	EU	0	Multi-SP	
	SP-1 Set point 1	Set point lower limit to Set point upper limit	EU	0	Multi-SP	
	SP-2 Set point 2	Set point lower limit to Set point upper limit	EU	0	Multi SP	
	SP-3 Set point 3	Set point lower limit to Set point upper limit	EU	0	Multi-SP	
	AL-1 Alarm value 1	-1999 to 9999	EU	0		3
	AL-2 Alarm value 2	-1999 to 9999	EU	0		3
	AL-3 Alarm value 3	-1999 to 9999	EU	0		
	P Proportional band	0.1 to 999.9	%FS	10.0		10
	I Integral time	0 to 3999	sec	233		240
	d Derivate time	0 to 3999	sec	40		0
	C-SC Cooling coefficient	0.01 to 99.99	None	1.00	At heating and cooling control	
	C-db Dead band	-19.99 to 99.99	%FS	0.00	At heating and cooling control	
	Db Position-proportional dead band	0.1 to 10.00	%	2.0	At position-proportional control	0.3
	mF-r Manual reset value	0.0 to 100.0	%	50.0		
	HYS Hysteresis (heat)	0.01 to 99.99	%FS	0.10		
	CHYS Hysteresis (cool)	0.01 to 99.99	%FS	0.10	At heating and cooling control	
	CP Control period (heat)	1 to 99	sec	20		
	C-CP Control period (cool)	1 to 99	sec	20	At heating and cooling control	
	Hb Heater burnout	0.0 to 50.0	A	0.0	Heater burnout detection	
Level 2	r-L Remote/Local	RMT/LCL	None	LCL	Communications units settings	
	SPmd SP mode	RSP/LSP	None	LSP		
	SPrU SP ramp time unit	M(Minutes) / H(Hours)	None	M		
	SPrs SP ramp set value	0 to 9999	EU	0		
	LBA LBA detection time	0 to 9999 *1	sec	0		
	mv-S MV at stop	-5.0 to 105.0 *1	%	0.0		HOLD
	mv-E MV at PV error	-5.0 to 105.0 *2	%	0.0		HOLD
	ML-H MV upper limit	MV lower limit + 0.1 to 105.0 *3	%	105.0		
	ML-L MV lower limit	-5.0 to MV upper limit -0.1	%	-5.0		
	MrL MV change rate limit	0.0 to 100.0	%/sec	0.0		
	InF Input digital filter	0 to 9999	sec	0		
	OC-H Open/close hysteresis	0.1 to 20.0	%	0.8		0.5
	ALH1 Alarm 1 hysteresis	0.01 to 99.99	%	0.02		1.0
	ALH2 Alarm 2 hysteresis	0.01 to 99.99	%	0.02		1.0
	ALH3 Alarm 3 hysteresis	0.01 to 99.99	%	0.02		
	InSH Input shift upper limit	-199.9 to 999.9	°C/°F	0.0	Temperature input	
	InSL Input shift lower limit	-199.9 to 999.9	°C/°F	0.0	Temperature input	

*1 During heat and cooling control, the lower limit becomes -105.5%. During position-proportional control the setting becomes HOLD, OPEN or CLOSE. *2 During heat and cooling control, the setting range becomes 0.0 to 105.0%. *3 During heat and cooling control, the setting range becomes -105.0 to 0.0%.

Mode	Parameter Name	Setting Range	Unit	Default	Remarks	Setting
Setup	In-T Input type	0 to 21	None	2		17
	In-H Scaling upper limit	Scaling lower limit +1 to 9999 *4	EU	-100	Analog input	50
	In-L Scaling lower limit	-1999 to SP setting upper limit 0.1*4	EU	0	Analog input	0
	dP Decimal point	0 to 3	None	0	Analog input	
	d-U °C/°F selection	°C/°F	None	°C	Temperature input	
	InI T Parameter initialize	Yes/No	None	No		
	OUT1 Control output 1 assignment	Heat/Cool/Alarm1/Alarm2/Alarm3/HBA/LBA	None	HEAT		
	OUT2 Control output 2 assignment	Heat/Cool/Alarm1/Alarm2/Alarm3/HBA/LBA	None	AL-1		
	SUB1 Auxiliary output1 assignment	Alarm1/Alarm2/Alarm3/HBA/LBA/ S.ERR/E333/RSER	None	AL-2		AL1
	SUB2 Auxiliary output 2 assignment	Alarm1/Alarm2/Alarm3/HBA/LBA/ S.ERR/E333/RSER	None	AL-3		AL2
	AL T1 Alarm 1 type	1 to 11	None	2	Output assignment needer	3
	AL 1n Alarm 1 open in alarm	N-O/N-C	None	N-O	Output assignment needer	N-C
	AL T2 Alarm 2 type	1 to 11	None	2	Output assignment needer	2
	AL 2n Alarm 2 open in alarm	N-O/N-C	None	N-O	Output assignment needer	N-C
	AL T3 Alarm 3 type	1 to 11	None	2	Output assignment needer	
	AL 3n Alarm 3 open in alarm	N-O/N-C	None	N-O	Output assignment needer	
Dre v Direct / Reverse operation	OR-R/OR-D	None	OR-R		OR-D	
Expansion	SL-H Set point upper limit	Set point lower limit +1 to scaling upper limit *2	None	1300 *4		50
	SL-L Set point lower limit	Scaling lower limit to Set point upper limit -1 *2	None	-200 *4		0
	CnTL PID/ON/OFF	PID/ON/OFF	None	PID		
	ST ST	OFF/ON	None	OFF		
	ST-b ST stable range	0.1 to 999.9	°C/°F	15.0	ST=ON	
	ALFA α	0.00 to 1.00	None	0.65		
	AT-G AT calculated gain	0.1 to 10.0	None	1.0		
	ReSm Standby sequence reset setting method	0/1	None	0		
	ReM Automatic return of display mode	0 to 99	Sec	0		30
	AT-H AT hysteresis	0.1 to 9.9	%FS	0.2		0.2
LBAB LBA detection width	0.0 to 999.9	%FS	0.2			

*4 When temperature input is selected, the sensor range selected in the "input type" parameter (setup mode) correspond to the scaling upper and lower limit value.

Mode	Parameter Name	Setting Range	Unit	Default	Remarks	Setting
Option	EV-M Multi-SP function	0 to 2	None	0		
	EV-1 Event input assignment 1	NON/STOP/RMT/MAN/RSP	None	NON		
	EV-2 Event input assignment 2	NON/STOP/RMT/MAN/RSP	None	NON		
	SbCT Communication stop bit	1/2	bits	2		
	Len Communication data length	7/8	bits	7		
	Prty Communication parity	None/Even/Odd	None	EVEN		
	BPS Communication baud value	1.2/2.4/4.8/9.6/19.2	kbps	9.6		
	U-no Communication unit No.	0 to 99	None	0		
	Tr-T Transfer output type	SP/SP-M/PV/O/C-O/V-M	None	SP		
	Tr-H Transfer output upper limit	*5	*5	*5		
	Tr-L Transfer output lower limit	*5	*5	*5		
	HbL HBA latch	ON/OFF	None	OFF		
	CALb Motor calibration	ON/OFF	None	OFF		
	MoT Travel time	1 to 999	Sec	1		
	P-db PV dead band	0 to 9999	EU	0		
	rSPU Remote SP enable	ON/OFF	None	OFF		
	rSPH Remote SP upper limit	SP setting lower limit to SP setting upper limit	EU	1300		
	rSPL Remote SP lower limit	SP setting lower limit to SP setting upper limit	EU	-200		
	SPTr SP tracking	ON/OFF	None	OFF		

*5 Set the transfer output type parameter according to the following table.

Transfer Output Type	Transfer Output Lower Limit to Transfer Output Upper Limit
SP :Set point	Set point lower limit to Set point upper limit
SP-M :Set point during SP ramp	Set point lower limit to Set point upper limit
PV :Process value	Scaling lower limit to scaling upper limit
O :Manipulated variable(heat)	-5.0 to 105.0%
C-O :Manipulated variable(cool)	0.0 to 105.0%
V-M :Value opening	-10.0 to 110.0%

- Default : SP
- The output ranges of the SP settings, set point or process value when temperature input is selected are the ranges supported by the selected sensor.
- When the heating side manipulated variable or cooling side manipulated variable is selected, the transfer output lower limit in a heating and cooling control becomes 0.0.

11.4 Parameter settings of the temperature controller A16A2

If setting column is empty default is used.

Mode	Parameter Name	Setting Range	Unit	Default	Remarks	Setting
Protect	SECr Security	0 to 6	None	1		3
	KEYP [A/M] key protect	ON/OFF	None	OFF		
Manual	Manual MV	-5.0 to 105.0 *1	%	0.0		
Level 0	Set Point	Set point lower limit to Set point upper limit	EU	0		
	r-s Run/Stop	Run/Stop	None	Run		
Level 1	AT AT Execute/Cancel	OFF/AT-1/AT-2	None	OFF	During running	
	SP-0 Set point 0	Set point lower limit to Set point upper limit	EU	0	Multi-SP	
	SP-1 Set point 1	Set point lower limit to Set point upper limit	EU	0	Multi-SP	
	SP-2 Set point 2	Set point lower limit to Set point upper limit	EU	0	Multi SP	
	SP-3 Set point 3	Set point lower limit to Set point upper limit	EU	0	Multi-SP	
	AL-1 Alarm value 1	-1999 to 9999	EU	0		10
	AL-2 Alarm value 2	-1999 to 9999	EU	0		10
	AL-3 Alarm value 3	-1999 to 9999	EU	0		
	P Proportional band	0.1 to 999.9	%FS	10.0		2
	I Integral time	0 to 3999	sec	233		240
	d Derivate time	0 to 3999	sec	40		
	C-SC Cooling coefficient	0.01 to 99.99	None	1.00	At heating and cooling control	
	C-db Dead band	-19.99 to 99.99	%FS	0.00	At heating and cooling control	
	Db Position-proportional dead band	0.1 to 10.00	%	2.0	At position-proportional control	0.8
	mF-r Manual reset value	0.0 to 100.0	%	50.0		
	HYS Hysteresis (heat)	0.01 to 99.99	%FS	0.10		
	CHYS Hysteresis (cool)	0.01 to 99.99	%FS	0.10	At heating and cooling control	
	CP Control period (heat)	1 to 99	sec	20		
	C-CP Control period (cool)	1 to 99	sec	20	At heating and cooling control	
Hb Heater burnout	0.0 to 50.0	A	0.0	Heater burnout detection		
Level 2	r-L Remote/Local	RMT/LCL	None	LCL	Communications units settings	
	SPmd SP mode	RSP/LSP	None	LSP		
	SPrU SP ramp time unit	M(Minutes) / H(Hours)	None	M		
	SPrs SP ramp set value	0 to 9999	EU	0		
	LBA LBA detection time	0 to 9999 *1	sec	0		
	mv-S MV at stop	-5.0 to 105.0 *1	%	0.0		HOLD
	mv-E MV at PV error	-5.0 to 105.0 *2	%	0.0		HOLD
	ML-H MV upper limit	MV lower limit + 0.1 to 105.0 *3	%	105.0		
	ML-L MV lower limit	-5.0 to MV upper limit -0.1	%	-5.0		
	MrL MV change rate limit	0.0 to 100.0	%/sec	0.0		
	InF Input digital filter	0 to 9999	sec	0		
	OC-H Open/close hysteresis	0.1 to 20.0	%	0.8		0.5
	ALH1 Alarm 1 hysteresis	0.01 to 99.99	%	0.02		0.25
	ALH2 Alarm 2 hysteresis	0.01 to 99.99	%	0.02		0.25
	ALH3 Alarm 3 hysteresis	0.01 to 99.99	%	0.02		
	InSH Input shift upper limit	-199.9 to 999.9	°C/°F	0.0	Temperature input	
	InSL Input shift lower limit	-199.9 to 999.9	°C/°F	0.0	Temperature input	

*1 During heat and cooling control, the lower limit becomes -105.5%. During position-proportional control the setting becomes HOLD, OPEN or CLOSE. *2 During heat and cooling control, the setting range becomes 0.0 to 105.0%. *3 During heat and cooling control, the setting range becomes -105.0 to 0.0%.

Mode	Parameter Name	Setting Range	Unit	Default	Remarks	Setting
Setup	In-T Input type	0 to 21	None	2		1
	In-H Scaling upper limit	Scaling lower limit +1 to 9999 *4	EU	-100	Analog input	
	In-L Scaling lower limit	-1999 to SP setting upper limit 0.1*4	EU	0	Analog input	
	dP Decimal point	0 to 3	None	0	Analog input	
	d-U °C/°F selection	°C/°F	None	°C	Temperature input	
	inIT Parameter initialize	Yes/No	None	No		
	OUT1 Control output 1 assignment	Heat/Cool/Alarm1/Alarm2/Alarm3/HBA/LBA	None	HEAT		
	OUT2 Control output 2 assignment	Heat/Cool/Alarm1/Alarm2/Alarm3/HBA/LBA	None	AL-1		
	SUB1 Auxiliary output1 assignment	Alarm1/Alarm2/Alarm3/HBA/LBA/ S.ERR/E333/RSER	None	AL-2		AL1
	SUB2 Auxiliary output 2 assignment	Alarm1/Alarm2/Alarm3/HBA/LBA/ S.ERR/E333/RSER	None	AL-3		AL2
	ALT1 Alarm 1 type	1 to 11	None	2	Output assignment needer	3
	AL1n Alarm 1 open in alarm	N-O/N-C	None	N-O	Output assignment needer	N-C
	ALT2 Alarm 2 type	1 to 11	None	2	Output assignment needer	2
	AL2n Alarm 2 open in alarm	N-O/N-C	None	N-O	Output assignment needer	N-C
	ALT3 Alarm 3 type	1 to 11	None	2	Output assignment needer	
	AL3n Alarm 3 open in alarm	N-O/N-C	None	N-O	Output assignment needer	
	Drev Direct / Reverse operation	OR-R/OR-D	None	OR-R		
Expansion	SL-H Set point upper limit	Set point lower limit +1 to scaling upper limit *2	None	1300 *4		
	SL-L Set point lower limit	Scaling lower limit to Set point upper limit -1 *2	None	-200 *4		
	CnTL PID/ON/OFF	PID/ON/OFF	None	PID		
	ST ST	OFF/ON	None	OFF		
	ST-b ST stable range	0.1 to 999.9	°C/°F	15.0	ST=ON	
	ALFA α	0.00 to 1.00	None	0.65		
	AT-G AT calculated gain	0.1 to 10.0	None	1.0		
	ReSm Standby sequence reset setting method	0/1	None	0		
	ReM Automatic return of display mode	0 to 99	Sec	0		30
	AT-H AT hysteresis	0.1 to 9.9	%FS	0.2		
LBAB LBA detection width	0.0 to 999.9	%FS	0.2			

*4 When temperature input is selected, the sensor range selected in the "input type" parameter (setup mode) correspond to the scaling upper and lower limit value.

Mode	Parameter Name	Setting Range	Unit	Default	Remarks	Setting
Option	EV-M Multi-SP function	0 to 2	None	0		
	EV-1 Event input assignment 1	NON/STOP/RMT/MAN/RSP	None	NON		
	EV-2 Event input assignment 2	NON/STOP/RMT/MAN/RSP	None	NON		
	SbCT Communication stop bit	1/2	bits	2		
	Len Communication data length	7/8	bits	7		
	Prty Communication parity	None/Even/Odd	None	EVEN		
	BPS Communication baud value	1.2/2.4/4.8/9.6/19.2	kbps	9.6		
	U-no Communication unit No.	0 to 99	None	0		
	Tr-T Transfer output type	SP/SP-M/PV/O/C-O/V-M	None	SP		
	Tr-H Transfer output upper limit	*5	*5	*5		
	Tr-L Transfer output lower limit	*5	*5	*5		
	HbL HBA latch	ON/OFF	None	OFF		
	CALb Motor calibration	ON/OFF	None	OFF		
	MoT Travel time	1 to 999	Sec	1		120
	P-db PV dead band	0 to 9999	EU	0		1
	rSPU Remote SP enable	ON/OFF	None	OFF		
	rSPH Remote SP upper limit	SP setting lower limit to SP setting upper limit	EU	1300		
	rSPL Remote SP lower limit	SP setting lower limit to SP setting upper limit	EU	-200		
	SPTr SP tracking	ON/OFF	None	OFF		

*5 Set the transfer output type parameter according to the following table.

Transfer Output Type	Transfer Output Lower Limit to Transfer Output Upper Limit
SP :Set point	Set point lower limit to Set point upper limit
SP-M :Set point during SP ramp	Set point lower limit to Set point upper limit
PV :Process value	Scaling lower limit to scaling upper limit
O :Manipulated variable(heat)	-5.0 to 105.0%
C-O :Manipulated variable(cool)	0.0 to 105.0%
V-M :Value opening	-10.0 to 110.0%

- Default : SP
- The output ranges of the SP settings, set point or process value when temperature input is selected are the ranges supported by the selected sensor.
- When the heating side manipulated variable or cooling side manipulated variable is selected, the transfer output lower limit in a heating and cooling control becomes 0.0.

12 PRESSURE SWITCH MBC 5000, 5100

Electrical connection

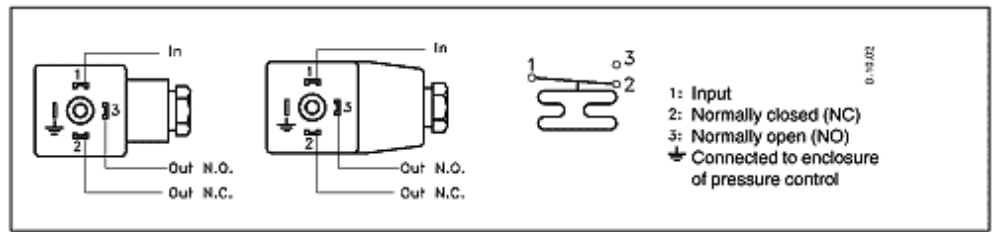

Mechanical connection

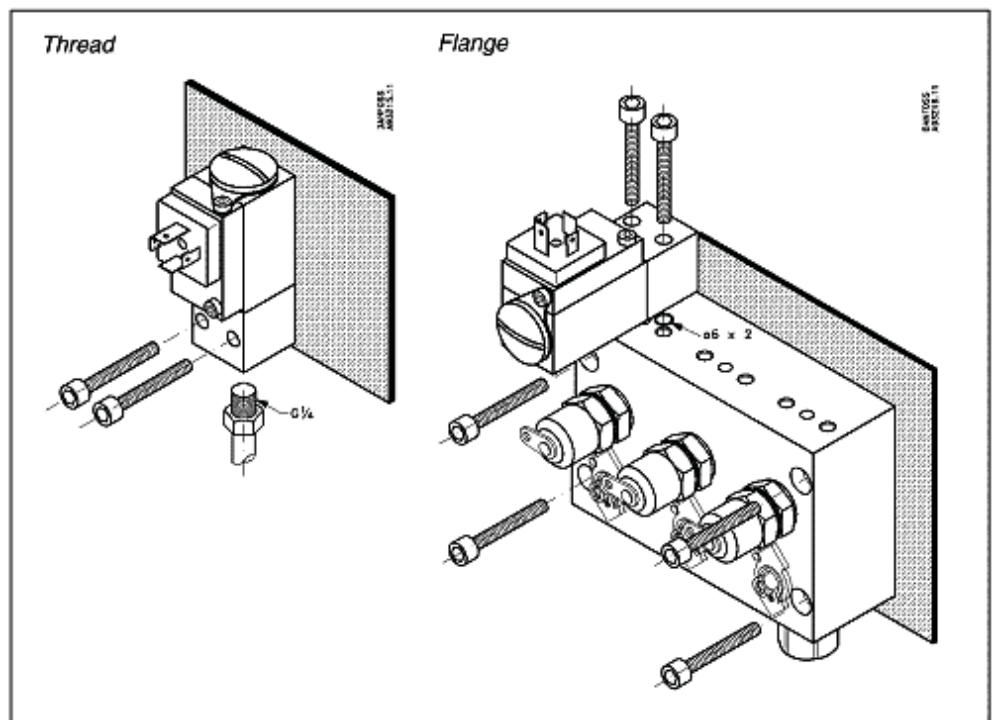

Adjustment

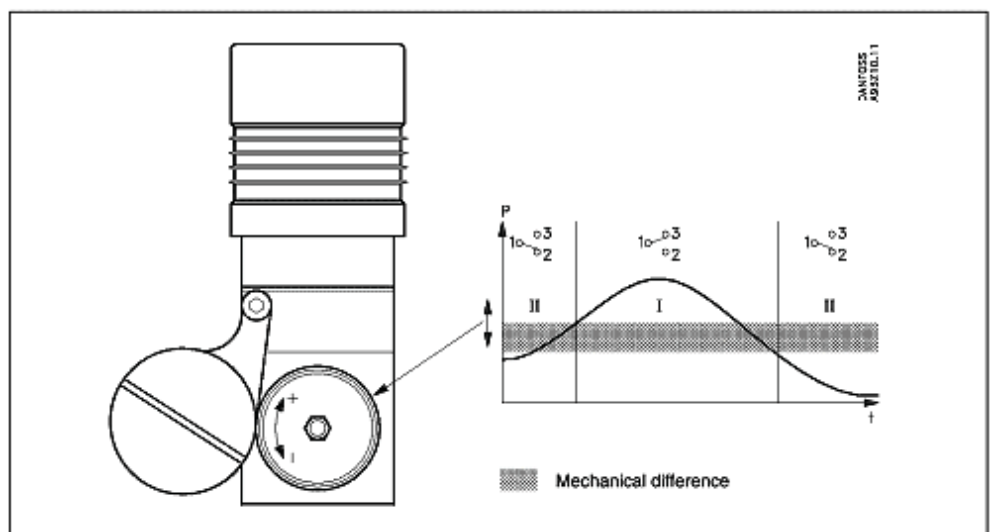

13 LEVEL LIMIT SWITCH LIQUIPHANT T FTL20



The device may be installed, connected, commissioned, operated and maintained by qualified and authorised personnel only.

Do not bend.

Do not shorten.

Do not lengthen.

13.1 Instructions

1. Handling

Hold by the housing, not by the sensor fork

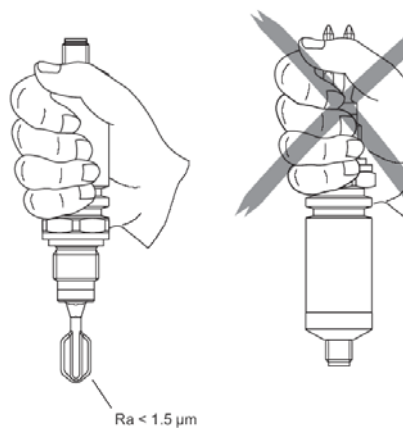

2. Take account of viscosity and build-up

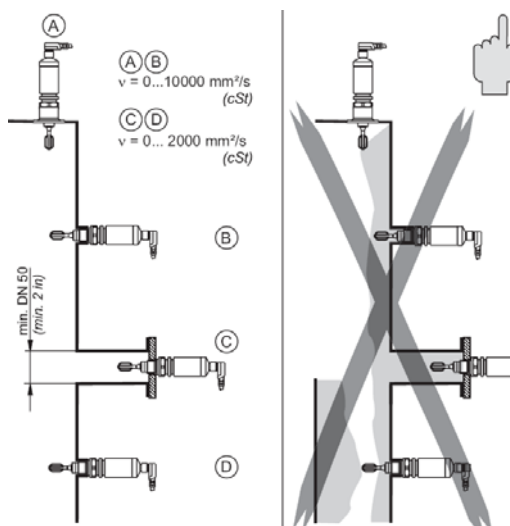

3. Align sensor fork Note mark ▼

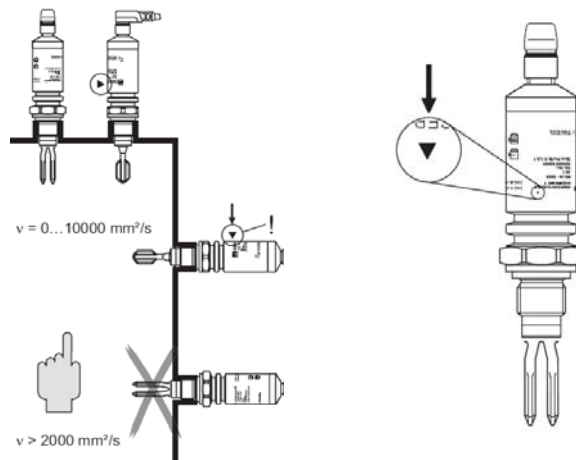

4. Test with test magnet

 MAX	1. gn ye → 2. gn ye
 MIN	1. gn ye → 2. gn ye
 MAX MIN	1. gn rd → 2. gn rd

5. Cleaning



14 FLOW METER, TYPE VZF



Before working on the hydraulics, put the plant or section out of operation, close the stop valves and release the pressure

Comply with the permissible operating data as defined on the type plate. Pressure test with a maximum of 1.5 x the nominal pressure (PN).

Make sure that no hazardous fumes can build up in the piping and in the meter during commissioning, decommissioning and dismantling.

The meter must at all times be completely filled with liquid during operation.

Check the meter periodically for tightness of the connections and for proper functioning.

If work is to be done on the installation, before each intervention:

- **release the pressure in the installation**
- **if hazardous liquids are used, wear protective clothing and safety goggles**
- **place a collecting tray underneath the installation.**

When restarting the plant:

- **slowly open the stop valves, avoiding pressure surges ('water hammer')**
- **vent the pipe well**
- **check tightness**

14.1 Display

All data are saved periodically, and every time a key is pressed, in a non-volatile memory (EEPROM). This means that the last value is saved even if the power supply is interrupted.

The 7-segment display can show 8-digit measured values with a decimal point or text messages using letters in a special presentation mode. Units of measurement and additional items of information are shown with symbols or index indicators. The references to these in the text are shown in square brackets, e.g. [LIMIT MAX].

The display data and parameters are split into three menu groups:

- a) Main Menu: displays measured data, accesses other menus, tests display segments and displays error messages (if present).
- b) Information Menu: displays additional information about the meter and operating status
- c) Parameter Menu: displays parameter settings for the display and output signals. To set these parameters, the device must be unlocked with the Service key. This is located in the connections compartment and is only accessible after the display module has been opened or unscrewed.

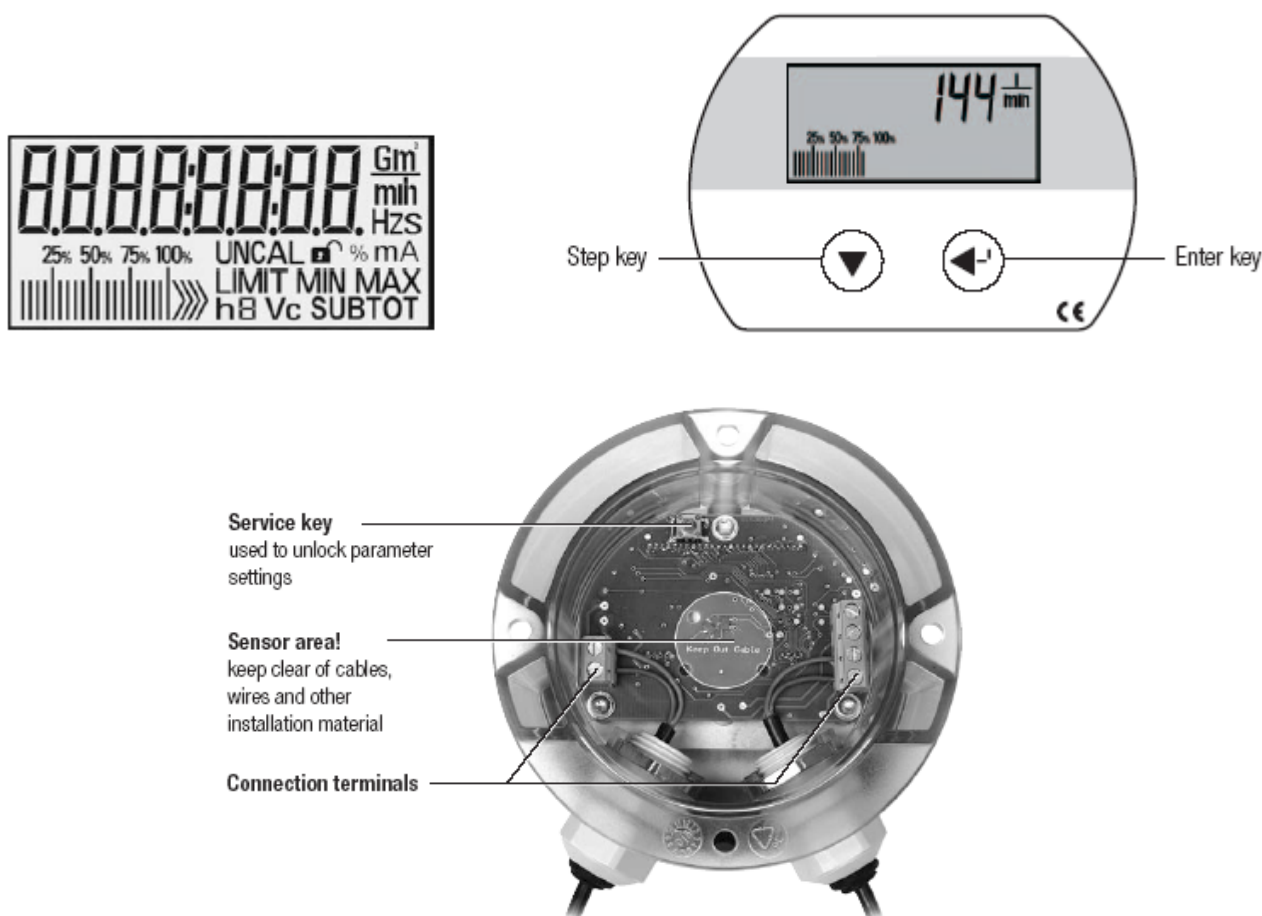

14.2 Operation

14.2.1 Main menu

The standard display of the Main Menu is the total volume. Use the Step key to go to the measured value for the resettable volume or the flow rate and other menu items, as follows:

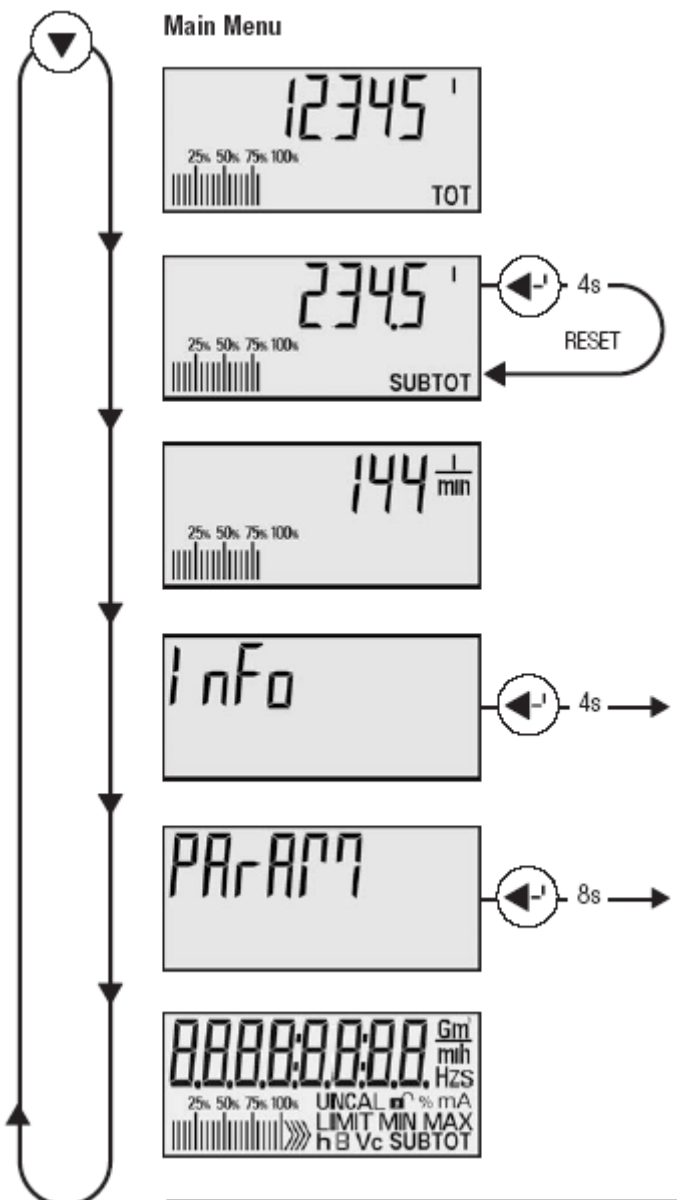

Total volume [TOT] cannot be reset
Standard display adopted by the meter after a time-out. The flow indicator bar corresponds to the meter measuring range. It shows the flow rate by means of graduation marks, in steps of 5 per cent up to Qmax.

Subtotal volume [SUBTOT] can be reset
Reset: press the Enter key for 4 seconds. Reset must be enabled in the Parameter Menu. The flow indicator bar corresponds to the meter measuring range. It shows the flow rate by means of graduation marks, in steps of 5 per cent up to Qmax.

Current flow rate
Besides being displayed numerically, this value is also shown in the display by a bar with graduation marks, each mark representing 5% of the maximum permitted flow rate.

Entry portal for the Information Menu
Display additional information about the device and operating status.
To access: press the Enter key for 4 seconds.
Time-out: 60 seconds

Entry portal for the Parameter Menu
Display and settings for device and operating parameters for display and outputs.
To access: press the Enter key for 8 seconds.
Time-Out: 60 seconds

Display test
All the segments are shown for 2 seconds for monitoring. This test is also performed after switching on the unit.

**Device errors**

If a device error is detected during the periodic self-test, this message is briefly shown on the display every 2 seconds. Measuring accuracy is impaired.



The meter may supply incorrect values. The Information Menu gives more information on the error.

The value displayed in "subtotal volume" [SUBTOT] can be reset to zero by pressing the Enter key for about 4 seconds, unless this function has been disabled in the Parameter Menu.

If a meter error is present, the [ERROR] warning appears on the display every 2 seconds. Details about the error are shown in the Information Menu.

14.2.2 Information menu

Select the [INFO] item from the Main Menu and then press the Enter key for approx.4 seconds to enter the Information Menu. Use the Step key to view the following additional information about the meter and the operating status:

Information Menu

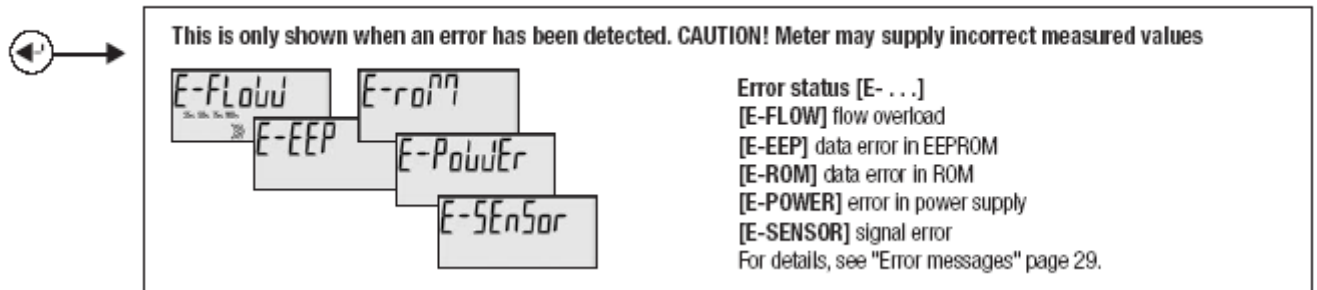

This is only shown when an error has been detected. CAUTION! Meter may supply incorrect measured values

E-Flow	E-ROM	Error status [E- . . .] [E-FLOW] flow overload [E-EEP] data error in EEPROM [E-ROM] data error in ROM [E-POWER] error in power supply [E-SENSOR] signal error For details, see "Error messages" page 29.
E-EEP	E-Power	
	E-Sensor	

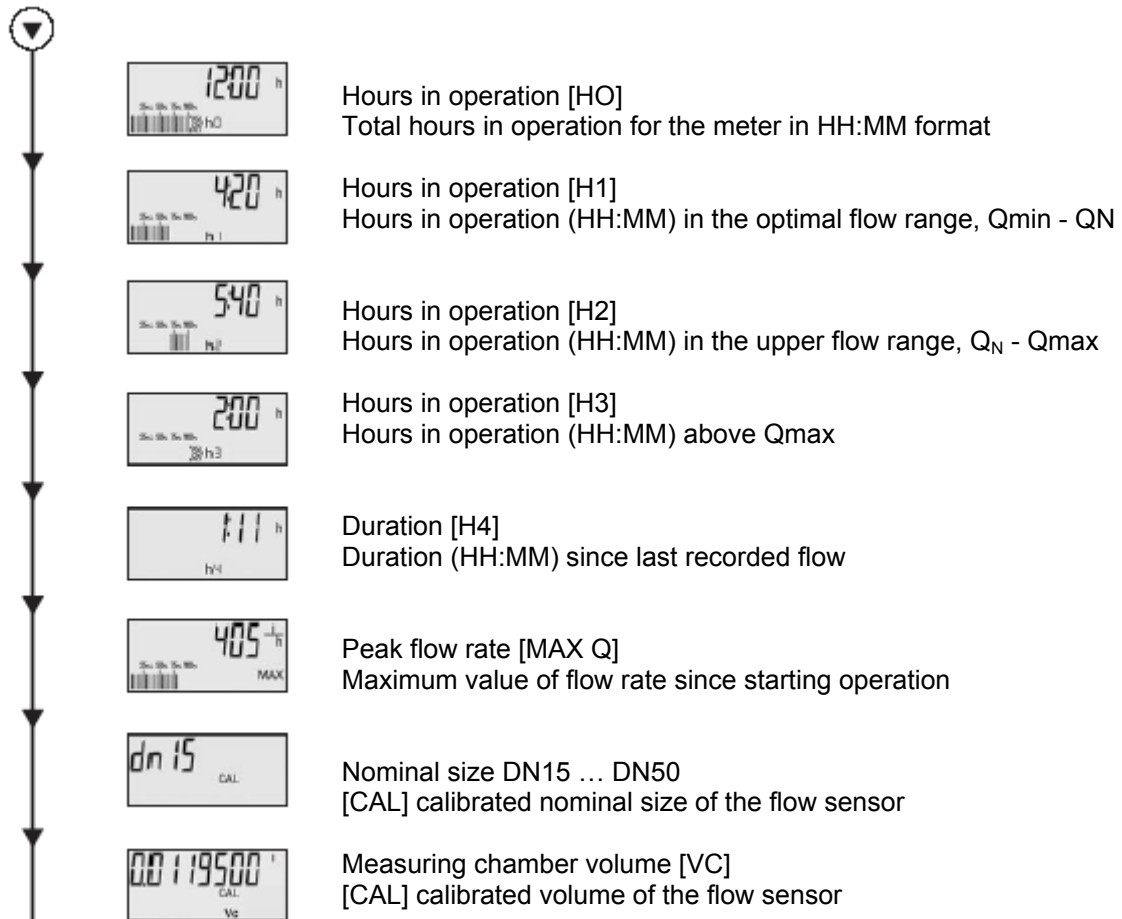

1200 h	Hours in operation [HO] Total hours in operation for the meter in HH:MM format
420 h	Hours in operation [H1] Hours in operation (HH:MM) in the optimal flow range, Qmin - QN
540 h	Hours in operation [H2] Hours in operation (HH:MM) in the upper flow range, Q _N - Qmax
200 h	Hours in operation [H3] Hours in operation (HH:MM) above Qmax
1:11 h	Duration [H4] Duration (HH:MM) since last recorded flow
405 h	Peak flow rate [MAX Q] Maximum value of flow rate since starting operation
dn 15	Nominal size DN15 ... DN50 [CAL] calibrated nominal size of the flow sensor
00119500 l	Measuring chamber volume [VC] [CAL] calibrated volume of the flow sensor

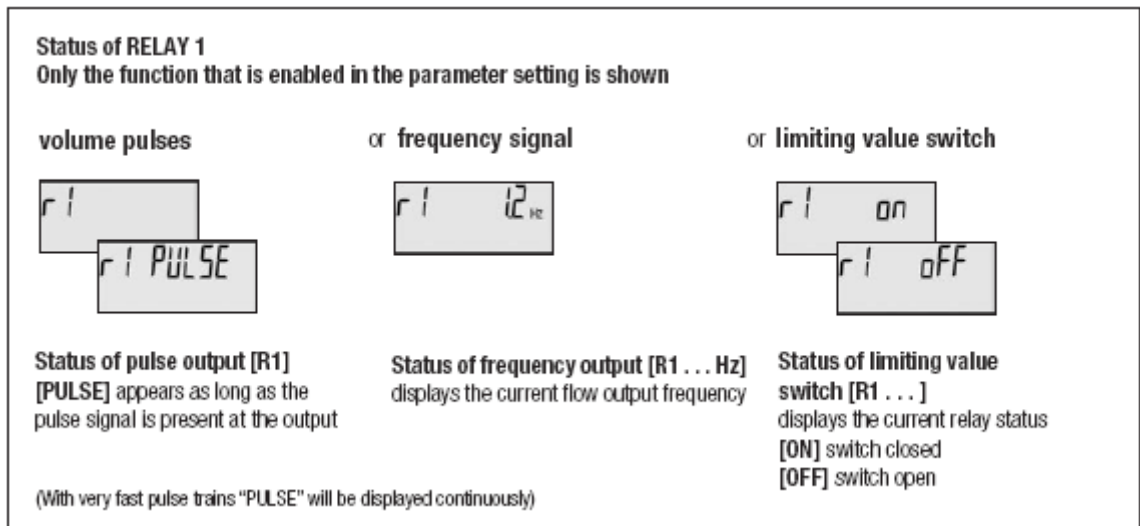
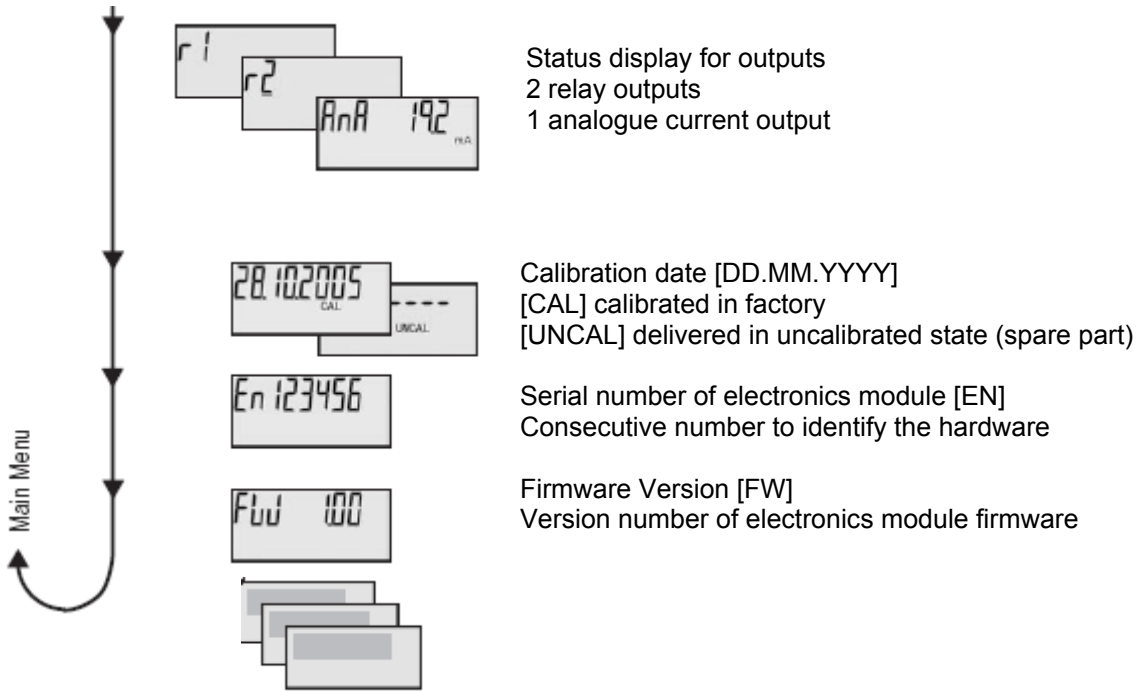

Only the second output enabled in the "Output selection" parameter setting is shown (relay 2 or analog)

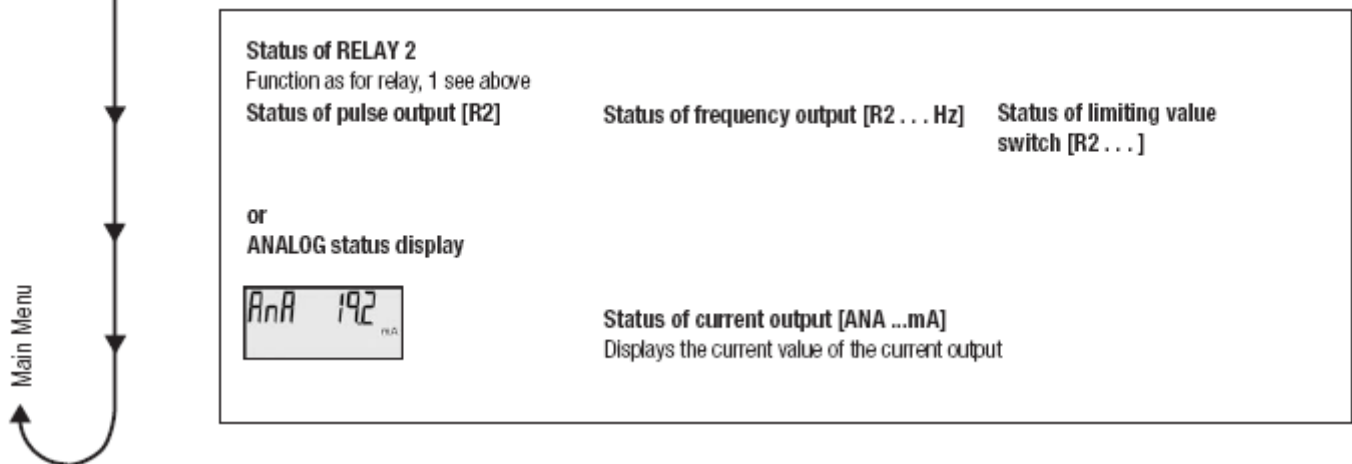



If both keys are pressed at the same time, or if no key is pressed for 60 seconds, the device returns to the standard display.

14.2.3 Parameter menu

Select the [PARAMETER] item from the Main Menu and press the Enter key for approx. 8 seconds to enter the Parameter Menu.

The menu structure for reading out parameters is shown below. Use the Step key to display all the parameters that are set. Submenus are available for the relay and power output menus; to enter them, press the Enter key.

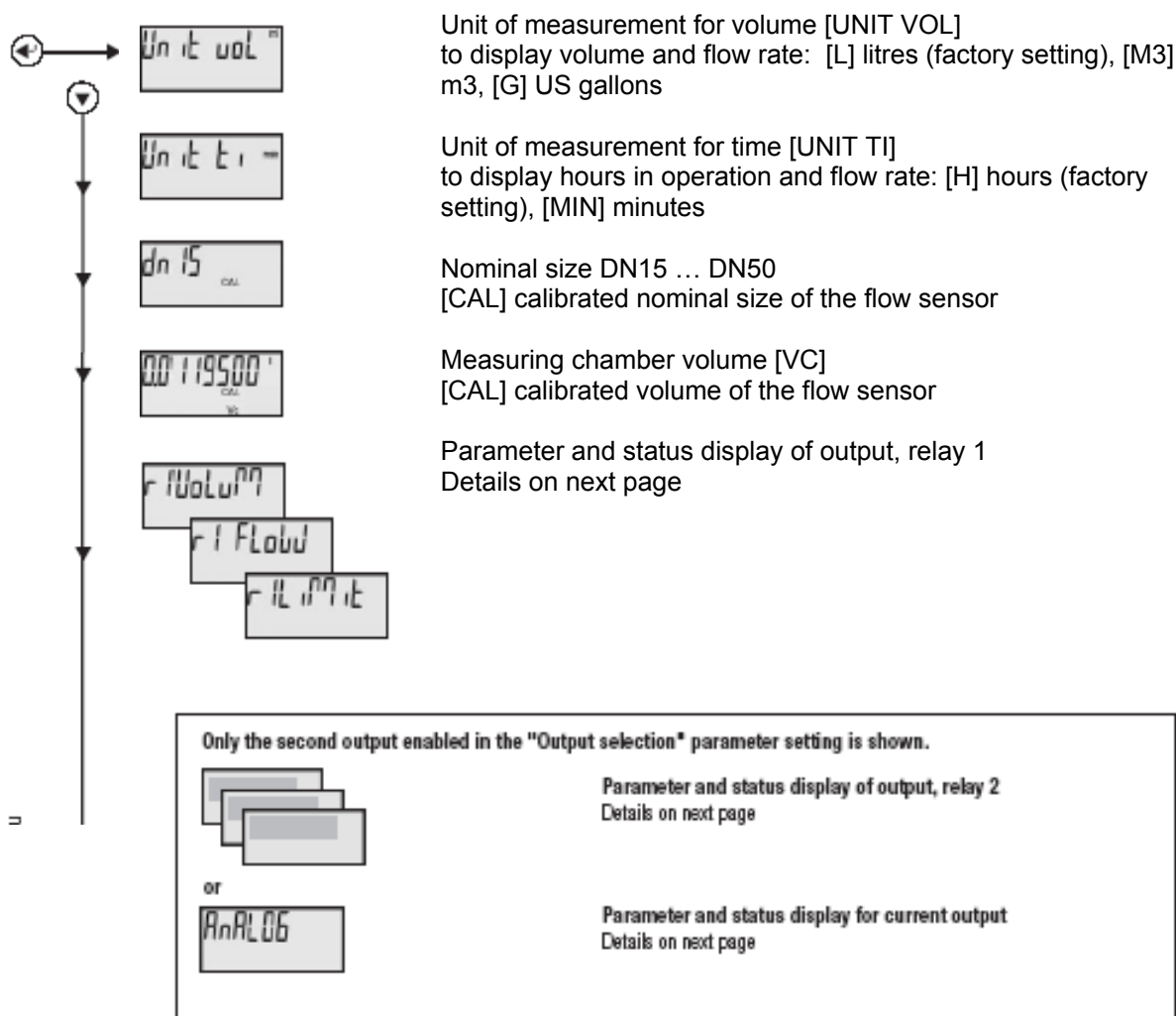

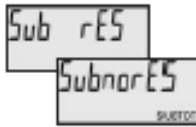



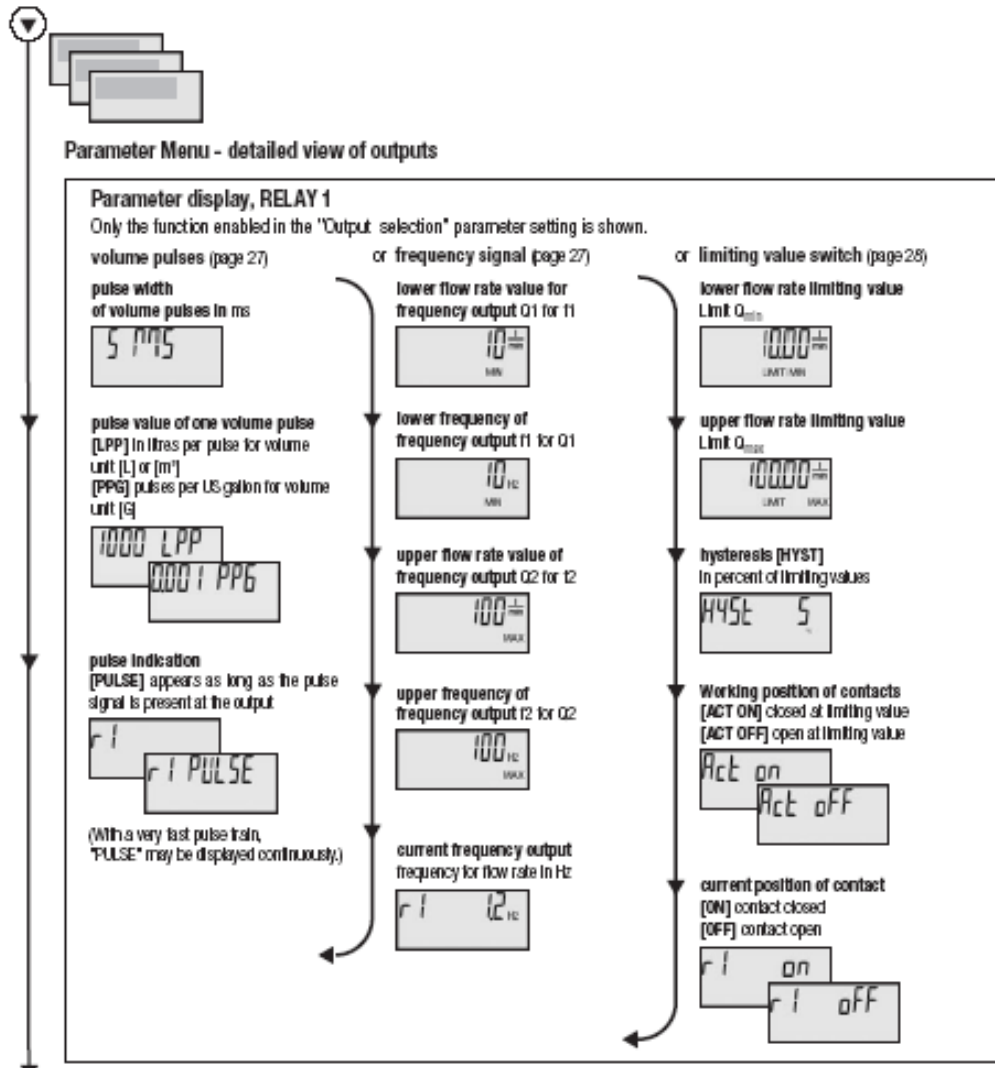

Disable volume subtotal reset [SUBTOT]
[SUB RES] Subtotal can be reset (factory setting)
[SUB.NO.RES] Subtotal cannot be reset

If both keys are pressed at the same time, or if no key is pressed within 15 minutes, the device returns to the standard display.

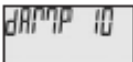
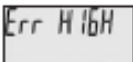

Only the second output enabled in the "Output selection" parameter setting appears (relay 2 or analog)
Parameter display, RELAY 2
 Only the function that is enabled in the parameter setting is shown:
 volume pulses or frequency signal or limiting value switch (for details see relay 1)
 or ANALOG parameter display

	lower flow rate value Q _{min} for 4mA
	upper flow rate value Q _{max} for 20mA
	Attenuation of current output [DAMP] [1] no damping [10] high damping
	Current output in case of an error [ERR...] [HIGH] 21,5mA, [LOW] 3,5mA, [OFF] no output
	current status of current output [ANA] displays the current value of the current output

Main Menu

 If both keys are pressed at the same time, or if no key is pressed within 15 minutes, the device returns to the standard display.

14.2.3.1 Parameter settings

In order to set the parameters, the device must first be unlocked with the Service key. This puts the device into Edit mode.

This is located in the connections compartment and is only accessible after the display module has been opened or unscrewed. The power supply must not be interrupted when this is done.

This unlocking procedure is only possible within the Parameter Menu and is done by pressing the Service key. Once the parameter setting is enabled, symbol  will be shown in addition to all the displays. On exiting the Parameter Menu, the Edit mode is automatically discontinued.

Parameter Menu

Press Service key =

select =

save =

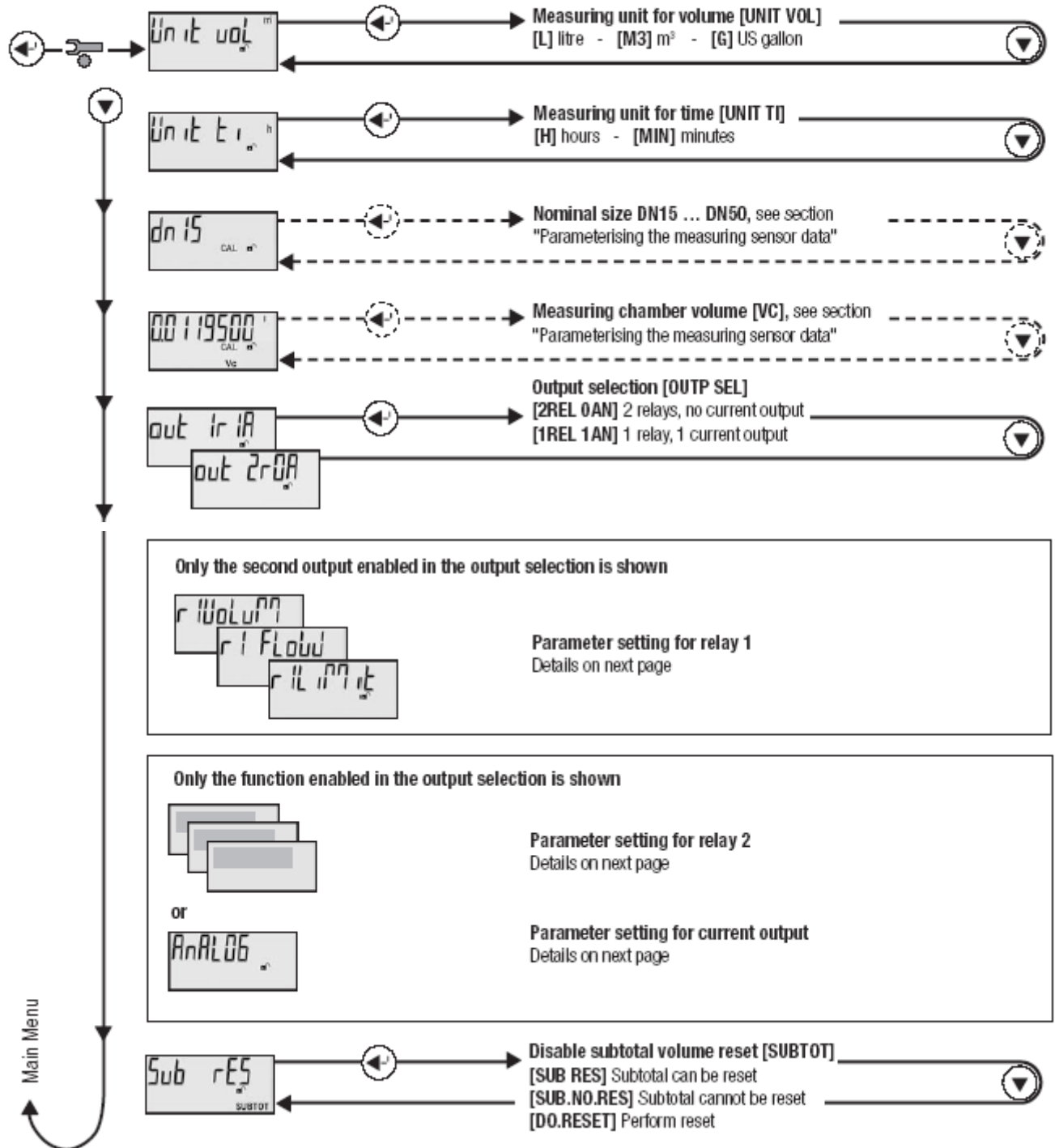

Parameter Menu - set outputs

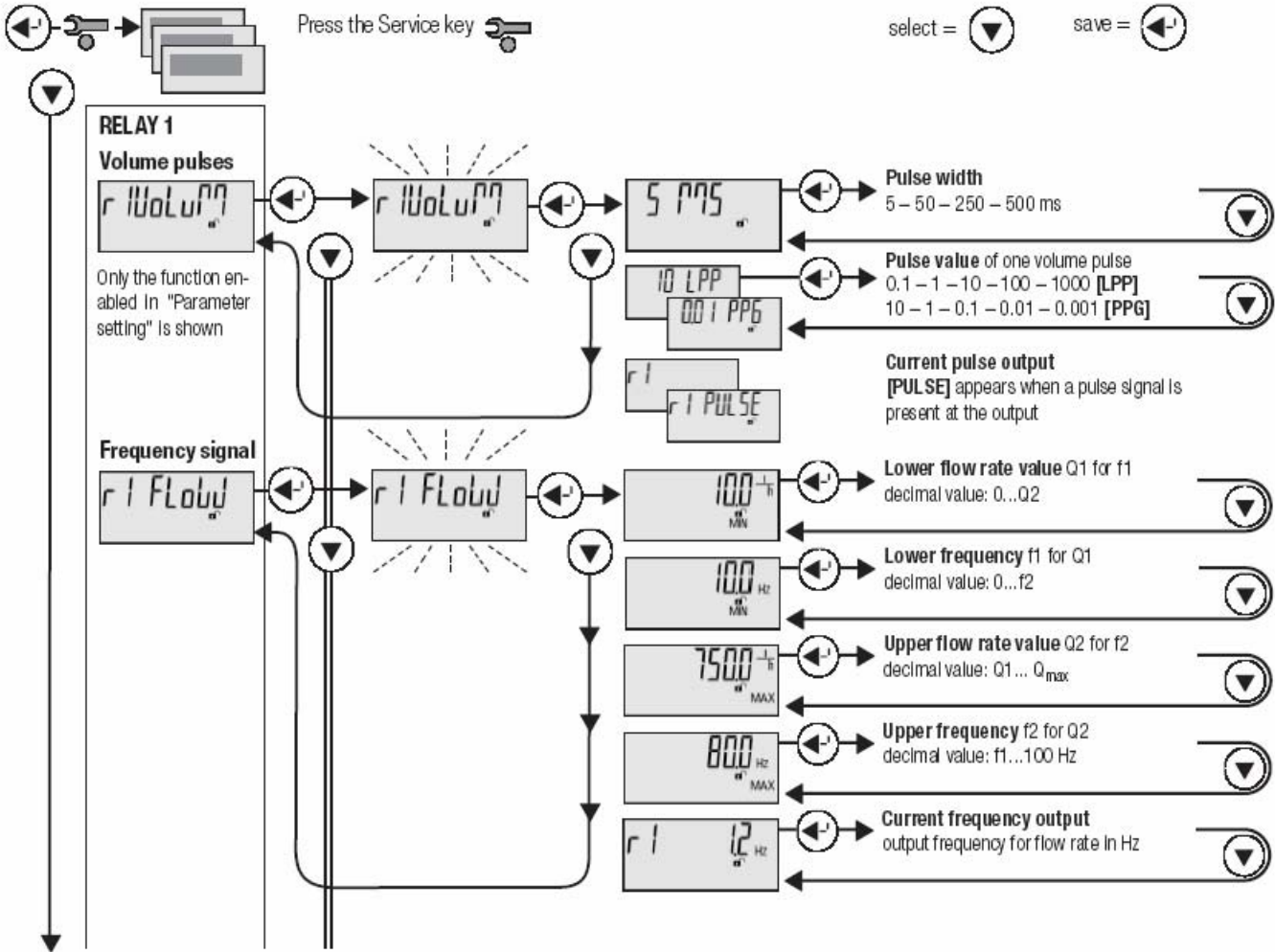

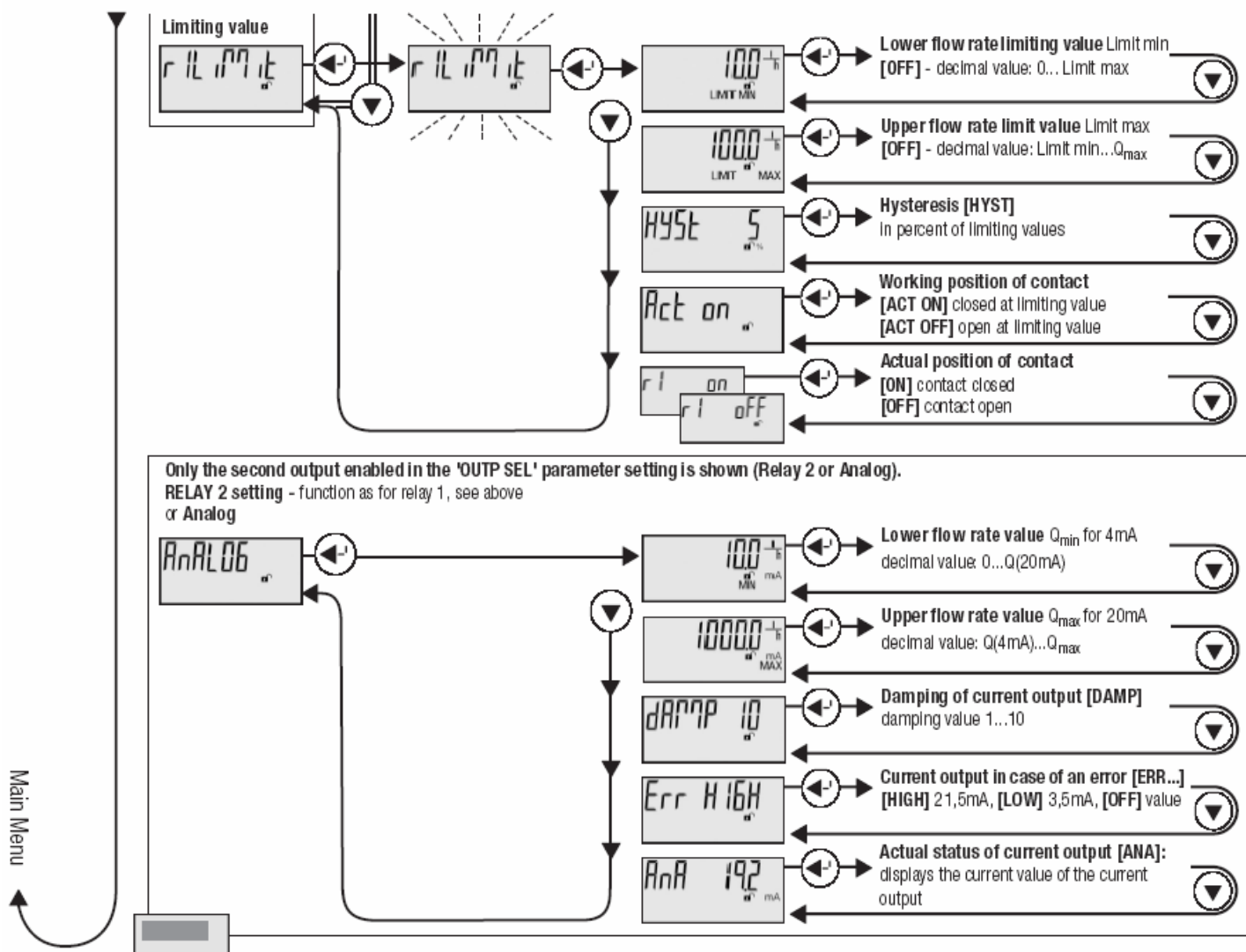

In order to set the individual parameters, the relevant menu item in the Parameter Menu must be found, as above. Press the Enter key to enable editing. The value to be set starts flashing and may be changed.

Selections are available for most of the menu items. Use the Step key to select a desired value and press the Enter key to save it. A saved value no longer flashes.

If discrete numerical values are to be entered as individual digits (e.g. flow rate values), proceed from the smallest decimal place to the largest. The digit to be set will flash. Use the Step key to select the value (0-9) and press the Enter key to accept. Then set the next higher decimal place.

The number of decimal places is fixed. For litres and gallons, one decimal place is specified; four decimal places are specified for m³.

For the limiting value settings, the function of the upper or lower limiting value switch can be disabled if necessary. To do this, an "OFF" selection is also offered when the lowest decimal value for the flow limit is entered.

If no key is pressed within 15 minutes, the device returns to the standard display and the Edit mode is discontinued. Any entries that have not been completed by pressing the Enter key are rejected.

14.2.3.2 Parameterising the display

In order to set the parameters, the device must be unlocked with the Service key. See the section on Parameter setting.

Setting the unit of measurement for volume [UNIT VOL]

Possible settings and subsequent parameters derived from them are as follows:

- litre [UNIT LIT]: pulse value in litres per pulse [LPP], flow in [l/time]
- cubic metres [UNIT M3]: pulse value in litres per pulse [LPP], flow in [m³/time]
- US gallons [UNIT USG]: pulse value in pulses per gallon [PPG], flow in [gal./time]

The set unit of measurement is shown as an index.

Setting the unit of measurement for time [UNIT TI]

Possible settings and subsequent parameters derived from them are as follows:

- hour [UNIT TI h]: flow rate in [Volume/h]
- minute [UNIT TI min]: flow rate in [Volume/min]

The set unit of measurement is shown as an index.

14.2.3.3 Parameterising the flow sensor data

In order to guarantee accurate measurement, the electronics on the flow sensor require adjustment. During calibration in the factory, the data for nominal size and the exact measuring chamber volume are entered for this purpose. These parameters cannot usually be changed again. They are displayed with the index [CAL] to document the calibrated condition of the instrument.

If the measurement transducer has to be replaced, it is possible to enter these two parameters manually in order to "marry" a new measurement transducer with the flow sensor. For spare parts for which the nominal size or measuring chamber volume can be changed, this is shown by the [UNCAL] index.

In order to set the parameters, the device must be unlocked with the Service key..

CAUTION: the settings for the nominal size or the measuring chamber volume can be changed within a maximum time window of 7 days after the first change, and a maximum of 4 changes can be made. After the time window has expired or after the fifth change to these two parameters, NO FURTHER CHANGES ARE POSSIBLE.

14.2.3.4 Parameterising the outputs

In order to set the parameters, the device must be unlocked with the Service key.

The outputs to be used must be enabled in the 'Output selection [OUTP SEL] in the Parameter Menu.

Only enabled outputs can be parameterised. The following alternatives are possible:

- 2 relay outputs (factory setting) or
- 1 relay output and 1 current output

Pulse output for summing the flow volume (totaliser)

Parameter Menu: volume function [R1VOLUM]

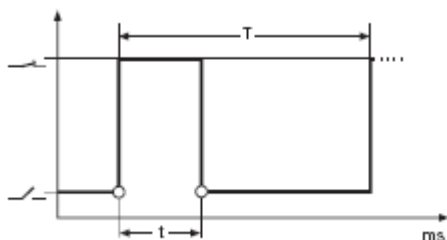

Parameters that can be set:

- Pulse width (t): 5 – 50 – 250 – 500 ms
=> The pulse width determines the smallest possible pulse value.
- Pulse value for litres, m³ [LPP]: 0,1 – 1 – 10 – 100 – 1000 m³ or Ltr/pulse
- Pulse value for US gallons [PPG]: 10 – 1 – 0.1 – 0.01 – 0.001 Pulses/USG
(Factory setting: 250 ms, 1 Ltr/pulse; DN40-50: 10 Ltr/pulse)
=> Based on the pulse width shown above, only those values are offered that can also display the maximum possible flow rate. If a lower pulse value is required other than those, a smaller pulse width must be selected.

Signal behaviour:

When the pulse value is reached, the solid state relay is closed for the duration of the set pulse width.

Frequency output depicting flow rate

Parameter Menu: flow rate function [R1 FLOW]

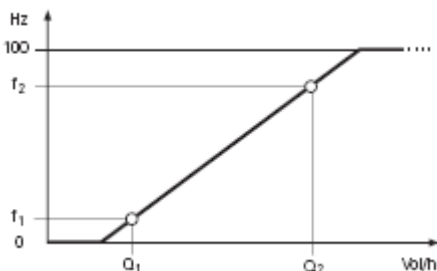

Parameters that can be set:

Frequency range and proportionality of the signal over the desired flow rate measurement range $Q_1 \dots Q_2$

- Lower flow rate [MIN]: $Q_1 \geq 0$ (factory setting: Q_{\min})
- Lower frequency [Hz]: $f_1 \geq 0$ (factory setting: 10 Hz)
- Upper flow rate [MAX]: $Q_2 \leq Q_{\max}$. (factory setting: Q_N)
- Upper frequency [Hz]: $f_2 \leq 100$ Hz (factory setting: 80 Hz)

=> The upper frequency must be larger than the lower frequency.

The upper flow rate value must be larger than the lower flow rate value.

Q_{\min} , Q_N and Q_{\max} are dependent on the nominal size of the meter.

Signal behaviour:

- a) Value falls below the set lower flow rate value Q_1 :
 - proportional decrease to 0 Hz, which is then maintained.
- b) Value exceeds set upper flow rate value Q_2 :
 - proportional increase to 100 Hz, which is then maintained.

No provision is made for error signals.

Switching output to signal a limiting value (Limit)

Parameter Menu: limiting value output [R1LIMIT]

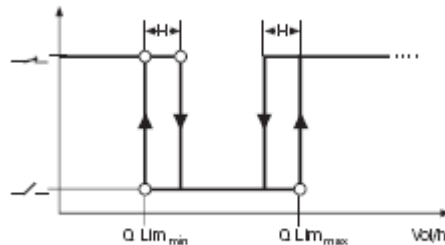

Parameters that can be set:

- Lower flow rate limiting value [LIMIT MIN]:
[OFF] or $Q \text{ Lim}_{\min} \geq 0$
(factory setting: Q_{\min})
 - Upper flow rate limiting value [LIMIT MAX]:
[OFF] or $Q \text{ Lim}_{\max} \leq Q_{\max}$.
(factory setting: Q_N)
- => The upper flow rate limiting value must be larger than the lower flow rate limiting value. Q_{\min} and Q_{\max} are dependent on the nominal size.
- Hysteresis [HYST] (H): 0...10% of Q Lim
(factory setting: 1%)

Working position of the semiconductor switch: active on – active off

Signal behaviour:

- a) For a flow rate lying between the lower and upper flow rate limiting values, the semiconductor switch is open in the "active on" working position. In the "active off" working position, it is closed.
- b) If the upper flow rate limiting value is reached or exceeded, the contact switches to the closed position. It switches back again as soon as the value falls below the upper flow rate limiting value by the hysteresis amount.
- c) If the lower flow rate limiting value is reached or if the value falls below this limit, the contact switches to the closed position. It switches back again as soon as the lower flow rate limiting value is exceeded by the amount of the hysteresis.

Analogue current output (4...20mA) depicting flow rate

Parameter Menu: analogue output [ANALOG]

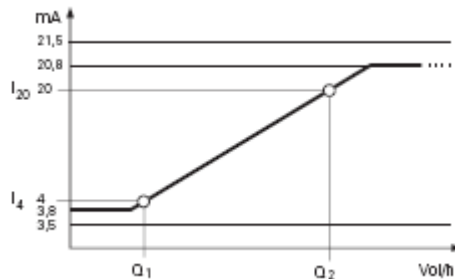

Parameters that can be set:

Proportionality of the signal over a flow rate-range Q_1 to Q_2

- flow rate at 4mA [MIN mA] (I_4): $Q_1 \geq 0$
(factory setting: 0)
- flow rate at 20mA [MAX mA] (I_{20}): $Q_2 \leq Q_{max}$.
(factory setting: Q_N)

=> The upper flow rate value must be larger than the lower flow rate value.

Q_{min} , Q_N and Q_{max} are dependent on the nominal size.

Damping of the signal on rapidly changing measured values

- Damping value [DAMP] 1 (none) ...10 (maximum)

=> The higher the damping, the larger the relative error.

Signal level when a relevant meter error occurs

Error behaviour [ERR ...]: HIGH (21,5mA),LOW (3,5mA), OFF

Signal behaviour:

- Value falls below the set lower flow rate value Q_1 :
 - proportional decrease to 3.8mA which is then maintained.
- Value exceeds set upper flow rate value Q_2 :
 - proportional increase to 20.8mA which is then maintained.
- Error signal for measurement-relevant meter error (sensor, ROM, supply voltage, etc.):
 - For HIGH error behaviour: output 21.5mA
 - For LOW error behaviour: output 3.5mA
 - For OFF error behaviour: no error signal, continued output of computed value.

14.3 Error messages

The electronics perform a self-test about every 5 minutes. If an error is detected which impairs the reliability or accuracy of the measurement, the [ERROR] warning will appear every 2 seconds on the display.

The error is shown in detail in the Information Menu:

- [E-FLOW] maximum permitted flow rate (Qmax) exceeded
The meter is mechanically overloaded and is no longer measuring accurately.
Action: reduce the flow rate or use the next higher nominal size.
- [E-POWER] supply voltage is too low
Faulty data processing, meter supplies incorrect measured values.
Action: check the voltage supply and eliminate the cause of the error (if applicable).
- [E-EEP] error when reading or saving data to EEPROM, faulty data backup.
Totaliser value may be incorrect.
Action: measurement transducer must be replaced. Please contact the supplier.
- [E-ROM] error when reading data from the ROM
Faulty data processing, meter supplies incorrect measured values.
Action: measurement transducer must be replaced. Please contact the supplier.
- [E-SENSOR] signal error from flow sensor to measurement transducer
Meter supplies incorrect measured values.
Action: measurement transducer must be replaced. Please contact the supplier.

14.4 Maintenance

Check connections periodically for tightness and if necessary tighten again.

For control and cleaning, the measuring chamber and the ring piston of the meters DN15 - 50 can be removed without dismantling the meter from the pipe.

The cleaning and revision cycle depends largely on the conditions of operation. Under favourable conditions 5 - 10 years suffice.

Check the units for corrosion. When ancillary equipment is used, observe their mounting and operation instructions.

Please, contact Auramarine Ltd for spare parts.

15 VISCOSITY SENSOR, TYPE VISCOSENSE2



Always use personal protective means when working with hot, aggressive and toxic process liquids.

Always use insulated tools when working on electrical installations.

The ViscoSense2 sensor body will heat up to the process temperature; do not touch instrument while process is running.

Never try to open the back of the sensor. This will damage the wire and sensor .

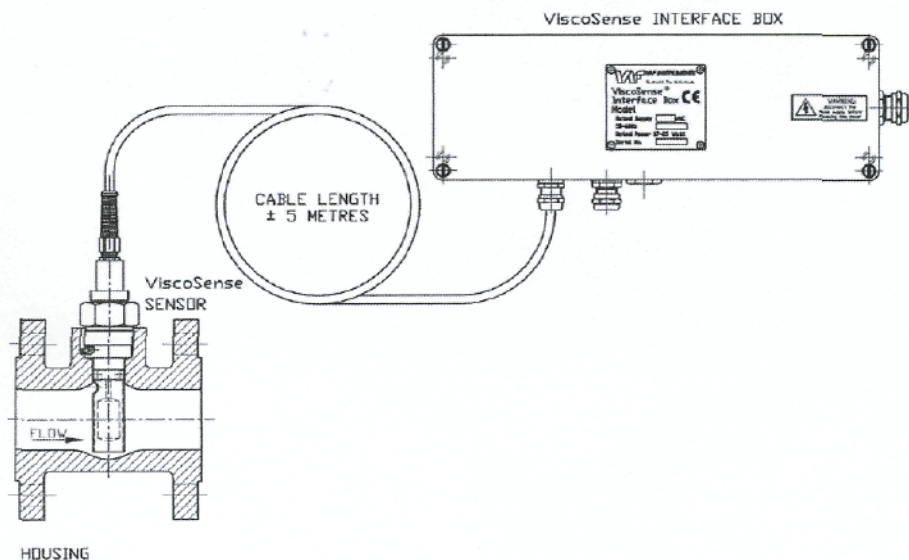

Fig 1 ViscoSense2 components

The sensor housing is made of ductile iron and has flanges for direct mounting in the fuel line. The sensor itself is made of stainless steel and is mounted in the housing. Two parts of the sensor, the pendulum and flowtube have a special teflon coating. It is supplied with 5 metres of signal cable for connection to the interface box.

The ViscoSense2 Interface box is a wall mount electronic unit, processing the signals from and to the sensor. It provides 4..20 mA signals for remote read-out of viscosity and temperature for a controller or other system elements.

The operating principle of the sensor is that of a torsion pendulum. The sensor consists of a stainless steel driver / sensor head (1), attached to the base plate (2) by means of a tubular torsion spring (3). In the head, one pair of piezo elements (driver piezos) (4) actuates the pendulum at its torsional resonance frequency, while another pair (the receiver piezos) probe the actual movement of the head. In a low viscosity medium, like air the resonance frequency is in the range of 1600 Hz. In a high viscosity medium the movement of the head is damped by the liquid. Consequently, the resonance frequency slightly shifts towards lower frequencies, whilst the width of the resonance peak increases, which is a measure for the viscosity. A flow tube (5) is placed around the pendulum, to protect it against mechanical damage. The flowtube inlet ensures a constant new supply of liquid for a correct measurement.

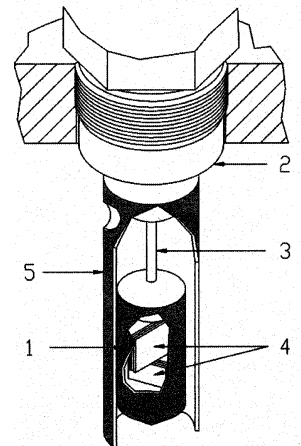

Fig 2 ViscoSense2 sensor

15.1 Operation

15.1.1 Initial start-up

1. Fill complete fuel system with diesel oil.
2. Open block valves (K and M) and bypass valve (L)
3. Allow diesel oil to enter the fuel system
4. Vent the fuel system.
5. Start the booster pump in the fuel system and after app 15 minutes close bypass valve (L)
6. Switch on power supply to the ViscoSense2 system.
Depending upon the viscosity of the liquid, it can take up to 30 seconds before the first reading appears. This is due to the automatic signal gain control.
7. Gradually change over to HFO.

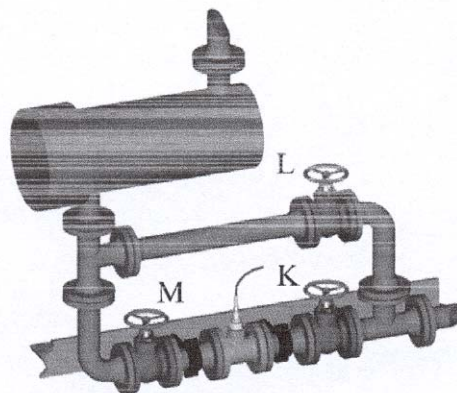

Fig 3

15.1.2 Routine start-up

Make sure that the power is on. No other special actions on the ViscoSense22 unit are required.

15.1.3 Shutdown on diesel oil

No special actions on the ViscoSense2 unit are required.

15.1.4 Shutdown on heavy fuel oil

Maintain heat tracing on the ViscoSense2 sensor housing after shutdown to prevent clogging of the fuel to the sensor internal parts.

15.2 Maintenance

15.2.1 Routine maintenance

Under normal conditions, the ViscoSense2 sensor requires no maintenance. "Normal" means;

- A clean operating environment
- ViscoSense2 interface box installed in accordance with the installation instructions given
- Operation accordance with manual
- Uninterrupted power supply at normal specified values

The flow should be in-between the maximum and minimum fluid flow rate. The ViscoSense2 housing should be placed in such a way, that no air can be trapped in the housing.

The fluid should be homogenous. It should not contain any air bubbles or foam. The fluid should not contain any chemicals or solid particals, that can damage teflon.

The ViscoSense2 sensor and interface box cannot be repaired onsite.They will be either exchanged for a spare unit or sent back to the manufacturer.

15.2.2 Cleaning



When removing the ViscoSense2 sensor from the piping system, precautions must be taken to prevent personal injuries and damage to the sensor and process installation.

General procedure

1. Change over to manual viscosity control
2. Shut off flow through the ViscoSense2 sensor by closing the valves on both sides of the sensor housing.
3. Switch off power supply to the ViscoSense2 interface box.
4. If possible, drain and empty the piping system.



Although the flow has been shut off, the ViscoSense2 sensor can still be hot and under pressure. Be careful when loosening flange bolts.

If the sensor is removed from a sensor housing which has not been de-pressurized, hot oil will spray out.

5. Unscrew the ViscoSense2 sensor from its housing by loosening nut (1, fig 4).
6. Take out the ViscoSense2 sensor.
7. **DO NOT REMOVE THE FLOW TUBE, DO NOT STICK ANY OBJECTS IN BETWEEN THE FLOW TUBE AND PENDULUM.**
8. Flush the space between the tube and the pendulum with diesel oil or non aggressive cleaning detergent.



Take care that the pendulum is not damaged or bent by mechanical force.

Do not use abrasive materials like sandpaper, files, etc. to clean the flow tube. This will damage the teflon coating.

15.2.2.1 Sensor assembly

1. Check the O-ring (2) before installing the ViscoSense2 sensor. Replace if necessary.

NOTE: Make sure not to damage the teflon coating during installation.

2. Carefully insert the ViscoSense2 sensor into the housing with the flow tube inlet facing the flow.

NOTE: Make sure the flow tube inlet is pointing towards the inlet of the sensor housing. If installed wrong, the sensor will not work correctly.

Check if the position of the hole inside the housing and the fixation pin on the sensor match.

3. Tighten the nut (1) by hand. If there is a temperature difference between the sensor and the housing, wait until they have the same temperature before tightening the nut.
4. Tighten the nut (1) with a wrench. Recommended torque is 100 Nm.



Make sure that all bolts and screws are tightened correctly before re-pressurising the system.

5. The ViscoSense2 system is now ready for operation.

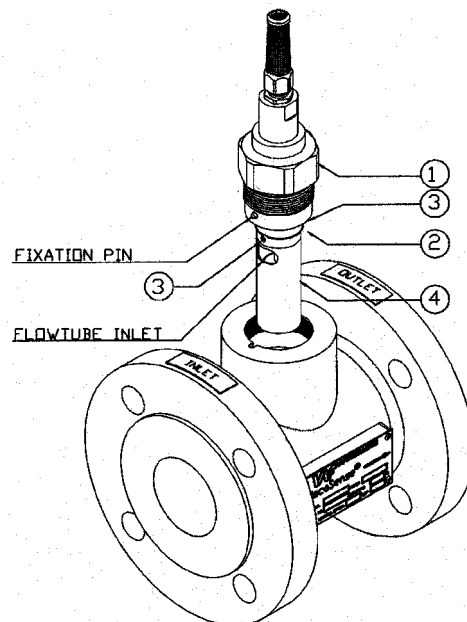
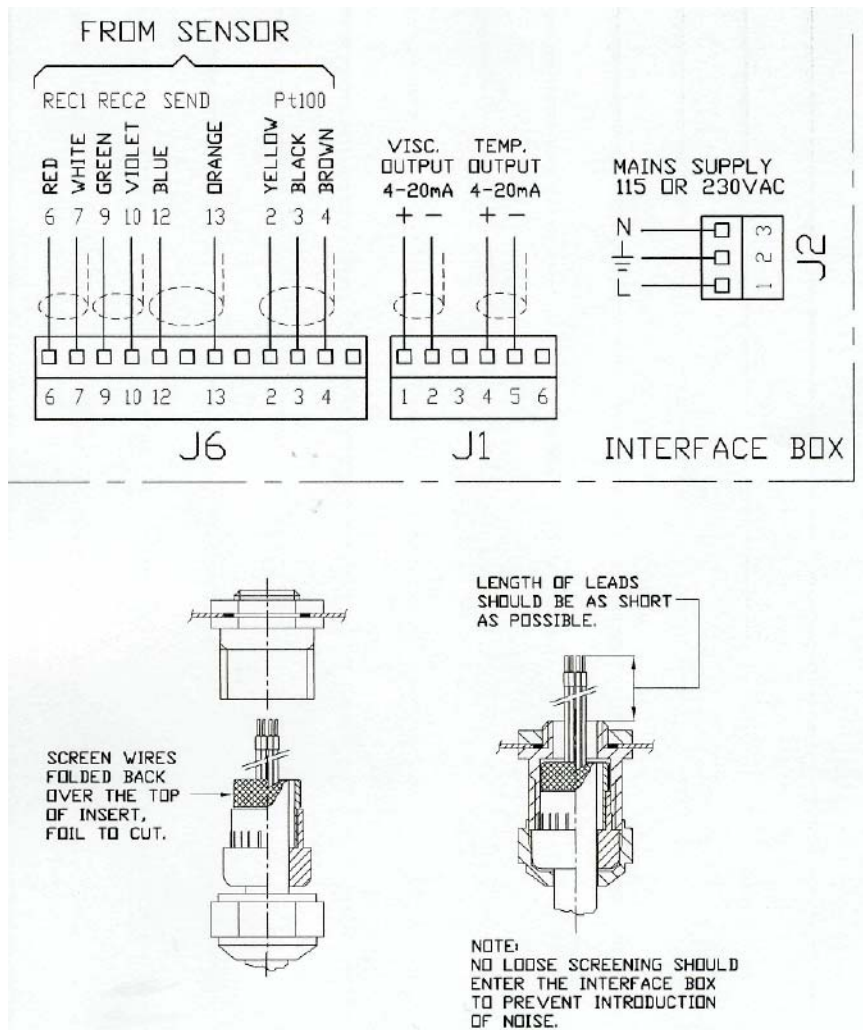

Fig 4 ViscoSense2 sensor assembly

15.2.3 Electrical connections



15.2.4 Trouble shooting and repair







The ViscoSense2 sensor and interface box cannot be repaired onsite. They will be either exchanged for a spare unit or sent back to the manufacturer.

When taking the interface box out of service, disconnect power to the box. The ViscoSense2 sensor should be taken out of the sensor housing and cleaned. To protect the pendulum from damage due to mechanical shocks, the transport locking cap should be carefully placed in between the flow tube and the pendulum. The sensor must be wrapped in protection material to protect it from damage. Both the sensor and the interface box must be stored in a cool and dry place.

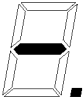
15.2.5 Diagnostic information

The printed circuit board inside the ViscoSense2 controller has a provision for diagnostic indication. Failures and errors are displayed by a blinking digit or character on a 7 segment LED. Dependent on the type of failure, error or warning, the viscosity and/or temperature outputs will go to 0, 4 or 20 mA, or will remain functioning normally.

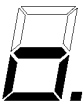
If there is no failure, error or warning, the display indicates the state of the program by displaying a symbol (not blinking) on the display. The following symbols are displayed during normal operation:

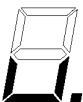
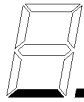
Display	Description	Display	Description
	Power on		Changing U-send setpoint
	Initialising hardware		Measuring at +45° (Left -3 dB point)
	VCO frequency measurement while phase is +45°		Measuring at -45° (Left +3 dB point)
	Waiting for U_receive to settle after changing setpoint		Adjusting phase

The decimal point at the bottom of the display is always on after power is on. This point is only turned off while the ViscoSense2 is writing to EEPROM and if no measurement is possible due to extensive external vibrations.





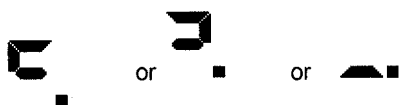

Normally the ViscoSense2 electronics will try to restart the unit if a faulty situation occurs. However, if the fault is persistent, contact Auramarine Ltd and give a detailed description of the problem that occurred and the diagnostic information indicated at the 7 Segment LED.

The faults indicated in the table below are listed in order of priority. The faults on top of the list have the highest priority. This means that faults with a lower priority can be overwritten by faults of a higher priority.

At power-on the system is explicitly tested for failures indicated by display messages 1, 2, 3, 4, 5, 6 and 7. During normal operation these tests (except 2) run at the background.



followed by

Display message	Viscosity output mA	Temperature output mA	Recovery action	Fault description
	0	0	Delay & retry	15 V power failure. Supply drops below 13 V
	0	Actual	Delay & retry	Pendulum not oscillating
	0	Actual	Delay & retry	Oscillation error
	4 4	20 4	None None	Temperature out of range (overflow) Temperature out of range (underflow)
	20 4	Actual Actual	None None	Viscosity out of range (overflow) Viscosity out of range (underflow)
	Actual Open loop	Open loop Actual	None None	Temperature output open loop Viscosity output open loop
Not all segments working after power on	Actual	Actual	Not applicable	7 - segment display defective

Any other figure or letter indicates an error in the electronics or software.

15.2.6 General trouble shooting

Problem	Possible cause	Corrective action
No viscosity signal	No supply to interface box	Check supply. Check fuses. Check electrical connections.
	Current loop connection broken	Check electrical wiring of 4-20 mA output signal
	Air entrapped in the fuel system	Vent the system
	ViscoSense2 malfunctioning	Check diagnostic led
No temperature signal	No supply to interface box	Check supply. Check fuses. Check electrical connections.
	Current loop connection broken	Check electrical wiring of 4-20 mA output signal
	ViscoSense2 malfunctioning	Check diagnostic led
Viscosity output is lower than expected	Actual viscosity is lower than expected. E.g. bunker calculator only gives approx. value. Dilution with MDO. Temperature is higher than expected.	None (For laboratory check of viscosity).
	Range settings ViscoSense2 and readout unit do not match	Check mA signal and range settings
	Air entrapped in the fuel system	Vent the system
Viscosity output is higher than expected	Actual viscosity is higher than expected. E.g. bunker calculator only gives approx. value. Temperature is lower than expected.	None (For laboratory check of viscosity).
	Range settings ViscoSense2 and readout unit do not match	Check mA signal and range settings
	Fuel is not pure, well mixed liquid	Vent the system
	Sensor is damaged or fouled	Clean and inspect the sensor

Viscosity output is max range	The viscosity in the sensor housing is higher than the max range	Heat up the fluid
	Actual viscosity is higher than expected. E.g. bunker calculator only gives app value	None
	ViscoSense2 interface box is malfunctioning	Check diagnostic led
	ViscoSense2 sensor is malfunctioning	
	Range settings ViscoSense2 and readout unit do not match	Check mA signal and range settings
	Sensor is damaged or fouled	Clean and inspect the sensor

15.2.7 PI setting errors (for additional viscosity controller)

The heater in the booster system are controlled by a viscosity controller. In order to get a good working viscosity system an optimum adaptation of the control parameters (P=proportional band Pb %), I=integral action time Ti min) is necessary.

Problem	Possible cause	Corrective action
Oscillating temperature with distinct initial overshoot	Pb too low	Increase Pb
Set point is reached very slowly after initial exceeding	Pb too high	Decrease Pb
The set value is reached very slowly without overshooting	Ti too high	Decrease Ti
High initial overshoot followed by fading oscillation	Ti too low	Increase Ti

15.2.8 Parts list

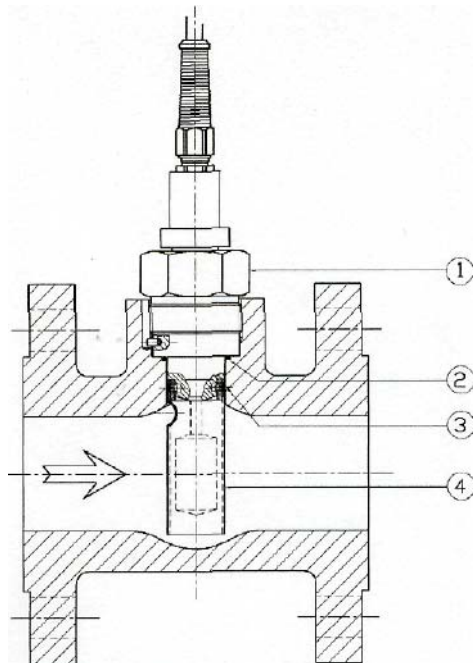

Ref. No	Qty	Part Number	Description & Material
1	1	0279-0096	ViscoSense2 sensor
2	1	0630-3022	O-ring, ID 25.12xØ 1.78mm
3	2	1743-0404	Hex. socket set screw M4x4 mm, DIN916
4	1	0342-0027	Flow tube

16 HEAT EXCHANGER, TYPE MX

16.1 General Description

Vesta MX heat exchangers are of the shell and tube type with u-bend tubes. All heaters have been hydrostatic pressure tested before delivery. Vesta MX heat exchangers have been type approved by all major classification societies.

16.2 Operation

16.2.1 Commissioning

Before start-up it is important to make sure that all connections are securely tightened. Before start-up it is equally important that the heater is filled 100% with liquid and that all connecting pipes are thoroughly air-vented.

NOTE: Remember to retighten the air ventilation plug.

16.2.2 Initial start-up



Fluid flow through the heat exchanger must be established before the heating medium is applied.

Operate the heater for one hour, stop, and retighten all screws.

16.2.3 Output

The output of the heater is subject to the supply of heating media at the inlet steam valve. The steam pressure/heating media temperature applied is to be according to heater size calculation. The output is furthermore subject to correct type of steam trap being used. Correct layout of the condensate system avoids negative effect of counter pressure.

16.2.4 Conservation during shut down periods

Corrosion occurrences in shut down periods are mainly caused by oxygen. The corrosion occurs if non-distilled or alkaline water remains in the heat exchanger. However, even when fully emptied, heaters are exposed to corrosion caused by water residues or condensation. Hence, heaters out of service should be protected against corrosion.

If the heater is out of service for an extended period of time – in particular during winter seasons with frost – it must be carefully emptied. Open the air escape valve and check for clogging.

16.3 Maintenance and cleaning



During disassembly, inspection, reassembly and testing it is important that all safety measures are observed.

The fluids in the systems can be both hot and flammable. Therefore it is important during disassembly and cleaning that proper depressurising, isolation and draining is performed, as well as spillage control. The mandatory pressure test is to be carried out with great care.

Insulation and splash guards must be fitted during recommissioning.

16.3.1 Regular cleaning periods

The heater should be cleaned regularly every six months by removing the tube insert, or at any time there is a decrease in output not related to other causes.

NOTE: The heat exchanger must be emptied before removing the tube section.

Check if any deposits have collected on the tubes.

16.3.2 Cleaning of tubes

Cleaning of the tube system from the outside is carried out after removing the tube insert using a sharp liquid jet (citric acid or water).

Cleaning of the tube system from the inside is carried out after removing the cover by flushing the tubes with e.g. citric acid.

16.3.3 Heavy contamination

If the heater is heavily contaminated with carbon deposits, the manufacturer recommends the heater chemically cleaned with a carbon remover.

After the cleaning has been completed, the heater must be flushed carefully with fresh water and allowed to dry afterwards.

16.3.4 Checking the safety valves

Once every year the safety valve must be checked for correct setpoint.

16.3.5 Dismantling and reassembling of the tube section

The tube section is inserted into the heater and fastened tightly between the shell flange and the end flange. The back end of the tube section is not fixed.

The primary connection for heating media must be dismantled before dismantling the tube section for inspection, cleaning, etc. The tube flange has threaded holes for dismantling screws and for mounting eyebolts for lifting devices.

Gasket surfaces are to be cleaned and protected against damage. New gaskets are to be fitted every time the flange connection has been dismantled.

NOTE: Fluid flow through the heat exchanger must be established before the heating medium is applied.

Tighten all main flange bolts according to below schedule. Operate the heater for one hour, stop, and retighten all bolts according to the table below.

NOTE: A pressure test should be carried out to prove tight joints.

Heater	No bolts	Size	Torque (Nm)	Tightening schedule
MX10	8	M16	50	1 4 7 2 5 8 3 6
MX15	8	M20	83	1 4 7 2 5 8 3 6
MX20	12	M20	79	1 7 11 4 9 2 6 12 5 10 3 8
MX25	12	M24	137	1 7 11 4 9 2 6 12 5 10 3 8
MX30	12	M24	186	1 7 11 4 9 2 6 12 5 10 3 8
MX40	16	M27	245	1 9 5 13 8 16 12 4 15 7 3 11 6 14 10 2

Heater main flange bolts tightening schedule (dry values) – T16 types

16.4 Spare parts

When ordering spare parts, please state the serial number of the heat exchanger (located on the nameplate). For spare parts and further information, please contact Auramarine Ltd.

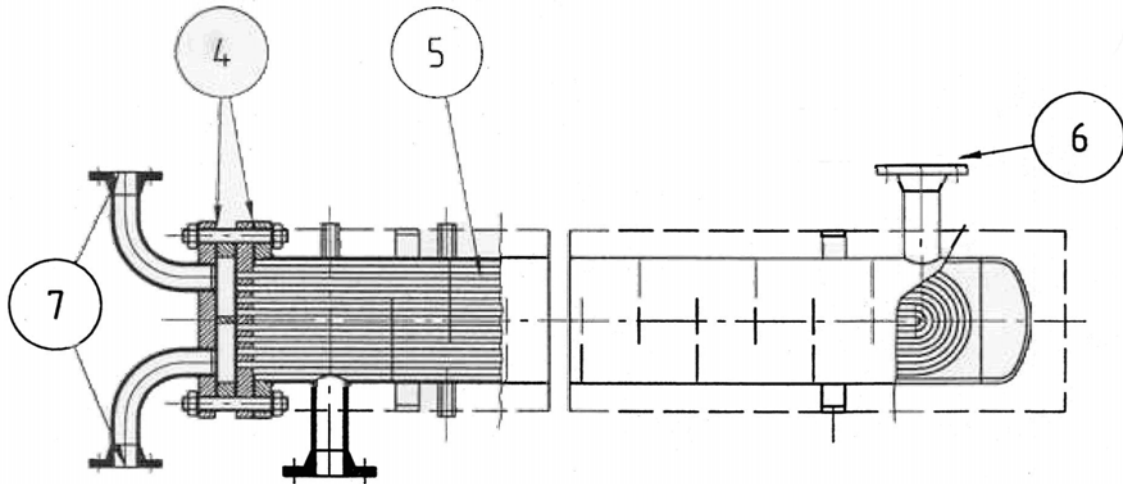

- 4 Flange gaskets
- 5 Tube insert
- 6 In and outlet flange gaskets
- 7 Steam and condensate flange gaskets

17 AC ELECTRIC INDUCTION MOTORS

17.1 Maintenance

Induction motors require very little maintenance. A regular regime of inspection is recommended to ensure minor problems do not escalate to break downs. Typical intervals would be 2000 hours of operation or 3 months, whichever is sooner.

Checklist:

- No visible damage ie fans cracked, fan cowls bent, foot cracked etc
- No accumulation of dust or fibres on the frame or around the fan inlet
- No significant corrosion of the lifting lugs/eyebolts
- No excessive vibration
- No loose fasteners
- Cables and earths are sound
- Sealing of the motor and gland plate in good condition
- Insulation resistance adequate, imperative this is checked after a prolonged shut-down

NOTE: Fumex smoke extraction motors should be rewound after 5 years of operation.
Regrease required, particularly large output 2 pole motors.
Bearing condition.

17.1.1 Periodic maintenance

- Remove the cover and the fan which is keyed, clamped, pinned or knurl located to the shaft extension.
- Loosen and remove bearing cover screws and end shield bolts/studs. The end shields should then be eased off their spigots. The rotor can now be carefully withdrawn from the stator, taking care not to damage the stator bore and both stator and rotor windings.

Having dismantled the motor, maintenance can be carried out to remove all dirt. For this purpose, the use of an air line supplying dry compressed air under comparatively low pressure is best, as a high velocity air-stream can force dirt into the spaces between the windings and insulation, etc.

Grease-removing solvents should only be used very sparingly to avoid damage to impregnating varnish or insulation.

Motors should be re-assembled in the reverse order from dismantling, remembering to ease end shields onto bearings and spigots. **Do not use force.**

Before starting, check that the rotor revolves freely. Ensure that the electrical connections are correct and terminal nuts tight.

17.1.2 Wound rotor

Brushes should be inspected every 1000 running hours or at three monthly intervals if this is a shorter period of time. The inspection should include checks for brush wear and tensioning.

Built up of carbon dust should be removed using a suitable dust extraction unit.

Replacement of brushes is recommended when the brush is approximately a quarter of the way down the brush holder. On calliper type designs the brushes should be replaced when 1/4" (5mm) of brush remains. It is important that the correct grade of brush is being used as this significantly affects operation.

17.1.3 Hazardous area motors

In addition to the conditions referred to, special requirements apply to motor types Ex N, Ex nA, EEx e, EEx d, EEx de. Refer to the approval certificate and appropriate codes of practice eg BS 5435.

17.2 Replacing non-drive end bearing

This instruction relates to W-DA100 - W-DA180 frames fitted with internal circlip.

17.2.1 Bearing removal

1. remove fan cover and fan.
2. remove Non-Drive End shield fixing bolts and withdraw Non-Drive End shield with rotor assembly from stator.
3. remove Non-Drive End oil seal levering with a screw driver.
4. remove bearing retaining external circlip from the shaft.
5. press shaft through and out of the bearing inner race, leaving the bearing inside the end shield.
6. experience shows that the bearing housing and circlip will not be damaged.
7. using reverse action circlip pliers, remove internal circlip from bearing housing.
8. bearing can easily be removed using hand tools bearing can easily be removed using hand tools.

17.2.2 Bearing replacement

1. place end shield on flat surface with inside facing upwards and insert the replacement bearing.
2. fit internal circlip. Note that the bevel on the circlip must be away from the bearing.
3. heat new end shield bearing assembly using bearing induction heater or hotplate type bearing heater.
4. push/press the end shield/bearing assembly onto the shaft, using the bearing inner race as an abutment, until the bearing is located against the shaft shoulder
5. allow to cool.
6. refit external circlip to secure bearing.
7. fit new oil seal with its open side facing outwards. Take care not to damage the oil seal lip.
8. reassemble motor.

17.3 Spare parts

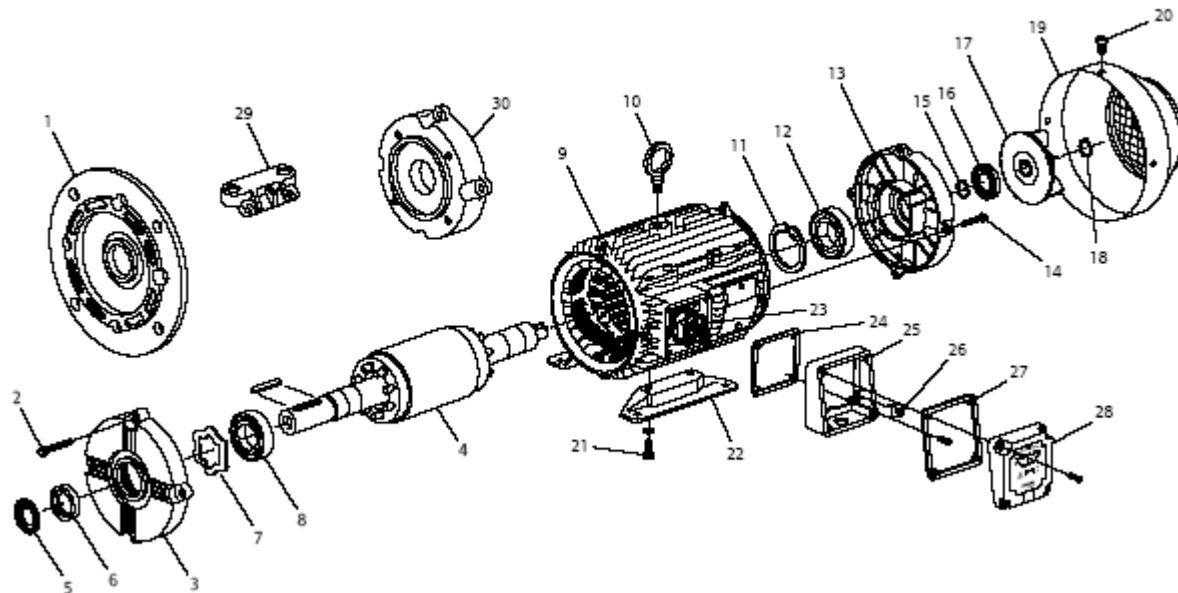

Aluminium construction Frame sizes DA63, W-DA71 to W-DA180*

1	Aluminium flange endshield, frames 100-132, cast iron flange frames 160-180	16	Non-drive end oil seal
2	Endshield fixing bolt	17	Fan
3	Drive end endshield	18	Fan circlip
4	Rotor assembly	19	Fan cover
5	Flinger	20	Fan cover screw and washer
6	Drive end oil seal	21	Foot fixing bolts and washer
7	Preload washer	22	Detachable feet
8	Drive end bearing	23	Terminal board
9	Stator assembly with or without feet	24	Terminal box to frame gasket
10	Eyebolt (when fitted)	25	Terminal box
11	Bearing retention circlip	26	Internal earth terminal
12	Non-drive end bearing	27	Terminal box lid gasket
13	Non-drive end endshield	28	Terminal box lid
14	Endshield fixing bolt	29	Pad mounting bracket
15	Bearing circlip	30	Face endshield

This drawing typifies the range W-DA100DW-DA180

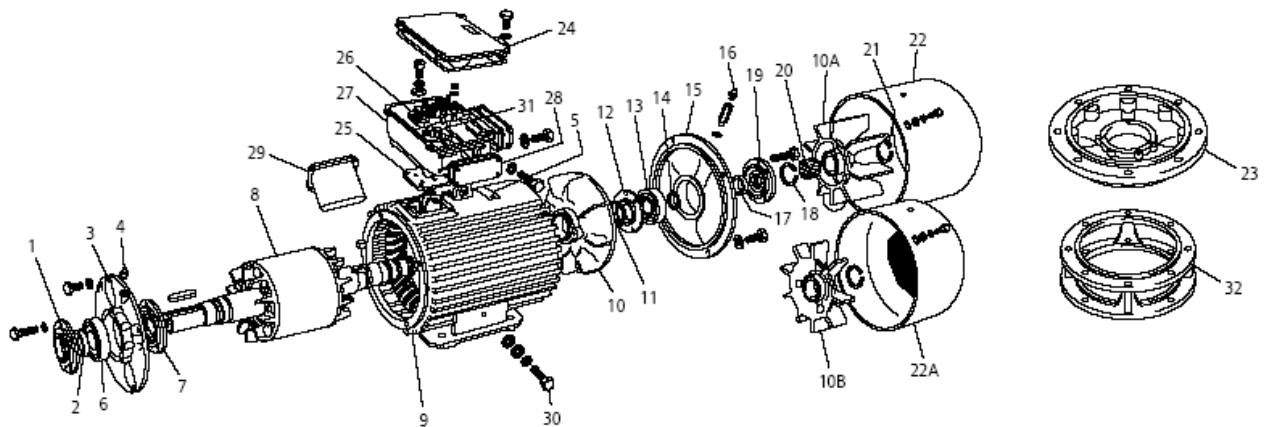

Steel construction, frame sizes 7-DS225 to 7-DS355

1	Drive end outer bearing cap	18	Fan circlip (replaced by shaft shoulder on some sizes)
2	Drive end oil seal (Labyrinth seals on Energy Efficient motors)	19	Non-drive end outer bearing cap
3	Drive end endshield (foot mounted)	20	Tolerance ring
4	Grease nipple	21	Fan circlip
5	Nameplate	22	Fan cover, for low noise option
6	Drive end bearing	22A	Fan cover
7	Drive end inner bearing cap	23	Flange endshield
8	Rotor assembly	24	Terminal box lid
9	Stator frame with feet	25	Terminal box gasket
10	Bi-directional internal fan	26	Terminal board
10A	Bi-directional external fan, for low noise option	27	Terminal box
10B	Bi-directional external fan	28	Detachable gland plate (frame sizes 225-250)
11	Fan circlip	29	Angled cable entry (frame sizes 280-355)
12	Non-drive end inner bearing cap	30	External earth terminal
13	Non-drive end bearing	31	Thermistor connection block
14	Non-drive end bearing circlip	32	Adaptor for skirt mounting
15	Non-drive end endshield		
16	Grease nipple and extension pipe		
17	Non-drive end oil seal (Labyrinth seals on Energy Efficient motors)		

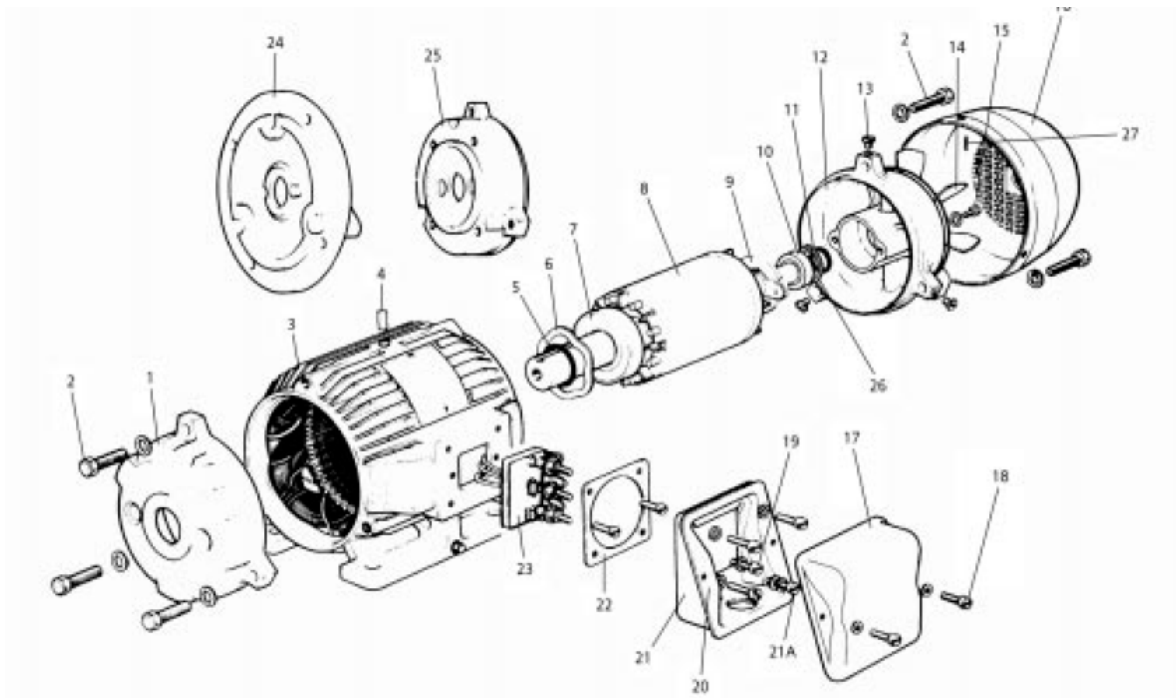

Cast iron construction, frame sizes DF80 to DF100

1	Drive end endshield	15	Non-drive end inner bearing cap screws
2	Endshield fixing bolts	16	Fan cover
3	Stator assembly with or without feet	17	Terminal box lid
4	Pack peg	18	Terminal box lid screws
5	Drive end oil seal (when fitted)	19	Internal earth terminal
6	Preload washer	20	Terminal box lid gasket
7	Drive end bearing	21	Terminal box
8	Rotor assembly	21A	Terminal box fixing screws
9	Non-drive end inner bearing cap	22	Terminal box to frame gasket
10	Non-drive end bearing	23	Terminal board
11	Non-drive end oil seal (when fitted)	24	Flange endshield
12	Non-drive end endshield	25	Face endshield
13	Fan cover screws and washer	26	Bearing circlip
14	Fan	27	Fan locating pin

18 SCREW PUMP, TYPE ACG GEN 8



If the pumps operating temperature exceeds 60°C, let the pump cool off before any service, maintenance or dismantling work is commenced to avoid burn injury.

All work carried out on the pump has to be performed in such a manner that risks for personal injury are observed!

When handling liquids that may harm skin, use gloves and/or protecting clothing!

When handling liquids which may involve fire hazard appropriate precautions to avoid danger are to be taken.

In case of failure for system with elevated pressure, fluid jets may cause injury and/or damage.

Oil leakage may make the floor slippery and cause personal injury.

Before any maintenance work, ensure that the driver is deenergized and the pump hydraulically isolated.

Connecting and disconnecting of electrical cables must be done only by personnel authorized to do such work.

In areas where permanent magnetic couplings are handled or stored with open access, persons with heart PACEMAKERS should keep a distance of 3 meters. For permanent magnetic couplings assembled within a pump a safety distance of 3 meter is sufficient.

Sectional view

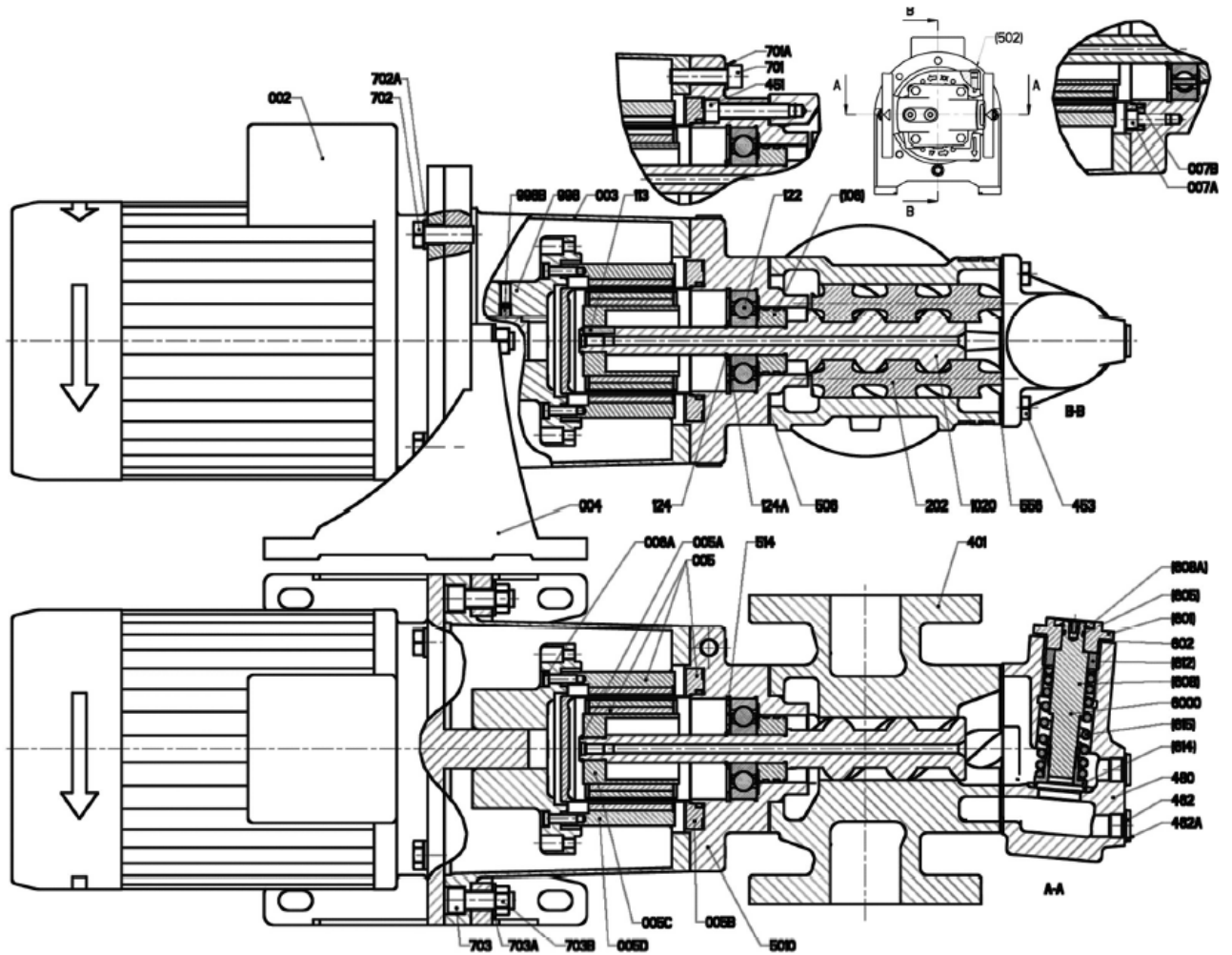

18.1 Start-up

After installation and whenever it can be assumed that the pump has been emptied, the pump must be thoroughly filled with liquid.

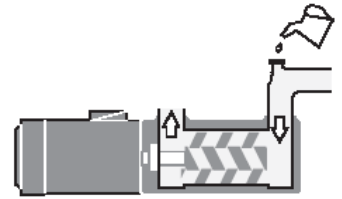

Make sure the prime mover is locked out and can not be started accidentally.

The system must be flushed and pressure tested before connecting the pump. If corrosive liquid, such as water is used, the system must be thoroughly drained, dried and protected against corrosion after having been flushed.

It is forbidden to use the ACG Optiline pump with fluids that contains more than 0,2% of air due to the risk of ignition during an eventual overheating of the pump.

18.1.1 Direction of rotation

When the pump is ready to be started, switch the motor briefly on and off and check that the drive motor rotates in the correct direction as indicated by the rotation arrow. The arrow is placed on the side of the front cover 5010 as well as on riveted steel plates on the connecting frame 003.

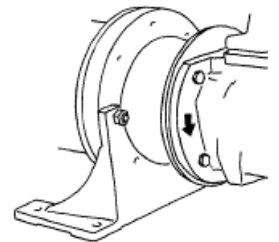

18.1.2 Differential pressure

Differential pressures below 1 bar is strictly forbidden as the magnetic coupling under these conditions may lose its cooling flow and cause an overheating of the magnetic coupling with a risk of a potential fire as a result. It is strongly recommended the magnetic coupled pumps to be equipped with a differential pressure monitoring device that stops the pump automatically if the differential pressure for some reason should drop to below 1 bar.

18.2 Maintenance

The intervals for inspection and replacement of wear parts vary greatly with the properties of the pumped liquid and can only be determined by experience. All internal parts of the ACG Optiline pump are lubricated by the pumped liquid. Pumping liquid which contain abrasive materials, or liquid that is corrosive, will significantly reduce service life and call for shorter service intervals. Wear in the pump will normally show as, vibration, noise, loss of capacity, reduction in flow/pressure or loss of the magnetic power.

Planned inspections are recommended and/or overhaul at regular intervals, not exceeding 5 years. It is recommended to always have the spares included in joint spare part kit G057 together with the ball bearing 122 available for a planned inspection.



Installations and maintenance must always take place during complete shutdown in an un-pressurised condition. The drive unit must be secured against inadvertent switching on by means of blocking the electrical supply to the electric motor in order to avoid serious injuries due to rotating parts.

18.2.1 Inspection of rotors

To reach the idler rotors in a quicker way than described in the dismantling section, loosen the rear cover (480) with the valve. Screw out the idler rotors backwards. Internal clearances in the pump, which are vital for its proper function, may have been affected by wear.

Acceptable wear can be determined only by experience of the actual application. As a rule of thumb the following max clearance values may apply:

- between rotor and bores: 0.2 mm
- between rotor flanks: 0.4 mm

For light duties (low pressure, medium viscosity) even bigger clearances may be acceptable but for low viscosity/high pressure duties the limit will be lower. Also watch if there are major scratches on these parts.

18.2.2 Inspection of the magnetic coupling

The magnetic coupling with all its components is considered to be maintenance free if operated and mounted according to instructions.

The lifetime of the magnets is well within the lifetime of the pump and exchange of the magnets is only necessary if a major breakdown has occurred as a result of for example excessive amounts of dirt or particles in the pumped fluid.

18.2.3 Common aspects whit magnetic couplings

Permanent magnetic couplings generate a strong magnetic field. The installation must be carried out only by trained staff that has the understanding of how a magnetic coupling acts and all the safety precautions related to it. All installation instructions must be strictly followed. Modifications or changes to the magnetic coupling or its components are not to be allowed under any circumstances. IMO does NOT take any responsibilities for damages caused by improper use or damages related to this.

Magnetic data carriers such as bank cards, floppy disks etc may become unreadable and should always be kept separated from the magnetic field.

Useful tools

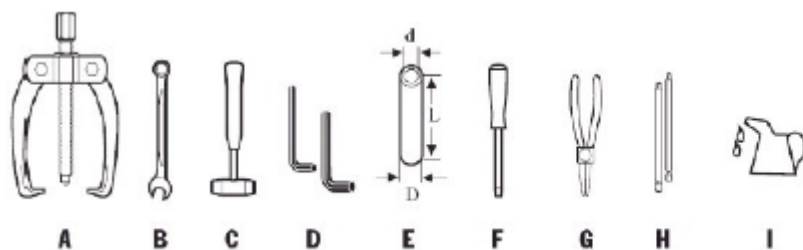

Mounting sleeve dimensions (mm)			
ACG size	d-min	D	L-min
045 - 052	21	32 ±3	110
060 - 070	36	50 ±3	145

18.2.4 Dismantling

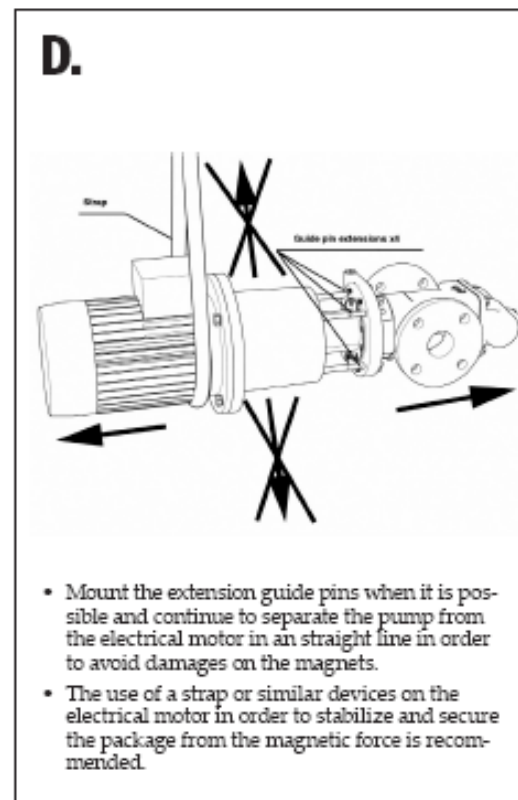
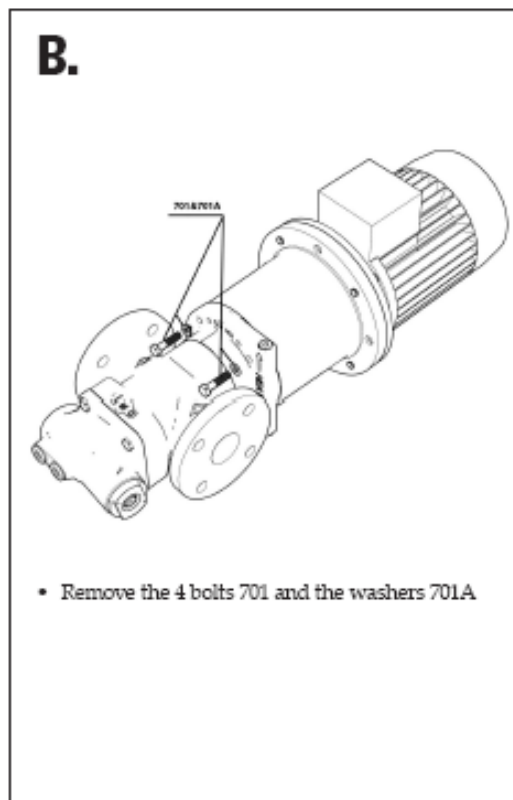
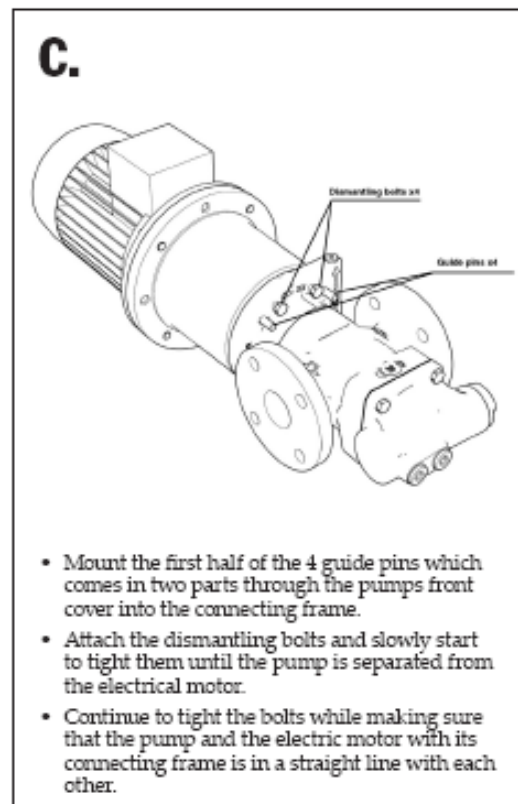
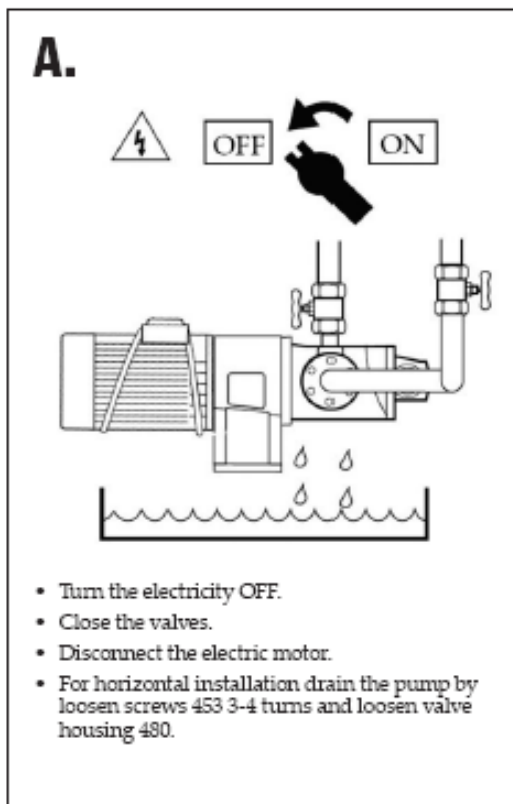

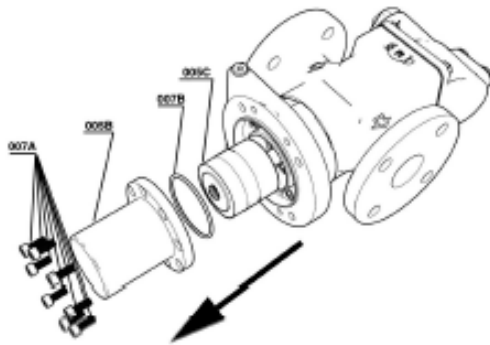
E.

- Unscrew the bolts 007A
- Pull out the sealing can 005B with its o-ring 007B

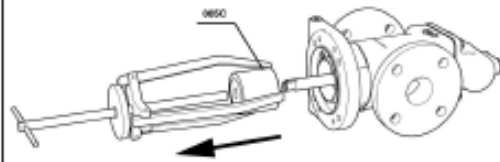
G.

- Remove the inner magnetic rotor with a suitable three arm puller

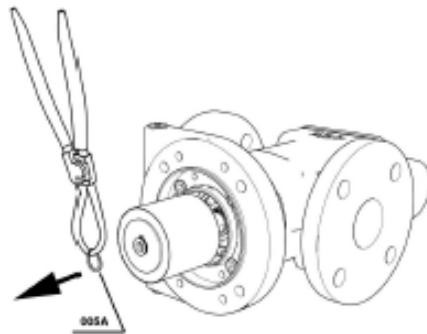
F.

- Remove the circlip 005A with a suitable plier.

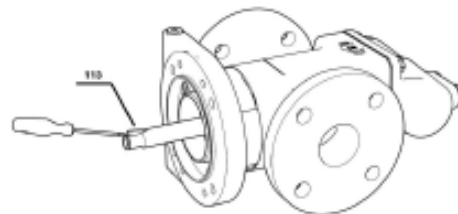
H.

- Remove the key 113 from the pump shaft.

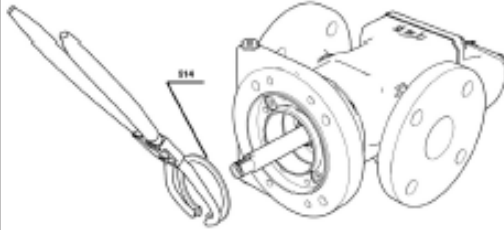
I.

- Remove the circlip 514 from the front cover with a suitable plier.

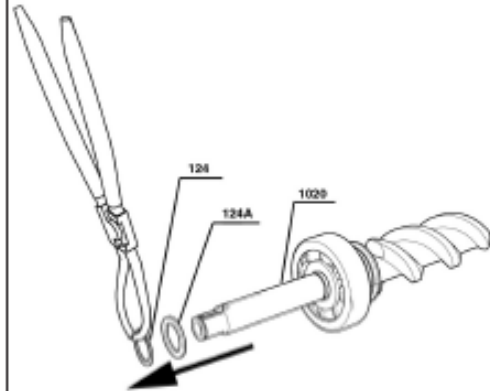
K.

- Remove the circlip 124 with a suitable plier from the power rotor 1020.
- Remove the support washer 124A.

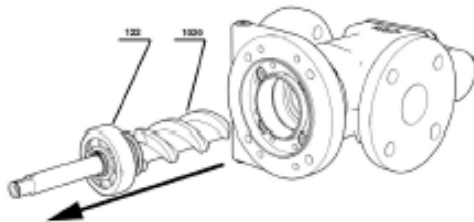
J.

- Pull out the power rotor 1020 with its ball bearing 122 by hand force from the pump body.

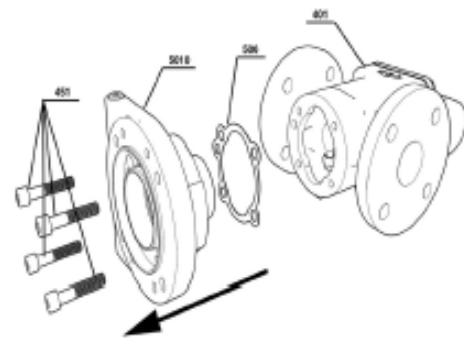
L.

- Unscrew the bolts 451 from the front cover 5010
- Separate the front cover 5010 with its gasket 506 from the pump house 401.

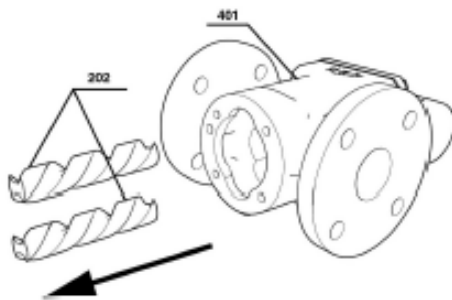
M.

- Pull out the idlers 202 from the pump body 401 by hand force.

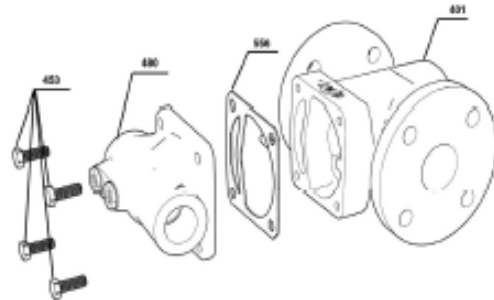
O.

- Unscrew the 4 bolts 453 with a suitable spanner and remove the rear cover 480 with its gasket 556 from the pump body 401

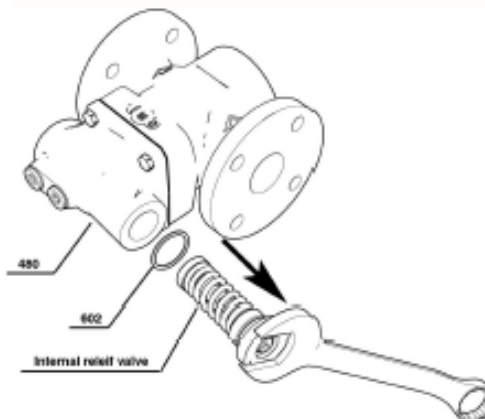
N.

- Unscrew the complete internal relief valve by means of a suitable open spanner and pull it out from the rear cover 480 together with its seal ring 602.

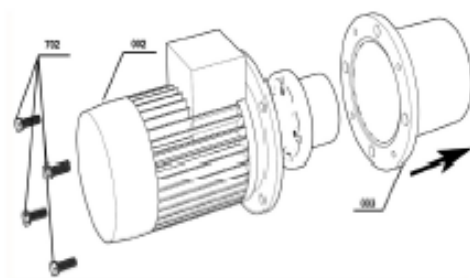
P.

- Unscrew the 4 bolts 702 with a suitable spanner and separate the connecting frame 003 from the electrical motor 002

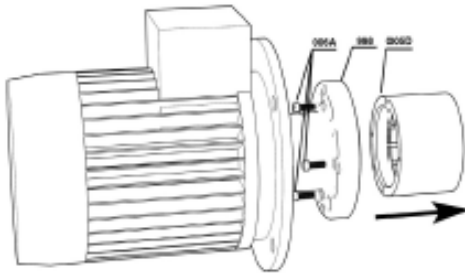
Q.

- Unscrew the bolts 006A with a suitable allen key and remove the outer magnet from the coupling 998

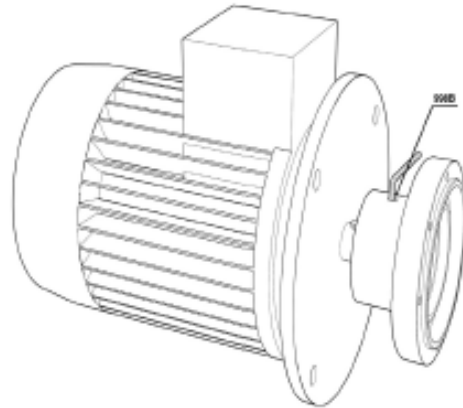
S.

- Unscrew the locking bolt 998B from the coupling 998.

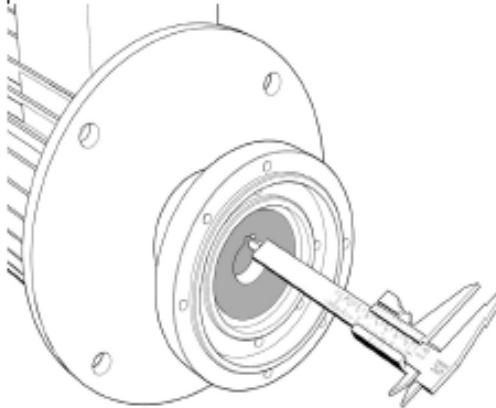
R.

- Measure the distance on the shaft coupling and note the value so that it can be used during the assembly later on.

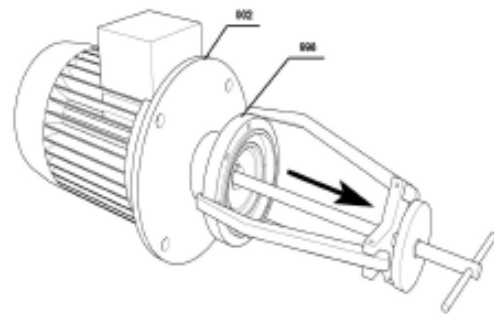
S.

- Use a three arm legged puller and remove the coupling 998 from the electrical motor.

18.2.5 Reassembly

A.

- Mount the coupling half 996 onto the drive shaft of the electrical motor by means of a big washer and a threaded pin and a nut that is tightened in order to press the coupling half onto the shaft.
NOTE: Do not use a hammer as this can Damage the shaft!

B.

- Measure the distance in order to get the same as before the coupling was removed.

C.

Pole pairs	Motor		Drive shaft		Magnetic coupling Arms				
	ST-no.	Ø Shaft (mm)	Designation	Ø1.06	Ø175-12-928A	Ø175-25-928C1	Ø175-38-928A4	Ø175-42-928A5	Ø175-48-928A6
Mounting distance h (±0.2 mm)									
90/45/2	100	28	Ø175-10/38	908A5	28	30	30	30	0
	110	28	Ø175-10/38	908A5	41	41	41	41	21
	130	38	Ø175-10/38	908A5	73	73	73	73	53
Ø60	100	28	Ø175-10/38	908A5	21	21	21	21	0
	110	28	Ø175-10/38	908A5	33	33	33	33	0
	130	38	Ø175-10/38	908A5	53	53	53	53	0
Ø70	100	28	Ø175-10/38	908A5	0	0	0	0	0
	110	28	Ø175-10/38	908A5	15	15	15	15	0
	130	38	Ø175-10/38	908A5	38	38	38	38	0
Ø80	110	28	Ø175-10/38	908A5	15	15	15	15	0
	130	38	Ø175-10/38	908A5	38	38	38	38	0

D.

- Tight the locking bolt 998B with a suitable hexagon key

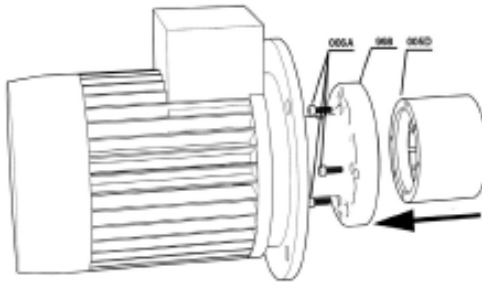
E.

- Attach the outer magnet rotor 005D to the coupling half 990 and tight the screws 006A according to the tightening torque table on page 17 in this manual.

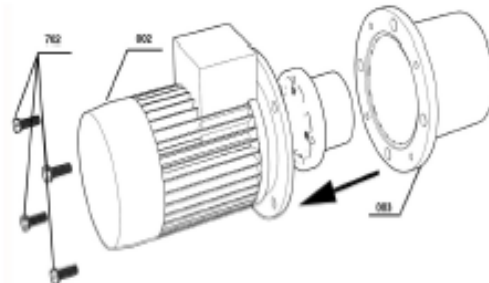
F.

- Attach the connecting frame 003 to the electrical motor 002 by means of tightening the bolts 702 according to the tightening torque table on page 17 in this manual.

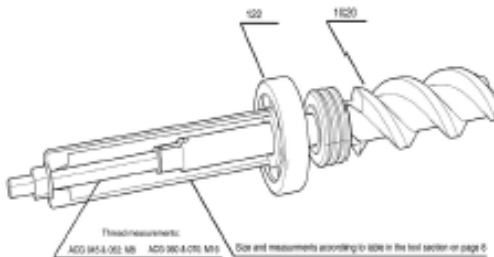
G.

- Mount the ball bearing 122 on the power rotor 1020 with the mounting tool described on page 8, use a threaded pin together with a nut and a washer and press down the ball bearing on the shaft carefully. Note: in order to make the ball bearing to slide on easier it is recommended to grease the shaft surface.

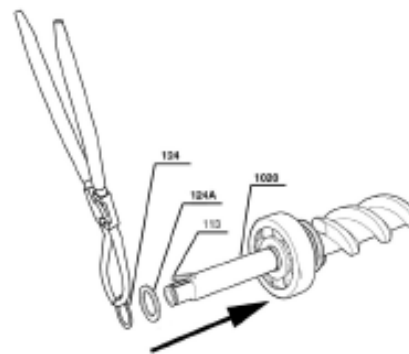
H.

- Mount the washer 124A and slide on the circlip 124 with a suitable plier on the power rotor 1020.
- Mount the key 113 on the power rotor 1020.

I.

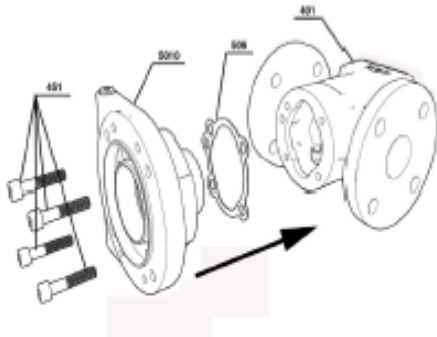

- Mount the front cover 5010 with its gasket 506 onto the pump body 401 with the bolts 451
- The bolts 451 are to be tightened according to the tightening torque table on page 17 in this manual.

J.

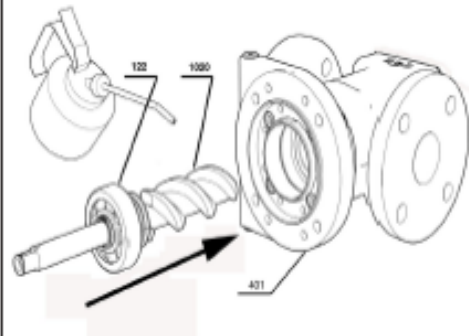

- Carefully slide the power rotor 1020 with its ball bearing 122 into the pump body 401 with hand force. Note: do not forget to lubricate the rotor prior to the mounting.

K.

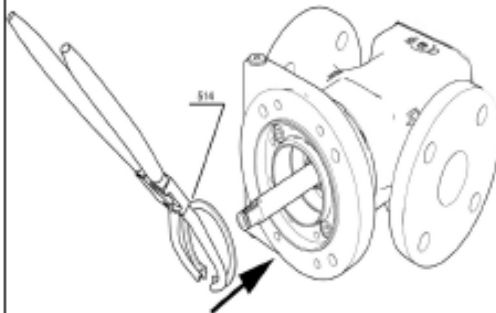

- Attach the Circlip 514 with a suitable plier into the front cover.

L.

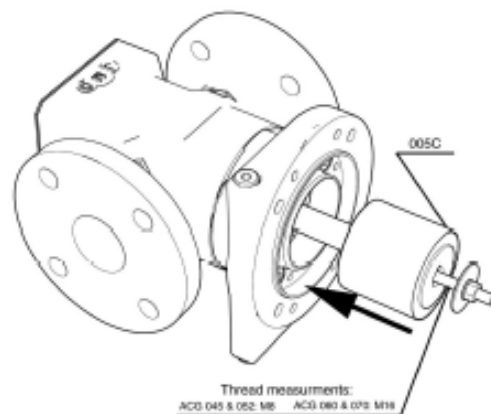

- Press the inner magnetic rotor onto the rotor shaft by means of a threaded pin and a nut/washer, push it into its final position by means of a suitable socket.

NOTE: DO NOT USE A HAMMER AS THIS CAN DAMAGE THE PARTS!

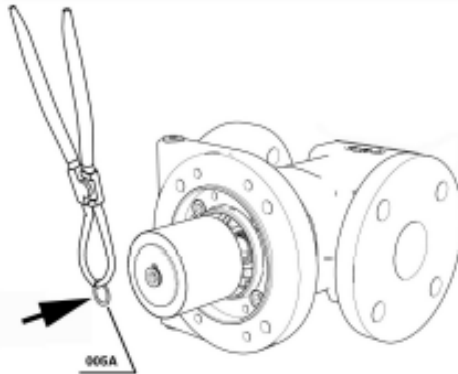
M.

- Mount the circlip 005A with a suitable plier.

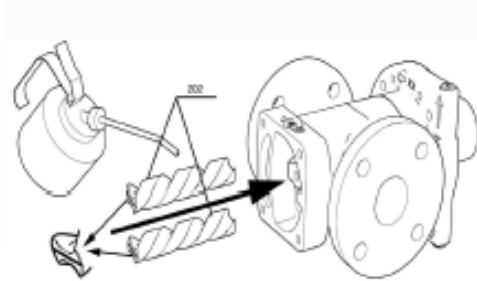
N.

- Carefully slide the lubricated idlers into the pump body
- Make sure that the lubrication slots are pointing backwards

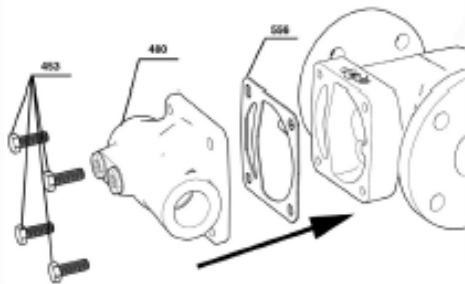
O.

- Mount the rear cover 480 with its gasket 556 onto the pump body and tight the bolts 453 according to the tightening torque table on page 17 in this manual.

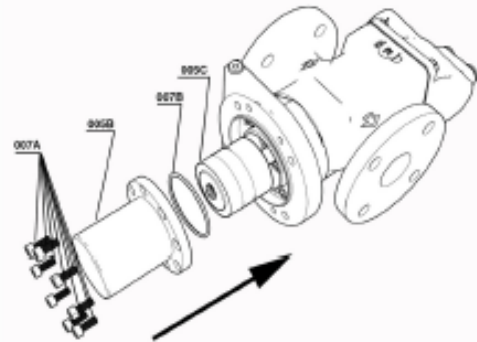
P.

- Mount the sealing can 005B with its o-ring 007A onto the pump and tight the bolts 007B according to the tightening torque table on page 17 in this manual.

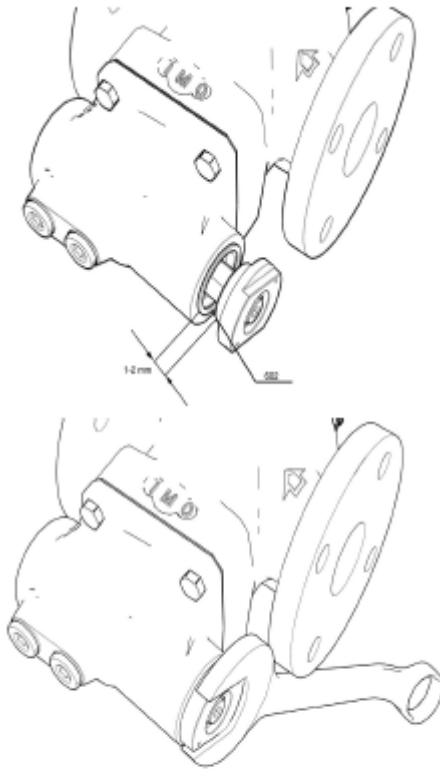
Q.

- Mount the pumps internal relief valve into the back cover by means of letting the inner threaded ring be mounted first with a distance to the outer one of 1-2 mm
- Do not forget to include the seal ring 602
- Tight the nut accordingly with a suitable spanner.

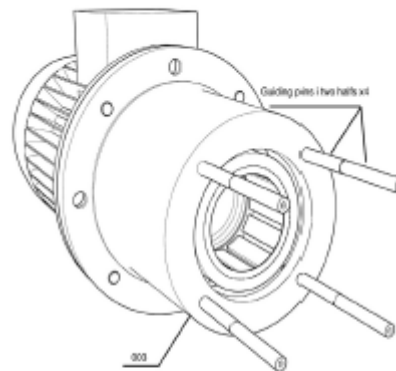
R.

- Mount the guiding pins into the connecting frame 003.

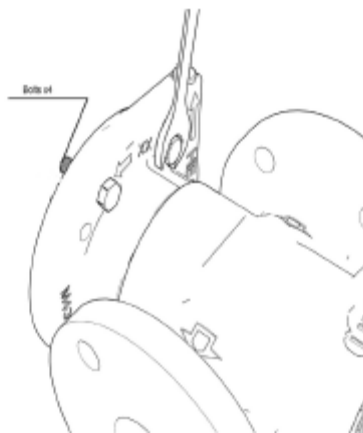
S.

- Attach 4 bolts in the pumps front cover in order to avoid a too rapid mounting due the magnetic forces that will take place when the pump package is joined.

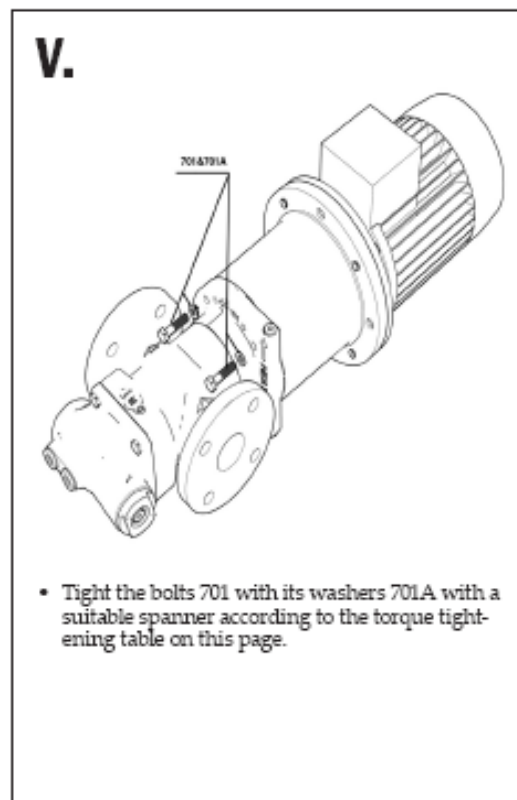
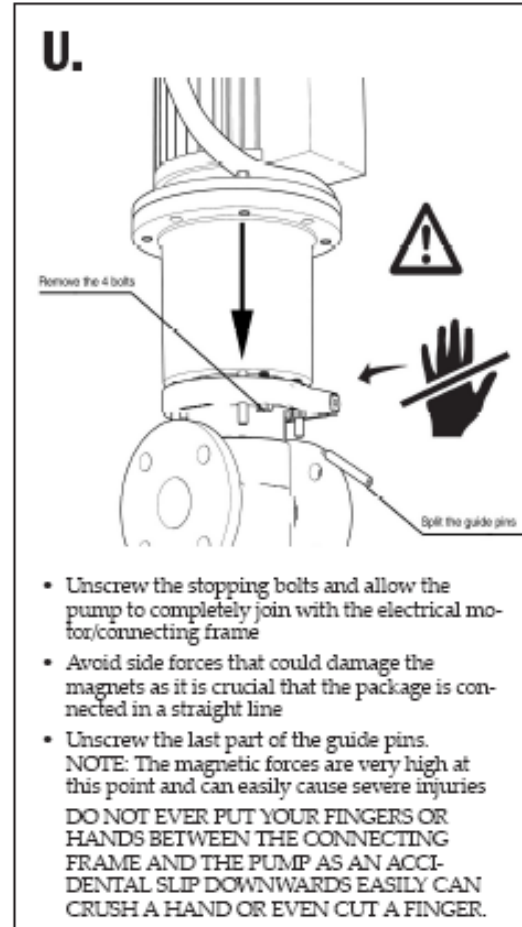
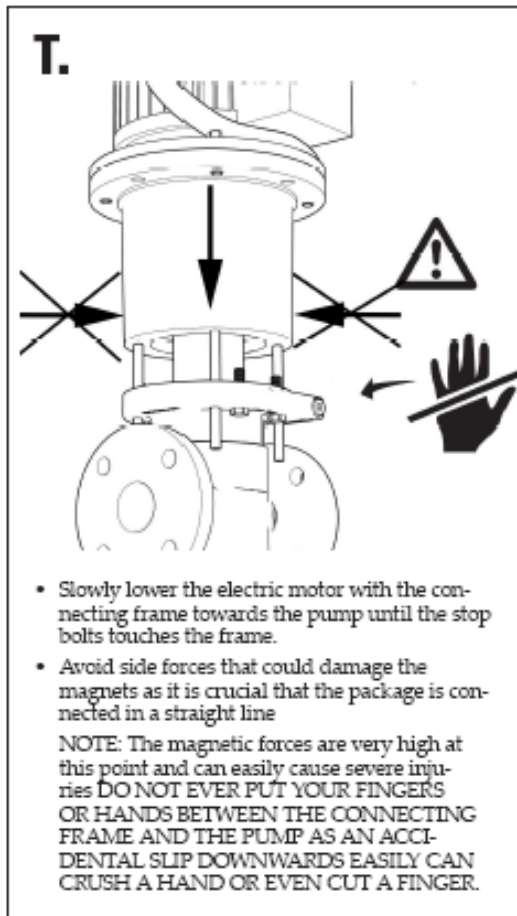

Tightening torques

Pos no,	sizes	045	052	060	070
006A		10	10	10	10
007A		20	20	20	20
451		47	47	81	81
453		47	47	81	61
462		74	74	74	74
502		47	47	47	47
301		13	20	47	47
702/IEC 100-132		30	30	30	30
702/IEC 160-225		74	74	74	74
703B/IEC 100-132		81	81	81	81
703B/IEC 160-225		197	197	197	197
998B		15	15	15	15

18.3 Spare parts

Valid for all ACG Optiline Generation 8 pumps with sizes 045, 052, 060 & 070 and leads K, N & D

With version codes NHBP, NJBP, NKBP, NLBP & NMBP.

Explanations:

G012: Rotor set

G054: G012+G057 +
pos. no 122

G057: Joint kit

G070: Valve element

G098: Magnetic cou-
pling

Pos No	Designation	Qty	Included components in Spare part sets				
			G012	G054	G057	G070	G098
002	Motor	1					
003	Connecting frame	1					
004	Angle bracket	1					
005	Magnetic coupling complete	1					x
005A	Retaining ring	1		x	x		x
005B	Sealing can	1					x
005C	Inner magnetic rotor	1					x
005D	Outer magnetic rotor	1					x
006A	Screw	4					
007A	Screw	6/8					
007B	O-ring	1		x	x		x
1020	Power rotor	1	x	x			
113	Shaft key	1	x	x			
122	Ball bearing	1		x			
124	Retaining ring	1		x	x		
124A	Support ring	1		x	x		
202	Idler rotor	2	x	x			
401	Pump body	1					
451	Screw	4/6					
453	Screw	4					
462	Plug	2					
462A	Sealing washer	2		x	x		
480	Valve housing	1					
5010	Front cover	1					
502	Plug	2					
506	Gasket	1		x	x		
514	Retaining ring	1		x	x		
556	Gasket	1		x	x		
601	Valve cover	1					x
602	Sealing washer	1		x	x	x	
605	O-ring	1		x	x	x	
608	Valve spindle	1					x
608A	Retaining ring	1					x
612	Regulating nut	1					x
614	Valve piston	1					x
615	Valve spring	1					x
701	Screw	4					
701A	Washer	4					
702	Screw	4					
702A	Washer	4					
703	Screw	3					
703B	Nut	3					
998	Drive hub	1					
998B	Screw	1					

18.3.1 Spare part and tool kits

Item	Spare Parts sets	Part numbers for pump size			
		045	052	060	070
G012	Rotor set D-lead				193023
	N-lead	193015	193017	193019	193021
	K-lead	193016	193018	193020	193022
G054	Major kit = G012+G057 + pos.no.122	-	-	-	-
G057	Joint kit	193031	193032	193033	193034
G070	Valve element	190990	190990	190984	190984
G098	Magnetic coupling H	193035	193035	-	-
	J	193036	193036	-	-
	K	193037	193037	193040	193043
	L	193038	193038	193041	193044
	M	193039	193039	193042	193045
122	Ball bearing	192855	192855	192827	192827
480	Valve housing	191022	191025	191028	191031

Kit	Contents	To be used for
G057	Gaskets, o-rings etc.	Dismantling of the pump
G012	Rotorset	Repair after major breakdown or great wear
122	Ball bearing	Repair after major breakdown or great wear
193128	Guide pins pump size 045	For dismantling and assembly of the pump
193129	Guide pins pump size 052	For dismantling and assembly of the pump
193130	Guide pins pump size 060	For dismantling and assembly of the pump
193131	Guide pins pump size 070	For dismantling and assembly of the pump

18.4 Trouble shooting

Problem	Cause	What to do
Wrong direction of rotation	- Electric cables to motor wrongly connected.	Reverse the terminal connection on electric motor. ATTENTION! Connecting and disconnecting of electric cables must be done only by personnel authorized to do such work.
The pump cannot be primed	- Wrong direction of rotation. - Suction line is not open or pressure drop in the suction line is too high. - Major air leakage into the suction line. - The pump cannot evacuate the air through the discharge line due to excessive counter pressure.	See above. Check all components in suction line. The inlet condition should be checked with a vacuum gauge at the pump inlet. Check the suction line. Check Deaeration
No flow	- The pump is not primed. - The pressure relief valve is set below the counter pressure.	See above. Readjust the pressure relief valve to a value above counter pressure.
Flow too low	- The pressure relief valve is set too low (Discharge pressure also low). - Something is restricting the flow in the suction line. (This would usually cause noise). - The pumped liquid contains a significant amount of compressible gas, such as free air. (This would usually cause noise).	Readjust the pressure relief valve Check all components in the suction line (strainers, valves etc.). See point Noise and vibration.
Pressure too low	- The pressure relief valve is set too low. - Counter pressure in the discharge line is too low due to a major leakage.	Readjust the pressure relief valve. Check the components in the discharge line inclusive the recipients.

	<ul style="list-style-type: none"> - The valve piston is stuck in open position. - Something is restricting the flow in the suction line. (This would usually cause noise). - The pumped liquid contains a significant amount of compressible gas, such as free air. (This would usually cause noise). - A too small pump has been chosen. 	<p>Check the valve. See Maintenance and Service instruction for respective pump.</p> <p>Check all components in the suction line (strainers, valves etc.).</p> <p>See point Noise and vibration.</p> <p>Contact Auramarine Ltd.</p>
<p>Pressure too high</p>	<ul style="list-style-type: none"> - The pressure relief valve is set too high. - The oil is too cold (or has higher viscosity than anticipated). - Counter pressure in the discharge line is too high. 	<p>Readjust the pressure relief valve.</p> <p>Reduce the pressure setting until operational temperature has been reached.</p> <p>Check the discharge line.</p>
<p>Drive motor difficult to start or tends to stop by tripping the motor overload relay</p>	<ul style="list-style-type: none"> - Counter pressure too high. - Liquid too cold. - Motor is undersized for the prevailing conditions. - Electrical power supply faulty. - Motor overload relay set too low or is faulty. - Incorrect setting of Y/D starter. 	<p>See above: Pressure too high.</p> <p>Readjust the pressure relief valve to a lower value. Thus the power consumption for the pumping is relieved and overloading due to the high viscosity may be avoided. When the liquid has reached normal temperature and thus flows easily, the relief valve is reset to normal pressure.</p> <p>Check the motor.</p> <p>Check the motor and motor connection.</p> <p>Readjust or replace the relay.</p> <p>Readjust the setting of the starting sequence. The time before the motoroverload relay is tripped should not exceed 10-15 seconds.</p>

<p>Noise and vibration</p> <p>ATTENTION! Monitor the pump function and shut down if any sign of malfunction is noticed</p>	<ul style="list-style-type: none"> - The flow to the pump is insufficient. - Insufficient support of pipe work. - Bad alignment - Air leakage into the suction line. - Free air in the liquid or gas cavitation. - Faulty electrical supply. 	<p>See point The flow is too low.</p> <p>Check for pipe vibrations in the pumpconnections. Check that the pipes are sufficiently clamped.</p> <p>Check alignment.</p> <p>Check the suction line for air leakage.</p> <p>For pumps with Tuning: Contact Auramarine Ltd.</p> <p>Check all three phases of the supply.</p>
---	--	---

19 BALL VALVE, TYPES N2, N8 AND N9

19.1 Operation



During operation the ball valves must be in either complete OPEN or CLOSED position in order to ensure their smooth and efficient working and long duration of seats. Leaving the ball in half open position could eventually cause damage to the soft seats.

19.1.1 Manual operation

The opening and closing of the valve is done by turning the handle a quarter turn (90°)

- a.) valve is in open position when the handle is in line with the valve and pipe line
- b.) valve is in closed position when the handle is across the pipe line

19.1.2 Automated operation

Valve can be automatically operated by: A pneumatic actuators (DA or SR), B hydraulic actuators, C electrical actuators, D gear box (manually operated). In this case no stop is fitted on the valve since it is normally a part of the actuator.

19.2 Maintenance

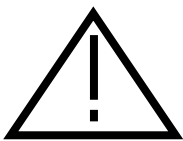

Before starting the maintenance, be sure that all pressure on the pipe is relieved.

Open and close the ball valve at least once to release the pressure completely also from the valve body.

- the ball valves if correctly used, normally do not need any internal lubrication and maintenance. However, when necessary, ball, or seats can be replaced only by relatively qualified personnel following the instruction of the manual without needs to use any machinery
- for further information about the recommended spare parts please check drawing and contact Auramarine Ltd.

19.2.1 Steam leakage

If leakage is evident on stem packing area, it can be eliminated by increasing the tightness of the lock nut 2B. In case leakage is still persisting the replacement of the stem packing 3 is recommended. For handle nut and lock nut (2A-2B) tightness see table.

19.2.2 Body seals leakage

Check for the tightness of the body bolts 16 according to table in case it is still leaking, it is necessary to replace the body seals 11-18.

19.2.3 In line or seats leakage

Check that valve is in fully closed position if so and the leakage is persisting the valve must be disassembled to replace damaged parts.



Safety precaution before removing the ball valve line for disassembly

- a.) **check that all pressure is exhausted from the line (upstream and downstream) and half open the ball to ensure that no pressure is trapped in the body cavity. In other words it must be drained of all fluid/gas and pressure.**
- b.) **remove the valve from the line and cycle valve at minimum 1 full cycle to ensure that any pressure trapped is released.**
- c.) **If the fluid in the line and into the valve is toxic, inflammable, corrosive or damaging for any other reason, it is advisable to take following precaution during the valve repairing:**
 - **use protective eye mask or glasses**
 - **use gloves, overalls and suitable footwear**
 - **ensure that running water and fire extinguisher is easily available at any moment**

19.3 Valve disassembly to inspect and/or replace body seals, seats, packing and ball

- a.) set the valve in open position and take out all body bolts 16 and complete body from end connections
- b.) close the ball and remove seats 10, ball 9 and body seals 11-18, be careful not to damage the ball
- c.) remove handle nut A2, name plate, handle 1, stop washer 17, lock nut 2B, spring washer 4, gland packing 6
- d.) push the stem 5 into the body 12. Remove packing rings 7 from body and O'ring 8 plus thrust washer 7 from stem.

19.4 Inspection and replacement

With the valve completely disassembled, clean and examine all the following components:

- a.) surface of the ball: any surface defect, particularly in the seating area will be extremely detrimental to the performance of the valve and therefore the ball should be replaced if found defective.
- b.) seats: replacement or seats is recommended
- c.) stem seals and body seals: also to be discarded and replaced by a new one
- d.) remaining components of the valve: after cleaning it is required a careful examination for wear, corrosion and mechanical damages particularly on threaded components. If components are found defective they should be replaced.

19.5 Re-assembly

Clean inside of body and stem housing. A light oil/grease compatible with line fluid can be used on ball, seats and stem surfaces.

19.5.1 Stem re-assembly

- a.) replace thrust washer and O'ring 7-8 and then insert the stem from the inside body
- b.) install the packing ring 3, gland packing 6, spring washer 4 and lock nut 2B and tighten. To avoid rotation of stem, apply temporarily the handle.
- c.) install stop washer 17, handle 1, name plate, handle nut 2A and tighten (see values given in the table)

19.5.2 Ball, seats and seals re-assembly, types N8 and N9

- a.) insert the fourth seat into the body and then insert the ball
- b.) insert the seat-retainer 23 together with the seat 10 and retainer-seal 18 and then repeat the operations on the opposite way. **ONLY NOW** you can assemble the n. 2 end-caps and tighten.
- c.) repeat the operations on the third way (third and fourth in case of 4 ways).

19.5.3 Ball, seats and seals re-assembly, type N2

- a) place the stem in closed position and insert the ball in the same position
- b) rotated in open position and then insert the seats and body seals
- c) insert the center-piece between the end-caps and tighten bolts and nuts firmly (see values given in table)

19.6 Testing

- a.) after having completed the re-assembly check for the manoeuvrability of the valve and make sure that ball rotates freely
- b.) if facilities are available, test the ball valve to the appropriate specification

19.7 Automated ball valves

- a.) if the valve is automated, reinstall the actuator and please note that the handle is not used. If necessary, reset the stops. First set- the valve in open position and check that ball is fully open. Second set- the valve in closed position and check, adjusting if necessary, for the best closure.
- b.) **CAUTION! Valves with electrical actuators should be tested starting from valve in: HALF OPEN - HALF CLOSED POSITION. This is to ensure that electrical connection is all right and rotation is correct. In case of wrong position switch off electrical actuator immediately and change the direction. Limit and torque switches are ineffective if rotation is wrong.**

19.8 Tightness values for handle nut 2A-2B and body bolts 16, types N8 and N9

VALVE SIZE		HANDLE NUT 2 A LOCK NUT 2 B			BODY BOLTS PART NO. 16		
FULL BORE	RED BORE	DIMENSION	NM	INCH LBS	DIMENSIO N	NM	INCH LBS
1/4	/	M 10X1	8	70	M8X17	35	310
3/8	1/2	M 10X1	8	70	M8X17	35	310
1/2	3/4	M 10X1	8	70	M8X17	35	310
3/4	1	M 12X1.25	15	130	M10X22	50	440
1	1 1/4	M 12X1.25	15	130	M10X22	50	440
1 1/4	1 1/2	M15X1.5	25	220	M12X30	70	620
1 1/2	2	M15X1.5	25	220	M12X30	70	620
2	2 1/2	M15X1.5	25	220	M12X30	70	620
2 1/2	3	M22X1.5	40	355	M12X35	70	620
3	4	M24X2	50	440	M12X35	70	620

19.9 Tightness values for handle nut 2A-2B and body bolts 16, type N2

VALVE SIZE		HANDLE NUT 2 A LOCK NUT 2 B			BODY BOLTS PART NO. 16 AND NUTS PART NO 19		
FULL BORE	RED BORE	DIMENSION	NM	INCH LBS	DIMENSIO N	NM	INCH LBS
1/4	/	M 10X1	8	70	M8X47	35	310
3/8	1/2	M 10X1	8	70	M8X47	35	310
1/2	3/4	M 10X1	8	70	M8X51	35	310
3/4	1	M 12X1.25	15	130	M10X64	50	440
1	1 1/4	M 12X1.25	15	130	M10X75	50	440
1 1/4	1 1/2	M15X1.5	25	220	M12X88	70	620
1 1/2	2	M15X1.5	25	220	M12X95	70	620

19.10 Storage

Valves to be stored for a long time shall be checked by the quality control personnel every 6 months; every 3 months when valves are actuated.

Maintenance during storage period:

- a.) internal surface must be inspected to check complete dust or other foreign parts absence
- b.) old rust or any dust must be removed by wiping with proper solvent
- c.) after cleaning, ball valves must be lubricated by using an adequate lubricant
- d.) ball valves must be operated for a least 2 complete cycles

19.11 Spare parts

N8 and N9

Item NO	Q.TY	PART NAME
1	1	Handle
**2a	1	Handle nut
**2b	1	Lock nut
*3	1	Packing ring
**4	2	Spring washer
**5	1	Antistatic stem
6	1	Gland packing
*7	1	Thrust washer
*8	1	O-ring stem
**9	1	Ball
*10	4	Seats
*11	3-4	Body seal
12	1	Body
13	3-4	End connections
14	1	Stop-pin
16	16-20	Bolts
**17	1	Stop washer
*18	3-4	Retainer seal
23	3-4	Seat retainer

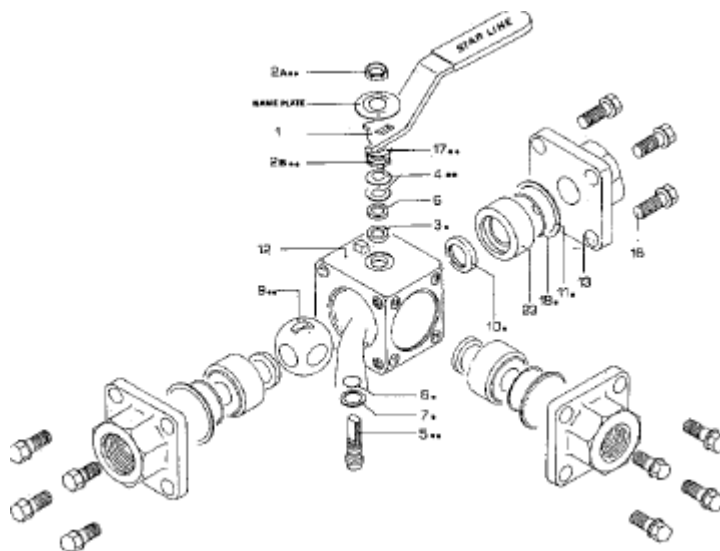

N2

Item NO	Q.TY	PART NAME
1	1	Handle
**2a	2	Nut
*3	1	Packing ring
**4	2	Spring washer
**5	1	Antistatic stem
6	1	Gland packing
*7	1	Thrust washer
*8	1	O-ring stem
**9	1	Ball
*10	2	Seats
*11	2	Body seal
12	1	Body
13	2	End connections
14	1	Stop-pin
16	4	Bolts
**17	1	Stop washer
*18	2	Body seal
19	4	Nuts

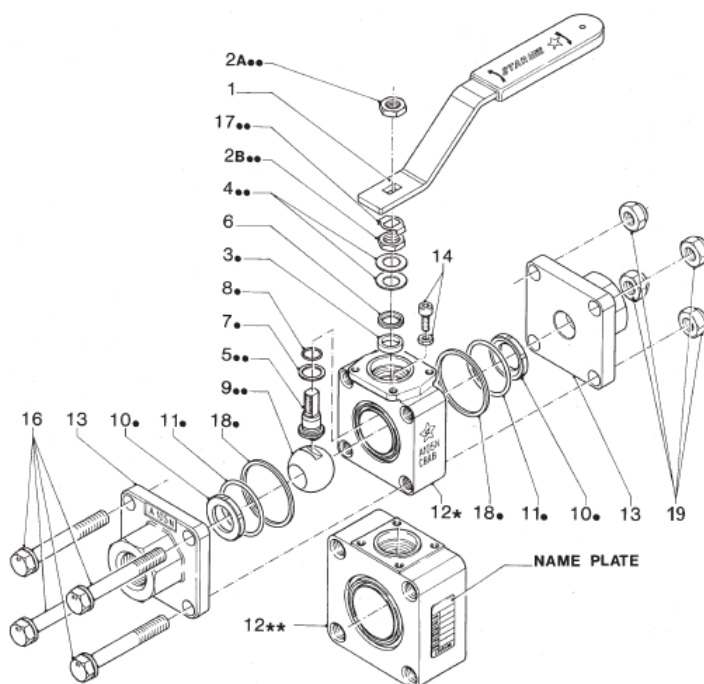

* suggested materials after 2 years service
** suggested materials after 5 years service

20 CONTROL VALVE, TYPES BR440-446



Before putting a new plant into operation or restarting a plant after repairs or modification, always make sure that:

- **All installation and assembly work has been completed!**
- **The personnel is qualified**
- **The valve is in the correct position for its function!**
- **Existing guards have been attached and in good order.**

20.1 Maintenance

Maintenance and maintenance intervals have to be defined by the operator according to the service conditions (see TRB 700).

When dismantling the valve the following points must be observed beside the general principals rules and TRB 700 governing the assembly work:

- pipe system must be pressureless
- medium must be cool
- plant must be drained
- piping system is purged in case of aggressive or caustic media
- the assembly work is performed only by qualified personnel

20.1.1 Packings with PTFE V-ring unit

PTFE V-ring unit consists of 1 backing ring, 4 sealing rings, 1 cover ring

Owing to the installed compression spring, this spindle packing is self-adjusting. If the spindle starts leaking, the ring pack is worn out and must be replaced.

Replacing the PTFE V-rings:

- Remove the actuator (see operating instructions for actuator).
- When replacing PTFE V-ring unit (12), make sure that the parts are installed in the correct order and positions.
- Damaged spindles must also be replaced (see chapter Replacing the plug, spindle and seating for instructions) since a new ring pack will soon start leaking again with a damaged spindle.

NOTE: Gasket (17) must be replaced.

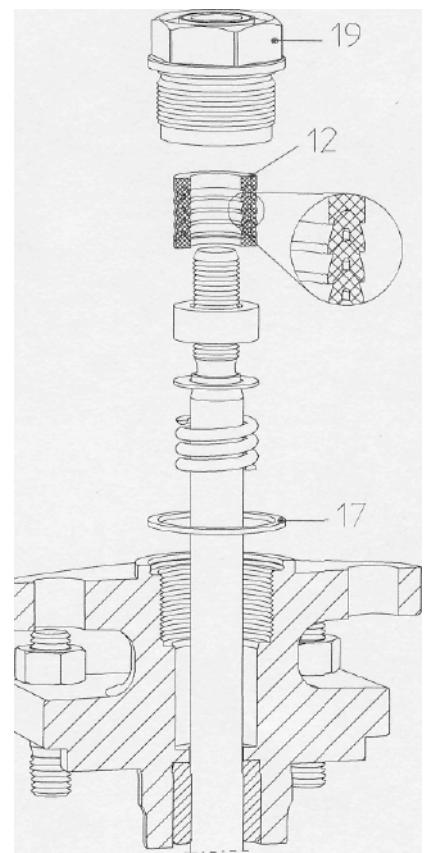
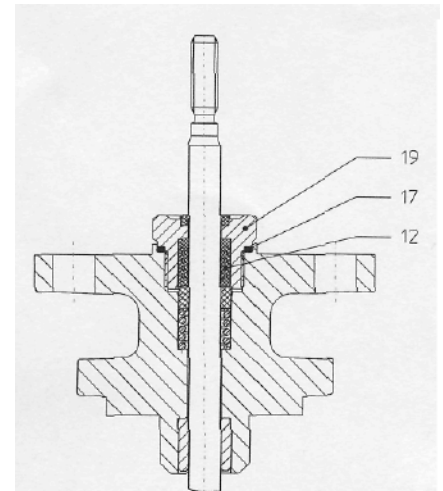

20.1.2 Stuffing box packings

Stuffing box packings require maintenance. If leaks develop, immediately tighten the screw joint (25) gradually until the packing stops leaking. The service life of stuffing box packings (23) can be increased by checking regularly leakage. If leaks can no longer be stopped by tightening the nuts, a new packing ring must be inserted into the gland.

Replacing a stuffing box packing:

- Insert the new packing ring
- If a split packing ring is used, cut with a chamfer
- Damaged spindles must also be replaced since a new ring pack will soon start leaking again with a damaged spindle.

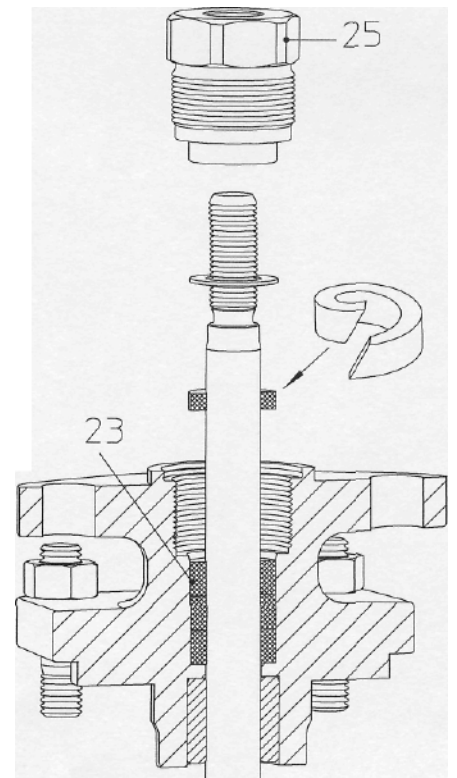
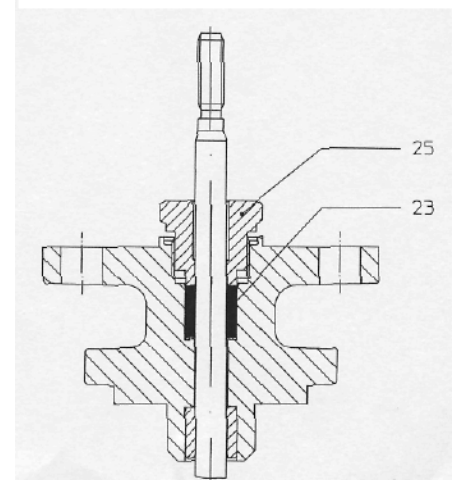

20.1.3 Bellow Seal

If the spindle leaks, the bellow seal is defective. The leak can initially be stopped by tightening the screw joint (20.17).

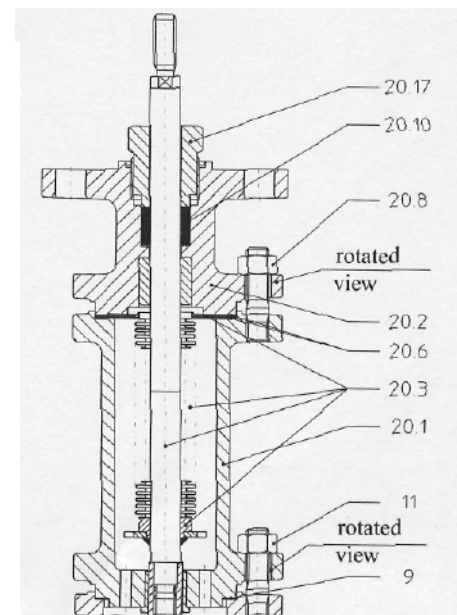

Replacing the bellow seal:

- Remove the actuator (see operating instructions for actuator).
- Slacken the screw joint (20.17) by about one turn.
- Remove the bellows housing by unscrewing the nuts (11).
- Remove the plug
- Detach the mounting bonnet (20.2) after unscrewing the nuts (20.8).
- Extract the spindle from the bellows housing.
- Drill new spindle with plug.
- Replace 2 seals (20.6) and 1 seal (9).
- Assemble in the reverse order. Screw on the nuts (11, 20.8) and tighten them crosswise (The spindle can only be replaced complete with bellows.)

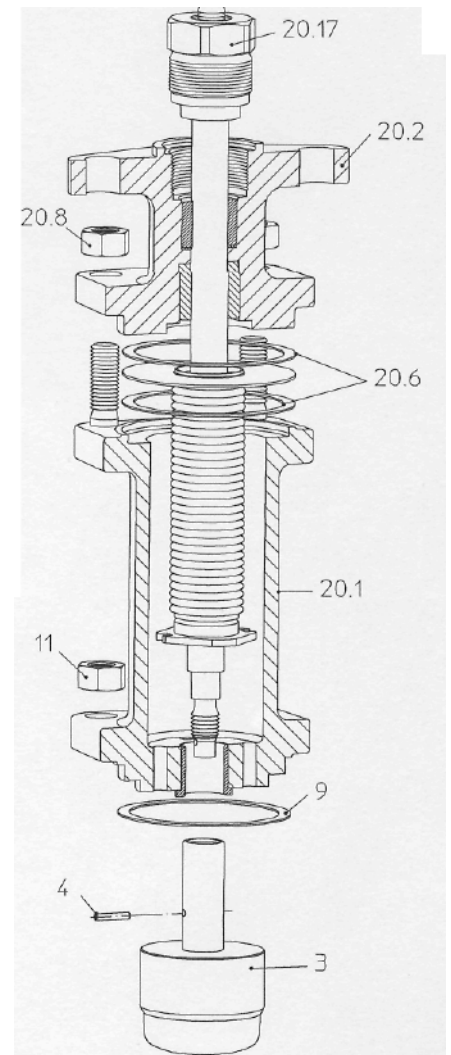

20.1.4 Replacing the Plug, Spindle and Seating

- Remove the actuator (see operating instructions for actuator)

a) Control valves

- Detach the mounting bonnet (7).
- Slacken screw joint (19) by about one turn.
- Extract and replace the plug with spindle.
- Replace the gasket (9).
- Set the mounting bonnet cover in place and secure it with nuts (11) tightened crosswise.

Plug and spindle can only be replaced completely.

b) Control Valves with Bellow Seal

- Unscrew the nuts (11).
- Remove the bellows housing (20.1) with plug (3).
- Keep the spindle pressed down.
- Remove the clamping sleeve (4).
- Unscrew the plug (3).
- Fit the new plug in the reverse order.
- Drill the plug and insert new pin.

The spindle can only be replaced complete with bellows

c) Replacing the Seating Ring (only Fig. 55.445 and Fig. 55.446)

The seating ring is screwed into the valve body and can be unscrewed for replacement or remachining. A special wrench is needed to remove the seating. It can be obtained from the manufacturer.

When fitting a new or reconditioned seating, clean thread and sealing taper in body and apply suitable lubricant.

See below for scat ring tightening torque's.

DN 15/20	100 Nm
DN 25/32	150 Nm
DN 40/50	350 Nm
DN65	480 Nm
DN80	660 Nm
DN100	980 Nm

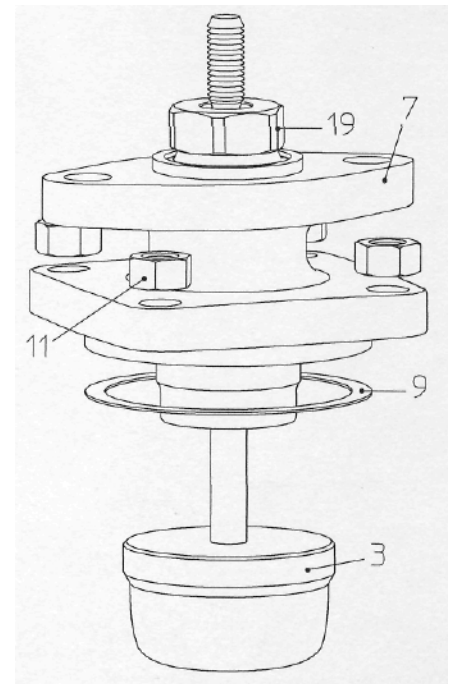

d) Pressure-balanced Plug

Replacing the Seals

- Detach valve top part and remove plug (replace if necessary).
- Prise worn piston seal (32) out of groove in plug with suitable tool (e.g. screwdriver).
- Insert new piston seal, taking care that it is in the correct position
- Replace guide ring (31).
- Clean sliding surface of guide bush (30); smooth with fine abrasive if necessary.
- Before assembly, remember that two seals (9) must be replaced.
- Set valve top part in place.
- Tighten the hexagon nuts of the cover gradually crosswise.

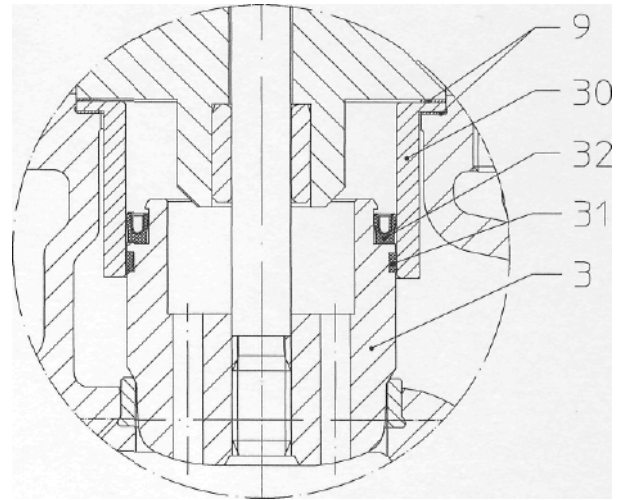

Tightening torque for hexagon nuts:

Bolts	Torque
M10	20 Nm
M12	35 Nm
M16	80 Nm

20.2 Troubleshooting

Fault	Possible cause	Corrective measures
No flow	Valve closed.	Open valve (using actuator).
	Flange covers not removed.	Remove flange covers.
Little flow	Valve not sufficiently open.	Open valve (using actuator).
	Dirt sieve clogged.	Clean / replace sieve. Relieve pressure first!
	Piping system clogged.	Check piping system.
	Kvs value of valve unsuitable.	Fit valve with higher Kvs value.
Valve spindle moves in jerks.	Stuffing box sealing too tight (for valves with graphite packings).	Slacken screw joint (25/20.17) slightly. Valve must not start leaking!
	Valve plug slightly seized owing to solid dirt particles.	Clean internals, smooth rough spots.
Valve spindle or plug cannot be moved.	Seating and plug clogged with dirt; especially with V-port and perforated plugs.	Clean seating and plug with suitable solvent.
	Valve plug seized in seating or guide owing to deposits or dirt in medium.	Replace plug and seating; use parts made from different material if necessary.
Valve spindle leaking.	PTFE V-ring unit damaged or worn.	Replace ring pack
	In valves with packed stuffing boxes, tighten sleeve nut (25).	Tighten screw joint (25); replace packing if necessary.
	Bellows defective in valves with bellow seal.	Replace bellows unit.
Leakage too high when valve is closed.	Sealing surfaces of plug eroded or worn.	Replace plug
	Sealing edge of seating damaged or worn.	Replace seating (see point 8.5), (only Fig. ...445/446)
	Piston sealing ring worn (pressure-balanced valves).	Replace sealing ring.
	Seating and/or plug dirty.	Clean internals of valve.
	Pneumatic actuator not completely vented; spring force not fully effective.	Vent actuator air chamber completely.
	Actuator not powerful enough.	Install more powerful actuator. Check service data.

21 THRUST ACTUATOR, TYPE PREMIO



Before starting up a new system or restarting a system after repairs or conversion, check:

- **Correct completion of all installation/assembly work!**
- **Circuits of the system in accordance with DIN VDE regulations and regulations of the relevant power supply company as well as compliance with all safety regulations, especially TRB 700.**
- **Hood of thrust actuator assembled.**
- **Start up only by qualified personnel**

While in operation, the thrust actuator has moving and rotating parts as well as being integrated in an electrical network system. Improper handling or failure to observe the operating instructions or the valid regulations may lead to death, grievous bodily injury or substantial property damage!

When dismantling the thrust actuator the following points are to be observed:

- **Dismantlement of the thrust actuator from the fitting must only to be carried out by suitably qualified personnel.**
- **Regard TRB 700.**
- **The supply line for connecting up the thrust actuator must be in the dead state i.e. disconnected while dismantlement work is being carried out. After being disconnected, the mains power must be prevented from being switched back on again accidentally.**
- **The system must be run down (depressurised state) as the valve cone is not held without the thrust actuator and would thus be conducted by the system pressure.**

The thrust actuators are employed to actuate control or shut-off valves requiring a nominal linear stroke distance of up to 80 mm and thrust from 2.2 kN to 15 kN. The thrust actuators are set to the thrust forces specified in the technical data.

The thrust actuator, fitted with a yoke or columns, is mounted to the valve. Transfer of force is effected via a coupling safeguarded against torsion. The torsion safeguarding feature also serves as a lift indicator. The lift settings can be read off on a lift dial attached to the yoke or between the 2-ear clamps mounted to the column.

The electrical components are accommodated separately from the gearbox underneath a sealed hood, thus being protected against operating and environmental effects. Following removal of the hood, easy access is provided to the switch gear and indicating feature. The rotary motion of the motor is transmitted to the spindle nut by means of spur gear. The drive spindle, which is safeguarded against torsion, screws its way into the spindle nut and thus performs a pull or push motion

depending on the sense of rotation. In the final positions of the valve, the spindle nut is pressed against a set of springs so as to produce closing force.

The motor is switched off by means of two load-dependent switches and one stroke-dependent switch. The load-dependent switches will also switch off the motor if foreign bodies have lodged themselves between the valve seat and cone. The load-dependent switches serve to protect the valve and thrust actuator against damage.

21.1 Manual operation

21.1.1 2.2 - 5 Kn



The handwheel always rotates during motor-driven operation (running indicator). Never activate manual operation while the motor is running. Injury hazard!

In the manual operating mode pay careful attention in the final positions that the handwheel is only turned to the point where the torque switch trips (audible click) as otherwise damage will be caused to the thrust actuator! Since the handwheel always follows during motor-driven operation (running indication), never operate by hand while the motor is running -potential injury hazards!

With the motor in the stationary state, the thrust actuator can be run in the open and closed state with the handwheel firmly meshed with the gear.

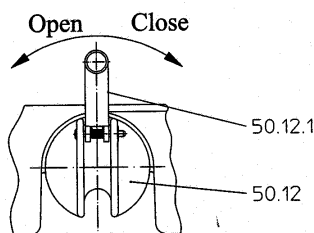

Proceed as follows:

- Swing out lever (50.12.1) from handwheel (50.12).
- Turning in clockwise direction--> closes valve.
- Turning in counter-clockwise direction--> opens valve

21.1.2 12 - 15 Kn



Do not attempt to engage manual operation until the motor has stopped. Switching over while the motor is running may damage the thrust actuator.

In the manual operating mode pay careful attention in the final positions that the handwheel is only turned to the point where the torque switch trips (audible .click) as otherwise damage will be caused to the thrust actuator!

With the motor in the stationary state, the thrust actuator can be run in the open and closed state with the engageable handwheel.

Proceed as follows:

- Fold the turning handle out of the handwheel (A)
- Turn the handwheel slightly and push in the engaging button for manual mode (8)
→ the button engages
- Turning in clockwise direction → closes valve
- Turning in counter-clockwise direction → opens valve

The motor is no longer in mesh when the handwheel is engaged. The handwheel is automatically disengaged when the motor starts and the motor is once more in mesh.

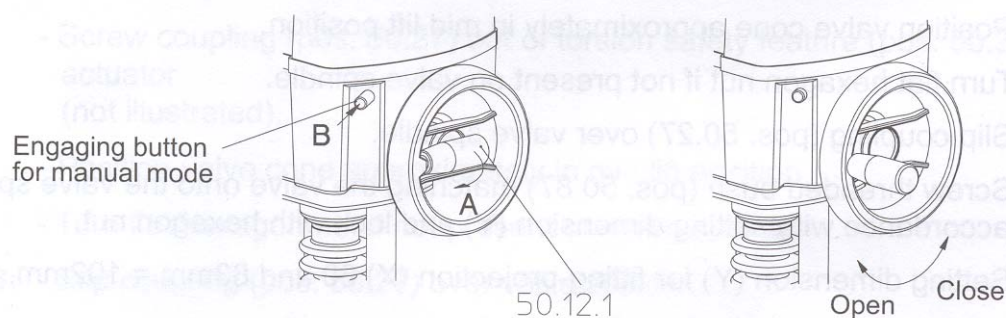

21.2 Settings



The thrust actuator may only be operated for a short time without the hood for unavoidable setting operations to the potentiometers, travel switches and the electrical options. While these operations are in progress, the thrust actuator has hazardous, live, uninsulated parts exposed as well as moving and rotating parts.

Improper execution of the setting operations or lack of care may cause death, grievous bodily injury or substantial property damage.

Operation of the thrust actuator without the hood for any purpose other than that described above is strictly prohibited.

21.2.1 Torque and travel switches -standard feature

As standard, thrust actuators are equipped with a load-dependent travel switch for the closing direction (S1), a load-dependent travel switch for the opening direction (S2) and a stroke-dependent travel switch for the opening direction (S3). The load-dependent travel switches (S1, S2) switch off the motor as soon as the factory-set thrust force is attained.



The settings of load-dependent travel switches must on no account whatsoever be changed!

The stroke-dependent travel switch (S3) switches off the motor as soon as the lift or stroke is attained. If the thrust actuator is supplied on a straight through valve, the stroke-dependent travel switch S3 is set in such a way that the motor of the thrust actuator is switched off as soon as the maximum valve-lift is attained.

If the thrust actuator is supplied on a three-way valve, the trip cam belonging to travel switch S3 is set in the opening direction in the trip slide to such a downward extent that the upper final position of the valve is attained prior to travel switch S3 being reached, thus causing the load-dependent travel switch S2 to switch off the motor.

For this function, all three switches reveal interlock-controlled circuitry on the board. If the standard travel switches are to be integrated directly into the facility control system, the standard board can be replaced by optional boards PA or NA (only 2.2- 5 kN).

21.2.2 Connection boards PA or NA (only 2.2- 5 kN)

On connection boards PA or NA, the standard travel switches S11/S21, S12/S22 and S13/S23 do not reveal interlock-controlled circuitry and can be integrated individually into the facility control system.

The 3 contacts on each of the switches S11/S21, S12/S22 and S13/S23, designed as double-throw contacts, are -in the case of these boards - brought out on terminals 40-48 and can be freely connected.

The switches on the PA optional board (standard-voltage connection board) are designed for switching capacities of up to 10A, 250V AC. The switches on the NA optional board (low-voltage connection board) are designed for switching capacities of up to 0.1 A, 4-30V (gold contacts).

21.2.3 Potentiometers

The potentiometers are used for electrical position acknowledgement on the facility control system or for the options -electronic position controller ES11 or electronic position indicator RI21

If the thrust actuator is supplied with the valve and built-in potentiometer, the potentiometer is assembled and set ready for operation.

21.3 Putting the actuator into operation



Actuator components which rotate or move during operation are coloured red. Crushing or injury hazard!

Make sure that -all works has been completed and hood of thrust actuator assembled.

When placing into service proceed as follows:

- Using the handwheel, run the thrust actuator to approximately mid lift position.
- Apply brief pulses to the thrust actuator for each direction of movement and check whether the directions of movement correspond to those desired. If this is not the case, the pulse lines governing the opening and closing action must be exchanged on the thrust actuator.

- Run thrust actuator to the final position in each direction of movement and check whether it switches off automatically and whether all externally moving parts are able to move freely.
- If failing to function properly, check all installation and setting work previously carried out, correcting if necessary, and afterwards place into service once again.

21.4 Diagram

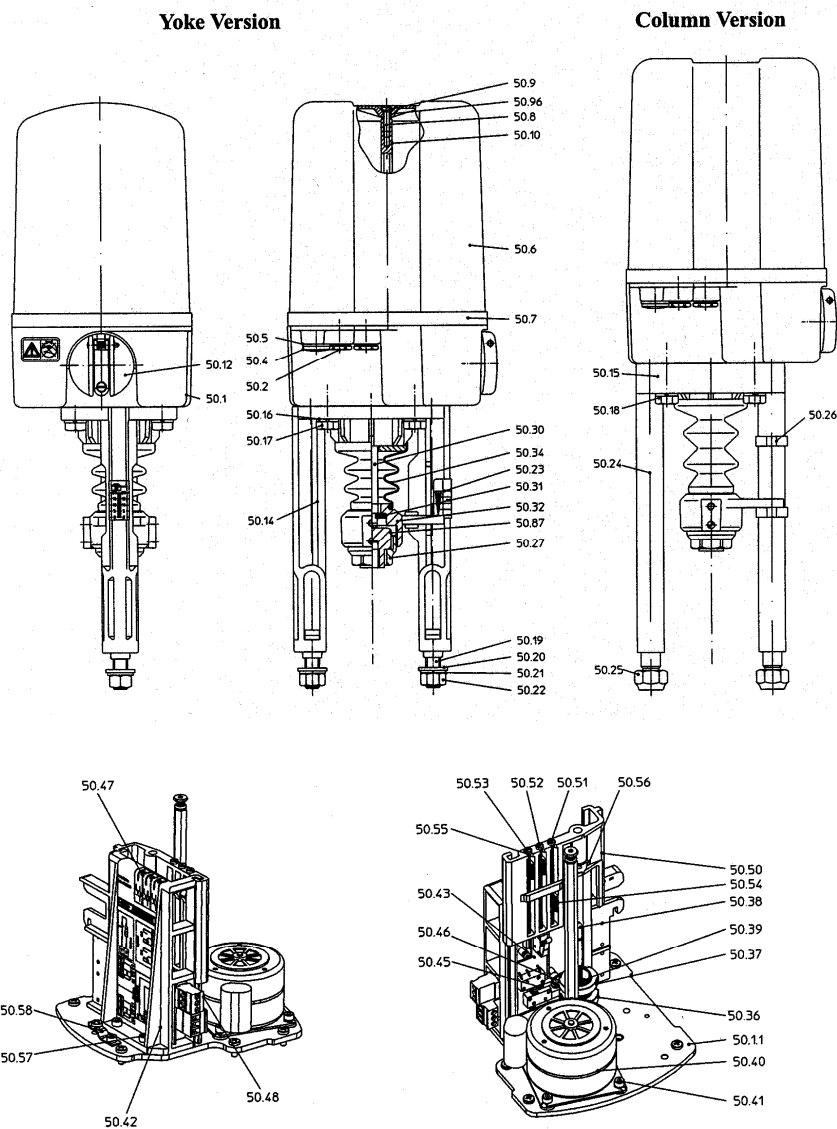

21.5 Maintenance

The thrust actuator requires very little maintenance. Accordingly maintenance in specified intervals is not necessary. Depending on the conditions governing use, the maintenance and maintenance-intervals have to be defined by the operator (see TRB 700).

The thrust actuator must not be cleaned with high-pressure equipment or aggressive solvents or detergents injurious to health or highly inflammable. During and after cleaning, an inspection should be carried out of the sealing points on the thrust actuator. If there is any sign of lubricant escaping or dirt having accumulated, the sealing elements must be repaired.

21.6 Dismantlement of thrust actuator



The supply line for connecting up the thrust actuator must be in the dead state i.e. disconnected while dismantlement work is being carried out. After being disconnected, the mains power must be prevented from being switched back on again accidentally.

The system must be run down (depressurised state) as the valve cone is not held without the thrust actuator and would thus be conducted by the system pressure.

Valve plug approximately in mid lift position -on no account supported inside a seat!

To dismantle the thrust actuator proceed as follows:

- Loosen counter-sunk screw in hood, carefully remove hood.
- Disconnect all cables led into thrust actuator from outside and remove from thrust actuator.
- Place hood on carefully from above and fix in place with counter-sunk screw and rubber gasket.
- Loosen grub screw inside torsion safety feature; screw coupling out of torsion safety feature .
- Loosen clamping bolts connecting the thrust actuator to the fitting.
- Remove thrust actuator from valve.

21.7 Troubleshooting

In the event of malfunctions or disturbances in operation, compare the data referring to operating voltage, actuating signal and temperature to the data specified on the layout drawing of the control system. Also check whether the given operating conditions correspond to those specified in the data sheet or to the technical data specified on the type identification plate.

All relevant safety regulations must be observed when carrying out the troubleshooting procedure, especially TRB 700.

Contact the supplier/manufacturer if faults cannot be rectified on the basis of the following "troubleshooting table".

21.7.1 Troubleshooting table

Fault	Possible Causes	Remedy
Thrust actuator fails to move	Power failure	Ascertain and eliminate cause
	Fuse has blown	Replace fuse
	Thrust actuator not properly connected	Rectify connection on thrust actuator in accordance with circuit diagram
	Short circuit due to: -moisture -wrong connection -motor has burned out	Ascertain exact cause, -Dry the thrust actuator and eliminate leakage -Rectify connection on thrust actuator in accordance with circuit diagram -Check whether the mains voltage agrees with the voltage specified on the rating plate. Have motor changed.
	Connector contacts not plugged in/not properly plugged into jack strip	Insert connector firmly in jack strip thus affected
	(Only for 12- 15 kN) Handwheel is still engaged and does not disengage when the motor starts up	Unscrew the motor mounting screw closest to the cable feed through. (Manual release of the handwheel disengagement mechanism.)
Thrust actuator alternates between clockwise and counter-clockwise rotation	Motor operating capacitor defective	Have motor operating capacitor replaced
Thrust actuator fails to run to final positions and also produces chatter	Load-dependent limit switches out of adjustment / defective	Remove thrust actuator and send to factory for repair
	Voltage drop due to excessively long connecting cables or inadequate conductor cross-section	Lay connecting cables in accordance with requisite output
	Mains fluctuations beyond permissible tolerance limits	Arrange for "clean" mains system within requisite tolerances
	System pressure too high	Reduce system pressure
Periodic failure on thrust actuator	Loose connection on feedline	Tighten connections on terminal strips
Thrust actuator is switched off in opening direction prior to load-dependent switch (threeway valve)	Travel switch S3 not set corresponding to use	Set travel switch S3 in accordance with operating instructions

22 VALVE, SERIES 776000

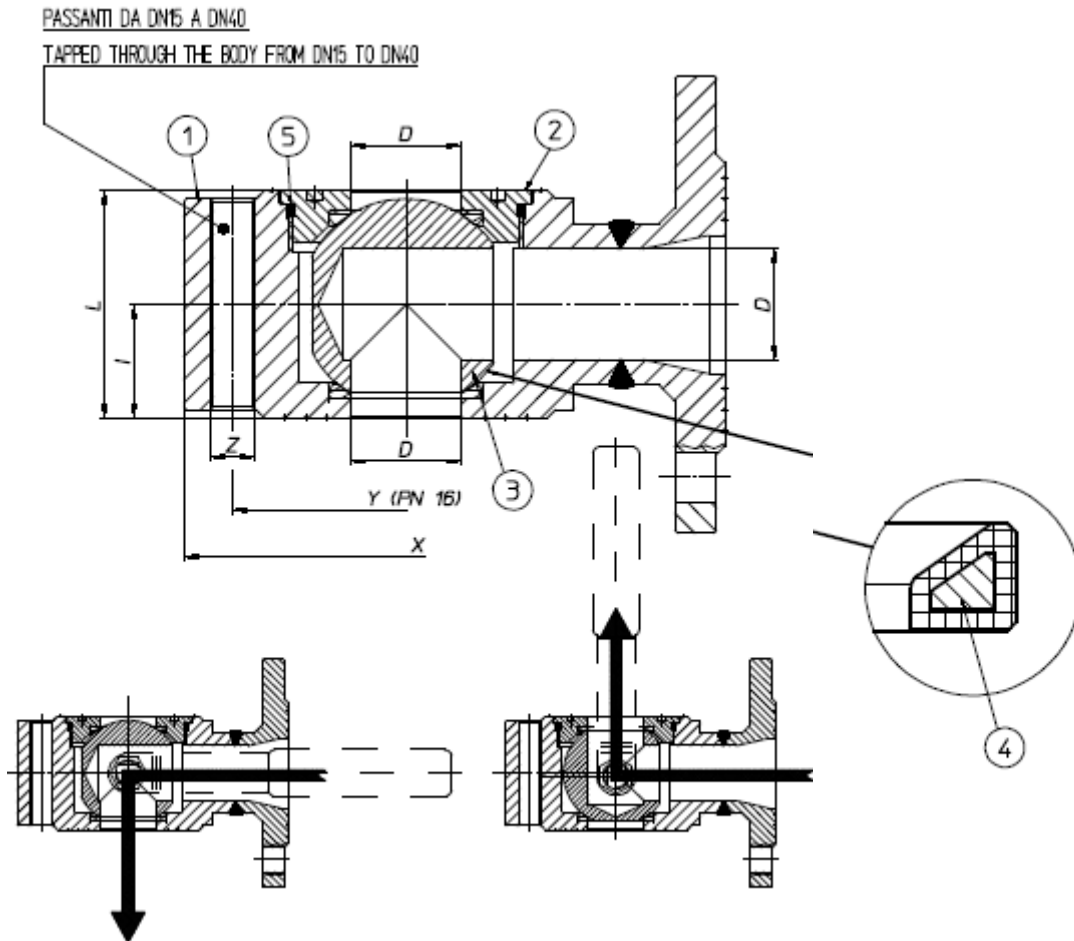

- 1 Body
- 2 End connection
- 3 Ball
- 4 Ball seats
- 5 Rings
- 6 Thrust washer
- 7 Ring
- 8 Stem seat
- 9 Packing gland
- 10 End stop
- 11 Spring washer
- 12 Nut
- 13 Stem
- 14 Handle

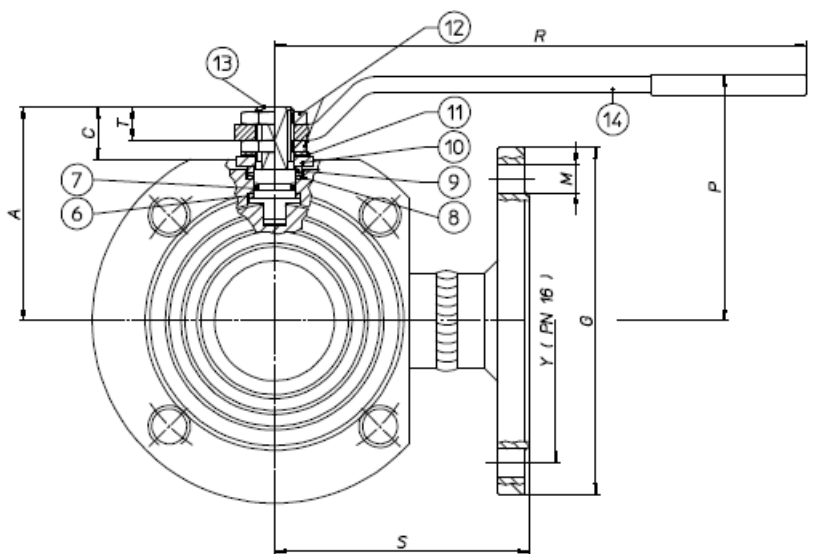

23 SWITCHBOX, SERIES W AUTOMAX

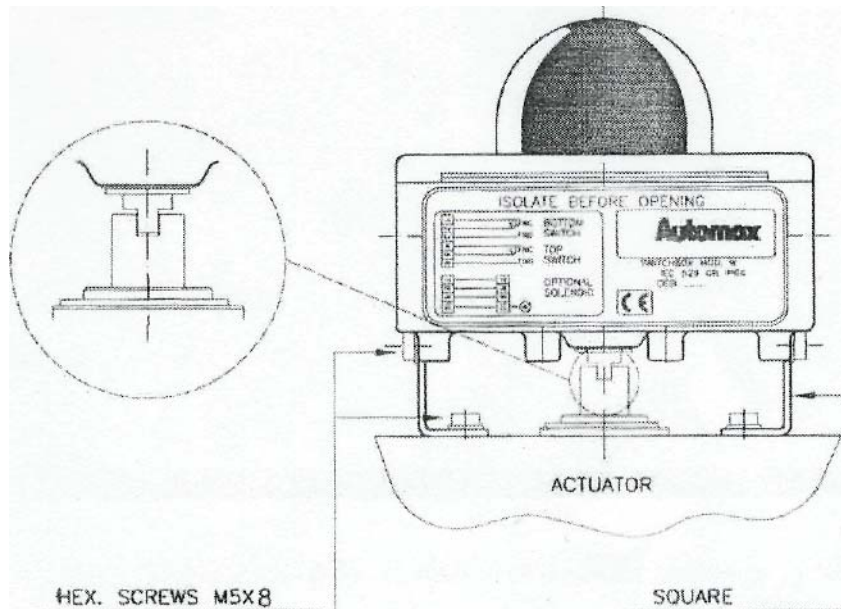

23.1 Adjusting limit switches



Disconnect power before removing the cover!

Make the actuator/valve system rotate CW, then adjust as follows:

- Pull the BOTTOM cam to disengage it from splines, then rotate it CW just until switch trips. Reengage the cam with splines.
- Make the actuator/valve system rotate CCW.
- Push the TOP cam to disengage it from splines, then rotate it CCW just until switch trips. Reengage the cam with splines.

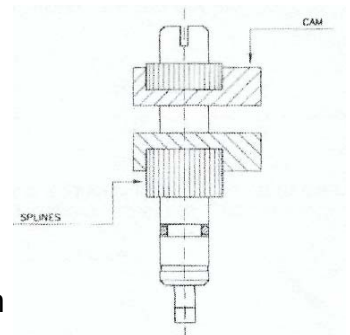

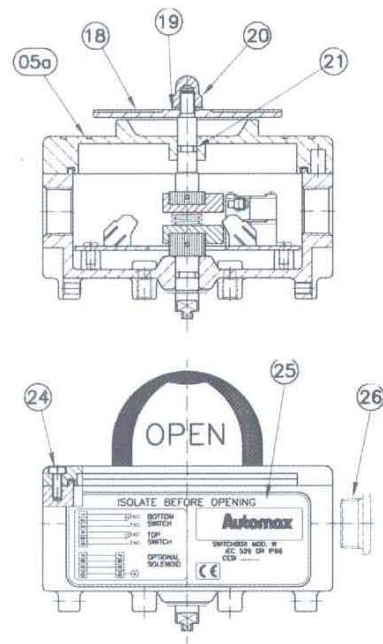
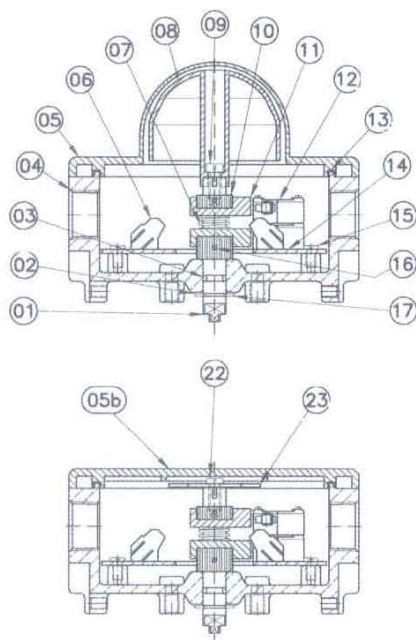

- 1 cam shaft
- 2 washer
- 3 lower shaft O-ring
- 4 body
- 5 pharos cover
- 5a metal cover
- 5b flat cover
- 6 terminal strip
- 7 cam springs
- 8 pharos rotor
- 9 pharos rotor screw
- 10 shaft retainers
- 11 cams
- 12 limit switch
- 13 cover O-ring
- 14 printed circuit board
- 15 PCB screw
- 16 elastic pins
- 17 shaft snap ring
- 18 metal position indicator
- 19 washer
- 20 blind nut
- 21 upper shft O-ring
- 22 position indicator screw
- 23 position indicator
- 24 enclosure screw
- 25 identification nameplate
- 26 plug PG 13.5

24 AUTOMATIC VENT VALVE, G8070, F8071

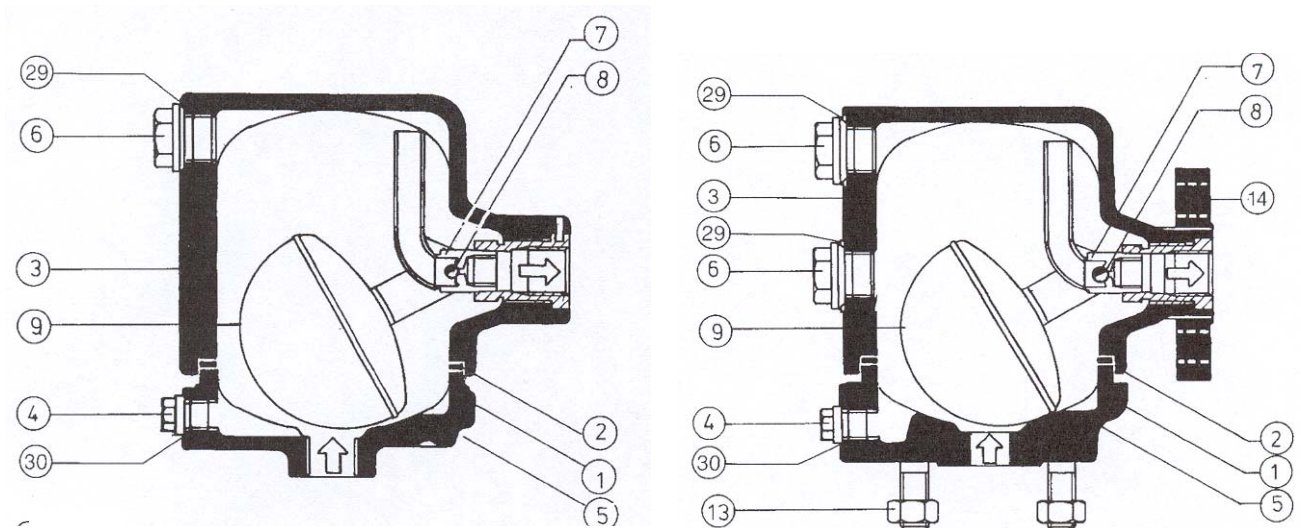

Type G

Type F

- 1 Housing cover: GG-25 or GGG-40.3
 - 2 Housing seal: soft material (asbestosfree)
 - 3 Lower part of housing: GG-251 GGG-40.3
complete with mount for control: SS 1.4104 and soft iron seal* (SS 1.4571) °
 - 4 Control screw: SS 1.4104
 - 5 Set of stud DIN 939 with nuts: DIN 934 and washer DIN 125 (not visible)
 - 6 Plug: 9S20K
 - 7 Float control complete: SS 1.4057/1.4112/1.4301/1.4541 (SS 1.4571)"
 - 8 Supporting structure with rotary-slide-valve and cotter pin*:
SS 1.4057/1.4301/1.4112/1.4541 (SS 1.4571)"
 - 9 Float with fork: SS 1.4301 (SS 1.4571)
 - 13 Set of studs: DIN 9391 with nuts DIN 934 ,
 - 14 Flange: St 37-2
 - 29 Seal: soft iron .
 - 30 Seal: soft iron
- * Individual parts cannot be delivered for reasons of tightness.

The float control assembly discharges air and gases from all liquid carrying systems without time lag, independent of pressure and temperature variations. With the float in the lower position the outlet cross-section is open. Air and gases escape through the upturned immersion tube. Rising of the liquid level lifts the float and causes to close the outlet.

25 PRESSURE RELIEF VALVE, TYPE RSB

25.1 Operation

The medium passes the valve body in the direction of the arrow. The pressure to be regulated on the upstream side is fed into the diaphragm body via a pulse line, on the actuating diaphragm. The resulting diaphragm force counteracts the spring force. If both forces are balanced the plug remains in its current position. If there is a deviation the plug moves until both forces are again in equilibrium. The desired upstream pressure is set by adjusting the hand wheel. The stem is sealed by metal bellows which also provide downstream pressure relief.

25.2 Commissioning

Figure 1 (working temperature above 100°C). Open the vent screw on the side of the actuator and pour water into the filling pipe of the water seal container until it emerges from the vent without bubbles. Now close the vent screw and continue filling until the water reaches a height of 35 mm below the top level of the filling pipe (see figure 3). After closing the filling pipe, the pressure reducing valve is ready to work. Figure 2 (working temperature less than 100°C). If the flow medium is gaseous, you can set the spill valve to work after connection. In case of liquid, the actuator must be filled completely with liquid by using its upper vent screw.



Bild 1 figure 1



Bild 1 figure 2

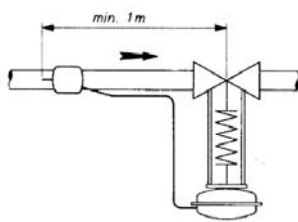

Bild 1 figure 3

25.3 Adjustment

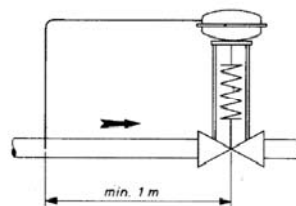
The upstream pressure can be adjusted by turning the hand wheel. For the adjustment there is a scale on each valve. The indicator is the edge of the spring-plate nearest the valve. To avoid damage of the system we suggest setting a pressure about 20 % of the full scale (lower than that wanted). For the fine adjustment a pressure gauge is to be used at a medium flow rate.

25.4 Trouble Shooting

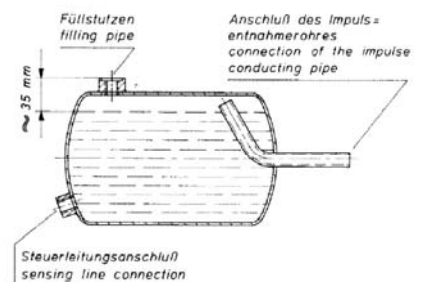
Too low pressure upstream of the valve shows, that it has lost its tightness. The reason might be damage of the spring. If this is not the case, the seat of the valve might be damaged or dirty. If the upstream pressure rises, although the adjustment is correct, the valve might be too small or the diaphragm may be damaged.

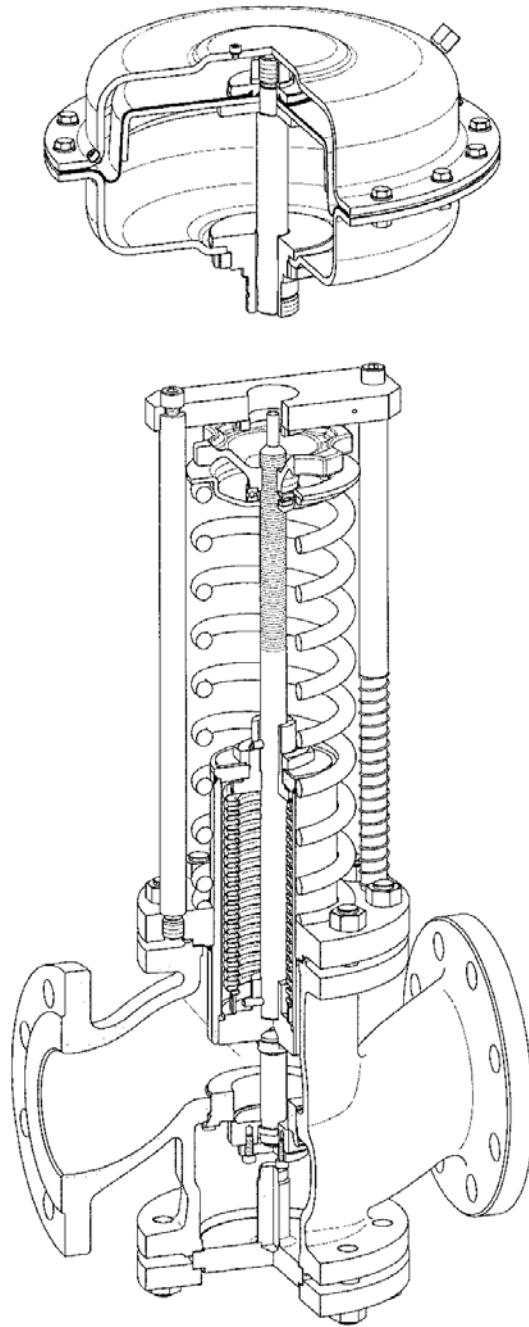
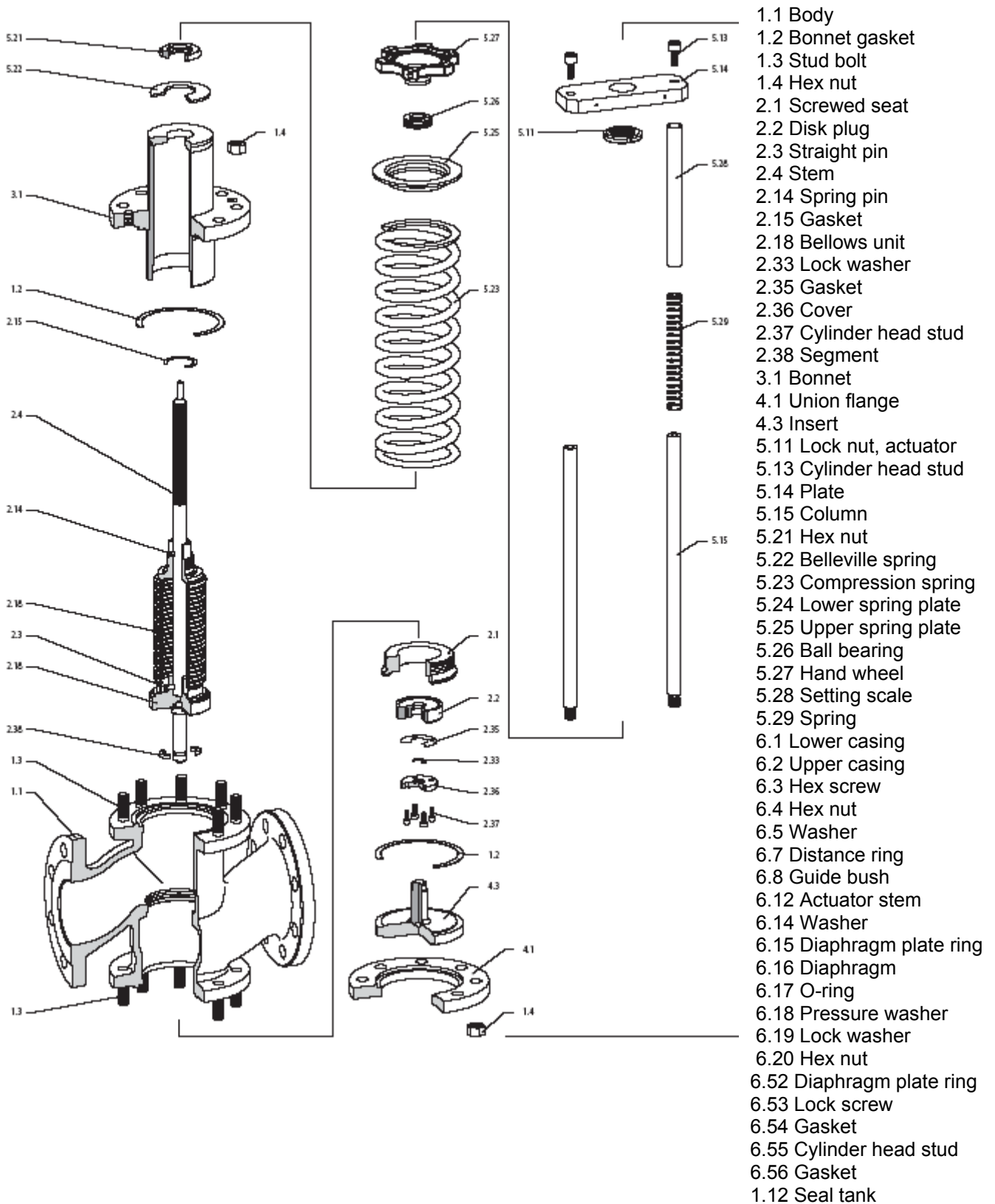

Fig 4, Type RSB-Y



26 STOP VALVE, TYPES FIG 215 AND FIG-216

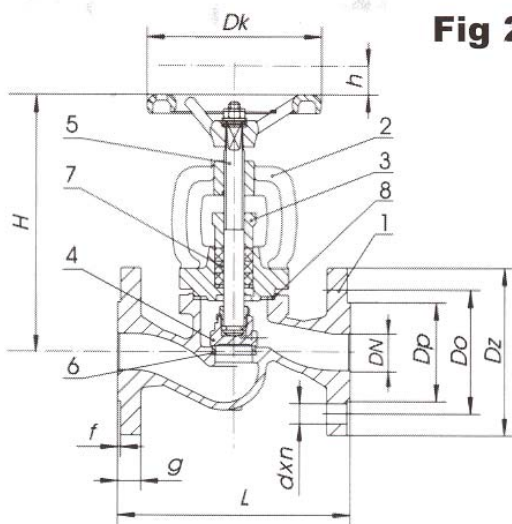

Fig 215

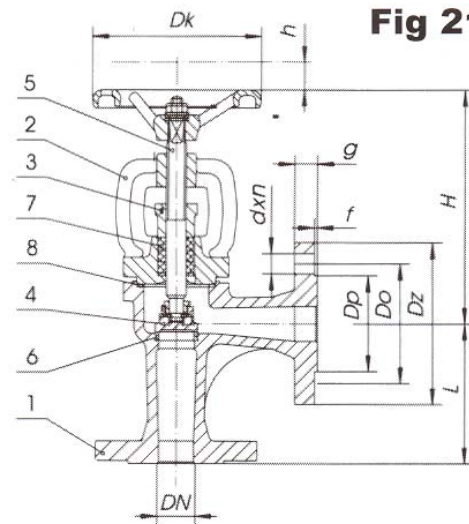

Fig 216

- 1 Body
- 2 Bonnet
- 3 Flange
- 4 Disc
- 5 Stem
- 6 Seat ring
- 7 Gland packing
- 8 Seal

These valves need no maintenance.

27 FILTER, MODEL F08

Disconnect electrical supply (when necessary) before installation, servicing, or conversion.

Disconnect air supply and depressurize all air lines connected to this product before installation, servicing, or conversion.

Operate within the manufacturer's specified pressure, temperature, and other conditions listed in these instructions.

Medium must be moisture-free if ambient temperature is below freezing.

Service according to procedures listed in these instructions.

Installation, service, and conversion of these products must be performed by knowledgeable personnel who understand how pneumatic products are to be applied.

After installation, servicing, or conversion, air and electrical supplies (when necessary) should be connected and the product tested for proper function and leakage. If audible leakage is present, or the product does not operate properly, do not put into use.

Warnings and specifications on the product should not be covered by paint, etc.

Polycarbonate bowls should not be located in areas where they could be subjected to direct sunlight, an impact blow, nor temperatures outside of the rated range. As with most plastics, some chemicals can cause damage.

Polycarbonate bowls should not be exposed to chlorinated hydrocarbons, ketones, esters and certain alcohols. They should not be used in air systems where compressors are lubricated with fire-resistant fluids such as phosphate ester and di-ester types. Metal bowls are recommended where ambient and/or media conditions are not compatible with polycarbonate bowls. Metal bowls resist the action of most such solvents, but should not be used where strong acids or bases are present or in salt laden atmospheres.

TO CLEAN POLYCARBONATE BOWLS USE MILD SOAP AND WATER ONLY! DO NOT use cleansing agents such as acetone, benzene, carbon tetrachloride, gasoline, toluene, etc., which are damaging to this plastic.

27.1 Maintenance



Maximum pressure rating is 150 psig (10.3 bar) for transparent plastic bowls, and 250 psig (17.2 bar) for metal bowls. Temperature range is 32°F to 125°F (0°C to 52°C) for transparent plastic bowls, and 32°F to 175°F (0°C to 79.4°C) for metal bowls.

27.1.1 To clean or replace bowl assembly

- a. Depressurize unit.
- b. Remove bowl and bowl guard assembly by turning counter-clockwise.
- c. Inspect bowl daily for damage or deteriorated seals. Replace with original manufacturer's approved seals and bowls.
- d. If bowl becomes dirty, replace it or clean it by wiping the bowl with a soft dry cloth or mild detergent.
- e. Before returning to service, insure that all seals have been reinstalled or replaced.
- f. Reinstall bowl and bowl guard assembly and rotate bowl guard clockwise to securely lock in place. Align arrow on bowl guard with arrow on filter body.

27.1.2 To replace filter element

- a. Depressurize unit.
- b. Remove bowl and bowl guard assembly by turning counter-clockwise.
- c. Unscrew baffle by turning counterclockwise.
- d. Remove filter element and discard.
- e. Install new filter element and reassemble in reverse order. Torque baffle to 8/10 in./lbs (0.90/1.1 N-m).
- f. Before returning to service, insure that all seals have been reinstalled or replaced.
- g. Reinstall bowl and bowl guard assembly and rotate bowl guard clockwise to securely lock in place. Align arrow on bowl guard with arrow on filter body.

Filter element should be replaced when pressure drop across the unit exceeds 10 psi differential pressure.

DRAIN BOWL DAILY to remove liquid, water, oil and solid particulates that have accumulated in the bowl reservoir. To do so, rotate the drain knob to the left one or two turns.

NOTE: In the event the drain knob is over-rotated, it may become disengaged from the drain stem. In such a case, pull down on both the knob and the stem while rotating to the right to re-engage.

28 SINGLE FILTER 1.03.2

The filter casing is designed to meet the current regulations for the range of pressures in question. The filter elements are resistant to differential pressure. The admissible values are shown on the nameplate of the differential pressure indicator. The effective differential pressures which are economically advisable are 0.8 bar for filters with filter mesh and 2 bar for filters with micro-cartridges.



According to the AD Information Sheets, the filter housings are only rated for internal overpressure. Additional external forces and moments at the connection flanges of the filter are to be avoided (possibly support feed lines).

28.1 Commissioning

28.1.1 Pressure filters (>01.1 bar pressure in the filter)

1. Open the air vent of the filter chamber (only about 1 turn of venting screw)
2. Start the plant up slowly
3. Close air vent when the air has escaped and liquid starts to emerge. The filter is now ready for operation.

Cleaning

The filter element has to be cleaned or the cartridge changed at a differential pressure of 0.8 bar in filters with filter mesh and 2 bar in filters with a micro-cartridge.

1. Open the air vent of the isolated filter; this relieves the liquid pressure.
2. Dismantle the casing cover of the isolated filter.
3. Open the drain.
4. Drain the liquid down to the strainer base in the case of basket strainers; drain filter casing completely in the case of jacket strainers, cartridge strainers and micro-cartridges.
5. Remove the filter element vertically upwards.
6. Clean filter element (see operating instructions "Strainer cleaning"); replace disposable elements with new ones and install them in the filter.
7. When mounting the cover, check that the seal is in perfect condition and seated properly; if necessary, replace seal. Screw cover on, the air vent remains open.
8. Close drain.
9. Slowly start up plant. Open the inlet shut-off valve slightly.
10. Close air vent as soon as the air has escaped and liquid emerges.
11. Open both shut-off valves fully.

28.1.2 Suction filters (< 0.1 bar pressure in the filter)

1. Fill and vent the filter chamber.
2. Start up plant.
3. When the differential pressure across the filter inlet and outlet reaches the maximum allowed by the pump suction head, the filter element must be cleaned or the cartridge replaced.

Cleaning

1. Stop plant and close shut-off valves upstream and downstream of the filter.
2. Open air vent of the isolated filter.



Air may be sucked in if the liquid level drops

3. Dismantle casing cover from the isolated filter.
4. Open drain.
5. Drain liquid.
6. Remove filter element vertically upwards.
7. Clean filter element (see operating instructions "Strainer cleaning"). Replace disposable elements with new ones and install them in the filter.
8. Fill filter casing.
9. When mounting the cover, check that the seal is in perfect condition and seated properly; if necessary, replace seal, and close air vent.
10. Open both shut-off valves.



It is not permitted to fill the filter against the indicated flow direction of the filter elements.

28.2 Maintenance

The single filter is maintenance-free.

28.2.1 Cleaning the multi-mantle filter elements

The multi-mantle filters consist of up to 6 nested filter elements. Fields of application are filter meshes < 200 µm. In order to prevent flow short-circuits, the joins of the individual components are sealed with O-rings. The admissible differential pressures depend on the multi-mantle filter diameter:

Filter Ø (mm)	Δp max. oper. (bar)
86-230	1,2
290	0,8
356-434	0,8

Clean and inspect multi-mantle filter elements at regular intervals. The length of these intervals depends on the amount of dirt that has accumulated.

Carry out the first cleaning operation immediately after the installation has been flushed. A rising pressure loss is a sign of increasing dirt accumulation.

The differential pressure is not to exceed 0.8 or 1.2 bar.

Before opening the filter chambers, observe the operating instructions for single and duplex filters.

Cleaning

1. Shut off single filter or change over duplex filter. Release pressure from the filter housing by undoing the venting screw and remove the housing cover. Open the drain screw in the filter base and drain contents completely. Slacken the self-locking nut (4) on the central tie rod (5) and lift out the inner filter with the lifting eye (18). Lift the remaining filter elements out individually by gripping the inside of the filter ring.
2. Place the individual filter elements into containers with cleaning agent and brush off with not too hard a brush (e.g. nylon brush).
3. Now blow compressed air at about 4 bar through the filter element cleaned in the above manner from the clean side. To this end insert the cleaning gun type 5.02 (22) into the openings located in the upper filter ring and blow through the filter surface from the inside with up and down motions.
4. In the case of persistent dirt or paint encrustation, place the filter into a with cleaning agent (to sheet KV 349) and allow to soak for up to 4 hours. Make sure that the filter is not completely immersed but that the upper ring remains free. This prevents dirt from reaching the clean side.
5. Remove filter and continue to treat as described under points 2 and 3.
6. If necessary, repeat points 4 and 5.

7. For final cleaning, rinse the filter in clean cleaning fluid (e.g. petroleum ether, paraffin, hot water or similar) and blow through again. Then check fabric for cleanness and damage. Assess cleaning effect by holding the filter element against the light. Use a torch for finer fabrics. If the light penetrates evenly, the fabric has been cleaned well.
8. Check all seals including cover seals. Seals which have become hard and deformed must be renewed without fail.

Cleaning appliances

- 2 cleaning containers.
- Cleaning gun, type 5.02.
- 10 mm spanner.
- Compressed air connection, max. 6 bar.
- For particularly convenient and thorough filter cleaning a cleaning trolley type 5.04 with cartridge filter, pump and cleaning gun is recommended. Please contact Auramarine Ltd.

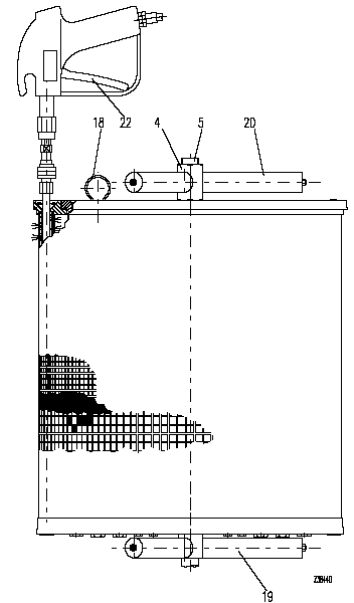

28.3 Cover securing device for double filters

The function of the cover securing device is to prevent the uncontrolled escape of lubricantes and fuels in the case of operating errors. The cover plate (2) covers a minimum number of cover screws (3), so that the cover (1) cannot be removed with out actuating the venting facility (4).

The filter chamber is relieved through the venting screw (4). With the correct switching position, the service pressure of the filter chamber falls immediately and hardly any fuel escapes. Otherwise, the venting screw is immediately closed and the fuel discharge is limited.

28.3.1 Operating

1. Establish on the circuit diagram (5) with chamber is switched off.
2. Unscrew the venting screw of this chamber (4) to the point where the cover plate (2) can swivel over the cover screws (3)
3. Loosen cover screws (3) and remove cover (1)
4. Assemble in reverse order

Check seals items 6 and 7 for damage.

5. For sieve cleaning and commissioning, see Sieve Cleaning Operating Instructions and Double Filter Operating Instructions.

TYP 2.93.2 DN25

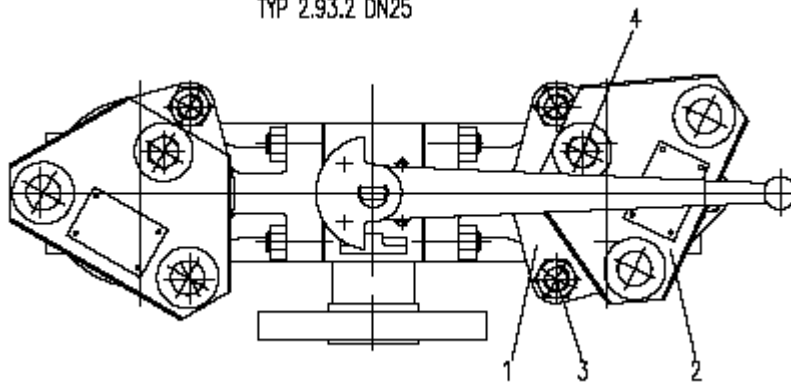

TYP 2.93.2 / 2.62.9 DN50-80

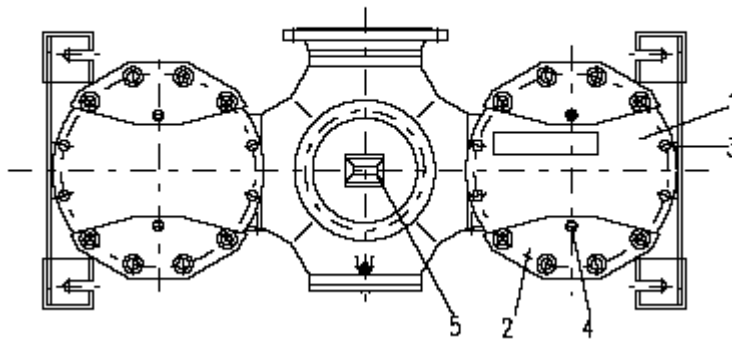

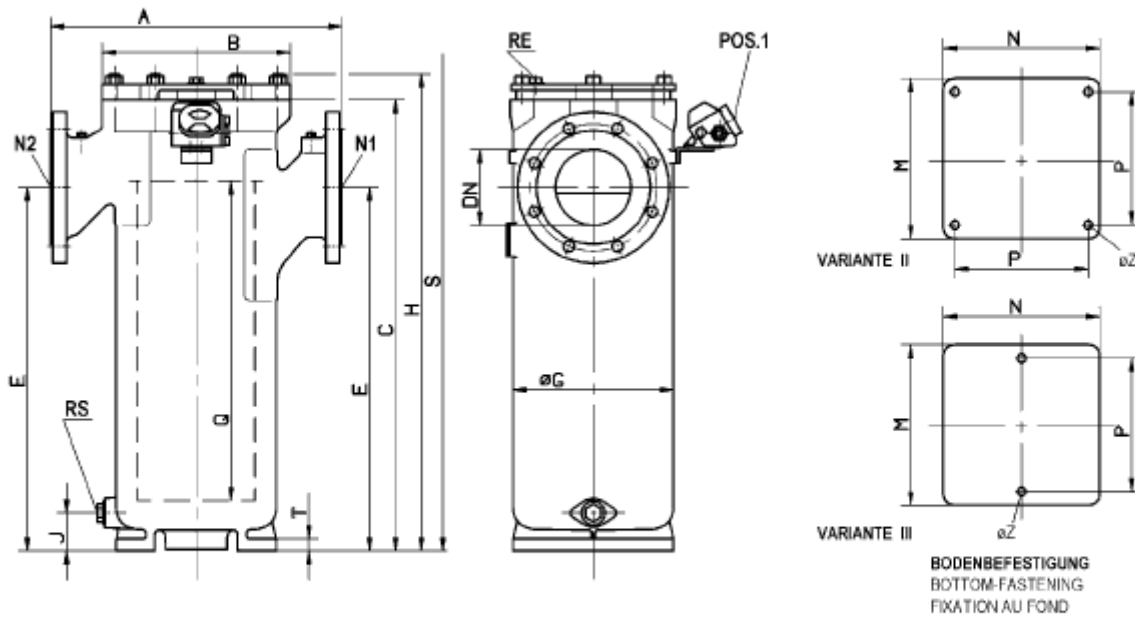

N1 FILTEREINTRITT
FILTERINLET
ENTRÉE DE FILTRE

N2 FILTERAUSTRITT
FILTEROUTLET
SORTIE DU FILTRE

BEI KORB- ODER RINGSIEBEN DURCHFLUSS UND DDA-ANBAU ENTGEGENGESETZT
WITH BASKET- OR RINGELEMENTS AND DPI MOUNTED OPOSITE FLOW DIRECTION REFERS
AVEC DES PANIERS À CORBEILLE OU À ANNE AUX, L'INDICATEUR DE LA PRESSION DIFFERENTIELLE ETANT AU COTÉ OPPOSÉ, LE SENS DU PASSAGE DE DU FLUIDE EST CONTRAIRE

RE ENTLÜFTUNG
AIR ESCAPE
DÉSÀÉRATION

RS ENTLERUNG
DRAIN
VIDANGE

S SIEBAUSBAU
DISMOUNTING OF THE FILTER ELEMENT
DÉMONTAGE DU PANIER

GEHÄUSE GEGOSSEN
CASTED HOUSING
CORPS MOULÉ

ALLGEMEINTOLERANZEN DIN ISO 2768-V
TOLERANCE DIN ISO 2768-V
TOLÉRANCE DIN ISO 2768-V

N1/N2 NACH DIN2501 PN10 GEBOHRT
N1/N2 DRILLED ACC. TO DIN2501 PN10
N1/N2 PERCÉE D'APRÈS DIN2501 PN10

AUF WUNSCH , ON REQUEST , SUR DEMANDE
POS.1 DIFFERENZDRUCKANZEIGER
DIFFERENCE PRESSURE INDICATOR
INDICATEUR DE DIFFÉRENCE DE PRESSION

BESTELLBEISPIEL TYP øG Q DN PN
ORDERING EXAMPLE 1.03.2 195 500 80 10
EXEMPLE DE COMMANDE

øG	Q	DN N1/N2	PN 200°C	A	B	C	E	H	S	J	RE	RS	BL.	M	N	P	T	Z	VOL. L	GEW. KG
96	125	20	10	184	□ 102	190	155	235	385	25	G1/4	G1/4							1	7
110	200	25	10	200	□ 120	299	246	340	585	26	G1/4	G1/2							2	12
128	175	32	10	220	□ 140	280	224	320	580	30	G1/4	G1/2							3	15
154	205	40	10	270	□ 167	333	270	375	590	50	G1/4	G1/2	II	140	100	120	25	M12x24	5	28
	300	50		280	□ 168	450	365	490	800	55									7	36
186	250	65	10	320	□ 200	415	310	460	800	50	G1/4	G1	II	195	196	190	17	ø14	9	40
	500	80		330		685	585	740	1280	55									16	51
265	500	100	10	480	ø310	745	600	790	1360	62	G1/2	G1	II	265	265	220	20	ø14	34	98
		125																		
340	500	150	10	520	ø340	772	600	815	1440	70	G1/2	G1	II	340	330	290	20	ø18	66	140
420	500	200	10	700	ø420	850	555	905	1550	80	G1/2	G1	II	420	420	380	25	ø18	98	285
520	500	250	10	710	ø450	910	660	950	1700	85	G1/2	G1/2	II	520	520	480	25	ø23	157	350
	750	300		800	1185	865	1225	2235	95	212									465	

SUBJECT TO ALTERATIONS

ÄNDERUNGEN VORBEHALTEN!

MODIFICATIONS RÉSERVÉES

SINGLE FILTER

EINFACHFILTER 1.03.2

FILTRE SIMPLE

Z45550
TYP4.36.2
09.01.06

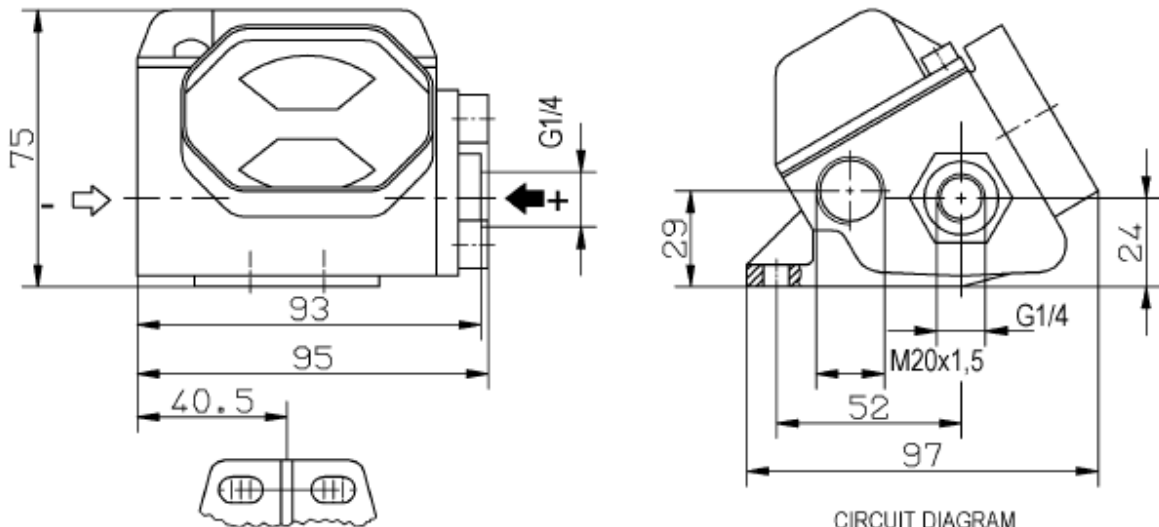

CIRCUIT DIAGRAM

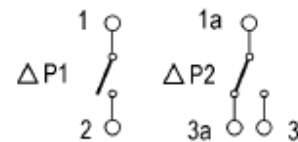

SPECIFICATION:
PROTECTION CLASS: IP 65

ELECTR. DATA:	SWITCHING VOLTAGE	V [∞] MAX.=	250	220
	FREQUENCY	HZ MAX.=	0-60	0-60
	SWITCHING CURRENT	A MAX.=	1	0.8
	MAKING AND/OR BREAKING CAPACITY	WVA MAX.=	60/60	40/60

MATERIAL : GD - ALUMINIUM
RATING : MAX. PRESSURE 100 BAR
MAX. TEMPERATURE 150°C

RANGES OF PRESSURE DIFFERENTIAL: DELTA P =

0 - 0.5 BAR] TO BE SPECIFIED WHEN ORDERING
0 - 0.8 BAR	
0 - 1.2 BAR	
0 - 2.0 BAR	
0 - 3.0 BAR	

DESCRIPTION:

THE PURPOSE OF THIS DEVICE IS THE MEASUREMENT, AND VISUAL INDICATION OF THE DIFFERENCE IN PRESSURE BETWEEN TWO POINTS, AND THE ESTABLISHMENT OF AN ELECTRICAL CONTACT WHEN THE PRESSURE DIFFERENTIAL ATTAINS A SPECIFIED FIGURE.

METHOD OF OPERATION:

A PLUNGER SEALED BY A DIAPHRAGM SEPARATES THE SPACE UNDER PRESSURE INTO TWO CHAMBERS. A PRE-LOADED SPRING CAUSES THE PLUNGER TO TAKE UP ITS ZERO POSITION WHEN THE PRESSURE DIFFERENCE DELTA P IS ZERO. AS THE PRESSURE DIFFERENCE INCREASES (DELTA P > 0), THE PLUNGER IS FORCED TO MOVE AGAINST THE SPRING. AT THE SAME TIME, AN INDICATOR DISC IS MOVED MAGNETICALLY, AND THEREFORE VIRTUALLY WITHOUT FRICTION, AND THE TWO REED CONTACTS ARE ACTUATED.

THE RED SEGMENT OF THE INDICATOR DISC IS VISIBLE OVER A PRESSURE RANGE EQUAL TO APROX.50-100% DELTA P . THE FIRST REED CONTACT IS ACTUATED AT 75% DELTA P1, AND THE SECOND AT 100% DELTA P2.

DIFFERENTIAL PRESSURE CONTACT INDICATOR TYPE 4.36.2

Z21434
TYP4.36.2+4.46.2
11.02.94

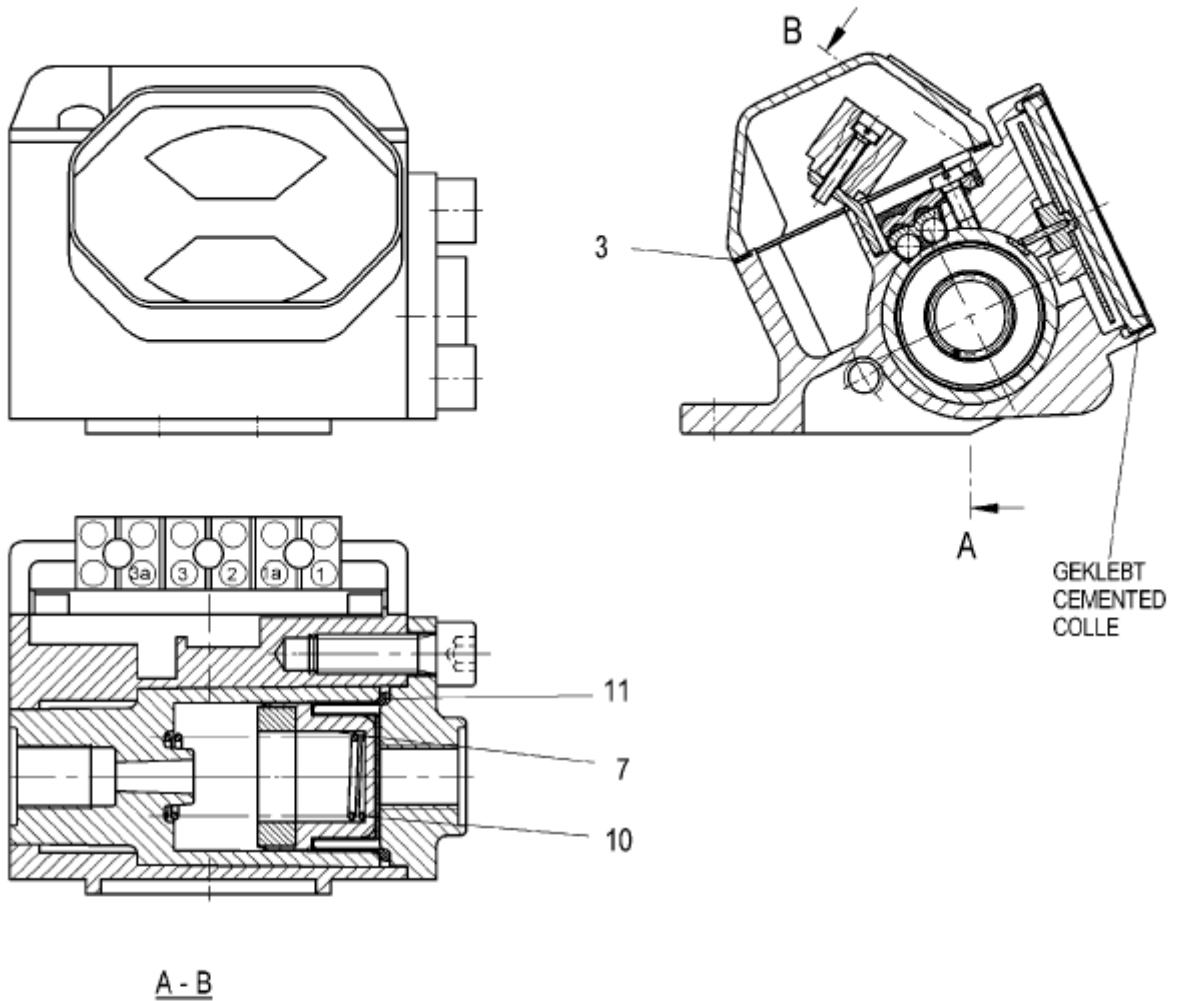

BEI BESTELLUNG ANGEBEN
TO BE MENTIONED IN CASE OF ORDER
A MENTIONNER LORS DE LA COMMANDE

AUFTR.NR.:
ORDER NO.
NO DE COMMANDE

TYP 4.36.2

11	ROLLMEMBRAN	DIAPHRAGM	DIAPHRAGME	
10	FEDER	SPRING	RESSORT	
7	KOLBEN	PISTON	PISTON	
3	DICHTUNG	GASKET	JOINT	
POS.NR.	BEZEICHNUNG	DESIGNATION	DESIGNATION	

SPARE PARTS
DRAWING

ERSATZTEILZEICHNUNG
ZUM TYP 4.36.2 UND 4.46.2

PLAN DES PIECES
DE RECHANGE

Z13866/1A
27.04.2000

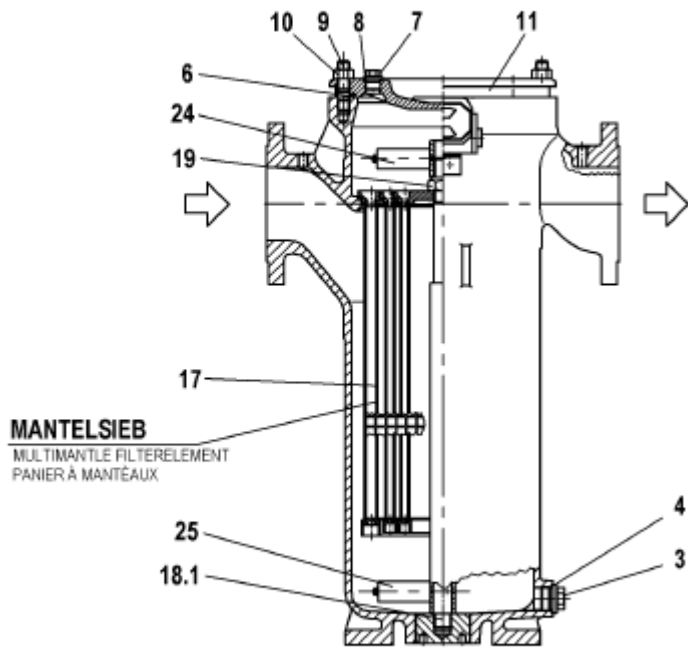

TYP 1.03.2

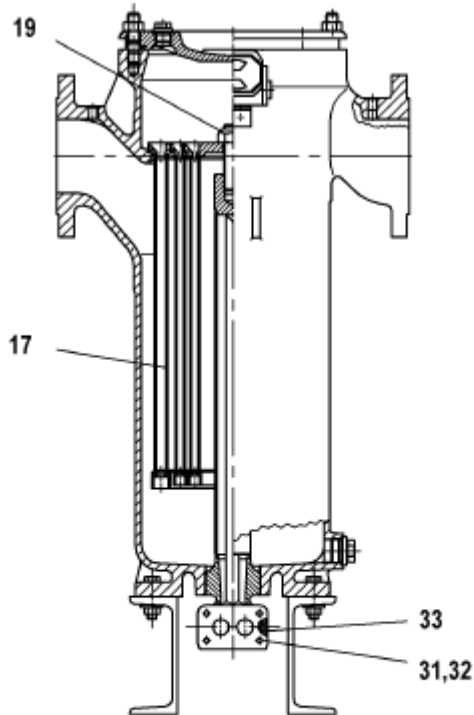

TYP 1.03.2.4

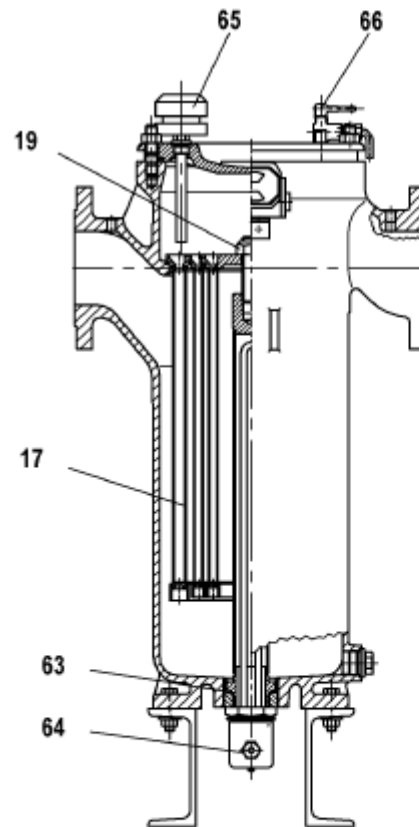

TYP 1.03.2.5

SPARE PART LIST

ERSATZTEILLISTE TYP 1.03.2 / 1.03.2.4 / 1.03.2.5

LIST DES PIÈCES
DE RECHANGE

28.4 Spare parts

1.03.2 =	Einfachfilter aus GG25 (GGG40)	single filter made of GG25 (GGG40)	Filtere simple en GG25 (GGG40)
G =	Gehäusedurchmesser	cabin diameter	diamètre du corps
Q =	Filtereinsatzlänge	length of the filter element	longueur du panier
DN =	Anschlußflansche	connection flanges	brides désirées

Pos. Nr.	Bezeichnung Designation Designation	Gr. 96/125 DN 20	St.	Gr. 110/200 DN 25	St.	Gr. 126/175 DN 32	St.	Gr. 154/205 DN 40	St.	Gr. 154/300 DN 50	St.	Gr. 195/250 DN 65	St.	Gr. 195/500 DN 80	St.
3	Verschlußschraube screw plug vis	2002885	1	2000189	1	2000189	1	2000189	1	2000189	1	2000189	1	2000191	1
4	Dichtung gasket joint	3270002	1	3270004	1	3270004	1	3270004	1	3270004	1	3270004	1	3270006	1
6	Dichtung (Perbunan) gasket joint (Asbestfrei)	3340053 3380001	1	3340054 3380002	1	3340055 3380004	1	3340056 3380006	1	3340056 3380006	1	3340057 3380008	1	3340057 3380008	1
7	Verschlußschraube screw plug bouchon	2002885	1	2002885	1	2002885	1	2002885	1	2002885	1	2002885	1	2002885	1
8	Dichtung gasket joint	3270002	1	3270002	1	3270002	1	3270002	1	3270002	1	3270002	1	3270002	1
9	Stiftschraube Stud bolt vis	2000002	4	2000004	4	2000004	4	2000007	4	2000007	4	2009088	4	2009088	4
10	Mutter nut écrou	2100005	4	2100006	4	2100006	4	2100007	4	2100007	4	2100007	4	2100007	4
11	Deckel cover couvercle	4-570	1	4-759	1	4-758	1	4-854	1	4-854	1	3-18988	1	3-18988	1

Pos. Nr.	Bezeichnung Designation Designation	Gr. 96/125 DN 20	St.	Gr. 110/200 DN 25	St.	Gr. 126/175 DN 32	St.	Gr. 154/205 DN 40	St.	Gr. 154/300 DN 50	St.	Gr. 195/250 DN 65	St.	Gr. 195/500 DN 80	St.
11 a	Deckel cover couvercle	4-577	1	4-1839	1	4-739	1	4-4882	1	4-4882	1	4-4883 (SV)	1	4-4883 (SV)	1
12	Bügel Strap étrier	WN 68.2	1	4-24397	1	3-24399	1	3-24401	1	3-24401	1	3-24414	1	3-24414	1
13	Druckbolzen plug boulo	5900111	1	5900112	1	5900112	1	5900112	1	5900112	1	5900113	1	5900113	1
14	Bügelschraube bolt vis	DIN 601 M 10 X 75	2	2000027	2	2000041	2	WN 69.3	2	WN 69.3	2	WN 69.3	2	WN 69.3	2
15	Haltescheibe plate dique	WN 66.1	1	WN 66.2	1	WN 66.2	1	WN 66.2	1	WN 66.2	1	WN 66.3	1	WN 66.3	1
16	Zylinderschraube Chesse Hd. Sc. Six pans Cr.	2000109	2	2000120	3	2000120	3	2000120	3	2000120	3	2000120	3	2000120	3
17	Siebeinsatz filter element élément filtre	Fabr.Nr. Filtertyp		Fabr.No. Filtertype		Fabr.No. Type de Filtre		Fabr.Nr. Filtertyp		Fabr.No. Filtertype		Fabr.No. Type de Filtre		Fabr.Nr. Filtertyp	
18.1	Anker bolt vis	WN 5.1.70	1	WN 5.1.80	1	WN 5.1.72	1	WN 5.1.80	1	4-7081	1	WN 5.1.81	1	WN 5.1.83	1
18.2	Anker bolt vis	-----		-----		-----		-----		-----		WN 5.1.82	1	WN 5.1.84	1
19	Mutter nut écrou	2100032	1	2100033	1	2100032	1	2100033	1	2100033	1	2100033	1	2100033	1
20	Zinkschutz zinc protector plaque de protection zinquée	WN 160 Nr.1	1	WN 160 Nr.1	1	WN 160 Nr.1	1	WN 160 Nr.1	1	WN 160 Nr.1	1	WN 160 Nr. 1	1	WN 160 Nr.1	1
21	Senkschraube bolt vis	2009609	2	2009609	2	2009609	2	2009609	2	2009609	2	2009609	2	2009609	2

Pos. Nr.	Bezeichnung Designation Designation	Gr. 96/125 DN 20	St.	Gr. 110/200 DN 25	St.	Gr. 126/175 DN 32	St.	Gr. 154/205 DN 40	St.	Gr. 154/300 DN 50	St.	Gr. 195/250 DN 65	St.	Gr. 195/500 DN 80	St.
24	Magnetnachfilter magnet sec.-filter filtre magn. final	-----		-----		-----		1711932	1	1711932	1	1718195	1	1718195	1
25	Magnetvorfilter magnet prim.-filter filtre magn. prim	-----		-----		-----		-----		1715658	1	1718395	1	1718395	1
31	Sechskantschraube spanner bolt écrou hexagon	-----		-----		-----		-----		2000001	4	2000001	4	2000001	4
32	Sechskantmutter nut écrou	-----		-----		-----		-----		2100004	4	2100004	4	2100004	4
33	Flachdichtung gasket joint	-----		-----		-----		-----		18109		18109		18109	
63	O-Ring (Viton) O-Ring (Perbunan) O-Ring (Perbunan)	-----		-----		-----		-----		3030172 3040158		3030172 3040158	1	3030172 3040158	1
64	ElektrischeHeizung electrical heating chauffage electr.	-----		-----		-----		-----		09225/02	1	09225/02	1	09225/05	1
65	Thermostat thermostat thermostat	-----		-----		-----		-----		4600001	1	4600001	1	4600001	1
66	Entlüftung air escape désaération	-----		-----		-----		-----		11093 WN 103-1	1	11093 WN 103-1	1	11093 WN 103-1	1

1.03.2 = Einfachfilter aus GG25 (GGG40)
G = Gehäusedurchmesser
Q = Filtereinsetzlänge
DN = Anschlußflansche

single filter made of GG25 (GGG40)
cabin diameter
length of the filter element
connection flanges

Filtre simple en GG25 (GGG40)
diamètre du corps
longueur du panier
brides désirées

Pos. Nr.	Bezeichnung Designation Designation	Gr. 265/500 DN 100	St.	Gr. 265/500 DN 125	St.	Gr. 340/500 DN 150	St.	Gr. 420/500 DN 200	St.	Gr. 520/500 DN 250	St.	Gr. 520/750 DN 300	St.
3	Verschlußschraube screw plug vis	2000191	1	2000191	1	2000191	1	2000191	1	2000193	1	2000193	1
4	Dichtung gasket joint	3270006	1	3270006	1	3270006	1	3270006	1	3211328	1	3211328	1
6	O-Ring (Viton) O-Ring (Perbunan) O-Ring (Perbunan)	3030183 3040131	1	3030183 3040131	1	3030184 3040135	1	3034406 3040151	1	3031074 3040155	1	3031074 3040155	1
7	Verschlußschraube screw plug bouchon	2000189	1	2000189	1	2000189	1	2000189	1	2000189	1	2000189	1
8	Dichtung gasket joint	3270003	1	3270003	1	3270003	1	3270003	1	3270003	1	3270003	1
9	Stiftschraube Stud bolt vis	2009088	6	2009088	6	2000011	6	2000011	8	2000102	12	2000102	12
10	Mutter nut écrou	2100007	6	2100007	6	2100008	6	2100008	8	2100009	12	2100009	12
11	Deckel cover couvercle	4-18118	1	4-18118	1	3-17648	1	3-19067	1	3-19508	1	3-19508	1

Pos. Nr.	Bezeichnung Designation Designation	Gr. 265/500 DN 100	St.	Gr. 265/500 DN 125	St.	Gr. 340/500 DN 150	St.	Gr. 420/500 DN 200	St.	Gr. 520/500 DN 250	St.	Gr. 520/750 DN 300	St.
11 a	Deckel cover couvercle	4-17007 (SV)	1	4-17007 (SV)	1	4-20754 (SV)	1	4-29861 (SV)	1	-----		-----	
12	Bügel Strap étrier	3-24416	1	3-24416	1	4-20589	1	3-29862	1	-----		-----	
13	Druckbolzen plug boulo	5900113	1	5900113	1	5900113	1	5900114	1	-----		-----	
14	Bügelschraube bolt vis	WN 69.3 M 16 x 95	2	WN 69.3 M 16 x 95	2	2000061	1	DIN931/3-29862 M20x100/ Nacharb. Pos.4	1	-----		-----	
15	Haltescheibe plate dique	WN 66.3	1	WN 66.3	1	WN 66.3	1	WN 66.3	1	-----		-----	
16	Zylinderschraube Chesse Hd. Sc. Six pans Cr.	2000120	3	2000120	3	2000120	3	2000120	3	-----		-----	
17	Siebeinsatz filter element élément filtre	Fabr.Nr. Filtertyp		Fabr.No. Filtertype		Fabr.No. Type de Filtre		Fabr.Nr. Filtertyp		Fabr.No. Filtertype		Fabr.No. Type de Filtre	
18.1	Anker bolt vis	WN 5.1.91	1	WN 5.1.91	1	WN 5.1.91	1	WN 5.1.91	1	WN 5.1.91	1	WN 5.1.94	
18.2	Anker bolt vis	WN 5.1.92	1	WN 5.1.92	1	WN 5.1.92	1	WN 5.1.92	1	WN 5.1.92	1	WN 5.1.95	1
19	Mutter nut écrou	2100035	1	2100035	1	2100035	1	2100035	1	2100035	1	2100035	1

Pos. Nr.	Bezeichnung Designation Designation	Gr. 265/500 DN 100	St.	Gr. 265/500 DN 125	St.	Gr. 340/500 DN 150	St.	Gr. 420/500 DN 200	St.	Gr. 520/500 DN 250	St.	Gr. 520/750 DN 300	St.
20	Zinkschutz zinc protector plaque de protection zinquée	WN 160 Nr.1	1	WN 160 Nr.1	1	WN 160 Nr.1	1	WN 160 Nr.1	1	-----		-----	
21	Senkschraube bolt vis	2009609	2	2009609	2	2009609	2	2009609	2	-----		-----	
24	Magnetnachfilter magnet sec.-filter filtre magn. final	1717701	1	1717701	1	1717701	1	1716144	1	1716144	1	1716144	1
25	Magnetvorfilter magnet prim.-filter filtre magn. prim	1714568	1	1714568	1	1714568	1	1716858	1	1716858	1	1712346	1
31	Sechskantschraube spanner bolt écrou hexagon	2000001	4	2000001	4	2000001	4	2000001	4	2000001	4	2000001	4
32	Sechskantmutter nut écrou	2100004	4	2100004	4	2100004	4	2100004	4	2100004	4	2100004	4
33	Flachdichtung gasket joint	4-18109	1	4-18109	1	4-18109	1	4-18109	1	4-18109	1	4-18109	1
63	O-Ring (Viton) O-Ring O-Ring (Perbunan)	3030063 3031743	1	3030063 3031743	1	3030063 3031743	1	3030063 3031743	1	3030063 3031743	1	3030063 3031743	1
64	Elektrische Heizung electrical heating chauffage électrique	09228/05	1	09228/05	1	09228/05	1	09228/05	1	09228/05	1	09228/07	1
65	Thermostat thermostat thermostat	4600001	1	4600001	1	4600001	1	4600001	1	4600001	1	4600002	1
66	Entlüftung air escape désaération	11093 WN 103-1	1	11093 WN 103-1	1	11093 WN 103-1	1	11093 WN 103-1	1	11093 WN 103-1	1	11093 WN 103-1	1

29 FILTER, TYPE 6.61.

29.1 General

The fully automatic back-flushing filter is used to filter a variety of fluids. The filter element assemblies are cleaned automatically by compressed air assisted back-flushing without interrupting the filtration process. One clean chamber is always held in reserve.

This self-cleaning filter consists basically of lower housing with connection flange for filter outlet and connection flange for the removal of flushing fluid (sludge discharge), change-over system housing with the filter inlet, on which the filter chambers containing the candle elements and the automatic vent are set out (in the centre of the housing is the stop plug with refill bore), geared motor, air supply with non-return valve, shutt-off valve and pressure regulator., safety valve, differential pressure indicator $\Delta p1$, flushing valve with manual actuation, limit switch and electric control system in its own switch box, separate from the filter.

Filtration Phase

(see Drawing Z 32326 p. 1)

The medium to be filtered flows down into the change-over system housing and passes from there through the chamber inlet and the connected filter chambers to the candle elements.

The medium flows through the filter elements from the outside to the inside and the contamination in the medium is retained on the filter mesh of the candle elements. The cleaned fluid passes to the filter outlet.

In this position the air supply (by means of the solenoid valve) keeps the sludge discharge closed and compressed air is maintained in the air receiver ready for the next backflushing cycle.

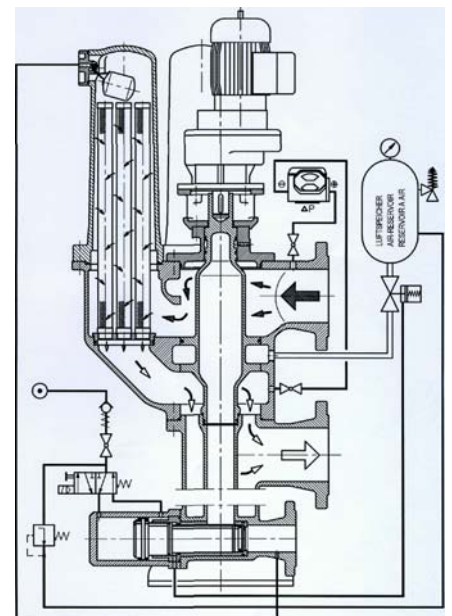

Drawing Z32326BL1

Back-Flushing Operation (See Drawing Z32326 p. 2)

The contamination retained on the candle elements produces an increasing pressure differential between the filter inlet and outlet. This difference in pressure is indicated optically on the differential pressure indicator when a set value is reached and an electrical contact triggers the back-flushing.

When the back-flushing cycle is initiated, the geared motor is switched on and the change-over plug rotates from the chamber held in reserve to the filter chamber to be cleaned. Connection of the reserve chamber, together with its clean candle elements, causes an immediate reduction in the pressure differential. When the stop plug reaches the filter chamber to be cleaned the rotation is stopped by means of a cam plate and a limit switch.

The solenoid valve (from the sludge discharge) is then switched electrically and air from the air supply passes to the rear side of the sludge discharge valve shaft. The sludge discharge valve opens and pressure is released from the chamber now shut off. (See Note!) This allows the compressed air in the upper region of the plug to immediately expand and thus creates additional space for the fluid displaced (by the air) in the backflushing cycle.

While the sludge discharge valve shaft is opening, the control system air reaches the attached flushing valve (once the pressure has been released on the filter chamber). The flushing valve opens and the compressed air from the air receiver dispatches the clean fluid present and pushes it in the counter current direction through the mesh of the screw-in candle elements.

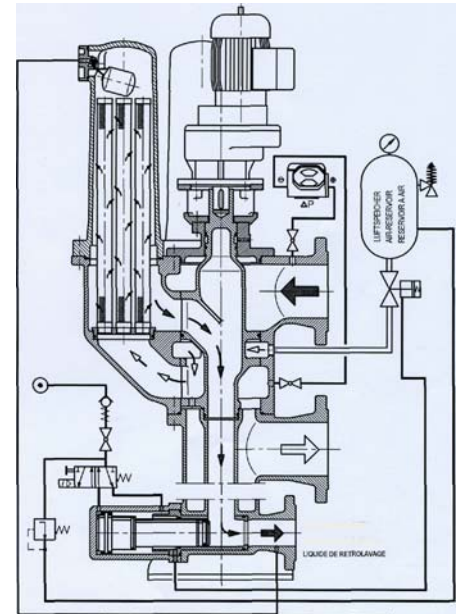

Drawing Z32326BL2

29.2 Start-up

The following requirements must be met for the commissioning of the filter:

1. Clean and dry compressed air for the control system at between 4 and 10 bar operating pressure, must be available at the open shut-off valve.
2. Switch on the electricity using the "Main Switch" on the switch box. The "Power" lamp respectively LED-operating display lights up. (Activation of the main switch initiates a back-flushing cycle.)
3. To check the electric control system a back-flushing cycle should now be performed by activating the "Manual" trip on the switch box.
4. Open the slide valve at the filter outlet. Slowly open the slide valve at the filter inlet (avoiding pipe hammer). A further back-flushing cycle is to be performed using the Manual trip on the switch box. Once the back-flushing operation is completed, the "Flushing" respectively the display "SP.1" lamp goes out. If these conditions are met, the filter is in the start position and is therefore ready for operation.

After completion of a back-flushing cycle, the next backflushing operation can only be initiated (manually or by means of the differential pressure indicator) after a time delay. This time delay corresponds to the time preset on the time relay "K1A" or the preselected time "PA.5" in the electronic control. It is needed to guarantee that the cleaned filter chamber is filled.

Possible time interval calculation for time-dependent back-flushing:

Let the filter run for 24 hours using the differential pressure and establish the number of back-flushing operations (flushing cycle counter or display).

Calculate the average flushing interval. Set the flushing interval (shortened by 30%) on the time relay or PA.2.

29.3 Manual operation of the automatic filter

Before operating the filter manually, you have to switch off the main switch on the control box, in the interests of safety (self-turning handle will cause violations).

Attach the crank handle supplied to the free end of the motor shaft. By rotating the motor (in either direction), the cam disc is rotated to the next change-over point (i.e. the next filter chamber). The cam and the limit switch must align precisely.

Back flushing is initiated directly by a manual actuation of the flushing valve (with a screw [60] driver). This manual actuation should last 12 seconds.

You have to wait 2 minutes before changing over to the next filter chamber, to give time to fill up the back-flushed filter chamber.

29.4 Control of automatic filter, type 6.61

Selecting parameter assignment mode of A14A1 (LOGO!) controller:

Note in parameter assignment mode, the LOGO! continues execution of the circuit program.

1. Press ▼ as many times as required to get date into the display
2. Press ESC to change from RUN to parameter assignment mode.

LOGO! changes to parameter assignment mode and opens the parameter assignment menu:

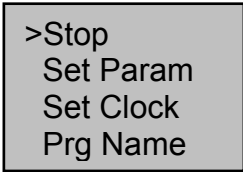

>Stop
Set Param
Set Clock
Prg Name

Moving from stop to Prg Name by pressing ▼ or ▲ buttons. Selection by pressing OK. Back by pressing ESC

Description of the four menu items of the parameter assignment menu:

1 Stop is selected to stop the circuit program.

After the program is stopped it can started from the opening menu. From where also the clock and the summer / winter time can be set by selecting Clock..

2 Set Param is selected to change the filter parameters.

Selection by pressing ▼ (cursor moves from Stop to Set Param) and then OK.

Moving from parameter to another by pressing ▼ and ▲ buttons.

Paramers are changed by pressing OK when the parameter to be changed is in display.

Back by pressing ESC.

3 Flush counter reset (example)

```
F CTR
On= 0
Off= 0
Cnt= 21
```

Flush counter value is in parameter Cnt

Press ► (or◀) as many times as required to move the cursor on 2.
Press ▼ 2 times to change 2 to 0. Press ► once to move the cursor
on 1. Press ▼ once to change 1 to 0. Press OK.

4 Sludge pump run time change (sludge pump is an option which may
not be installed).

```
SP RUN T
TH =02:00m
TL =00:00s
Ta =00:00
```

Sludge pump run time value is in parameter TH. 02 means minutes, 00
means seconds.

Press ► (or◀) as many times as required to move the cursor on 02:00.
Press ▼ or ▲ on numbers to change the run time. When the run time is
changed press OK.

29.4.1 Chamber fill up time change.

```
FILL UP
T =02:00m

Ta =02:00m
```

Chamber fill up time is in parameter T 02 means minutes, 00 means
seconds.

Press ► (or◀) as many times as required to move the cursor on 02:00.
Press ▼ or ▲ on numbers to change the fill up time. When the fill up
time is changed press OK.

29.4.2 Flush period change

```

F PERIOD
T =02:00h

Ta =00:00h
    
```

Flush period time value is in parameter T. 02 means hours, 00 means minutes.

Press ► (or◀) as many times as required to move the cursor on 02:00. Press ▼ or ▲ on numbers to change the flush period time. When the flush period is changed press OK.

29.4.3 Flush time change

```

F TIME
TH =05:00s
TL =05:00s
Ta =00:00
    
```

Flush time value is in parameter TH. 05 means seconds, 00 means fractional parts of seconds

Press ► (or◀) as many times as required to move the cursor on 05:00. Press ▼ or ▲ on numbers to change the flush time. When the flush time is changed press OK.

29.4.4 Parameter settings

Parameter	Factory setting	Setting limits which are not to go under or exceed
Sludge pump run time	2 minutes	from 2,0 to 5,0 minutes
Chamber fill up time	2 minutes	from 2,0 to 5,0 minutes
Flush period	2 hours	from 0,5 to 5 hours
Flush time	5 seconds	from 5,0 to 10,0 seconds

29.4.5 Set clock is selected to set time and date.

```
Set Clock
Su 00:00
YYYY-MM-DD
2003-01-01
```

Press ► (or ◀) as many times as required to move the cursor on parameter to be changed. Press ▼ or ▲ to change the parameter (e.g. day). After all parameters are correct press OK.

Prg Name is not used.

29.5 Maintenance

Even automatic filters require inspection and servicing at regular intervals. It is to be noted in particular that despite regular back-flushing the filter mesh can become clogged in the course of time, depending on the quality of the medium and the by-pass cleaning available. Contamination on the mesh can be removed by cleaning the candle element manually using an appropriate solvent (see section later). An increase in the clogging on the mesh can be inferred from the progressively shorter intervals between back-flushing cycles. The number of back-flushing cycles can be seen on the "Flushing cycle counter" respectively display on the switch box.

To maintain trouble-free operation, the following points are to be noted:

- a) All connections are to be regularly checked for leaks.
- b) Candle elements are to be dismantled and inspected initially after 500 flushing cycles, then after 5 000 and later every 10 000 flushing cycles. If, however, a sharp reduction in the intervals between back-flushing cycles should occur, inspection and cleaning should be carried out sooner. If sudden lengthening of the intervals between back-flushing cycles should occur, all candle elements must be inspected without fail for damage.



Before the cartridge elements are dismantled, the automatic filter must be completely drained by automatic back-flushing (i.e. all filter chambers). "Manual" activation on the control box. Care must be taken to ensure that the liquid level is below the cartridge element before the element is dismantled.

The candles are subjected to wear through reciprocal loading. It is therefore recommended that a complete candle filter element, the number of candle elements depending on the size of the filter, be kept in stock.

It is expedient to renew all seals when overhauling the filter.

Check the sludge discharge for leaks every 10 000 flushing cycles. No medium should run from the end of the sludge discharge line during the filtration phase (except during the flushing cycle).

You must close the compressed air supply valve (item 127), then starting a manual back flushing, before you are allowed to remove the manometer (item 72). This will ensure that the compressed air reservoir (item 13) is pressure released.

29.5.1 Servicing tools

The following special tools are supplied for servicing the filter:

Special key with SW 10 or 14 for dismantling the filter chamber.



Special key for unscrewing the candle elements from the candle holder.

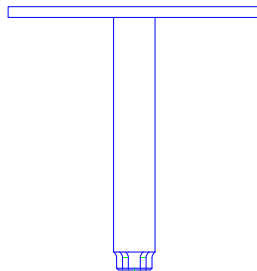

Key for opening the switch box and hand crank for operation during a power failure.

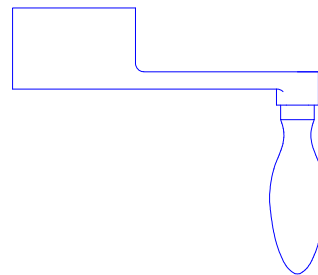
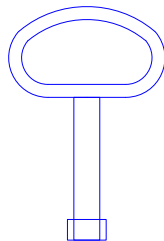

29.6 Candle element cleaning agent "BOLL CLEAN 2000"

The choice of cleaning medium depends on the type of the contamination. With fuels recipitation of paraffin and asphalt or with lubricating oils mixing of different types of oil can form solid encrustations on the mesh. Effective cleaning of fine meshes is achieved by soaking in "BOLL CLEAN 2000" followed by blasting with compressed air using a cleaning gun.

Product description:

BOLL CLEAN 2000 is a fluid cleaning and degreasing agent with a wide range of application. It can be used for practically all cleaning and degreasing purposes.

It cleans rapidly, thoroughly and extremely economically.

Use of it renders safety precautions superfluous. B

BOLL CLEAN 2000 is non-flammable, does not require special marking, does not have an irritating odour, is not caustic, is physiologically unobjectionable, is biologically degradable, is registered with the Federal Office for the Environment, Reg.-No. 04860019.

BOLL CLEAN 2000 can be under cooled or overheated during storage but remains fully usable when returned to normal temperature.

29.6.1 Mesh contaminated with heavy oil:

Elements contaminated with heavy oil must be soaked in a standard commercial solvent. After soaking, the elements are cleaned in the BOLL & KIRCH Type 5.04 Cleaning Device using BOLL CLEAN 2000 and high pressure pump.

Instructions for use:

Use of BOLL CLEAN 2000 is not restricted to a particular method of cleaning. Depending on the operating conditions, BOLL CLEAN 2000 can be used in a dip bath, in a spraying plant, in steam jetting or in manual application using a cloth, brush or sponge. It can be used warm or cold. BOLL CLEAN 2000 is miscible with water - even seawater. Concentration for mesh cleaning: 1:2,5 Temperature: up to a maximum of 60°C. The concentration depends on the type and thickness of the adhesive substance to be removed. When used in concentration below 1:30 rinsing is usually not required. No visible film remains on the surface.

29.6.2 Manual cleaning of the candle filter elements



Before the cartridge elements are dismantled, the automatic filter must be completely drained by automatic back-flushing (i.e. all filter chambers). "Manual" activation on the control box. Care must be taken to ensure that the liquid level is below the cartridge element before the element is dismantled.

Remove the whole filter element assembly. Then soak the filter element assembly, with the openings of the candle elements facing down, in a suitable tank filled with solvent. Detached contaminants can then sink downwards out of the candle.

The soaking time and the relevant solvents are:

- a) In cold BOLL CLEAN 2000 cleaner the maximum soaking time is 24 hours.
- b) In Filterclean (Vecom) the maximum soaking time is 12 hours.
- c) In Reiniger B85 (Vecom) the maximum soaking time is 12 hours.
- d) In gas oil the maximum soaking time is 48 hours.

After soaking, remove the whole filter element assembly from the tank and place it on a suitable stand (e.g. perforated sheet metal) with the candle element opening pointing down and allow the solvent to drain.

Now with the cleaning gun supplied blow compressed air through the candles from the inside to the outside.

After this procedure the complete filter element assembly should be immersed in fresh cleaner, with the candle element opening downwards, and rinsed through with an up and down motion.



The washing procedure described above should only be carried out in a separate tank using clean solvent. The solvent can then be used again for the next soaking procedure.

Allow the filter element assembly to drain again and dry it by blowing compressed air through it again from the inside to the outside. The manual cleaning procedure described here has produced adequate results (ca. 60% clean) in similar applications.

Almost 100 % cleaning is only possible manually by using the Type 5.04 High Pressure Cleaning Unit with BOLL CLEAN 2000.

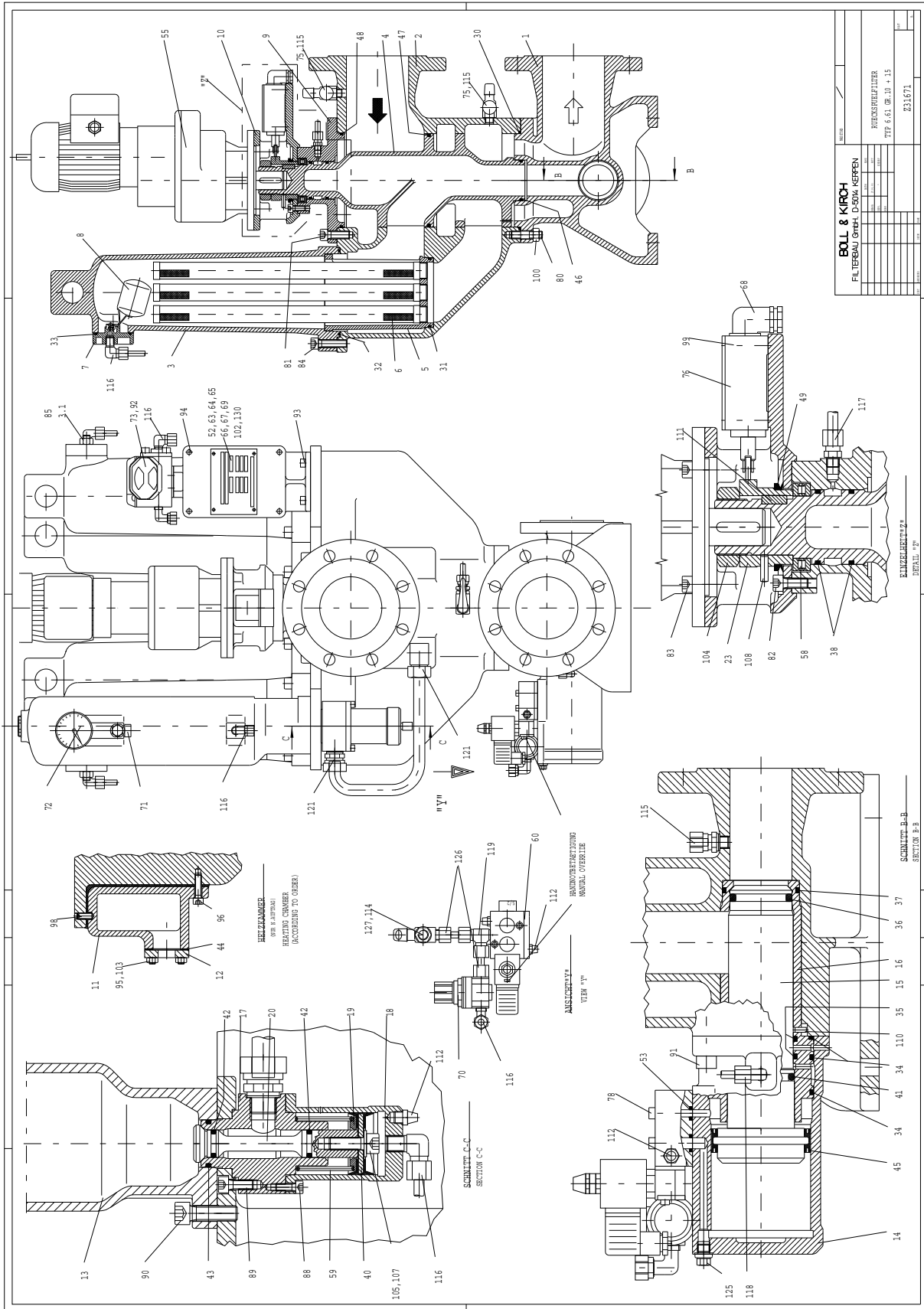

29.7 Spare parts

29.7.1 Type 6.61, GR.10 DN100 25/34/50 MICR

Document 0630319, 14329-03, drawing Z31671

pos	id	designation	qty
0001	5422697	housing lower part	1.000 st
0002	5423823	change over housing	1.000 st
0003	6537759	filter chamber	4.000 st
0003	2000004	stud bolt	8.000 st
0004	5421472	cock	1.000 st
0005	5007847	candle support	4.000 st
0006		filter c	32.000 st
0007	5906594	cover	4.000 st
0007	5218298	nozzle	4.000 st
0007	6712641	bow	4.000 st
0007	2000266	slotted chesse head	8.000 st
0008	2610023	float	4.000 st
0008	2611123	pin	4.000 st
0008	3530032	double nipple	4.000 st
0009	5229254	cover	1.000 st
0010	5427288	motor flange	1.000 st
0011	6530357	heating chamber	2.000 st
0012	5000011	counter flange	2.000 st
0013	6533516	air reservoir	1.000 st
0014	5229568	housing	1.000 st
0015	5000486	ram	1.000 st
0016	5005528	valve seat	1.000 st
0017	5005609	housing	1.000 st
0018	5006510	cover	1.000 st
0019	5007512	disc	1.000 st
0020	5006512	ram	1.000 st
0023	5120153	control disc	1.000 st
0030	3030729	gasket	1.000 st
0031	3030661	gasket	4.000 st
0032	3030761	gasket	4.000 st
0033	3132369	gasket	4.000 st
0034	3038188	o-ring	3.000 st
0035	3096894	gasket	2.000 st
0036	3096995	gasket	1.000 st
0037	3030063	gasket	1.000 st
0038	3030063	gasket	2.000 st
0040	2785451	piston	1.000 st
0041	3038126	gasket	1.000 st
0042	3098361	gasket	2.000 st
0043	3038361	gasket	1.000 st
0044	3380049	gasket	2.000 st
0045	3437135	gasket	1.000 st
0046	3030064	gasket	1.000 st
0047	3030762	gasket	1.000 st
0048	3030762	gasket	1.000 st
0049	3542193	v-ring	1.000 st
0052	3380199	gasket	1.000 st
0053	3040224	gasket	2.000 st
0055	4500100	5.5/6.6 upm gear motor	1.000 st

0058	2708948	cylindrical roller	1.000 st
0059	2307427	spring	1.000 st
0060	2656655	5/2 valve	1.000 st
0060	4206553	coil	1.000 st
0060	2614072	sound absorber	1.000 st
0063	5950196	connector box	1.000 st
0064	8450198	cover	1.000 st
0065	4105616	binder	15.000 st
0065	4105617	binder	6.000 st
0065	4100015	distance plate	3.000 st
0066	2000258	slotted cheese head	2.000 st
0067	4105805	assembly rail	1.000 st
0068	4102567	screwing	1.000 st
0068	4102568	adaptor	1.000 st
0069	4100101	cable gland	8.000 st
0069	4100103	cable screwing	1.000 st
0069	4870016	pg16 plug	1.000 st
0070	2650017	high pressure control	1.000 st
0071	2660005	safety valve	1.000 st
0072	2602689	manometer	1.000 st
0073	0550001	4.36.2, p=0.8, dda 09322 08	
		pressure different. contact indicator	1.000 st
0075	2560063	angle ball cock	2.000 st
0076	4200057	limit switch	1.000 st
0078	2002155	hexagon socket head	2.000 st
0080	2000239	stud	6.000 st
0081	2000155	socket head	6.000 st
0082	2000131	hexagon socket head	4.000 st
0083	2000132	socket head cap screw	4.000 st
0084	2000158	hexagon socket head	16.000 st
0085	2100006	hexagon nut	8.000 st
0088	2000122	hexagon socket head	4.000 st
0089	2000131	hexagon socket head	3.000 st
0090	2000156	hexagon socket head	2.000 st
0091	2000144	hexagon socket head	4.000 st
0092	2000122	hexagon socket head	2.000 st
0093	2000131	hexagon socket head	2.000 st
0094	2000261	slotted cheese head	2.000 st
0095	2000001	stud	8.000 st
0096	2000132	socket head cap screw	2.000 st
0098	2004354	set screw	2.000 st
0099	2000967	hexagon socket head	2.000 st
0100	2100011	hexagon nut	6.000 st
0102	2003587	screw	4.000 st
0103	2100004	hexagon nut	8.000 st
0104	5002790	nut	1.000 st
0105	2004715	bolt	1.000 st
0107	2200007	washer	1.000 st
0108	2308746	grooved pins with ro	1.000 st
0110	2001578	bolt	1.000 st
0111	2400109	parallel keys	1.000 st
0112	2614171	sound absorber	3.000 st
0114	2608775	non return valve	1.000 st
0115	2500024	screwing	3.000 st
0116	2500025	screwing	9.000 st
0117	2500028	screwing	1.000 st
0118	2500029	screwing	2.000 st
0119	2507461	screwing	1.000 st
0120	2500258	screwing	1.000 st
0121	2508115	screwing	2.000 st

0123	2505339	screwing	2.000 st
0124	2001772	hexagon head screw p	1.000 st
0124	3275525	gasket set	1.000 st
0125	2000186	hexagon head screw p	1.000 st
0125	3270001	seal	1.000 st
0126	2500083	nipple	2.000 st
0127	2560356	angle ball cock	1.000 st
0128	0602658	6.61 gr.10 pipe set z34749	1.000 st
0130	9401690	name plate wn26	1.000 st
0131	9407569	label "out"	1.000 st
0131	9400997	label "in"	1.000 st
0131	9407396	label "mud dra"	1.000 st
0131	9402898	label "air release"	1.000 st
0131	9405704	label "...2 hooks..."	2.000 st
0131	9403614	label "compressed air"	1.000 st
0131	9404642	label "delta p"	1.000 st
0140		electric	1.000 st
0150	6705030	key	1.000 st
0150	6705032	key for unscrewing t	1.000 st
0150	2300808	crank handle	1.000 st
0150	5700721	guide bolt	2.000 st
0180	3635420	gasket set	1.000 st

29.7.2 Type 6.61, GR.10 DN100 10 MICR

Document 0630319, 14329-04, drawing Z31671

pos	id	designation	qty
0001	5422697	housing lower part	1.000 st
0002	5423823	change over housing	1.000 st
0003	6537759	filter chamber	4.000 st
0003	2000004	stud bolt	8.000 st
0004	5421472	cock	1.000 st
0005	5007947	candle support	4.000 st
0006		sternkerze	8.000 st
0007	5906594	cover	4.000 st
0007	5218298	nozzle pos. 1	4.000 st
0007	6712641	bow	4.000 st
0007	2000266	slotted chesse head	8.000 st
0008	2610023	float	4.000 st
0008	2611123	pin	4.000 st
0008	3530032	double nipple	4.000 st
0009	5229254	cover	1.000 st
0010	5427288	motor flange	1.000 st
0011	6530357	heating chamber	2.000 st
0012	5000011	counter flange	2.000 st
0013	6533516	air reservoir	1.000 st
0014	5229568	housing	1.000 st
0015	5000486	ram	1.000 st
0016	5005528	valve seat	1.000 st
0017	5005609	housing	1.000 st
0018	5006510	cover	1.000 st
0019	5007512	disc	1.000 st
0020	5006512	ram	1.000 st
0023	5120153	control disc	1.000 st
0030	3030729	gasket	1.000 st
0031	3030661	gasket	4.000 st
0032	3030761	gasket	4.000 st

0033	3132369	gasket	4.000 st
0034	3038188	O-ring	3.000 st
0035	3096894	gasket	2.000 st
0036	3096995	gasket	1.000 st
0037	3030063	gasket	1.000 st
0038	3030063	gasket	2.000 st
0040	2785451	piston	1.000 st
0041	3038126	gasket	1.000 st
0042	3098361	gasket	2.000 st
0043	3038361	gasket	1.000 st
0044	3380049	gasket	2.000 st
0045	3437135	gasket	1.000 st
0046	3030064	gasket	1.000 st
0047	3030762	gasket	1.000 st
0048	3030762	gasket	1.000 st
0049	3542193	v-ring	1.000 st
0052	3380199	gasket	1.000 st
0053	3040224	gasket	2.000 st
0055	4500100	gear.motor 5.5/6.6upm	1.000 st
0058	2708948	cylindrical roller b	1.000 st
0059	2307427	spring	1.000 st
0060	2656655	5/2 valve	1.000 st
0060	4206553	coil	1.000 st
0060	2614072	sound absorber	1.000 st
0063	5950196	connector box	1.000 st
0064	8450198	cover	1.000 st
0065	4105616	binder	15.000 st
0065	4105617	binder	6.000 st
0065	4100015	distance plate	3.000 st
0066	2000258	slotted cheese head	2.000 st
0067	4105805	assembly rail	1.000 st
0068	4102567	screwing	1.000 st
0068	4102568	adaptor	1.000 st
0069	4100101	cable gland	8.000 st
0069	4100103	cable screwing	1.000 st
0069	4870016	plug pg16	1.000 st
0070	2650017	high pressure control	1.000 st
0071	2660005	safety valve	1.000 st
0072	2602689	manometer	1.000 st
0073	0550001	pressure different.contact indicator	
		4.36.2 p = 0.8 dda 09322 08	1.000 st
0075	2560063	angle ball cock	2.000 st
0076	4200057	limit switch	1.000 st
0078	2002155	hexagon socket head	2.000 st
0080	2000239	stud	6.000 st
0081	2000155	hexagon socket head	6.000 st
0082	2000131	hexagon socket head	4.000 st
0083	2000132	socket head cap screw	4.000 st
0084	2000158	hexagon socket head	16.000 st
0085	2100006	hexagon nut	8.000 st
0088	2000122	hexagon socket head	4.000 st
0089	2000131	hexagon socket head	3.000 st
0090	2000156	hexagon socket head	2.000 st
0091	2000144	hexagon socket head	4.000 st
0092	2000122	hexagon socket head	2.000 st
0093	2000131	hexagon socket head	2.000 st
0094	2000261	slotted cheese head	2.000 st
0095	2000001	stud	8.000 st
0096	2000132	socket head cap screw	2.000 st
0098	2004354	set screw	2.000 st

0099	2000967	hexagon socket head	2.000 st
0100	2100011	hexagon nut	6.000 st
0102	2003587	screw	4.000 st
0103	2100004	hexagon nut	8.000 st
0104	5002790	nut	1.000 st
0105	2004715	bolt	1.000 st
0107	2200007	washer	1.000 st
0108	2308746	grooved pins with ro	1.000 st
0110	2001578	bolt	1.000 st
0111	2400109	parallel keys	1.000 st
0112	2614171	sound absorber	3.000 st
0114	2608775	non return valve	1.000 st
0115	2500024	screwing	3.000 st
0116	2500025	screwing	9.000 st
0117	2500028	screwing	1.000 st
0118	2500029	screwing	2.000 st
0119	2507461	screwing	1.000 st
0120	2500258	screwing	1.000 st
0121	2508115	screwing	2.000 st
0123	2505339	screwing	2.000 st
0124	2001772	hexagon head screw p	1.000 st
0124	3275525	gasket set	1.000 st
0125	2000186	hexagon head screw p	1.000 st
0125	3270001	seal	1.000 st
0126	2500083	nipple	2.000 st
0127	2560356	angle ball cock	1.000 st
0128	0602658	pipe set 6.61 gr.10 z34749	1.000 st
0130	9401690	name plate	1.000 st
0131	9407569	label "out"	1.000 st
0131	9400997	label "in"	1.000 st
0131	9407396	label "mud dra"	1.000 st
0131	9402898	label air release	1.000 st
0131	9405704	label ".2 hooks".	2.000 st
0131	9403614	label "compressed air"	1.000 st
0131	9404642	label " delta p	1.000 st
0140		electric	1.000 st
0150	6705030	key	1.000 st
0150	6705032	key for unscrewing t	1.000 st
0150	2300808	crank handle	1.000 st
0150	5700721	guide bolt	2.000 st
0180	3635420	gasket set	1.000 st

29.7.3 Type 6.61, GR.15 DN150 10 MICR

Document 0630126, 14327-04, drawing Z31671

pos	id	designation	qty
0001	6534520	housing lower part	1.000 st
0002	6534555	change over housing	1.000 st
0003	6537759	filter chamber	7.000 st
0003	2000004	stud bolt	14.000 st
0004	5423986	cock	1.000 st
0005	5007947	candle support	7.000 st
0006		sternkerze (filtra	14.000 st
0007	5906594	cover	7.000 st
0007	5218298	nozzle pos. 1	7.000 st
0007	6712641	bow	7.000 st
0007	2000266	slotted chesse head	14.000 st

0008	2610023	float	7.000 st
0008	2611123	pin	7.000 st
0008	3530032	double nipple	.000 st
0009	6437001	cover	1.000 st
0010	5427288	motor flange	1.000 st
0011	6530357	heating chamber	4.000 st
0012	5000011	counter flange	4.000 st
0013	6533516	air reservoir 1	.000 st
0014	5229568	housing	1.000 st
0015	5000486	ram	1.000 st
0016	5005528	valve seat	1.000 st
0017	5005609	housing	1.000 st
0018	5006510	cover	1.000 st
0019	5007512	disc	1.000 st
0020	5006512	ram	1.000 st
0023	5134295	control disc	1.000 st
0030	3030500	gasket	1.000 st
0031	3030661	gasket	7.000 st
0032	3030761	gasket	4.000 st
0033	3132369	gasket	7.000 st
0034	3038188		3.000 st
0035	3096894	gasket	2.000 st
0036	3096995	gasket	1.000 st
0037	3030063	gasket	1.000 st
0038	3030063	gasket	2.000 st
0040	2785451	piston	1.000 st
0041	3038126	gasket	1.000 st
0042	3098361	gasket	2.000 st
0043	3038361	gasket	1.000 st
0044	3380049	gasket	4.000 st
0045	3437135	gasket	1.000 st
0046	3030064	gasket	1.000 st
0047	3032130	gasket	1.000 st
0048	3030500	gasket	1.000 st
0049	3542193		1.000 st
0052	3380199	gasket	1.000 st
0053	3040224	gasket	2.000 st
0055	4500100	gear.motor 5.5/6.6upm	1.000 st
0058	2708948	cylindrical roller b	1.000 st
0059	2307427	spring	1.000 st
0060	2656655	5/2 valve	1.000 st
0060	4206553	coil	1.000 st
0060	4105912	receptacle	1.000 st
0060	2614072	sound absorber	1.000 st
0063	5950196	connector box	1.000 st
0064	8450198	cover	1.000 st
0065	4105616	binder	15.000 st
0065	4105617	binder	6.000 st
0065	4100015	distance plate	3.000 st
0066	2000258	slotted cheese head	2.000 st
0067	4105805	assembly rail	1.000 st
0068	4102567	screwing	1.000 st
0068	4102568	adaptor	1.000 st
0069	4100101	cable gland	8.000 st
0069	4100103	cable screwing	1.000 st
0069	4870016	plug pg16	1.000 st
0070	2650017	high pressure control	1.000 st
0071	2660005	safety valve	1.000 st
0072	2602689	manometer	1.000 st

0073	0550001	pressure different.contact indicator 4.36.2 p = 0.8 dda 09322 08	1.000 st
0075	2560063	angle ball cock	2.000 st
0076	4200057	limit switch	1.000 st
0078	2002155	hexagon socket head	2.000 st
0080	2003612	stud	8.000 st
0081	2000156	hexagon socket head	8.000 st
0082	2000131	hexagon socket head	4.000 st
0083	2000132	socket head cap screw	4.000 st
0084	2000158	hexagon socket head	28.000 st
0085	2100006	hexagon nut	14.000 st
0088	2000122	hexagon socket head	4.000 st
0089	2000131	hexagon socket head	3.000 st
0090	2000156	hexagon socket head	2.000 st
0091	2000144	hexagon socket head	4.000 st
0092	2000122	hexagon socket head	2.000 st
0093	2000131	hexagon socket head	2.000 st
0094	2000261	slotted cheese head	2.000 st
0095	2000001	stud	16.000 st
0096	2000132	socket head cap screw	4.000 st
0098	2004354	set screw	4.000 st
0099	2000967	hexagon socket head	2.000 st
0100	2100012	hexagon nut	8.000 st
0102	2003587	screw	4.000 st
0103	2100004	hexagon nut	16.000 st
0104	5002790	nut	1.000 st
0105	2004715	bolt	1.000 st
0107	2200007	washer	1.000 st
0108	2308746	grooved pins with ro	1.000 st
0110	2001578	bolt	1.000 st
0111	2400109	parallel keys	1.000 st
0112	2614171	sound absorber	3.000 st
0113	2500258	screwing	1.000 st
0114	2608775	non return valve	1.000 st
0115	2500024	screwing	4.000 st
0116	2500025	screwing	11.000 st
0117	2500028	screwing	1.000 st
0118	2500029	screwing	2.000 st
0119	2507461	screwing	1.000 st
0120	2503347	screwing	1.000 st
0121	2508115	screwing	1.000 st
0122	2505339	screwing	4.000 st
0123	2507808	screwing	1.000 st
0124	2001772	hexagon head screw p	1.000 st
0124	3275525	gasket set	1.000 st
0125	2000186	hexagon head screw p	1.000 st
0125	3270001	seal	1.000 st
0126	2500083	nipple	2.000 st
0127	2560356	angle ball cock	1.000 st
0128	0603914	pipe set 6.61 gr.15 z34988	1.000 st
0130	9401690	name plate	1.000 st
0131	9407569	label " out "	1.000 st
0131	9400997	label "in"	1.000 st
0131	9407396	label "mud dra"	1.000 st
0131	9402898	label "air release"	1.000 st
0131	9405704	label "2 hooks".	2.000 st
0131	9403614	label "compressed air"	1.000 st
0131	9404642	label " delta p"	1.000 st
0140		electric	1.000 st
0150	6705030	key	1.000 st

0150	6705032	key for unscrewing t	1.000 st
0150	2300808	crank handle	1.000 st
0150	5700721	guide bolt	2.000 st
0180	3635421	gasket set	1.000 st
0200	2802418	flange	1.000 st
0200	2000510	hexagon screw	4.000 st
0200	2100007	hexagon nut	4.000 st
0200	3380067	gasket	1.000 st

29.7.4 Type 6.61, GR.15 DN150 25/34/50 MICR

Document 0630124, 14327-03, drawing Z31671

pos	id	designation	qty
0001	6534520	housing lower part	1.000 st
0002	6534555	change over housing	1.000 st
0003	6537759	filter chamber	7.000 st
0003	2000004	stud bolt	14.000 st
0004	5423986	cock	1.000 st
0005	5007847	candle support	7.000 st
0006		filter c	56.000 st
0007	5906594	cover	7.000 st
0007	5218298	nozzle pos. 1	7.000 st
0007	6712641	bow	7.000 st
0007	2000266	slotted chesse head	14.000 st
0008	2610023	float	7.000 st
0008	2611123	pin	7.000 st
0008	3530032	double nipple	7.000 st
0009	6437001	cover	1.000 st
0010	5427288	motor flange	1.000 st
0011	6530357	heating chamber	4.000 st
0012	5000011	counter flange	4.000 st
0013	6533516	air reservoir	1.000 st
0014	5229568	housing	1.000 st
0015	5000486	ram	1.000 st
0016	5005528	valve seat	1.000 st
0017	5005609	housing	1.000 st
0018	5006510	cover	1.000 st
0019	5007512	disc	1.000 st
0020	5006512	ram	1.000 st
0023	5134295	control disc	1.000 st
0030	3030500	gasket	1.000 st
0031	3030661	gasket	7.000 st
0032	3030761	gasket	7.000 st
0033	3132369	gasket	7.000 st
0034	3038188	o-ring	3.000 st
0035	3096894	gasket	2.000 st
0036	3096995	gasket	1.000 st
0037	3030063	gasket	1.000 st
0038	3030063	gasket	2.000 st
0040	2785451	piston	1.000 st
0041	3038126	gasket	1.000 st
0042	3098361	gasket	2.000 st
0043	3038361	gasket	1.000 st
0044	3380049	gasket	4.000 st
0045	3437135	gasket	1.000 st
0046	3030064	gasket	1.000 st
0047	3032130	gasket	1.000 st

0048	3030500	gasket	1.000 st
0049	3542193	v-ring	1.000 st
0052	3380199	gasket	1.000 st
0053	3040224	gasket	2.000 st
0055	4500100	gear motor 5.5/6.6upm	1.000 st
0058	2708948	cylindrical roller b	1.000 st
0059	2307427	spring	1.000 st
0060	2656655	5/2 valve	1.000 st
0060	4206553	coil	1.000 st
0060	4105912	receptacle	1.000 st
0060	2614072	sound absorber	1.000 st
0063	5950196	connector box	1.000 st
0064	8450198	cover	1.000 st
0065	4105616	binder	15.000 st
0065	4105617	binder	6.000 st
0065	4100015	distance plate	3.000 st
0066	2000258	slotted cheese head	2.000 st
0067	4105805	assembly rail	1.000 st
0068	4102567	screwing	1.000 st
0068	4102568	adaptor	1.000 st
0069	4100101	cable gland	8.000 st
0069	4100103	cable screwing	1.000 st
0069	4870016	plug pg16	1.000 st
0070	2650017	high pressure control	1.000 st
0071	2660005	safety valve	1.000 st
0072	2602689	manometer	1.000 st
0073	0550001	pressure different.contact indicator 4.36.2 p = 0.8 dda 09322 08	1.000 st
0075	2560063	angle ball cock	2.000 st
0076	4200057	limit switch	1.000 st
0078	2002155	hexagon socket head	2.000 st
0080	2003612	stud	8.000 st
0081	2000156	hexagon socket head	8.000 st
0082	2000131	hexagon socket head	4.000 st
0083	2000132	socket head cap screw	4.000 st
0084	2000158	hexagon socket head	28.000 st
0085	2100006	hexagon nut	14.000 st
0088	2000122	hexagon socket head	4.000 st
0089	2000131	hexagon socket head	3.000 st
0090	2000156	hexagon socket head	2.000 st
0091	2000144	hexagon socket head	4.000 st
0092	2000122	hexagon socket head	2.000 st
0093	2000131	hexagon socket head	2.000 st
0094	2000261	slotted cheese head	2.000 st
0095	2000001	stud	16.000 st
0096	2000132	socket head cap screw	4.000 st
0098	2004354	set screw	4.000 st
0099	2000967	hexagon socket head	2.000 st
0100	2100012	hexagon nut	8.000 st
0102	2003587	screw	4.000 st
0103	2100004	hexagon nut	16.000 st
0104	5002790	nut	1.000 st
0105	2004715	bolt	1.000 st
0107	2200007	washer	1.000 st
0108	2308746	grooved pins with ro	1.000 st
0110	2001578	bolt	1.000 st
0111	2400109	parallel keys	1.000 st
0112	2614171	sound absorber	3.000 st
0113	2500258	screwing	1.000 st
0114	2608775	non return valve	1.000 st

0115	2500024	screwing	4.000 st
0116	2500025	screwing	11.000 st
0117	2500028	screwing	1.000 st
0118	2500029	screwing	2.000 st
0119	2507461	screwing	1.000 st
0120	2503347	screwing	1.000 st
0121	2508115	screwing	1.000 st
0122	2505339	screwing	4.000 st
0123	2507808	screwing	1.000 st
0124	2001772	hexagon head screw p	1.000 st
0124	3275525	gasket set	1.000 st
0125	2000186	hexagon head screw p	1.000 st
0125	3270001	seal	1.000 st
0126	2500083	nipple	2.000 st
0127	2560356	angle ball cock	1.000 st
0128	0603914	pipe set 6.61 gr.15 z34988	1.000 st
0130	9401690	name plate	1.000 st
0131	9407569	label " out "	1.000 st
0131	9400997	label " in "	1.000 st
0131	9407396	label " mud dra"	1.000 st
0131	9402898	label "air release"	1.000 st
0131	9405704	label "...2 hooks"	2.000 st
0131	9403614	label "compressed air"	1.000 st
0131	9404642	label " delta p"	1.000 st
0140		electric	1.000 st
0150	6705030	key	1.000 st
0150	6705032	key for unscrewing t	1.000 st
0150	2300808	crank handle	1.000 st
0150	5700721	guide bolt	2.000 st
0180	3635421	gasket set	1.000 st
0200	2802418	flange	1.000 st
0200	2000510	hexagon screw	4.000 st
0200	2100007	hexagon nut	4.000 st
0200	3380067	gasket	1.000 st

TYP4.36.2
06.01.9

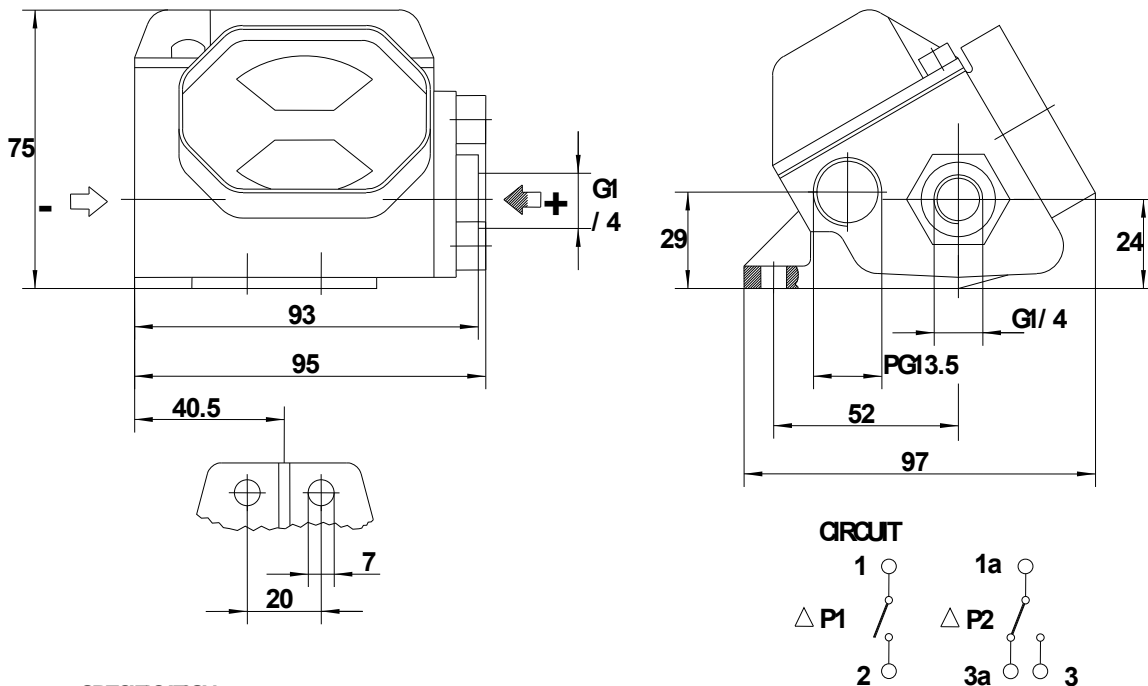

SPECIFICATION
PROTECTION CLASS: IP

ELECTR DATA: SWITCHING VOLTAGE V= MAX= 250 ~
 FREQUENCY HZ MAX= 0- 60
 SWITCHING CURRENT A MAX= 1
 MAKING AND/ OR BREAKING
 W VA MAX= 60/ 60

MATERIAL : GD -
RATING : MAX PRESSURE 100
 MAX TEMPERATURE

RANGES OF PRESSURE DIFFERENTIAL : DELTA P = 0 - 0.5
 0 - 0.8 BAR TO BE
 0 - 1.2 BAR WHEN
 0
 0 - 3.0 } 2.0 BAR

DESCRIPTION

THE PURPOSE OF THIS DEVICE IS THE MEASUREMENT, AND VISUAL OF THE DIFFERENCE IN PRESSURE BETWEEN TWO POINTS, AND THE MOVEMENT OF AN ELECTRICAL CONTACT WHEN THE PRESSURE DIFFERENTIAL IS A SPECIFIED

METHOD OF

A PLUNGER SEALED BY A DIAPHRAGM DIVIDES THE SPACE UNDER INTO TWO CHAMBERS. A PRE- LOADED SPRING CAUSES THE PLUNGER TO UP ITS ZERO POSITION WHEN THE PRESSURE DIFFERENCE DELTA P IS AS THE PRESSURE DIFFERENCE INCREASES (DELTA P > 0), THE PLUNGER IS FORCED TO MOVE AGAINST THE SPRING. AT THE SAME TIME, AN INDICATOR DISC IS MOVED MAGNETICALLY, AND THEREFORE VIRTUALLY WITHOUT FRICTION, AND THE TWO REED CONTACTS ARE

THE RED SEGMENT OF THE INDICATOR DISC IS VISIBLE OVER A RANGE EQUAL TO 20- 100% DELTA P. THE FIRST REED CONTACT IS AT 75% DELTA P, AND THE SECOND AT 100%

DIFFERENTIAL PRESSURE CONTACT

3

B

A

GEKLEBT
CEMENTED
COLLE

BEI BESTELLUNG ANGEBEN
TO BE MENTIONED IN CASE OF ORDER
A MENTIONNER LORS DE LA COMMANDE

AUFTR. NR. :
ORDER NO. :
NO DE COMMANDE

TYP 4.36.2

11

10

7

3

POS. NR.

11

7

10

A - B

11	ROLLMEMBRAN	DIAPHRAGM	DIAPHRAGME
10	FEDER	SPRING	RESSORT
7	KOLBEN	PISTON	PISTON
3	DICHTUNG	GASKET	JOINT
	BEZEICHNUNG	DESIGNATION	DESIGNATION
ERSATZTEILZEICHNUNG ZUM TYP 4.36.2 UND 4.46.2 PLAN DES PIÈCES DE RECHANGE			
SPART PARTS DRAWING			
11.02.94	BOLL & KIRCH FILTERBAU GMBH SIEMENSSTRASSE, 50170 KERPEN-SINDORF		Z21434

30 PRESSURE VESSELS

To ensure faultless operation, check regularly the operation of the pressure relief valve and any other safety devices visually. If a safety device is found damaged it must be replaced. The internal and external condition of the vessel is inspected.

NOTE: The manufacturer of the vessel shall be contacted if it is established that the vessel has been deformed, damaged, corroded, or if its surface coating is torn. Repair measures must be agreed with the manufacturer of the pressure equipment.

NOTE: The decisions of the local pressure equipment authorities in the target country apply for any possible repair and modification work.



1. To avoid damaging the pressure vessel, do not exceed the maximum allowed operating pressure which is shown on the vessel's nameplate. Use the relief valve.
2. Do not exceed the maximum allowed operating temperature which is shown on the pressure vessel's nameplate. As the temperature rises, the pressure rises too. Use the relief valve.
3. Do not touch the surface of the vessel when its internal temperature exceeds 60 °C. The vessel surface is burning hot. Be careful with the hot contents.

A commissioning inspection, i.e. the first periodic service, is performed for pressure vessels which are to be registered. The first periodic inspection is performed by the notified body and the owner or the holder is obliged to apply to the notified body for the performance of the inspection.

31 HOW TO ORDER SPARE PARTS

Identification of needed part

When ordering spare parts, please mention the following:

- 1 Serial number of the unit
(welded on the bottom beam of the unit frame)

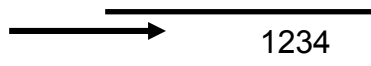

- 2 Part number from the part list

PART NO	
E17011	
E17033	
E17070	

- 3 Serial number of the part to be replaced
(mentioned in the rating plate of the part)



Ordering address:

Auramarine Ltd., After Sales Dept., P.O. Box 849, FIN-20101 TURKU
Fax +358 204 86 5031
Tel +358 204 86 5030

In case of guarantee part(s), please return the damaged part(s) to the above mentioned address.