

Speed indicator and Monitoring instrument AK 161...

**MESS- UND
STEUERUNGSTECHNIK
NORD GMBH**



- Frequency input
- Programable contact output
- 4-digits display, 14mm digits
- Type approval by Germanischer Lloyd

Speed monitoring device AK161... has been designed to Monitor speed on diesel engines. The isolated frequency input allows reliable speed sensing regardless of ground loops or power supply grounding. An internal temperature sensor monitors ambient temperature and based on this reading the instrument is capable to reduce display brightness on request. This makes it very useful in case of high ambient temperatures (engine room).



Technical Data:

Input:	Frequency input, sinusoidal or P-switching, H-signal approx. 3V, Range 2Hz – 20KHz	Contact K2:	May be used to enable / disable the engine monitoring system and the starter motor. Operation of K2 is explained on page 2 of this document.
Display:	4 digits, red LED display, height 14mm and two additional LED showing status of the contact outputs.	Accuracy accuracy (speed):	Speed sensing and indication is at least 0,5%, of full range input +1digit
Scaling:	By entering the desired reading and the frequency that is corresponding to this reading or by programing the device while running it. See programing manual for more detailed instructions.	Accuracy (temp.):	Temperature range is -10°C to +80°C accuracy is ±3°C. Out of range status will be indicated by displaying „Err“
Contact Output, generally:	2 contact outputs, normal open, programable trip point and hysteresis, breaking capacity 5A / 250V AC / 30V DC. For programing details see programing manual.	Program data	Input frequency, reading that is corresponding to this input, trip point and releasing point for K1, speed that enables and disables the starter motor, minimum engine speed.
Contact K1:	Overspeed monitoring. The relay will be engaged once the speed exceeds the limit entered under „trip point K1“ (see programing instructions) and it will be disengaged once the speed goes lower than entered under „release point K1“.	Housing:	Plastic housing according to DIN 43700 with red transparent reading window, dimensions 96x48x62,5 mm (width x height x depth). Required cutout: 92 ^{+0,8} x 45 ^{+0,6} mm
Switching delay:	The time between the first occurrence of overspeed and the moment the contact of K1 is closing will be maximum 0,8s but not less than 4 times the period of frequency input signal, whichever is greater.	Enclosure:	Housing IP 40 (DIN 40050), Terminals IP 20, upon request an additional gasket is available to achieve IP 42
Overspeed test:	Overspeed and subsequent safety chain may be tested by external jumper.	Terminals:	Spring loaded terminals suitable for cables up to max. 2,5mm ²
		Power:	24 V DC +/-20%, consumption approx. 6W
		Temp:	Operating temperature 0-60°C
		Weight:	approx. 200g
		Order code:	AK 161/24-i-2

Main dimensions and connectors AK 161/24-i-2

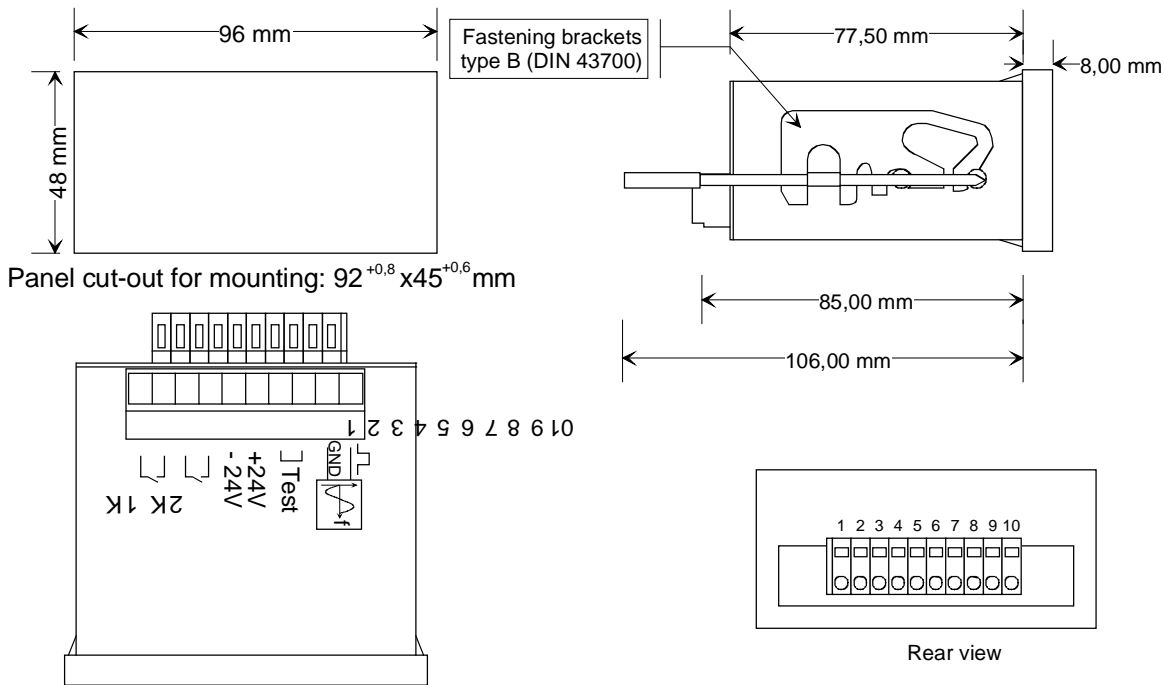

Behaviour of K2 is adapted for enabling / disabling engine monitoring system and engine starter motor. Once the speed exceeds enabling limit (E), contact output K2 will be closed, enabling engine monitoring and disabling engine starter motor. If the speed drops lower than E, K2 will be disengaged, reenabling the starter motor. Once the minimum engine speed (M) has been touched the enabling / disabling speed will be risen to (A). Now the starter motor will be enabled as soon as the speed drops lower than (A). This ensures that the starter motor will be reenabled during previous engine stop.

